

Class [redacted] Book [redacted]

17

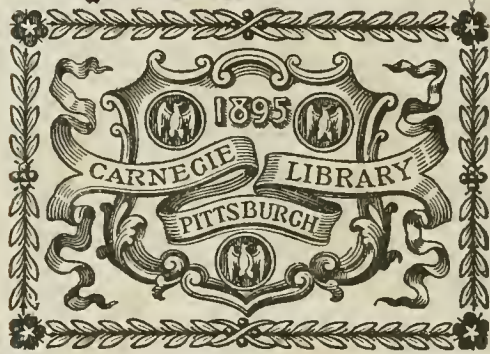









L Railway and Locomotive Engineering

A Practical Journal of Railway Motive Power and Rolling Stock

136 Liberty Street, New York.

INDEX FOR VOLUME XVII, 1904.

Illustrated articles are marked with an asterisk, thus *.

A

Accident, *Loading of Locomotive by, 23.
The Irrepressible Railway, 426.
Accidents, Caused by the Chance Taker, 71.
Comparison of, 213.
Interstate Commerce Commission Bulletin of, 421.
Mileage Basis for Comparing, 209.
To make Railroad, Impossible, 443.
Air Brake Subjects:
Air Brake Association, Experts of, 262.
Air Brakes; Best Advantage of, 453.
Air Brake Association, 217.
Air Brake Book That is a Jewel, An, 126.
Air Cylinder Oil Cup, Automatic, 320.
Air Pumps, Arrangement of, 87.
Air Pump Lifter, An, 459.
American Brakes in Russia, 87.
Automatic Slack Adjuster, Service Test of, 606.
Automatic Slack Adjuster, Hints on Care of, 169.
Braking Power, Higher, 413.
Brake Retardation at Different Periods of the Stop, 88, 89.
Brake Shoes, Flanged and Plain, 460.
Collision, Energy Line, The, 123.
Compensating Valve for High Speed Brakes, New York Air Brake Company's, 124, 126.
Compensating Valve, The New York, 218.
Convention, Air Brake Association, 170, 267, 268, 293, 294, 295, 317, 318, 319.
Coupler, Automatic Air & Steam, 457.
Dragging, Hoses, Evils of, 123.
Duplex Air Pump, Marsh's, 90.
Duplex Brake Valve, The New York, 319.
Duplex Straight Air and Automatic Brake, 269.
Fall of Pressure and Stoppages in Train Pipes, The Effect of, 415.
Forward Truck Brake a Hindrance to Engine Curving, 88.
Foundation Brake Gear, Necessary Changes, in, 457.
Fraudulent Practice in Air Brakes, 87.
Gauge Tester, Adjustable Target, 505.
General Manager, Thinks Hard—Very Hard, The, 517, 518, 619, 527.
Hand Brake, Necessity for on Large Capacity Cars, 414, 415.
Hose, Pulling Apart, 458.
Leakage Brake Cylinder, 366, 367.
Leaky Slide Valve, Probably, 367.
Metal Brake Beams, Better, Needed, 458.
Metal Brake Beams, Faulty, 417.
Oil Cup Cap, Improved, 505.
Packing Rings, Don't Hang Up, 461.
Patents, Air Brake, 236.
Questions and Answers on the Air Brake, 90, 91, 92, 127, 173, 219, 220, 271, 321, 369, 416, 417, 461, 506.
Rack Table, Air Pump Repairman's, 460.
Recharging and Retaining Device, 170.
Reminiscence of an Old Timer, 126.
Retaining Device for Locomotives, Air Brake, 172.
Sand Blower and Brake Attachment, 320, 321.
Stenciling Brakes, Better Method of, 218.
Stenciling, 457, 458.
Straight Air Service, Air Brakes in, 41.
Tests, Air Brake, How Made, 35, 41.
Train Line Pipe Coupling, Automatic, 460.
Train Pipe Leakage and Speed of Air Pump, 505.
Triple Piston Ring Grinding Machine, 217.
Triple Valves for Tenders, Plain vs. Quick Action, 413.
Triple Valve Testing Machine, 366.
Unbraked Weight per Axle, vs. 90 per cent. Plan for Passenger Equipment Cars, 270, 271.
Valve Handle Returning Device, Automatic, 365.
Water Jacketed Air Cylinder of Air Pump, 88.

Allis-Chalmers Company, Appliances Furnished by, 471.
American Locomotive Company, Report of, 483.
Appliances, Patented, Discussed at Railroad Clubs, 81.
Apprentice, Railroad Shop, 212.
Helping Grand Trunk, 536.
Armstrong Bros. Tool Exhibited at St. Louis, 473.
Automobiles, Gordon Bennett Race, 350.
*Mt. Washington Hill Climb, 379.
*Racing of, in Florida, 121.
Axle Box, *The McCord, 147.

B

Baldwin Locomotive Works, Output of, in 1903, 115.
Prizes for, 545.
Ball Joint, *Harter's, 22.
Bells and Whistles, Noises from, 118.
Bettendorf Truck, 381.
Boiler Explosions, Cause of, 116.
Record of, 404.
Boiler Head, First Stand, 67, *157.
Boiler, Locomotive, for Swedish Railways, 13.
Maintenance of Locomotive, 609.
No Danger of Feeding While Hot, 103.
Prevention of, Leaks, 56.
Boilers, Designing of Locomotive, by Roger Atkinson, 161, 200, 274.
Investigating Locomotive, 358.
Test of Locomotive, 443.
Boiler Tubes, *Relative Value of Steel and Iron, 469.
Book Notices, Alternating Currents, by George T. Hanchett, 167.
Arithmetic of Electricity, by T. O'Connor Sloane, 72.
Boiler Construction, by Frank B. Kleinhaus, 409.
Boiler Making by Sexton, 18.
Electric Toy Making, by T. O'Connor Sloane, 72.
Electric Traction, by J. H. Rider, 119.
Facts About Peat, by T. A. Leavitt, 167.
Free Hand Lettering, by V. T. Wilson, 72.
Locomotive Operations, by G. R. Henderson, 549.
Machine Design, by Cathcart, 72.
Mechanical Appliances, by G. D. Hiscox, 549.
New York Air Brake Catechism, by Robt. H. Blackall, 284.
Self Propelled Vehicles, by Jas. E. Homans, 499.
Spangenberg's Steam and Electric Engineering, 409.
Steel Square Pocketbook by D. L. Studdart, 409.
Testing of Electro Magnetic Machinery, by B. D. Swenson, 119.
The Isthmian Canal, by Wm. A. Barr, 119.
The Metric Fallacy, by F. A. Halsey, 119.
Twentieth Century Locomotives, by Angus Sinclair Company, 284.
Borneo, *Scenes in North, 249.
Bridge *Laurier, 560.
Moving Delaware, Lackawanna, 42.
Bridges, *Signals Protecting, 491.
Brotherhood Meeting of Locomotive Engineers, 418.
To Make Meetings of, More Interesting, 497.
Brotherhoods, Railway, Victory for, 451.

C

Carborundum at St. Louis, 311.
Car, a Collision Baggage, 537.
*Box With Steel Underframe, 79.
*Buffet on C. G. W., 138.
*Climax Vestibule Diaphragm, 335.
*Erie Passenger, 412.
Holland Sleeping, on a Street Railway, 439.
*Instruction, on the New York "L," 26.
*Lawson Dump, 185.
*Long Island Hospital, 562.

Master Car Builders, brass, 308.
*Modern Box, 248.
*Old Style Rockers, 248.
Interchange Manual, 276.
Interchangeable, Wheels, 401.
*Paint Shop Scaffolding, 540.
*Parlor, on B. & A., 531.
*Pressed Steel Tank, 563.
*Underground Instruction, 447.
*Vanderbilt Steel Flat, 276.
*Vanderbilt Steel Hopper, 57.
*Vestibule Stock, 24.
Cars, Bad Order, 198.
Built in 1903, 99.
Dimensions of Box, 398.
Motor, for Surface Railways, 118.
Number Handled in 1903, 103.
*Pere Marquette Lunch, 482.
*Pressed Steel, 326.
Prices for Repair of Steel, 412.
Steel Construction, 407.
Texas Law on Supply of, 23.
Tricks in Building, 310.
Ventilation of Passenger, 540.
Cast Iron, Process for Hardening, 374.
Chart, Educational Locomotive, 345, 362.
Tractive Power, 499.
Clearing House, A Railroad, 156.
Clock, *Ten Hour, 422.
Collisions, as a Public Spectacle, 358.
To Prevent Train, 498.
Color, What is? 108.
Combustion, Air Required for, 464.
Spontaneous, 223.
Combustion Chambers, Use of, 70.
Commission, Canada's Railway, 499.
Compound Locomotive, Care and Handling of, 11.
Four Cylinder Balanced, 444.
Hard at Work, 395.
Locating Defects in Schenectady's Cross, 110.
*On a Heavy Pull, 149.
*On Swedish State Railways, 12.
Prof. Goss on, 750.
*Richmond, 561.
Tests of, 256.
To Locate Blows on Tandem, 281.
Wants Fair Play for, 23.
*Well Kept at Work, 459.
Convention, Brotherhood of Locomotive Engineers, 288.
Firemen's, 456.
Traveling Engineers' 476, 485.
Correspondence School, Locomotive Engineering, 501, 551.
Cuba, Railroads of, 246.
Cylinder Lubrication, 63, 213.
Cylinders, *Top Wear of, 257.

D

Discipline, Carelessness About Enforcing, 112.
Draw Bar, Side Clearance of, 349.
Draw Gear, *Rough Handling of, 56.
Driving Axles Get Cracked in Wheel Lugs, 160.

E

Education, *Technical, in Russia, by L. Lodien, 299.
Electric, High Speed on Germany Railway, *1.
Locomotive, High Speed of, 521.
Principal, Units, 30.
Traveling Crane, 6.
Electric Headlights, Discussion on, 314.
Failures of, 504.
Engine, Allis-Chalmers', 49.
Failures of, 164.
Engines, Compound, 16.
Turbine for Atlantic Steamers, 57.
Engineers, Ways of Good, 490.
When Reliable, Were Scarce, 55.
Work of Traveling, 408.
Enginemen, Vision of, 547.
Examinations on New York Central, 408.

F

Fellow Servant Law, Supreme Court Upholds, 261.
 Firemen, Defending the, 566.
 Give the a Chance, 266.
 Modern, 547.
 Training of, 111.
 Firing, Good and Bad, 207, 3rd.
 Flue, *Testing Apparatus, 189.
 Flues, Leaky, 54.
 Foremen, Round House, 336.
 Forge, Sturtevant Portable, 573.
 Freight, Cost of Moving, 246.
 Front Ends, Locomotive, 353.
 Theories About, 360.
 Troubles With, 444.
 Fuel, *Economizer, 255.
 Furnace, *Metal Melting, 94.

G

Galena *Oil Company, Product of, 372.
 Gauge, *Inspirator Valve, 366.
 *Steel Tire Flange, 309.
 General Electric Company, Tests of Street Car Motor, 425.
 Grade Crossings, Danger of, 258, 310.
 Grate Surface, Large, 400.
 *Growth of the Locomotive, by Angus Sinclair, 3, 59, 174, 202, 263, 322, 345, 392, 437, 484.

H

Headlights, Discussion of Electric, 314
 Electric, 504.
 Failures of Electric, 504.
 Heater, New Baker, 99.
 Heaters, Ancient Steam, 216.
 Heating Surface, Value of, 298.
 Horsepower, Calculating, 297.
 Easy Way of Calculating, 2.

I

Illinois Central, Facts About, 404.
 Indicator, *Star Brass Manufacturing Company's, 328.
 Injured, First Aid to the, 499.
 International Railway Congress, Proposed Exhibition at, 452.
 Interstate Commerce Commission, Accident Bulletin, 421.
 Report of, 495.
 Inventor, the Poor, 166.
 Iron, New Method of Brodzing, 463.

J

Jack, Barretts' Ratchet Lever, 92.
 Handy, 93.
 Norton, 95.

K

Knot, The Length of a, 247.

L

Library, Value of a, 53.
 Link Motion, Inventor of, 167.
 *Real Inventor of, 128.
 Reflections on, 158.
 Locomotive Engineers—Objecting to Term, 549.
 Pensions for War Time, 213.
 Locomotive, *Adriatic Railway, 4-6-0, 356, 357.
 *American Locomotive Company, 4-6-0 for Toronto, Hamilton & Buffalo, 363.
 Ancient, 241.
 *Austrian State Railways, 153.
 *Baldwin, 4-6-2 for El Paso South Western, 15.
 *4-6-0 for Seaboard Air Line, 55.
 *4-6-0 for Atlantic Coast Line, 81.
 *4-6-0 for Louisville & Nashville, 103.
 *4-4-2 for Union Pacific, 137.
 *2-8-0 for Japanese Government, 227.
 *4-5-0 for Erie, 231.
 *4-6-2 for Richmond, Fredericksburg & Potomac, 281.
 *2-8-0 for Chicago, Milwaukee & St. Paul, 325.
 *2-6-0 for St. Joseph & Grand Island, 349.
 *Suburban for Long Island Railroad, 397.
 *Four Cylinder Balanced Compound for Chicago, Burlington & Quincy, 464, 465.
 *4-6-0 for Lehigh Valley, 495.
 *Balanced Compound, 4-6-0 for New York, New Haven & Hartford, 559.
 *4-6-2 With Vanderbilt Tank for Union Pacific, 184.
 *Beyer, Peacock & Co.'s 4-4-2 for Great Central, 131.
 *Boston & Maine, 2-6-0, 47.
 *Brooks Heavy, 2-8-0 for Lake Shore, 31.
 *4-4-2 for Wabash, 73.
 *2-6-2 for Lake Shore, 440.
 *4-6-2 for Missouri Pacific, 483.
 *Canadian Pacific 2-8-0 with Schmidt Super-Heater, 545.
 *Canadian Locomotive Company's 4-4-0 for Prince Edward Island Railway, 471.
 *Chart No. 7, 345.
 *Chicago, Burlington & Quincy, 2-6-2, 21.
 *Coles' Schenectady Balanced Compound 4-4-2 for New York Central, 273.
 *Compound on Swedish State Railways, 12.
 *Curious Express, 14.
 *Development of the Eight Wheel Connected, by J. Snowden Bell, 27.
 Economical Load of, 64.
 *Electric, for Reading, 519.

*Electric, High Speed of, 531.
 *English, 4-4-0 Compound, 221.
 *Fireless Steam, 6.
 First Brought into Iowa, 132.
 Frames, 41.
 Front Ends, 79.
 Front Ends and Steam, 353.
 *General Electric, 286.
 *German Built for Eastern of France and for Portugal, 111.
 German School of, 392.
 *Great Indian Peninsular Railway, 4-6-0, 487.
 *Great Western of England, 4-6-0, 251.
 *Growth of, by Angus Sinclair, 3, 59, 174, 202, 263, 322, 345, 392, 437, 484.
 Louisville & Nashville, 120.
 Names on Our Educational, Chart, 362.
 *New Zealand Engine, 253.
 *Old "Philadelphia," 109.
 *Old Time "Brakenhead," 154.
 Passing of the American, 406.
 *Pennsylvania, 4-4-2, 77, 78.
 *Pennsylvania Railroad De Glehn Compound, 246.
 *Pennsylvania, 4-4-2, 343.
 *Pennsylvania Testing Plant at St. Louis, 22, 133.
 Petrol, 536.
 Race with Motor Car, 536.
 *Record Board, 330.
 *Richmond Tandem Compound 2-8-0 for Northern Pacific, 183.
 *Rhode Island 2-8-0 for Queen & Crescent, 105.
 *Rogers 4-6-0 for Nashville, Chattanooga & St. Louis, 150.
 *2-6-0 for Cotton Belt, 247.
 *2-8-0 for Great Northern, 405.
 *Schenectady 4-6-0 for Chicago & Northwest-ern, 20.
 *2-8-0 for Erie, 163.
 *4-4-2 for Michigan Central, 199.
 *4-6-2 for New York Central, 211.
 *Mallet Four Cylinder Articulated Compound, 283.
 *2-8-0 for Chicago, Burlington & Quincy, 327.
 *4-6-2 for Michigan Central, 419.
 *Southern Pacific 2-8-0, with Vanderbilt Tank, 507.
 *Superheater, 544.
 *Section of Electric, 532.
 *South African with Walschaert Valve Gear, 535.
 *Stevens on Southern Pacific, 403.
 *Suburban Tank for Lancashire & Yorkshire, 151.
 *Ten Coupled Tank for Prussian State Railways, 155.
 Tests at Lowell in 1851, 63.
 Locomotives, American, in Germany, 440.
 Big Output of, 78.
 Blows and Pounds in Simple, 77.
 Built in 1903, 99.
 Early, in Michigan, 305.
 Handling Leaky, 543.
 Mason, 370.
 Mileage of Switch, 359.
 Old American in Russia, 307.
 Wilmarth, 21.
 Lubrication of Valves and Cylinders, 213.
 Lubricator, Detroit Lubricators, New, 47
 Positive, 462.

M

Machine Tools, *Norton Grinding Machine, 44.
 *Sellers' Wheel Lathe, 45.
 *J. A. Fay and Egan Ripping Saw Table, 46.
 *Acme's 2-inch Bolt Cutter, 50.
 Getting Work Out of, 58.
 History of, 68.
 *Flue Expanding and Swaging, 80.
 *Unique Tool Holder, 95.
 *Niles-Bement-Pond Quartering, 96; and 36-1n. Lathe, 576.
 *Cincinnati Company's Crauk Shaper, 97.
 *Gould and Eberhardt's Shaper, 98.
 *Ingenious Tube Expander, 106.
 Rating of, 117.
 *Automatic Car Gainer, 141.
 *Niles Cylinder Boring, 142.
 *Cincinnati Double Headed Shaper, 143.
 *Wheel Rotating Apparatus, 144.
 *Long and Allstatter Punching and Shearing Machine, 145.
 *Bullard Boring and Turning Mill, 146.
 *Automatic Band Rip Saw Fay & Egan, 192.
 Handy Lathe Appliance, 238.
 *Power Feed Sander, 240.
 *Taylor Newbold Cold Metal Saw, 280.
 *Fay & Egan Company's Rip Saw, 337.
 *Sanders Pipe Threading Machine, 338.
 *Cleveland Punch, 339.
 *Lodge & Shipley's Double End Axle Lathe, 340; Projectile Lathe, 370.
 *New Lodge & Shipley Lathe Head, 378.
 *Bickford's Semi-Radial Drill, 387.
 *Imperial Radial Drill, 388.
 *Fay & Egan Automatic Band Rip Saw, 389.
 *Higley Cold Metal Saw, 431.
 *Fay & Egan Lightning Floorer, 432.
 *Newton Cold Metal Cutting Off Machine, 433.
 *Pond Steel Tired Wheel Lathe, 468.
 *Blake & Johnson Screw Thread Rolling Machine, 477.
 *Lodge & Shipley's Lathe, 521.
 *Landis' Bolt Cutter, 523.
 *Clmax Regulating Valve, 524.
 *Bement-Niles 20-inch Slotting Machine, 526.
 *Fay & Egan's Hollow Chisel Mortiser, 529.

McConway & Torley's Car Coupler, 530.
 Manifold *Company Works at Franklin, Pa., 420.
 Master Car Builders, *Drop Testing Plant of, 539.
 Proceedings of, 549.
 Master Mechanics, The, Convention, 260; Committees for 1904-5, 382; Ask to Pay for Experiments, 261.
 Memory, Means of Helping, 161.
 Metals, Drilling Hard, 257.
 Fatigue of, 535.
 Miscellaneous, Cheating by the Endless Chain, 10.
 Progress, 11.
 Value of Knowing Common Things, 17.
 Untidiness and Waste, 17.
 Helping to Make Hard Times, 17.
 Inherited Cleverness, 56.
 Power of Habit, 57.
 Printers' Ink, 84.
 Last Call for Dinner in the Dining Car, 102.
 Bend the Twig, 111.
 Old Time Railroad Reminiscences by S. J. Kidder, 138, 395.
 Reminiscences of the Early 60's by Shandy Maguire, 151.
 Truth is Better Than Comfortable Error, 165.
 Ancient Winters, 188.
 A Good Stop Made by a Plucky Man, 188.
 Unexpected That Often Happens, 197.
 Scenes in California, 205.
 Influence of a Female Drummer, 227.
 Influence of Brain Power on Dividends, 231.
 How a Bolt Machine Seller Sold a Machine and Bolted, 307.
 Knowledge and Skill, 310.
 As Others See Us, 361.
 Reminiscences of Apprenticeship, 402.
 Laziness, 410.
 A Told You So Man, 441.
 Expensive Conflicts of Authority by Shandy Maguire, 448.
 Trip on the Big 2700 by Angus Sinclair, 515.
 *Group of Electric and Technical Press Men, 533.
 Neglecting the Stitch, 559.
 Mistakes We Have Made, 157.
 Precious, the Engineer, 576.

N

Nozzles, Size of, 76.

O

Obituaries, Thos. Cyprian Freyyear, 86.
 Calvin A. Smith, 86.
 Wm. Tootie, 135.
 Edw. A. Phillips, 183.
 John L. Weeks, 230.
 Thos. Downie, 230.
 Robt. Sample Miller, 230.
 John Reilly, 230.
 Peter Petrie, 278.
 J. M. Barr, 280.
 Jas. A. Henson, 280.
 T. S. Ingraham, 280.
 Saml R. Callaway, 280.
 Observation Properly Applied, 232.
 Organization, Power of, 498.

P

Packing Leaky Rod, 213.
 To Test Cylinder, 356.
 Panama, Facts About, 542.
 Patents, Air Brake, 236.
 Paterson, Rise of, 108.
 Pennsylvania Railroad Work in New York City, 156.
 Piston Rod Packing, *Self-Adjusting 67.
 Piston Packing, Development of, 451.
 Piston Valves, Setting, by Ira A. Moore, 104.
 Article on, 208.
 Device to Assist in Setting, 364.
 Guide for, 421.
 Inside Admission, 565.
 Plate Rack in the Wheel Shop, 155.
 Portraits, Thos. Rogers, 3.
 Geo. S. Griggs, 61.
 Ralph Little Whyte, 128.
 Geo. W. Wildin, 134.
 Wm. Tootie, 135.
 Wilson Eddy, 174.
 Wm. Mason, 177.
 Saml. Higgins, 182.
 Seth Boyden, 204.
 F. D. Underwood, 277.
 Geo. J. Gould, 278.
 Jas. White, 278.
 Peter Petrie, 278.
 Julius Kruttschnitt, 279.
 Wm. Swinburne, 323.
 Wm. Hudson, 323.
 John Cooke, 323.
 Albert J. Pitkin, 329.
 W. H. Lewis, 330.
 Peter H. Peck, 330, 277.
 Warren S. Stone, 375.
 W. E. Symons, 375.
 W. P. Appleyard, 376.
 John Kirby, 376.
 W. E. Fowler, 376.
 Wm. McIntosh, 377.
 H. F. Ball, 377.
 J. F. Deems, 377.
 Angus Sinclair, 377.
 E. H. Harriman, 423.
 E. T. Jeffrey, 423.
 Jas. J. Hill, 423.

Portraits, Jas. B. Brady, 163.
 Coleman Sellers, 484.
 A. W. Sullivan, 513.
 B. L. Winchell, 513.
 Frank Hedley, 513.
 Power, Water and Coal, 436.
 Progress, Watching Scientific, 312.
 Pump, General Electric's High Speed, 326.

Q

Questions and Answers, 19, 72, 120, 167, 215,
 262, 315, 361, 410, 454, 504, 553.

R

Race, Transcontinental, With Mall, 391.
 Rapid Transit in New York City, 546.
 Rail, Creeping of Left Hand, 273, 357.
 Rail Loader, *Air Operated, 512.
 Railroad, Dangers of Early, Locating, 6.
 Revenues of a Year, 62.
 Expansion, 108.
 Pictures of Machinery on Lumber, 209.
 And Photography, 255.
 Railroad Men, Training of, 214.
 Railroads, *of Cuba, 246.
 Railway, High Speed on German Electric, 1.
 *Trolley in Canada, 118.
 Southern Pacific, Improvements, 132.
 *Scenes in North Borneo, 249.
 *Mt. Pilatus,
 Proposed High Speed, 462.
 Trans-Siberian, 500.
 Collection of Antiquities, 548.
 Railways, Political Management of, 250.
 Repairs, General and Running, by Jas. Kennedy.
 Reverse Lever, Position of, on Piston Valve
 Engines, 12.
 Care of, 492.
 Rogers Locomotive Works, *Illustrations of,
 3-4.
 Roundhouse, Conveniences in, 11.
 *Square, 285.
 Foremen, 313, 336, 399.
 Roundhouses, H. H. Vreeland on Electric, 298.
 Rubber, Process of Making Hard, 469.

S

Sander, Convertible, 282.
 *For Wet Sand, 398.
 *Handy, 370.
 *New, 558.
 School, Correspondence, 501, 551.
 Schools, German Locomotive, 392.
 Prussian Railway, 155.
 Sellers' New Planer, Exhibit of, 273.
 Shoes and Wedges, Laying Off, 442, 543.
 *Percy's Method of Laying Off, 355.
 *Lining Up, 443.
 Shop, Curious, Operations, 41.
 Ideal Blacksmith, 534.
 Management, 308.
 Modernizing an Ancient, 541.
 Out of Sympathy With Men, 453.
 Shops, *Canadian Pacific, the Angus, 371.
 Florida East Coast, 397.
 Shop Appliances, *A Handy Shop Turn Table,
 472.
 *Air Operated Grinder, 550.
 *Boiler Plate Suspension Clamp, 259.
 *Cheap Crane, 520.
 *Cutter for Piston and Valve Packing Rings,
 470.
 Double Cutter for Rocker Arms, 470.
 *Expanding and Beading Tool, 494.
 For Moving Tenders, 232.
 *Handy, at Wilkesbarre Shops, 198.
 *Handy Drop Forge, 466.
 *Handy Trestle, 190.
 Handy Wheel Hoist, 558.
 *Keyway Cutter, 316.
 *Pohlman's Micrometer Tool for Boring Ma-
 chine, 445.
 *Portable Bronze Furnace, 550.
 *Portable Frame Forge, 480.
 *Pinch Bar and Cross Head Moving Bar, 470.
 *Repairing a Cracked Engine Frame, 332.
 *Rotary Planer for Rod Brasses, 445.
 *Slotter Bar and Other Handy, 136.
 *Stud Extractor, 494, 471, 490.
 *Tender Lifter, 382.
 *Tester for Pop and Relief Valves, 466.
 Tool for Turning Tumbling Shaft, 470.
 *Turning Tool for Lifting Shaft Journals, 470.
 *Wrist Pin Nut Lock, 354.
 Signal, Railroad Cab, 307.
 Signals, *Union Switch and Signal Company's
 Exhibit Rooms, 24.
 Running Past Extinguished, 84.
 Signals and Signaling, *by George S. Hodgins,
 7, 74, 113, 178, 252, 351, 454, 492, 567.
 Slipping With Steam Shut Off, 27, 67, 112, 113,
 159, 160, 205, 208, 256.
 Snow Plow, *Rotary, at Work, 53.
 Spark Arrester, German, 162.
 Latest Fake, 442.
 Speed, *High, Electric Locomotive, 531.
 Of Wing Flyers, 446.
 Speeds, Fictitious High, 110.
 Springs, *Underhung, 2.
 Standards, Master Car Builders, 118.
 Revision of Master Mechanics, 380.
 Staybolts, Breakage of, 68.
 New Radial, 402.
 Tate Flexible, 239.
 Steam, Use of Superheated, 516.
 Steamship, Baltic, 364.

Steel, Break in Price of, 407.
 Critical Heat of, 261.
 Modern Methods of Making, 496.
 Sorbille, 2.
 *Tank Car, 569.
 Steel Rules, How Made, 226.
 St. Louis Exposition, Armstrong Bros. Exhibit,
 473.
 Awards to the Westinghouse Company, 516.
 Carborundum at, 311.
 Pennsylvania Testing Plant at, 22, 136, *411.
 Railway Machinery at, 231.
 Russia's Only Building at, 475.
 Science, Art and Industry at, 251.
 Stoker, Locomotive, Company, 560.
 Lucky Locomotive, 255.
 Mechanical, 359.
 Stopping With Engine Reversed, 164.
 Stud, *Extracting a Broken, 471, *490, 494.
 Success, How to Earn, 178.

T

Tank, Fittings Around, by Jas. Kennedy, 384.
 Temperature, Flame, 298.
 Timber, Railroads Ought to Cultivate, 100.
 Train Despatcher, Work of, 436.
 Train, *Indian, de Luxe, 487.
 Loaded With Historical locomotives, 150.
 North Coast Limited, 156.
 Overtime in Operation, 497.
 Trans-Siberian, 245.
 Train Order Holder, Need for Good One, 136.
 Train Orders, Abbreviation of, 214.
 Trainmen, Behavior of Elevated, 491.
 Transportation, Low Cost of, by J. J. Hill, 215.
 Trees, Annual Ring of, 465.
 *Cutting Down Giant, 82.
 Truck, *Andrews Solid Steel, 511.
 *The Bettendorf, 381.
 *Wright's Tender, 282.
 Tunnel, *Radebaugh on Pennsylvania Railroad,
 101.
 *Section of Pennsylvania, 418.
 Simplon, 481.
 Turbines, Steam, 440.

V

Valve, *Baldwin Piston, 56.
 Is the Relief, a Failure? 574.
 Lubrication, 63.
 *Setting Model, 191.
 *Star Relief, 383.
 *Testing Device, 372.
 Cut Off, 401.
 Valve Gear, The Allfree, 11.
 Valve Motion, *Direct and Indirect, 500.
 *Walschaert, 534.
 Valves, Setting Piston by Ira A. Moore, 104.
 Piston, 208.
 Lubrication of, 213.
 Blows in, 356.
 *Safety, for Tank Cars, 558.
 Viaducts, *On Chamoni Railway, Switzerland,
 481.

W

Warning, Failing to Heed, 442.
 Water Changing, *Pittsburg & Lake Erie Ap-
 paratus, 509, 538.
 Water, Simple Tests for, 238.
 Softener, 316.
 Wheels, Forged Rolled Steel Car, 83.
 Paper, 10.
 Winans, Ross, Work of, 106.

"Twentieth Century Locomotives,"

By ANGUS SINCLAIR COMPANY.

Price, \$3.00.

This is a book of 700 pages, same size as the Railway Master Mechanics' Association and railroad club reports.

The book treats of the principles and practice underlying the designing, construction, repairing and operating of railway machinery.

The book has been prepared for the use of all railway men eager to learn things about railway machinery, but more particularly for superintendents of motive power, master mechanics, master car builders, mechanical engineers, shop foremen, engineers, firemen and shopmen.

Among the subjects discussed are:
 ELEMENTARY LESSONS ON
 FIRST PRINCIPLES STEAM AND
 MOTIVE POWER.

WORKSHOP OPERATIONS; which

includes illustrated methods of doing repair work.

VALVE MOTION; which illustrates and describes slide and piston valves and methods of setting them.

CARE AND MANAGEMENT OF LOCOMOTIVE BOILERS.

COMPOUND LOCOMOTIVES; which illustrates and describes the leading types of compound locomotives. There are several articles by leading authorities on how to handle and take care of compound locomotives.

OPERATING LOCOMOTIVES; a chapter which alone would make a useful handbook for young engineers.

SHOP MECHANISM; illustrates and describes the machinery used in doing repair work.

FORCES INVOLVED IN TRAIN MOVEMENTS.

INJECTORS.

SIGHT-FEED LUBRICATORS.

ELECTRIC HEADLIGHTS.

THE STEAM ENGINE INDICATOR.

ILLUSTRATIONS OF LOCOMOTIVES; illustrates and describes about 200 locomotives which have been built during the Twentieth Century.

A prominent superintendent of motive power who examined the unbound pages wrote: "It is the best book for railroad men since yours and Forney's books came out."

Setting Valves of Angus Sinclair Company's Model.

Nearly every intelligent man connected with locomotive maintenance or operation desires to understand how to set valves; but very few people have an opportunity to learn how the work is done. By the aid of the valve motion model, now handled by the Angus Sinclair Company, any person can learn to set valves just as easily as if he had a real locomotive to experiment with. All the parts that are adjustable in the valve motion of a real engine are adjustable in this model. The eccentrics can be rotated on the shaft to any position, the eccentric rods and the valve stem can be changed in length and the hanger stud of the link being secured to a sliding block, the point of suspension can be changed to adjust the cut-off. That feature and the movable eccentrics give good opportunity to experiment as to how the valve motion is often out of square. A piston valve can be put in to replace the slide valve when that is desired. It is the best valve motion model ever offered, at a price within the reach of ordinary engineers or shopmen.

This model is sent, expressage paid, for \$15.00, or 25 subscriptions to RAILWAY AND LOCOMOTIVE ENGINEERING, or 15 subscriptions to the *Automobile Magazine*.

BOOK DEPARTMENT

Address RAILWAY AND LOCOMOTIVE ENGINEERING, 136 Liberty St., New York

Cash must accompany order. No books sent C. O. D. Give name of book and author, and we can furnish any book published. The list below is especially recommended for mechanical readers. All books sent by mail free for price named, unless otherwise stated.

A B C OF ELECTRICITY. By Wm. H. Meadowcroft. The best-known elementary treatise on this interesting subject. Written in language that is easily understood. Fully illustrated. Over 60,000 have been sold.\$50c.

AIR-BRAKE CATECHISM. By Robert H. Blackall. The Eighteenth Revised and greatly enlarged edition. This book is a complete study of the Air-Brake Equipment, and includes the latest devices and inventions used. All parts of the air-brake, their troubles and peculiarities and a practical way to find and remedy them, are explained. 310 pages, 100 illustrations and 11 folding plates, including three printed in colors. Eighteenth edition.\$2.00

THE 1904 AIR-BRAKE CATECHISM. Conger. Convenient size, 202 pages, well illustrated. Up to date information concerning the whole air-brake question, in question and answer form. Instructs on the operation of the Westinghouse and the New York Air-Brakes, and has a list of examination questions for engineers and trainmen. Bound only in clothPrice, \$1.00

ARITHMETIC OF ELECTRICITY. By Prof. Sloane. Shows how calculations are made which are necessary to electrical work. Examples are given and plainly worked out. 138 pages\$1.00

BINDERS FOR LOCOMOTIVE ENGINEERING. These are the handiest, and most substantial binders we could find. Hold a year's papers. No trouble to put them in or take them out; no holes to punch or strings to lace. Have paper's name stamped in gold on cover. Post-paid\$1.00

BLACKALL'S WESTINGHOUSE AIR-BRAKE CHART. An up-to-date Air-Brake Chart, printed in ten colors, showing the different connections from the engine to the train. The Pump, Engineer's Valve, Triples and all parts used of the system. Printed on heavy bond paper. Every student of the Air Brake should possess it, as it is a complete Air-Brake Course in itself.\$1.00

BOILER MAKER'S ASSISTANT. By John Courtney. This book teaches people to lay out boilers. It is simple and unpretending, but the rules will be easily understood by thoughtful workmen\$1.00

BOILER MAKING FOR BOILER MAKERS. W. H. Ford. 1897. A practical treatise on the shop processes of boiler making. 233 4 x 5 1/2 inch pages, 234 illustrations.\$1.00

CAR LUBRICATION. Hall. Ought to be read by every one interested in keeping journals running cool.\$1.00

CARE AND MANAGEMENT OF LOCOMOTIVE BOILERS. The best book on this subject that we know of. Also contains several chapters on oil burning locomotives and gives actual practice in the Southwest.\$50c.

CATECHISM OF ELECTRICITY. N. Hawkins. This contains enough questions and answers to give any mechanic a pretty general knowledge of electricity as applied to modern uses. Its 650 pages and 300 illustrations are full of information for the mechanic.\$2.00

CATECHISM OF THE LOCOMOTIVE. Forney. 1891. Enlarged. Illustrated. 50,000 sold. Every beginner wants it, and every locomotive engineer ought to have it. 300 5 1/2 x 8-inch pages\$3.50

CATECHISM OF THE STEAM PLANT. Hemenway. Contains information that will enable one to take out License to run Stationary Engine. Tells about Boilers, Heating Surface, Horse Power, Condensers, Feed Water Heaters, Air Pumps, Engines, Strength of Boilers, Testing boiler performances, etc., etc. This is only a partial list. Question and answer style, 128 pages; pocket size.\$50c.

COMPOUND LOCOMOTIVE, THE. Colvin. A leather bound pocket-book describing and illustrating compounds in use in this country. Tells about running, breakdowns and repairs\$1.00

COMPRESSED AIR; PRACTICAL INFORMATION UPON AIR COMPRESSION AND THE TRANSMISSION AND APPLICATION OF COMPRESSED AIR. Frank Richards. 1895. About the only book in print that supplies the information on this important subject that so many are in search of. A practical book without mathematical ornamentation. 195 5 x 7 1/2-inch pages. 25 illustrations and diagrams, with many useful tables.\$1.50

DISEASES OF THE AIR-BRAKE SYSTEM. Synnestvedt, 1894. Tells how to find and repair every defect that the air-brake system is liable to have.\$1.00

EXAMINATION FOR PROMOTION. Thompson. This is a catechism of the locomotive by the Secretary of the Traveling Engineers' Association. It comprises the questions and answers that are best adapted for the examination of men for promotion. Very few things that an engineer ought to know are omitted. Nothing better can be found for a man preparing to pass an examination. Bound in leather, 75 cents; in cloth.\$50c.

FIRING LOCOMOTIVES. By Angus Sinclair. Treats in an elementary way the principles of combustion. Is easily understood by every intelligent fireman and is a convenient reference\$50c.

GAS ENGINE HANDBOOK. By E. M. Roberts. One of the best books published for those who are interested in the design and operation of gas and gasoline engines.\$1.50

GAS, GASOLINE AND OIL VAPOR ENGINES. Gardner D. Hiscox. 1898. The latest book on this interesting and important subject. Has chapters on the horseless carriage as well as on the leading makes of engines.\$2.50

HASWELL'S ENGINEER'S POCKETBOOK. 1894. Probably the best authority in engineering matters. Rules for almost everything. \$4 00

INDICATOR PRACTICE AND STEAM ENGINE ECONOMY. F. F. Hemenway. 1890. Thoroughly practical and useful. Gives much information on the action of steam in the steam cylinder, and in language which anybody can understand who will try. 184 5 x 7 1/2-inch pages; 45 illustrations.\$2.00

LINK AND VALVE MOTIONS. W. S. Auchincloss. 1895. A work that has been standard for a quarter of a century, especially on link motions. Newly revised. 138 8 1/4 x 8 1/4-inch pages; 52 illustrations.\$2.00

LOCOMOTIVE BREAKDOWNS AND EMERGENCIES AND THEIR REMEDIES. By Geo. L. Fowler, M.E. It is written in catechism form. Accidents liable to happen to engines on the road. Gives quick easy methods of making repairs and preventing serious blocking of the line. Repairs are made with ordinary appliances such as are usually within the reach of engineer and fireman. Profusely illustrated. Is a valuable guide to men anxious to be able to cope with any emergency. Price\$1.50

LOCOMOTIVE ENGINE RUNNING AND MANAGEMENT. Angus Sinclair. 1899. New edition just revised and brought thoroughly up to date. Has a valuable Air-Brake Department. Gives the Questions and Answers of the Traveling Engineers' Form of Examination in full. Complete information about the locomotive of to-day, and most of the difficulties met with in handling them.\$2.00

LOCOMOTIVE LINK MOTION. Fredk. A. Halsey. 1898. This explains slide valves and hook form by a leading publisher and sell their use with the link motion in a clear and practical manner which can be readily understood by any mechanic. It is fully illustrated and is sure to be appreciated by the many who are anxious to become familiar with this important feature of the locomotive.\$1.00

LOCOMOTIVE RUNNING REPAIRS. Hitchcock. 1893. A practical treatise on running repairs by a practical man. Numerous diagrams and illustrations. 110 4 1/2 x 7-inch pages.\$50c.

LOCOMOTIVE, SIMPLE, COMPOUND, AND ELECTRIC. Reagan. An excellent book for people interested in any kind of locomotive. It will be found particularly useful to men handling or repairing compound locomotives.\$2.50

THE LOCOMOTIVE UP-TO-DATE. McShane. 736 pages, size 6 x 9 inches; 350 illustrations, bound in fine cloth.\$2.50

MACHINE SHOP ARITHMETIC. Colvin & Cheney. 1896. Plain rules showing shop men how to calculate speed of pulleys and gearing, how to figure the gears for screw cutting, and giving a great many facts about tools which every mechanic ought to understand.\$50c.

MECHANICAL ENGINEERS' POCKETBOOK. Kent. This book contains 1,100 pages 6 x 3 1/4 inches of closely printed minio type, concerning mechanical engineering matters. It ought to be in the book case of every engineer who takes an interest in engineering questions. We use it constantly as a reference for ques-

tions sent to us to be answered. Full of tables and illustrations. Morocco leather.\$5.00

NEW YORK AIR-BRAKE CATECHISM. By Robert H. Blackall. Deals fully with the New York Air Brake Company's equipment. Illustrated description of all parts. Peculiarities, troubles and care of the brake system. 254 pages good, clear, line cuts written by a practical man. The latest thing on the N. Y. Brake. Price\$1.25

ONE THOUSAND POINTERS FOR LOCOMOTIVE ENGINEERS AND MACHINISTS. McShane. 1896. A book containing information of the greatest value on the locomotive. Covering the air brake, valve motion injectors, lubricators and everything of interest to the machinist and engineer.\$1.50

PRACTICE AND THEORY OF THE INJECTOR. Kneass. 1895. The only complete work on the injector yet published. All about all kinds of injectors. 132 5 1/4 x 9-inch pages.\$1.50

PROGRESSIVE EXAMINATIONS OF LOCOMOTIVE ENGINEERS AND FIREMEN. Hill. 1893. Three hundred questions and answers to them, on firing and running locomotives\$50c.

SIMPLE LESSONS IN DRAWING FOR THE SHOP. Reynolds. 1893. Twelve lessons that can be done with a \$10 set of instruments. The rudiments of drawing in the best form. 83 4 x 6 1/2-inch pages.\$50c.

SKEEVERS' OBJECT LESSONS. Hill. A collection of the famous Object Lessons which appeared in this paper several years ago. They are interesting, laughable, and best of all, are of practical value. Cloth bound.\$1.90

SLIDE VALVE GEARS. F. A. Halsey. 1898. Full of diagrams, but no mathematics. Makes the slide valve as plain as words can do it. 135 5 x 7 1/2-inch pages; 79 illustrations.\$1.50

SPANGENBERG'S STEAM AND ELECTRICAL ENGINEERING. By Messrs. E. Spangenberg, A. Uhl, and E. W. Pratt. 1904. A reference work for engineers, electricians, firemen, linemen, wiremen, steamfitters. Treats of stationary and locomotive engineering, electricity, compressed air, mechanical refrigeration, gas and gasoline engines, hydraulic elevators, repair work, etc. 672 pages, partly in question and answer form.\$3.50

STANDARD EXAMINATION QUESTIONS AND ANSWERS ON THE AIR BRAKE. All about air brakes, both Westinghouse and New York, their construction, operation, disorders, symptoms and cures. Most complete book on air brakes yet printed. Will pass you through anybody's air-brake examination.\$25c.

STANDARD TRAIN RULES. This is the code of Train Rules prepared by the American Railway Association, for the operating of all trains on single or double track. Used by nearly all railroads. Study of this book would prevent many collisions.\$50c.

STORIES OF THE RAILROAD. Hill. These include the Engineer's Christmas story and others which were first written for Locomotive Engineering. They have been put together in for\$1.50

THE PRACTICAL MANAGEMENT OF DYNAMOS AND MOTORS. Crocker and Wheeler. Both are professors and manufacturers, know both sides of the question, and tell it in plain English. Best book of the kind we know of. 210 pages\$1.00

THE TRACKMAN'S HELPER. J. Kindelan. A practical book on the subject of track and track work, especially written for the use of section foremen\$1.50

TRAIN RULES AND TRAIN DISPATCHING. By H. A. Dalby. Pocket size 6 1/2 ins., bound in leather. Train dispatching rules discussed, their meaning and scope explained. Forms of orders. Advice to operators, dispatchers, engine and trainmen. Standard Code reproduced with color plates. Useful to men in the office and on the road. Price.\$1.50

TWENTIETH CENTURY LOCOMOTIVES. By Angus Sinclair Company. It has 670 pages dealing with the designing, constructing, repairing and operating of modern locomotives. Work shop operations, care and management of engines. Quick repairs on the road, shop tools, shop receipts, train resistance and power calculations, definitions and tables. Standard types of engines illustrated and described. Fully indexed. Most all round useful modern compendium of the locomotive. Price.\$3.00

Railway and Locomotive Engineering

Copyright by Angus Sinclair Co.—1903

A Practical Journal of Railway Motive Power and Rolling Stock

Vol. XVII.

174 Broadway, New York, January, 1904

No. 1

High Speed spurts and Average Performance.

The high speeds attained on the German experimental railway between Marienfelde and Zossen may be regarded in a measure as laboratory tests. It is true that a rate of 125 miles per hour was actually attained, but for only a short period of time. Mr. Pritchett, president of the Massachusetts Institute of Technology, who witnessed the speed trials, is said to have been sufficiently impressed

not a practical one if by that we mean the pushing up of average train speeds to anything like that point. To maintain excessively high average speeds, the building, or rather the rebuilding of perma-

travel is concerned, but at no point in the whole process have we ever made a sudden and very long jump ahead. The process is, however, still going on as an orderly evolution, in which safety and speed move forward together. The process is a slow one and our advance in average speed has not been relatively so very great. We run a little faster on the average than we did when railroads were new, but we now run with far greater safety.



WAR TIME (1863) PICTURE OF HARRISBURG STATION, PENNSYLVANIA RAILROAD.
Photograph received from Mr. J. B. Hutchinson, Assistant to 2d Vice-President.

with what he saw as to say that he was of the opinion that 100 miles an hour is a practical speed for railway operations.

We cannot wholly agree with President Pritchett in this, for it must be remembered that these very high speeds have so far only been made on the specially prepared Marienfelde-Zossen military line, and this fact is proof only that they are mechanically possible. A speed of 100 miles an hour could, no doubt, be made for short distances on many roads in this country, but the speed is

ment way suitable for the passage of trains is only the first part of the problem. The maintenance of the line so built is the second part, and the motive power department and the vehicle builder would have to be reckoned with, if safe and rapid train movement was to be secured.

We have reached a point in the solution of transportation problems where safety is perfectly consistent with speeds which thirty years ago would have been out of the question, as far as security of

There may come a time when average safe speeds may be far ahead of present day practice, but the average speed of 70 miles an hour will have to come before the average of 80, and the average of 90 will have become familiar before that of 100 is reached.

There is another aspect of the high speed problem which should not be lost sight of. The use of an electric motor or motors enables greater concentration of power to be brought upon the driving wheels than is possible with a steam loco-

motive. The motor being at all times balanced, a much quicker acceleration of speed is possible. High speed, however, is very expensive, whether produced by locomotive or motor, and like other things, it is governed by the law of supply and demand. If the traveling public desire high speed they must pay for it at an advance on present fares. When they are prepared to pay for it, it will no doubt be forthcoming, but at present very high average speed is too costly to be commercially attractive in railway operation.

Underhung Springs and Breakdowns.

We are receiving numerous letters from enginemen in different parts of the continent to illustrate and give a rule of procedure with the underhung spring in case of derangement or breakdown. It speaks

No. 2 in Fig. 1 shows another arrangement favored by some designers and consists of two heart-shaped hangers resting on the top of the box and placed on both sides of the frame and extending down below the driving box to the spring similar to No. 1. It is the uncertainty on the part of the enginemen as to the direction of the forces that confuses him and makes him dread a breakdown with an underhung spring.

In No. 2 driving box, Fig. 1, we show a broken brass and where to block in a case of this kind. If the engine is provided with safety brackets over the equalizer, raise the equalizer with a jack or bar a sufficient height to take the weight off of the box and block at *a*, between safety bracket and bottom of equalizer. If there are no safety hangers, block between bottom of frame and top of equal-

forming the same operation at *b* and then *c*. This saves the tedious work of removing the springs, hangers and equalizers and No. 1 and No. 3 will carry the load.

Steel of Remarkable Properties.

Parties in Sheffield, England, are making what they call "sorbic steel," which appears to have remarkably valuable physical properties. *Engineering* shows a specimen cut from a 5½-in. square bar bent double upon itself without showing the least sign of crack or fracture. In its original state the bar had a tensile strength of 78,000 pounds, an elastic limit of 40,000 pounds and an elongation of 29 per cent. on a 2-in. test piece. It was then subjected to a special heat treatment, which is the secret of the makers when it was bent over cold without fracture. After the treatment the tensile strength was raised to 107,500 pounds to the square inch with an elastic limit of 85,000 pounds and 23 per cent. elongation. This steel ought to have a great future for the making of machines and structures where strength and lightness must be combined. It should increase considerably the possible span of bridges.

Easy Way of Calculating Engine Horse Power.

An easy way of figuring out the horse power of any engine is to use a constant which would be the power that would be developed in the cylinder at one pound pressure. To obtain the constant multiply the net area of cylinder by speed of the piston in feet per minute and divide the product by 33,000. The product will be the horse power for each pound mean effective pressure in the cylinder.

Take, for instance, a locomotive with cylinders 20 inches diameter. The area of the piston will be 314.16 sq. ins. Let there be 300 revolutions per minute of the driving wheels and 30 ins. stroke of piston, which gives a piston speed of 1,500 ft. per minute. Then you have $1,500 \times 314.16 \div 33,000 = 14$ h.p. for every pound of mean effective pressure in one cylinder. An engine working at that speed with 50 pounds indicated steam pressure would develop 1,400 h.p. in the two cylinders.

One More Question.

He had asked what makes the noise when an engine whistles and what makes a car go when the motor man twists the handle, and the wornout mother protested, "Now, go to sleep, Charlie."

"There's just one more question I wish to ask, Mamma. What comes of the piece that makes a hole in a stocking?"

Virtue is its own reward, so's jollity.—
Mark Tapley.

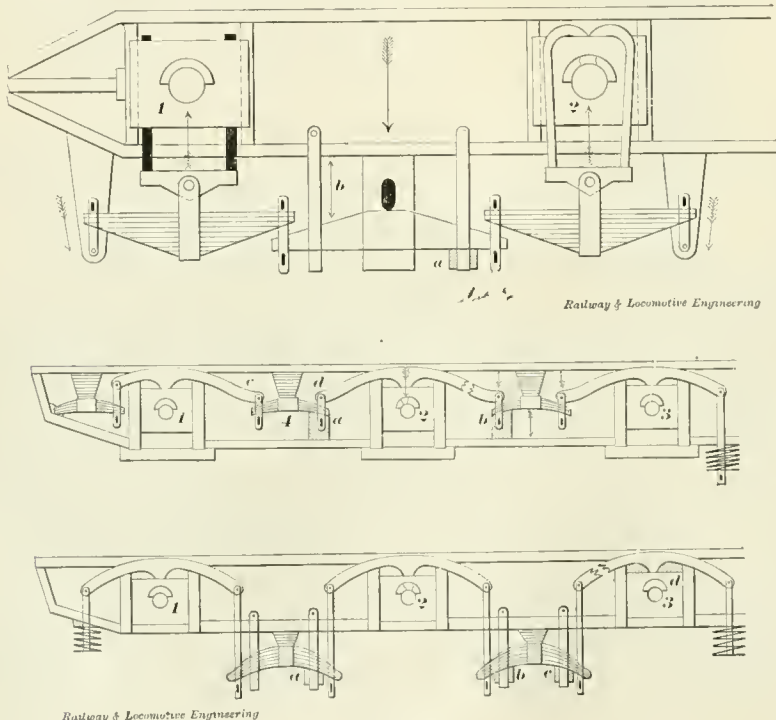

EXAMPLES OF UNDERHUNG SPRINGS.

well for them and shows that they are trying to master the obstacles in the way of progress. We would suggest to them to make a skeleton sketch of an engine, similar to those we illustrate and study the direction of the forces on the springs as indicated in Fig. 1. By following this rule one can take any type of underhung spring and master easily that which at first seems a very difficult problem and dispel the constant fear of not knowing what one would do in case of a breakdown.

In Fig. 1 we show two styles of hangers from the driving boxes, showing the direction of the stresses on the center and ends of the springs. No. 1 in Fig. 1 has four bolts passing through the box near the flanges and terminate in a cross bar from which the spring is suspended.

izer indicated at *b*. The arrows in Fig. 1 show the direction of the forces.

In Fig. 2 we have another type of underhung spring and equalizer. Here the driving box brass and equalizer over No. 2 are both broken. If we block at points *a* and *b*, as shown, we have removed the weight off of the box and strain off of the equalizer and transferred them to No. 1 and No. 3. Should we break the driving spring at No. 4 we simply block between both equalizers and the frame indicated at *c* and *d*.

In Fig. 3 we illustrate a broken driving brass on No. 2 and a broken equalizer on No. 3. Here in this case we must remove the broken equalizer over No. 3 and block on the top of driving box. We next raise the spring at *a* and block between the safety hanger and spring, per-

The Growth of the Locomotive.

BY ANGUS SINCLAIR.

(Continued from page 545, ante.)

RAILWAYS CEASE LOCOMOTIVE BUILDING.

During the first two decades of railroad operating in the United States there was a tendency among a few leading railroad companies to build their own locomotives, but that practice was gradually abandoned and the contract locomotive builders became the recognized authorities, not only for building, but also for designing the motive power. Great rivalry existed among them, principally as to which establishment could build the best engines, a form of emulation which militated very much in promoting the interests of their customers.

Baldwin, Norris, Eastwick & Harrison were the first builders of any consequence in the business. Gillingham & Winans had rented the Baltimore & Ohio shops, at Baltimore, and were building locomotives by contract, but most of their output went to the Baltimore & Ohio Railroad. The Locks and Canals Company, Lowell, Mass., had begun building locomotives in 1834, and were doing a small business, their output being close imitations of R. Stephenson & Co.'s "Planet" type of engine. The West Point Foundry Association, of New York, which did the first building of locomotives in the United States, had abandoned the business for what they considered more profitable work. William T. James was turning out an engine of extraordinary design occasionally, and various, almost forgotten concerns were building a locomotive that occupied their capacity the greater part of a year.

That was the condition of locomotive building in the United States in 1837, when Thomas Rogers, of Paterson, N. J., entered the business. His was one of the few establishments that weathered all the storms and financial disasters, which wrecked most of the concerns that attempted to establish the business of supplying railroad companies with locomotives.

THE FASCINATION OF LOCOMOTIVE BUILDING.

There seemed to be something very alluring about the business of locomotive building in early days. When Mr. Baldwin was wrestling to overcome the structural defects of his first engine, the Old Ironsides, he is said to have remarked that he would have nothing more to do with locomotive building, but the attractions of the business proved too strong for his resolution, and he returned to the work and was one of the few to make it a magnificent success. Many others put their hands vigorously to locomotive building, and have left no suc-

cessor to eulogize their labors, record their difficulties and perpetuate their memories.

THOMAS ROGERS.

Thomas Rogers was Connecticut born and learned the trade of house carpenter. In 1812, when twenty years old, he removed to Paterson, N. J., then a small village, but very prosperous with its in-



THOMAS ROGERS.

fant textile manufactures, whose products were greatly in demand owing to the war with Great Britain.

Like many other skilful carpenters, Mr. Rogers took up the work of pattern making, and prospered. Being industrious and of frugal habits he saved money and soon became a partner in a concern engaged in making looms, in

were urgently in demand. Some of the concerns building locomotives were provided with neither tools nor engineering ability for the work, and naturally very inferior engines were offered for sale. The leaders in railway enterprises realized this, and some of them kept urging Mr. Rogers to engage in the business of locomotive building. John B. Jervis and Horatio Allen took the lead in this kind of solicitation and they got others to second their efforts.

PATERSON A GOOD LOCATION FOR LOCOMOTIVE BUILDING.

Paterson was regarded as an ideal spot for manufacturing in those days, for the place was located below the high falls of the Passaic River, which provided excellent water power and a fine rolling country spread out from beneath the falls, suitable for the building of a city. It was within easy distance of New York and was likely to be well connected with railroads.

ROGERS BEGINS BUILDING LOCOMOTIVES.

An announcement appeared in the *American Railroad Journal*, December 24, 1835, that Rogers, Ketchum & Grosvenor were prepared to receive orders for locomotive engines and tenders, locomotive wheels, axles, springs, etc. They mentioned that the works being extensive and the number of hands employed being large, they were enabled to execute orders with promptness and dispatch.

THE SANDUSKY.

Their first engine, the "Sandusky,"



ROGERS LOCOMOTIVE WORKS IN 1837.

which his skill, shrewdness and energy helped to work up a very successful business. In 1832 he became the leading spirit in a new machine-making firm which was called Rogers, Ketchum & Grosvenor.

At that time railroad mileage was increasing very rapidly, and locomotives

Fig. 45. was not, however, finished until 1837. The engine had cylinders 11x16 inches placed under the smoke box transmitting the power to the cranked axle of a single pair of driving wheels which were placed in front of the fire box after the Norris plan. The front end was carried by a four wheel truck

with four 30 in. wheels. Outside frames were used, made of wood sheathed with iron. The ends of the driving axle protruded through the pedestal and carried the eccentrics and straps, which had rods

inside cylinders under the smoke box through a crank axle. The boiler was of the form favored by the builders, having a short, shallow wagon top surmounted by a man-hole and a dome well

was 4 feet 10 inches. The Legislature of Ohio passed a law afterward making the railroad gauge of the state the same as that of the Mad River & Lake Erie Railroad.

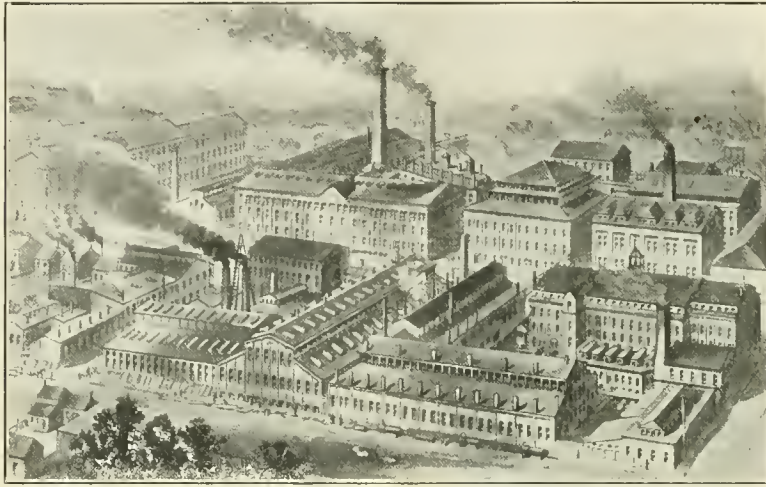

ROGERS LOCOMOTIVE WORKS, 1900.

that extended back and with drop hooks operated rocking shafts that were located under the footboard.

The boiler was peculiar, for that time in the United States, having been straight with a slight wagon top which was provided with a man-hole. There was a dome in the middle of the barrel.

The most peculiar feature about the engine, however, was the driving wheels, which had cast iron centers with hollow spokes, and the section of the wheels opposite the crank was made with sufficient extra weight to counterbalance the crank and connecting rod. From the first Mr. Rogers appeared to recognize the importance of counterbalancing the crank and its connections, but this necessity was not generally recognized until years after he led the way. It was really the most important improvement that had been effected on the locomotive with a single pair of drivers, although it did not originate with Rogers. Coleman, Sellers & Sons having used it three years previously.

The crank axle used by Rogers was peculiar, and was equivalent to the half crank used by Baldwin, one side of the web being set into the driving wheel, which made room for the crank to work at the side of the fire box. It was an ingenious way of getting around the Baldwin patent.

ENGLISH INFLUENCE ON EARLY ROGERS LOCOMOTIVES.

Two years before Rogers began building locomotives the Paterson & Hudson Railroad Company received from Robert Stephenson & Co. an engine which had the Jervis truck and a single pair of driving wheels in front of the fire box to which the power was transmitted from

forward on the barrel. There is no doubt that the Sandusky was made to closely imitate that engine.

THE SANDUSKY GOES TO OHIO.

About the time that the Sandusky was finished, Mr. J. H. James, of Urbana, O., president of the Mad River & Lake Erie Railroad, visited Paterson looking for a locomotive, and the Sandusky suited him. Mr. Rogers was opposed to selling and protested that the engine was built for the New Jersey Railroad and Transportation Company, but Mr. James would

FIRST RAILROAD IN OHIO.

The Mad River & Lake Erie Railroad Company, which transported the first locomotive west of the Allegheny Mountains, was chartered in 1832 to build a railroad over the shortest and most direct route between Lake Erie and the Ohio River. The route was followed by the French voyageurs in their trading intercourse between Canada and Louisiana.

The route of the line was distinctly specified and it was provided that the state should have the right to purchase the road after forty years from the time fixed for completion of the work. This was never done. The work of construction was pushed rapidly and the company was fairly prosperous until extensions were undertaken which led to financial complications. The road is now part of the Cleveland, Cincinnati, Chicago & St. Louis Railway.

ROGERS IMPROVES THE LOCOMOTIVE.

The first four engines built by Rogers closely resembled the Sandusky, but the fifth one, turned out in 1839, the "Batavia," Fig. 48, had a Bury hemispherical top boiler, the driving wheels were located behind it and the rocker shafts were near the middle of the frame, but still actuated by eccentrics secured on the outer ends of the driving axle. With the driving wheels behind the fire box

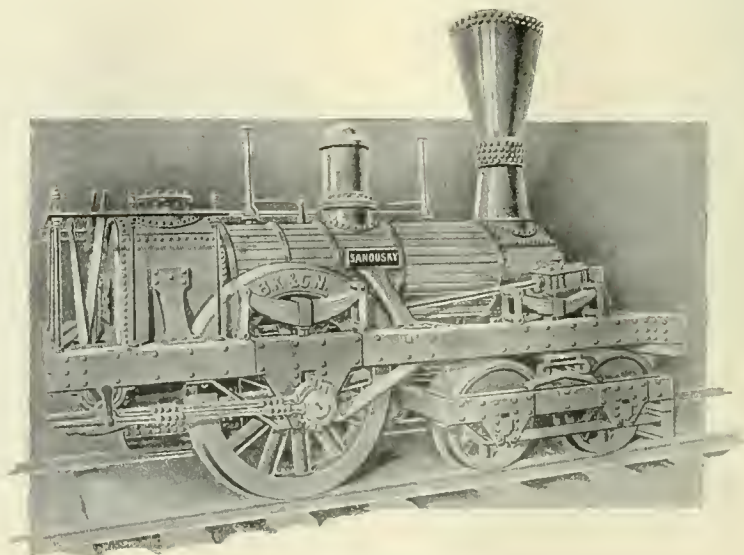

SANDUSKY. FIG. 47.

take no refusal, and being a very persistent man he concluded by shipping the engine by canal and lake to Sandusky. Track laying had not begun when the engine reached its destination, so they built the road to suit its gauge, which

it was discovered that this engine was deficient in adhesion and was given to excessive slipping. To remedy this defect an arrangement was provided for transferring part of the weight of the tender upon the drivers.

TRACTION INCREASERS.

Traction increasers to perform the same functions as that invented by Rogers were applied to a considerable extent by the early locomotive builders. En-

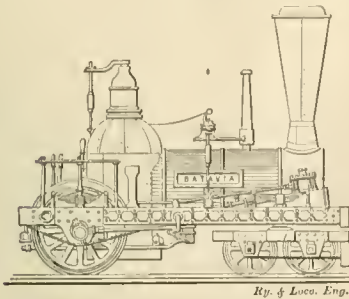

BATAVIA. FIG. 48.

gines with a single pair of driving wheels were naturally slippery and a variety of devices were invented to throw all the weight available upon them.

The first locomotives built by Rogers had not long been in service before the maker became convinced that inside connected engines with the annoying crank axle were inferior in many respects to those with outside cylinders and connections. They were more expensive to build and more difficult to maintain and repair.

The British locomotive builders preferred inside connected engines, because they were reputed to run steadier than those that were outside connected, but Mr. Rogers came to believe that the steadiness was due to the want of suitable counter-balancing, and that when this was properly done, outside connected engines would run with as little oscillation as those with cranked axles.

OUTSIDE CONNECTED ENGINES POPULAR.

To aid his theories in favor of outside connected locomotives, Mr. Rogers had many object lessons at hand that could not be ignored. The most popular locomotives at work in 1840 were built by William Norris and had outside cylinders. Those turned out of the Eastwick & Harrison works all had outside cylinders, and

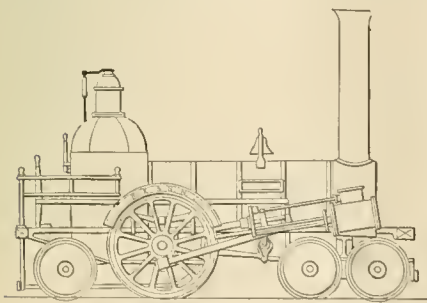

STOCKBRIDGE. FIG. 49.

most of the minor builders out of New England followed the same practice. The outside connected engine was much more convenient to get at and to repair than the other kind, and this made them popu-

lar with engineers, which counted a great deal in maintaining the popularity of engines.

ADOPTS OUTSIDE CYLINDERS.

In 1842 Rogers began building outside connected engines, and he very seldom afterward departed from that practice. His first outside connected engine was the "Stockbridge," Fig. 49, which had a single pair of driving wheels in front of the fire box, a four-wheel truck under the smoke box, and one pair of carrying wheels under the footboard.

It was generally acknowledged that American six-wheel engines (single pair of drivers and four-wheel truck) were deficient in adhesion, but both Baldwin and Rogers displayed curious reluctance

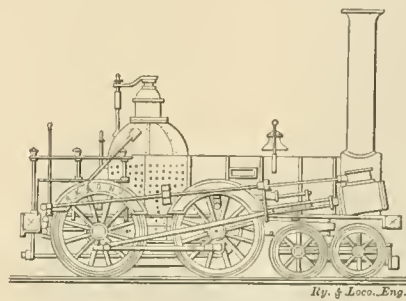

FIG. 50.

to employ coupled driving wheels. Rogers' "Stockbridge," with the pair of carrying wheels brought this difficulty to a crisis so far as the builder was concerned, for the engine was remarkably

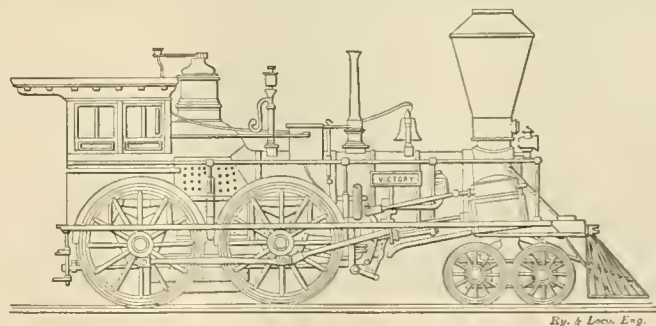

FIG. 51.

slippery, and he determined to adopt coupled drivers.

The first engine (Fig. 50) built with coupled drivers was peculiar in some respects. The eccentrics were on the back axle and operated a rocker behind the back drivers, which entailed the use of a tremendously long rod to reach the valve stem. The engine was remarkable in being the first example of the use of equalizing beams between the driving wheels and truck.

Their first American type of locomotive was built in 1844, and the Rogers Locomotive Works had entered upon the direct line of progress, that by enlargement and adjustment of proportions produced the modern locomotive, with

its great variety of types. All the locomotive building works that survived the third decade of railroad operating made progress similar to Rogers and built types of engines that differed very little from those turned out of rival shops.

The head of the Rogers works was very progressive and took the lead in introducing improvements that others regarded with distrust.

INTRODUCES THE LINK MOTION.

The shifting link valve motion was invented by William T. James in 1832, and applied to a locomotive built for the Baltimore & Ohio Railroad. The boiler of the engine exploded and the disaster destroyed the mechanism so that no proper opportunity was given to demonstrate the value of the link motion, and James did not appear to be greatly impressed with its merits, for in a locomotive which he built a few years later for the Harlem road, he employed a revolving pipe inside of the dry pipe to regulate admission of steam to the cylinders.

Ten years after James had tried the shifting link motion, it was reinvented by William Howe, a mechanic in the employ of Robert Stephenson & Company, Newcastle, and applied to a locomotive under construction for the North Midland Railway. The motion gained popularity very rapidly in Great Britain and was promptly adopted by all the locomotive builders there. Its praises were eloquently expressed in various publications, but American builders would have

none of it until in 1849 Rogers applied it to an engine called the "Victory" (Fig. 51). He soon became a warm advocate of that form of valve motion and his influence was a potent factor in bringing it into general use.

WILLIAM SWINBURNE.

In connection with the successful introduction of locomotive building by Rogers, Ketchum & Grosvenor, one man, whose name is seldom heard in the annals of locomotive building, deserves a great deal of credit. This was William Swinburne, who had charge of the shops when the "Sandusky" was built. Mr. Swinburne was one of those versatile men whose services are always invaluable.

able when the introduction of new operations has to be carried out and who so seldom receive proper credit for the work they have done. Mr. Swinburne was chief draftsman for the firm, principal pattern maker, superintendent of construction and foreman of blacksmith and machine shop. He was the only foreman in the place. The shop where the first locomotives were built was 40 by 100 ft., two stories in height. From thirty to forty men were employed, and upon Mr. Swinburne rested the responsibility of keeping the men at work and showing them how to perform new operations.

About the time the firm decided to begin locomotive building Mr. Rogers engaged an Englishman named Hodge, who had been recommended to him as a good mechanical draftsman. This man was employed to make the drawings for the Sandusky, and his incompetency almost put a premature end to the business

An Electric Traveling Gantry Crane.

The up-to-date car and machine shops of the Central Railroad of New Jersey, situated at Elizabethport, N. J., of which Mr. G. L. Van Dorn is superintendent, has lately added to its already fine equipment a most useful outdoor appliance in the shape of a six-ton electric traveling gantry crane.

This machine was supplied by Messrs. Manning, Maxwell & Moore, of New York. It is 20 ft. 9 $\frac{1}{4}$ ins. in the clear, and has a span of 74 ft. At present its travel is a little over 112 ft., as it covers the ground in front of the machine shop, but it is intended to make it operate also in front of the blacksmith shop and to cover the intervening space. This will add 144 ft. to its travel, making a total area of 74 x 256 ft., every point in which can be reached.

The electricity for its operation is supplied from the shop power house, and wires connect with three motors. The

turns hard, time-consuming work into play. The slow but familiar process of rolling all the wheels off a track in order to reach the last pair and then rolling them all back again, is a thing of the past at the Elizabethport shops of the C. R. R. of N. J.

A Fireless Steam Locomotive.

From Germany comes news of a locomotive worked by steam and yet independent of fire of its own. The engine has just been completed at the Hohenzollern works at Dusseldorf, and is one of a type designed for shunting in explosive factories. Instead of carrying fire in its own boiler it is filled with steam from stationary boilers, and when so charged is capable of several hours' work. The first warming up occupies half an hour, and subsequent recharging can be done in a quarter of an hour. The apparatus is so simple that an unskilled workman is able to look after it. The absence of fire in a place where dynamite or gunpowder is being handled is the reason for the invention of this type of engine, which is known to engineers as the Lamm Franc system. The working of it is said to be only half as expensive as that of an ordinary locomotive.—*New York Commercial Advertiser*.

Dangers of Early Railroad Locating.

The people, who ride in ease and comfort over mountains and through dreary deserts during the transcontinental journey, little realize the dangers and hardships endured by the pioneers who first laid out and built the railroad. Life on an engineering survey was quite as exciting and dangerous as a soldier's life on a hard-fought campaign. Accounts of the experiences of engineers on the Atlantic and Pacific surveys would make a thrilling story, as interesting as anything ever written on human enterprise and endurance.

As late as June, 1880, the experience of an engineering party on the Texas & Pacific Railroad reads like a page of romance. A surveying party, after days of extreme suffering from thirst in the White Sand Hills district, arrived at the Pecos river after a series of experiences seldom paralleled. Wagons were abandoned at different intervals of forty miles along the trail and the greater part of the stock had to be abandoned, but some of the most energetic and vigorous men pushed along for the river, and their courage and enterprise were the means of saving the party. As soon as they reached the water and assuaged their own thirst they proceeded without loss of time with a supply of water for others who had fallen by the wayside and were dying from thirst. After very great difficulty the whole of the party were brought in. Several of the men were crazed with thirst and had entirely

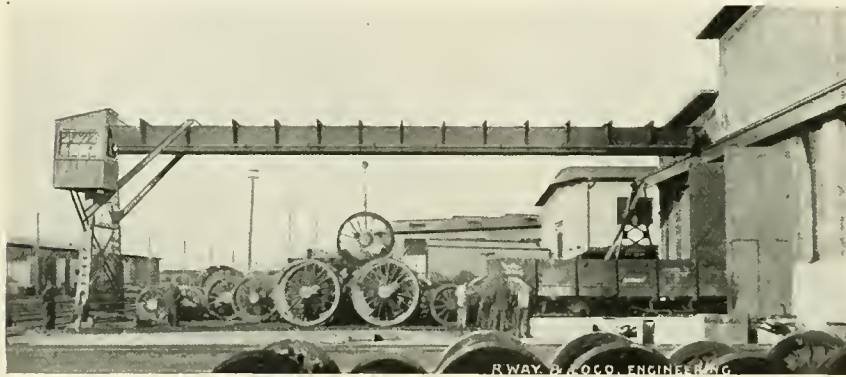

SIX-TON GANTRY CRANE, ELIZABETHPORT SHOPS OF THE C. R. R. OF N. J.

of building locomotives. In making the drawings of the boiler, he blundered so badly that the fire box would not go into the shell. Mr. Rogers was very much discouraged and disgusted, and after discharging the draftsman, he said: "Put away the whole business; we are done with it." Mr. Swinburne, however, expressed the opinion that he could overcome the blunder, and after a time, he was given permission to try. He was advised by Mr. Rogers to go and carefully examine the English locomotive, "McNeil," then running into Paterson. He did so, and after studying the engine carefully, he made the drawings for the new fire box, which proved satisfactory.

William Swinburne was born at Brooklyn, N. Y., in 1805 and learned the carpenter's trade at Matteawan. In 1833 he went to Paterson and began work in a millwright shop. When the Rogers, Ketchum & Grosvenor firm was established Swinburne went to work for them as foreman and he continued in their employ until about 1845. He afterward engaged in the work of building locomotives for himself.

(To be continued.)

main drive motor, used to move the crane along the track, is placed at the end farthest from the shop wall, and adjoining the traverse table pit. At this end the crane rests on two legs which have a spread of 16 ft., while the other end is carried on brackets above the shop doors. The crane, therefore, resembles the letter "L" turned over on one side, thus Γ . The crane motor is a 12K machine, Crocker & Wheeler, 16 h.p., running at the rate of 750 revolutions per minute, 240 volts, and giving a speed of 100 feet in a minute.

The hoist motor is a 7 h.p. 240-volt machine running at 640 revolutions per minute, and lifting at the rate of 20 ft. per minute. The trolley drive motor is a 2 $\frac{1}{2}$ K machine, 3 h.p., running at 640 revolutions per minute under 240 volts pressure. The transverse movement of the trolley is at the rate of 100 feet per minute.

Our illustration, which was made from a photograph taken by our own artist, shows the crane lifting a large pair of driving wheels. The ease and rapidity with which all sorts of material can be picked up and carried away by this crane

stripped themselves of all wearing apparel. Three of them were found within one hundred yards of the Pecos river, where they were drinking the blood of an animal they had killed. Some of the men were totally blind, and on arriving at the river plunged into the water head foremost. Had it not been for the bravery and experience of those who took the lead in working out the rescue, nearly all of the party would have died in the sand.

The Mexican National Railroad Company have recently changed the gauge of their line from narrow to the standard, 4 ft. 8½ ins. The work was done without any interruption of traffic, and the time occupied in completing it has been about two years. In standardizing the road, grades and curves were corrected as far as possible. A new road has been built between Gonzalez and the City of Mexico. This new line will compete with the Mexican Central for business between those two cities. About 100,000 tons of rails were used, 75,000 tons coming from England and 25,000 tons from Belgium. The contract for the 25,000 tons had been awarded in the United States, but when the time for delivery came the American concern being rushed with home orders, were compelled to buy in Belgium at a loss in order to deliver to the Mexican National. The equipment lately purchased by this road was fifteen passenger 10-wheel engines, 55 consolidations, 40 new passenger coaches and 1,700 new freight cars.

In making a comparison of the capacity of tanks on locomotive tenders, both American and foreign, it is necessary to remember that the British or Imperial gallon differs from the United States standard gallon, the Imperial being the larger of the two, it contains 277.274 cubic inches. The United States gallon is 83 1-3 per cent., or 5-6 of the Imperial. The liquid measure in use in the United States derives its gallon from the old English wine gallon, and contains 231 cubic inches, and is capable of holding 8.3388 lbs. of pure distilled water at a temperature of 39.1° F; or 8 1-3 lbs. at a temperature of 62° F. The temperature of 39.1° F or 4° C is called the temperature for the maximum density of water. Water increases in volume whether it be heated above, or cooled below that temperature, and herein lies the explanation of why ice floats.

The bound volume of RAILWAY AND LOCOMOTIVE ENGINEERING for 1903 is now ready for delivery. It forms a very useful and interesting book that is highly suitable as a present to a friend who likes to read about locomotives and other railway machinery. Will be found particularly useful for students. It costs only \$3.00.

Signals and Signaling.

BY GEORGE S. HODGINS.

(Continued from page 561, ante.)

BREAKS IN MAIN LINE TRACK.

On any railroad, where electric automatic block signals are used, a very useful feature presents itself when we come to consider the signaling of so simple a permanent way arrangement as a crossover track between the two lines of a double-track road. We have already pointed out that if a rail becomes broken the "home" and "distant" signals at the entrance of the block containing the broken rail at once assume the "danger" and the "caution" position and the "caution" signal arm is raised at the entrance of the block next behind. This feature, or we may almost say this principle, operates when a switch is opened anywhere in a block, but the opening of a switch leading to a crossover track blocks both lines.

In order to understand how this is done, it will be necessary to briefly consider what is called the track circuit. The signals governing a block stand at the entrance of that block, and the battery operating the track circuit is situated at the other end. The battery is usually composed of two or more cells, arranged in parallel and placed in a box, sunk in the earth below the frost line. Wires leading from each pole of this battery are fastened one to each line of rails forming one track. The ends of the rails in each line are bonded together with either galvanized or copper wire so as to insure good electrical connection throughout, and the rails at the end of the block are insulated from those of the next block. This insulation is effected by having blocks of wood interposed between rails and fish plates and an "end post" made of fiber, the exact section of a rail is interposed between the rails forming the beginning and the end of each block.

Current flows, say, from the positive pole of the battery into, we will say, the fireman's rail. It goes along that rail to the other end of the block where it passes through a wire to a relay,

through the relay and on by a short wire to the engineer's rail and along that rail back to the battery. There is thus a complete electric circuit established, and this is called the track circuit. The resistance in the rail is exceedingly small, and as the resistance of the battery and in the relay is only a little more, the leakage of current across from one rail to the other, even in wet weather, is very slight. When everything is in working order current of low voltage flowing through



ABOUT TO ENTER BLOCK—"ALL CLEAR."

the track circuit relay, keeps it energized. The contact points of this relay control another and distinct electric current, which operates the signals.

When a train enters a block, wheels and axles unite the rails and current readily leaps through them, as the resistance they offer to its passage is less than that of the relay. The current being thus short circuited, the relay is practically cut out and its armature, which was only held up while current flowed, drops, and in so doing breaks the signal circuit, and the heavily counter-weighted semaphore arms on the post above, rise to the "danger" and the "caution" positions.

The accidental breaking of a rail, or the exhaustion of the battery will deprive this relay of current and the same stop indication will be given. The track circuit is so arranged that the opening of a switch anywhere in the block interrupts the flow of current, and the stop indication is at once given.

A still further refinement in the art

As a consequence of the "home" signal on each line going to "danger" when either or both of the crossover switches are thrown, it follows that the "distant" signals on the posts of the block next behind in both directions assume the "caution" position. The opening of the "down" crossover switch, therefore, moves six semaphore

"down" line crossover switch at *d.s.* closed as soon as the train entered block B, both switch indicators would show "danger." This prevents the possible simultaneous action by engine and man at switch, causing confusion, as signal C yet remains to stop an oncoming train, if such simultaneous action had taken place.

The feature of the switch signal indicator just alluded to, which adds to the safety of train movement, is that if both crossover switches were set so as to make each main line a continuous track the presence of a train in block B, in the diagram, would at once set both switch indicators at "danger" because the opening of either one of these switches destroys the absolute safety of train movement in both tracks.

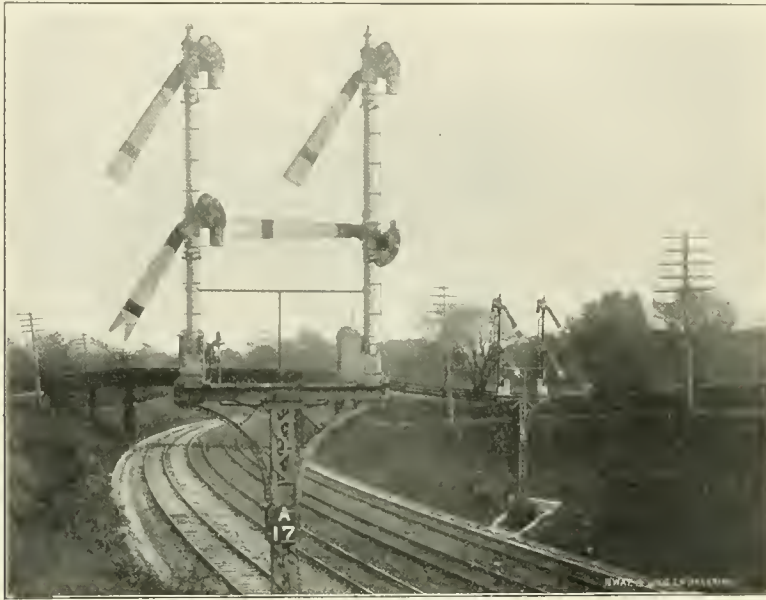

UNION SWITCH AND SIGNAL COMPANY'S INSTALLATION ON THE PENNSYLVANIA.

of safe signaling is practiced where a crossover track is used, or where a siding lies anywhere in a block. In spacing blocks, the signal superintendent or signal engineer usually arranges for a block to begin on each track about 600 feet or more from the crossover switch. These signals are usually of the familiar two-arm semaphore type. The crossover track switches are arranged so that only trailing points will be presented to an oncoming train. If now the crossover switch on the "down" line be opened, the "home" and "distant" on the "down" main line will give the stop indication. The opening of the "down" crossover switch menaces the safety of

arms and operated both switch indicators. This is eight signals in all, as shown in the diagram. This operation, therefore, blocked both main lines in the neighborhood of the open switch, and it warned both lines each with a "caution" a full block away. The opening of either or both switches causes the signals to move as described.

Referring to the diagram, the leading wheels of the engine have just entered block A, and the signals on that post give the stop indication to any train following. The down crossover switch being open, the switch indicator marked *d.s.* suitably indicates the fact and the "home" and the "distant" at C stand at "danger" and "caution" respectively.



HALL AUTOMATIC SWITCH INDICATOR —LATEST TYPE.

The switch indicator to which reference has just been made consists of a circular cast-iron box standing on a post of convenient height. It usually has a small circular opening in the face, turned toward the switch stand. It is intended solely for information of a man intending to open the switch and is too small to be seen by the engine-men. When the main line near which it stands is clear, the switch indicator is "clear" also. When, however, a train enters the block next behind, a red disk swings into the little circular opening of the indicator and remains there until the block in which the switch is situated has been vacated by the train. The latest form of this signal made by the Union Switch & Signal Co. and the Hall Signal Co., show a miniature semaphore with one arm. It is evident,

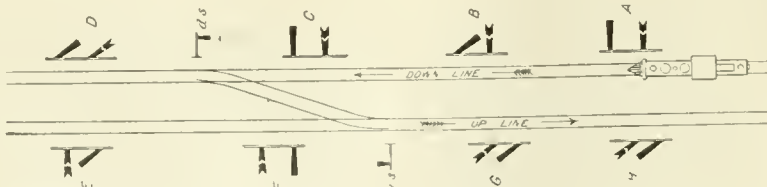

POSITION OF SIGNALS WITH "DOWN" CROSSOVER SWITCH OPEN.

the "up" main line even before the "up" main line crossover switch is thrown. An electrical instrument, operated by the down crossover switch rails, shunts current in the track circuit of the "up" line, and the "home" and "distant" there also give the stop indication.

As it is possible, with this switch open, to foul the "up" line though that line may be continuous, the "home" and "distant" at F give the stop indication, while the "distant" at E shows "caution." The other signals, where the blocks are unoccupied or where passage is safe stand at "all clear." With the

therefore, that a switch cannot be opened without warning both main lines, and also the approach of a train is made to inform anyone seeking to open a main-line switch as to whether he may do so with safety or not.

In operating a siding switch within a block, a modification of the same prin-

the clearance point, because the train on the siding is then in the position which is described in the language of the road as being "in to clear."

THE BLACK AUTOMATIC MECHANICAL SIGNAL.

A simple form of automatic block signal operated by the moving train,

houses and buildings close by completely obstruct the view.

The signal consists of an upright circular iron post with two flat vertical plates at the top which resemble in outline the form of the semaphore arm. When the arm is hidden or partly hidden between these plates, it is in the vertical position and with a white light gives the "all clear" indication. When the arm is horizontal a square red spectacle glass is swung in front of the signal lamp and gives the "danger" indication.

The movement of the signal is produced by the wheels of the first vehicle passing over a trip which is then pushed down. The trip consists of a pair of inclined bars which make an exceedingly obtuse angle with each other where they meet. These are set close to the outside edge of the track and project about one inch above the top of the rail at their joint. A wheel moving along the track encounters the inclined bars and bears upon them with the outer edge of its wide tread and as it proceeds the bars are gradually pushed down. In fact, the kink which the joint of these two bars make is gradually rolled out and the bars lie flat, the joint having been pushed down through a distance of one inch. This movement is increased by the long arm of a bell crank while a light line of pipe on rollers carries the motion thus produced to the signal.

The pipe line terminates in a broad, flat plate, which slides between guides and in this plate there is cut a slot something like the outline of an old-



SWITCH STAND AND TARGET WITH SWITCH INDICATOR BESIDE IT. TRACK INSULATION SHOWN AT END OF BLOCK.

ciple is brought into play. The opening of the switch at once gives the "stop" with both arms horizontal on the nearby signal post, and the "caution" on the post of the block next behind, which shows the break in the continuity of the one main line, and warns and halts a train in due time.

One of the dangers in using a siding is that until the train is well in on the siding and the switch closed, the main line is practically occupied. It is possible to close the switch and yet have the last car of the train overhang the main line. The point where a car partly in on the siding would just be struck by a passing main-line train is the "fouling point" of the tracks, and all possible danger is avoided by carrying the track circuit up along the siding rails a suitable distance beyond the fouling point, so that even if the switch be closed, the wheels of a car standing within the prohibited distance will still short circuit the current and hold all the signals as they were when the switch was open. The point where the circuit in the siding rails terminates is sometimes somewhat incorrectly spoken of as the fouling point. It is really the clearance point and there is always a safe margin between it and the actual point of possible collision. The rear car of a train drawn anywhere past the actual fouling point is safe, but the signals only indicate that the main line is unobstructed when the car is beyond

has been used for a number of years on the Manhattan (Elevated) division of the Interborough Rapid Transit System in New York. The signal called after its inventor, the Black automatic semaphore, is used for the pur-



SIGNALS GOVERNING RIGHT-HAND TRACK, PROTECTING REAR OF TRAIN WHICH HAS JUST PASSED.

pose of preserving a space interval between trains on the short stretches of track on cross streets between the curves to the long north and south lines through the city. The curves being around street corners are necessarily exceedingly sharp, and the

fashioned stove-lid lifter. In this slot a pin fits, fastened to two flat bars which move above and below the broad, flat plate, and at right angles to its line of motion. The two flat plates terminate in a bar which operates a bell crank, and thus moves the signal arm.

When the wheels of an advancing train press down the trip near the signal the broad, flat plate is made to slide and the inclined slot with the parallel ends carries the pin of the signal rod over toward the signal and raises its arm to "danger." The motion given to the broad, flat plate is further utilized to operate a light line of pipe on rollers which runs to a point sufficiently far from the signal to secure the required space interval between trains. Here another and similar trip is arranged, and this second trip is raised up in the center by the flattening of the first trip. The second trip is therefore in a position to have its kink rolled out when the train comes along. The rolling out of the kink in trip number two lowers the signal and kinks up trip number one.

The train as it proceeds always encounters two trips which it presses down, first one and then the other, but the depression of the first sets the signal at "danger" behind the train and raises the second trip further up the track. The depression of second trip gives the "all clear" indication and sets the trip, close to the signal, up in position to be again flattened out. Thus a train sets the signal behind it at "danger" and itself lowers it when at a safe operating distance from the signal.

(To be continued.)

Some years ago a good looking young Irish fellow who had at length attained to the dignity of brakeman on a train of "varnished cars" on the Michigan Central, was instructed by his conductor as to how he should assist in calling out the names of stations. The conductor explained that it was necessary to speak very distinctly, and said that when he (the con.) opened the door and called out the name of the station, the brakeman was also to open his door and whatever the name of the station happened to be, after the conductor had called it, the brakeman was to say the same at his end of the car. When the train was nearing a thriving city in Michigan, the conductor opened the door and called out "Jackson—Jackson." The brakeman promptly swung open the door at the other end of the car and shouted: "Same at my end—Same at my end."

Our spurts of train speed have not increased much since 1882. In that year an engine belonging to the Pennsylvania Railroad pulled a train from Philadelphia to New York, 90 miles, in 80 minutes.

Every failure teaches a man something, if he will learn.—*Little Dorrit.*

Paper Wheels.

A recent article in RAILWAY AND LOCOMOTIVE ENGINEERING on Resilient Wheel Centers, has brought us several inquiries about Allen paper wheels, and we find that there is considerable misapprehension as to what paper wheels really are, one correspondent thinking that the whole wheel is made of paper. We have heard of others who fell into this error, so we will explain how the paper wheel is made.

The paper car wheel was the invention of Richard N. Allen, a locomotive engineer, afterward for a time master mechanic of the Cleveland & Toledo Railroad. He spent the savings of many years in having the first set of paper wheel centers made, and the work was done in Brandon, Vt., in 1869. His invention was the subject of numerous small witticisms, and it was after much persistent effort that he received permission to try them under a wood supply car on the Central Vermont Railroad, where they were tested for six months.

Allen was an enthusiast about his wheel, and he convinced George M. Pullman that it was a valuable invention, with the result that in 1871 the Pullman Car Company gave an order for 100 wheels. These gave so much satisfaction that a strong company was formed for their manufacture, and large works were established for the purpose at Pullman, Ill., and at Hudson, N. Y. One of the first set of paper wheels applied to a Pullman sleeping car made 300,000 miles before the tires, $2\frac{3}{8}$ ins. thick, were worn out. The life of the wheel center has not yet been ascertained.

The material of the paper wheel is a calendared rye straw board or thick paper made specially for the purpose at the company's paper mills. This is sent to the works in various sizes suitable for the dimensions of the wheel center to be made. The first operation is for two men standing beside a pile of the boards to brush over each sheet a coating of flour paste, until a dozen are pasted into a layer. A third man transfers this layer to a hydraulic press, where a pressure of 500 tons or more is applied. After solidifying under this pressure for two hours, the 12-sheet layers are kept in a drying room heated to a temperature of 120 degrees Fah. Several of these layers are in turn pasted together, pressed and given another drying. This is kept up until a circular block is formed containing from 120 to 160 sheets, varying from $4\frac{1}{2}$ to $5\frac{1}{2}$ inches in thickness, and as compact as seasoned hickory.

The blocks are then turned in a lathe slightly larger than the tire, and the hole is bored for the cast iron center. In turning the paper blocks make a shaving that resembles strips of leather. The center and the tire are forced on under a powerful hydraulic press.

The average life of the tire of a paper wheel is about 300,000 miles. That represents about $1\frac{1}{4}$ -in. wear. The centers do not seem to be affected by service, and they are always good for renewal of tires unless some accident happens to them.

Cheating by an Endless Chain.

Some years ago we heard a great deal about the "endless chain" in financial operations which related to a practice the government was following in selling bonds to purchase gold which was immediately hoarded as it reached the banks and was used again to buy more bonds. That was a case of individuals trying to beat the people.

In the mechanical world we frequently find people trying to cheat nature by means of an endless chain. An examination of the patent records reveals many curious, amusing and wonderful attempts made to perform impossibilities by means of the endless chain. We commented some months ago on an invention designed to gasify the hydrogen in water and use the gas for fuel. Water is formed by two gases that die in the combination. An attempt to separate them to obtain fuel is working on an endless chain that will not move.

Our attention was called lately to patents connected with boiler construction through an inventor showing us the model of an improvement he had designed for obtaining more of the heat out of the fuel gases. The man had heard of the advantages obtained in metallurgical processes from the use of a hot blast, and he conceived that what was good for melting iron would not be bad for making steam. He proposed obtaining a hot blast for the locomotive simply by carrying the hot gases from the smoke-stack into the ash pan. There was to be no end of heat saving from the process. It was new information to this improver of the locomotive boiler when we tried to explain that the gases passing out through the smoke-stack were dead fumes that had no more power to sustain combustion than the breath passing from the lungs was capable of sustaining life if drawn separately back again.

We are aware that men who knew nothing of nature's laws had previously proposed using the hot dead gases to sustain the living fire, but we are surprised on searching through the patent records to find how often methods to be operated on that principle had been covered by letters patent. A hot blast, or the supply of heated air to sustain combustion in a steam boiler would no doubt help to maintain a high furnace temperature, a very great aid to economy, but air is so hard to heat, and absorbs heat so slowly from any hot surface it passes over, that there is no hope of ever applying its benefits successfully to locomotives.

General Correspondence.

Making the Best of It.

At the N. Y., N. H. & H. roundhouse, in East Hartford, Conn., the foreman, with limited appliances at his command, conceived the idea of arranging one of the stalls so that when occasion arose to remove a pony truck wheel, the same could be done without removing the pilot, as had previously been the case.

Beginning at the wall he lowered the track 10 ins. for a distance of 15 ft. and bent one end of the rail at an angle of 45 degrees to connect with the other. After removing the binders on an engine truck the engine is moved up to the depression and the wheels pass down the incline and past the pilot. Instead of raising the front end of a Vaucain four-cylinder compound with jacks in order to do certain work to the cylinder or valves that would otherwise interfere with the truck wheels, the same methods are pursued. Although the arrangement is very simple, it has saved them much time and labor.

RAMBLER.

Care and Handling of the Compound.

An interesting as well as instructive report on the care and handling of the compound from the Traveling Engineers' Convention, which was published in RAILWAY AND LOCOMOTIVE ENGINEERING, of October, no doubt, was read and appreciated by the thousands of engineers and firemen who are readers of your valuable journal.

The compound is new among us and has been met with disfavor by a majority of engineers as well as some superintendents of motive power. It has reminded me of a man down in the world without a friend, his good qualities are hidden, while his poor ones are magnified and shown in every particular. We must acknowledge the compound of the past has had its weak points and its failures, which are being remedied and improved as they are discovered by superintendents of motive power as well as the builders, and no doubt we will find the compound of 1904 a superior engine to the one of 1903. Engineers are becoming more familiar with the care and handling of the compound than they were a few years ago, and as the engines become more numerous they will come more in favor with everyone.

It must be acknowledged by everyone that an engineer who has been running a ten-wheel engine for years, riding like a Pullman and without a click or jar in her,

has to give her up and take a compound, it is but natural for him to make a kick. In my experience, I find if an engineer will keep his wedges set up he will find a better riding engine; keep the forward and back end of his main rod brasses reduced and keyed up, his guides closed and pistons in line, he will not be annoyed by them pounding as much as some of them do.

If some of the men that have had experience and made a study of the compound would find time to impart their knowledge through the columns of RAILWAY AND LOCOMOTIVE ENGINEERING, their efforts would be appreciated by engineers and it would be a benefit to railway companies which have them in their service.

Colorado City.

J. M. C.

The Allfree Valve Gear.

I have read with a great deal of interest and profit your able editorial in the November issue commenting on the paper presented by Mr. Ira C. Hubbell at the last meeting of the New York Railroad Club.

The editorial, taken in connection with Mr. Sinclair's remarks made during the discussion of the paper, leads me to believe that you are not fully conversant with the details of the valve gear used by Mr. Hubbell, and by the use of which he was able to secure the practically perfect indicator cards he presented with his paper. I take this view of your position from that portion of your editorial in which you make specific reference to the Link Motion. It would appear to one reading this editorial that the Allfree Valve Gear was a substitute for the Link Motion. This, I do not understand to be the case, as the Allfree Valve Gear is a very simple mechanical movement that is added to and used in connection with the Link Motion; it is interposed between the rocker arm and valve stem connections of the usual valve gear now used on all our present day locomotives.

I heartily agree with your trite statement in your editorial where you say: "The diagram ought to point the way to real progress and act as a guide to improvement."

It strikes me very forcefully that Messrs. Hubbell and Allfree have followed this direction from the very beginning, inasmuch as they have made their improvements for the correct distribution of steam not only in the valve gear, but in the cylinder itself, and the combination of the two appears to me to give

almost ideal conditions for an every day realization of the steam economy we have been so long looking for in locomotive practice. I have personal knowledge of some five or six locomotives to which this system of steam distribution has been applied in its entirety, and the results so far have been extremely gratifying. The actual results being obtained are proving that the claims and assertions made by Mr. Hubbell for his System of Steam Distribution are being borne out in practice.

W. C. SMECHENG.

Progress.

It has been well said that progress is based upon principle, not policy; it moves forward, never backward, always toward the right and against the wrong; it does not necessarily mean peace, but will involve conflict when only that will answer. It is the survival of the fittest, not so much in man's power over nature, but through the power of principle in his control of self and his influence over his fellows. Ignorance or selfishness will antagonize and may temporarily impede the triumph of this fundamental truth, but ultimately it must be recognized that true progress means a broad unity of all great interests and activities and that purely individual or selfish aggrandizement has no part in the plan of human progress.

A proper recognition of this, in identification with and in judging as to the merits of all great activities, makes their real interest, as well as that of society at large, the same, simply because principle must ever be the underlying foundation of all real advancement, and therefore, no activity, individual or collective, can ever attain distinction in the world's progress unless in harmony with this law.

Progress means quicker movement. Great undertakings require great preparation and equipment, not only in ability, knowledge and experience, but in confidence and courage to promptly apply them. Large equipment and great opportunity bring increased responsibility. Where one life was touched a century ago, a thousand, yes, many thousands, are affected to-day. Never truer were the words of Carlyle: "The race of life has become intense. The runners are treading upon each other's heels. Woe be to him who stops to tie his shoestrings." As Wendell Phillips put it: "To be as good as our fathers we must be better." And there is no escape

from individual responsibility, which necessarily increases in proportion to that of the whole. As Disraeli said: "We put too much faith in systems and look too little to men." Individual responsibility cannot be hidden behind machinery, toward which there is some tendency in our times. Machinery is essential. Its use has revolutionized the world's methods, but when it gets so ponderous as to cover up individuality and become an end, instead of a means, it is an obstacle rather than a help. There is an old Italian proverb which says: "The work proves the workman." This principle has been true in all the ages of the world and is true to-day as a standard by which all work, collective and individual, must be judged, and no activity or interest can expect to have any part in real

the outside with steel plates. It is closed in on all sides, but there is an opening at the back through which the fireman reaches the coal, which, as used, works down to a tender deck plate conveniently placed. The tank holds 4,756 gallons of water and 6 tons of coal can be carried.

Contrary to the usual Swedish practice, these engines are equipped with headlights. This innovation is a useful one, as the railway line is not enclosed between fences for a long way north of the arctic circle, where nearly the whole winter is one continuous night.

Great care has been taken with the boiler head fittings. There are two gauge glasses with automatic cut off and protectors of heavy glass. Two double de Simons sight-feed lubricators oil the piston and valve rods, cylinders and valves

properly in many places. The builder of this type of engine had to go deep into many ways of thinking to get it to its present high standard of efficiency. Of course, with the slide valve engine, as all parts increased in size, the steam pressure would also increase. Under these circumstances, the only thing to do was, if possible, apply valves which would be almost a perfect balance; it was found that the piston valve would meet the requirements. It was installed, and is giving entire satisfaction, provided, of course, that it is handled in the right way. With the inside admission piston valve it was necessary to arrange for the relief of compression in the cylinders, and introduce a means of safety for the protection of cylinder heads from being knocked out by water getting into the

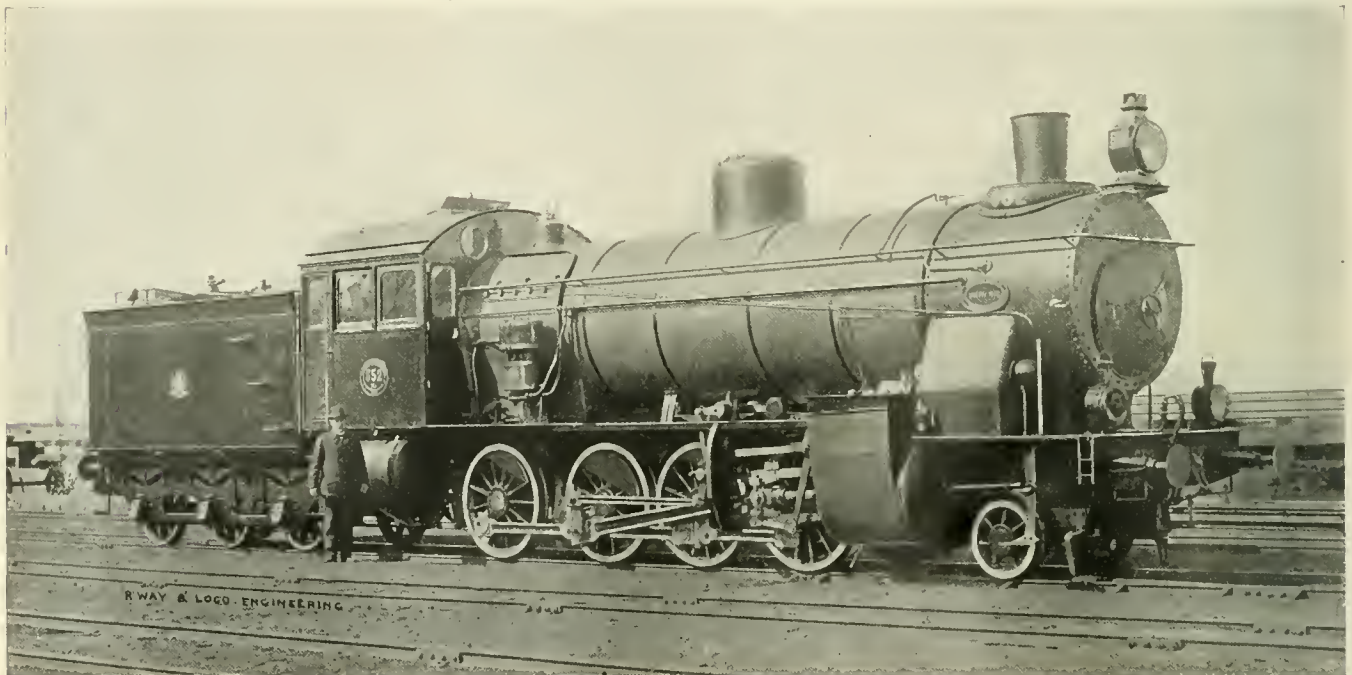

MELLIN TWO CYLINDER COMPOUND ON THE SWEDISH STATE RAILWAYS.

progress unless willing to be judged by that standard. B. D. CALDWELL,
At New York Railroad Club.

Heavy Locomotive on the Swedish State Railways.

The engine illustrated is a Mellin two-cylinder compound, the reducing and intercepting valves are contained in a box over the front foot plate ahead of the low-pressure cylinder on the right side of the engine. Hensinger Von Waldegg's valve gear is employed, and the cut off is regulated by screw-reversing gear.

The engine and tender are equipped with the New York air brake, having different braking power on loaded and empty trains. The duplex air pump may be seen on the running board on the right side.

The cab is made of wood, covered on

using the Malmros oiling device. The boiler is fed by two Gresham and Craven No. 10 injectors.

Some of the principal dimensions are as follows: Cylinders, $21\frac{1}{8}$ and $32 \times 25\frac{1}{4}$ ins; diameter of driving wheels, $51\frac{3}{8}$ ins.; wheel base, engine and tender, 45 ft. $1\frac{3}{8}$ ins. Total weight in service, 75.6 metric tons; adhesive weight, 64.3 tons. Total weight, engine and tender, 114.3 tons. The inside diameter of the boiler is $68\frac{7}{8}$ ins. There are 304 tubes, 2 ins. outside diameter. The fire box sheets are copper, $1\frac{1}{8}$ ins. thick, and the tube sheet is also copper, $1\frac{1}{8}$ ins. thick. The steam pressure, 205 lbs.

ERIK V. SNALL.

Sköfde, Sweden.

Position of Reverse Lever on Piston Valve Engines.

In my opinion to-day, the piston valve engine, as we find it, is not being handled

cylinders, and to meet the above requirements a relief valve or pop was inserted in both rear and forward ends of each cylinder; of course, with the inside admission piston valve, when the main piston is coming toward the completion of its stroke, the valve at this time is passing over the steam port to that end of the cylinder in order to open the port and admit steam to drive the piston back, just at this time all the danger is encountered, the receiving port being blanked by the passing of the valve, and if water is in the cylinder, water cannot be compressed; and if a pop or safety valve is not used in the head, it will undoubtedly break the head, or the cylinder packing, or if there is a weak place in the cylinder castings, or frame between them and the main crank pin, in all probability there will be a breakdown. It should be borne in mind by men handling the piston valve engine that water should not be allowed to get

into the cylinders when engine is being worked with an open throttle.

Now, my idea of handling the piston valve engine when drifting down a grade of several miles at a stretch, or when a passenger train is drifting into a station where a stop is contemplated, is to allow the lever to remain in the cut-off until the engine is about to stop, which time it should be dropped into the corner or as close to the corner as it may be deemed advisable to place it. This, then, will clean off the valve seat of any smoke or dust that may be drawn into the valve chamber by carrying the lever on the mid-travel, or center of the quadrant, the relief valve will be closed at this time, preventing cold air getting into the steam chests and cylinders, thereby keeping the walls and packing rings warm, and the lubricant can then perform its work to the best advantage. If a locomotive is allowed to drift down a grade of 17 or, perhaps, 20 miles, you can see that the metal in the walls of the steam chests and cylinders will become chilled to such a point that it will be impossible to get the oil to the packing or walls, and the inevitable result is that the packing becomes worn out in a short time and walls of cylinders scored badly. And the cool air that has been admitted into the chest and cylinders has a very detrimental effect on the saddle castings, etc. That is one reason why the reverse levers of piston valve engines should be carried on the center or approximately close to it, in the descent of all grades where steam is not used. When it is considered that the metal in a pair of cylinders has been heated up to the temperature of steam, and a 20-mile grade descended allowing the cool air to flow into the cylinders, particularly with the reverse lever in the full forward notch, it will readily be perceived that this sudden cooling of the metal one day with another and continued for several months or a year or two, the time will finally come when the saddles are found cracked, due, in all probability, to the continued contraction and expansion of the metal in the cylinders from alternate heating them by steam, and cooling them by the atmosphere.

Then, again, by carrying the reverse lever in mid gear, the valve travel is thereby shortened, and instead of the load being carried on the forward motion eccentric straps, it will be about evenly distributed over the four eccentric straps; this, then, lessens the work that must be performed by all the straps. Then, it will be noticed that the oil cups, and babbitt liners, set screws, eccentric rod bolts, will not become loosened and knocked off, this short travel of the valve will prevent lost motion wearing into the valve gear so rapidly. In fact, by this method, a great saving can be effected in the general wear and tear of the valve gear. Of course, among enginemen, we will be told

that by carrying the lever up as above indicated that the bushing will be worn and hollowed out and the seat worn uneven; to this it can be said that a bushing can be replaced more cheaply than can all the valve gear. Of two evils, the less should be chosen always.

We might as well add in passing that with a D-slide valve engine it is not altogether proper to carry the reverse lever in the full forward motion; it should not be let down any further on the quadrant than is in keeping with the rate of speed that engine is running. When the throttle is closed, the first impulse is to let the lever down, and in doing so it should only be let down gradually until a weight is found coming on the lever, then the latch should be dropped; it is unsafe to drop the lever any further. The seat will not be cut, as many engineers may assume under these circumstances, the reason being that the air being pushed out by the main piston will naturally raise the valve from its seat and escape into the exhaust; this air escaping will eventually carry the

Air and water are the great natural distributors of mechanical energy. The currents of rivers represent a portion of the mechanical equivalent of solar heat expended in raising the masses of water that flow through their channels to the clouds. The winds that propel our ships and wind motors are the product of solar energy also. The chief and most economical means by which the heat, generated in the combustion of fuel can be converted into mechanical energy for the propulsion of machinery is water, which the heat converts into steam.

We notice in an industrial paper of twenty-five years ago that one of the worst grievances complained of by workmen in Pennsylvania was the store order system. If that system has changed since that time it has been for the worse. It has also extended itself into many other States in the meantime. That store order system tends to keep workmen poverty stricken and under the thumb of petty bosses. It also tends to



BOILER OF ENGINE ON SWEDISH STATE RAILWAYS.

weight of the valve, preventing it cutting the seat, and so on. But, on the other hand, the piston valve cannot be raised from its seat as can the D-slide valve, and when it is allowed to travel at full stroke drifting down a long grade, it should be obvious what the consequences will be. An engineer that will give strict attention to the carrying of the reverse lever of his piston valve engine, one trip with another, it may be safe to assume that at the end of a year he will save to his company 50 per cent. of his salary. We have been preaching the above doctrine on three of the divisions of the road south of Bradford for the past 10 months, and the results thus far has been very gratifying; the engines are riding easier, not so much pound; in fact, no pound due to compression driving the rods and driving journals back against the boxes. And to my mind, about the only thing to do is to get rid of our prejudice against the piston valve engines and operate them in the right way.

JAS. SPELLEN,
Road Foreman of Engines, B., R. & P.
Bradford, Pa.

throw them into the arms of labor agitators, for it is a real grievance that can easily be made an explosive.

Robert Wilhelm Bunsen, the famous chemist and inventor, began the important work of his life with gas analysis from which came the invention of the now familiar Bunsen burner, and the charcoal pile. He discovered two of the rarer metals, viz.: Caesium and Rubidium. The spectroscope, perfected by Kirchoff, enabled these two friends and men of science to study the metals of the sun and the stars, and their investigations into the performance of light under various conditions, resulted in wonderful advances in science and in the arts. As a chemist Bunsen was one of the greatest that ever lived, yet he was always most modest. He had a kind and generous disposition. He died in 1899, being then 88 years old.

The Bullock Electric Manufacturing Company, Cincinnati, issue calendar cards, containing biographies of the great men of science.

Curious Express Locomotive.

The accompanying illustration, taken from *The Locomotive Magazine*, shows a design for an express locomotive and tender, suited for the British loading gauge, which is suggested as likely to meet the conditions of the present day. It may be said, says the magazine named, that the general arrangement is adapted from a Continental design which has been introduced on the Southern Italian Railway by Signor Planchar, director of locomotive power, with great success. The chief departure from ordinary locomotive practice consists in the reversal of the boiler upon the frames, the absence of a dome, and the carrying of the coal supply in side bunkers on the footplate. The primary advantage of this arrangement is the possibility of providing a fire box of considerable size without difficulty. There are many other subsidiary good features to be noted. In the large engines now running the employment of Belpaire fire

The coal bunkers are arranged on either side of a central passage by which communication is established between the driver's platform in front and the fireman's footplate. This construction obviates the unpleasant dust almost inseparable from a front bunker.

If the total extent of heating surface provided does not appear to give an amount in excess of the most recent modern practice, on the other hand it is claimed that advantage has been taken of the general dimensions to insure ample water spaces for both fire box and tubes, and as is well known the advantages arising from efficient circulation are of far more value than any mere aggregation of surface in which due provision is not made for the free passage of the heated water upwards. It cannot be said that 276 tubes of 2 in. diameter unduly crowd a boiler barrel which has a minimum diameter of 5 ft. 4 $\frac{7}{8}$ in. The fire box shell is square in plan, the width being equal

enough to please them either in this country or in Canada, so they went over to Scotland and Germany, with their portmanteau packed, so to speak, with their own blue prints and they said to the builders in Great Britain and in the Fatherland, "Build us engines according to these drawings and specifications, and don't deviate a hair's breadth," and the foreign builders obeyed instructions to the letter, and the result is that the engines can't be distinguished a quarter of a mile away from those built on this side of the water, and no "European" practice is being followed, and there is no "invasion."

The Master Car Builders' Association will hold their next annual convention at Saratoga Springs, N. Y., June 22 to 24, 1904, inclusive, headquarters at Grand Union Hotel. The American Railway Master Mechanics' Association will hold their next annual convention at Saratoga Springs, N. Y., June 27 to 29, 1904, inclu-

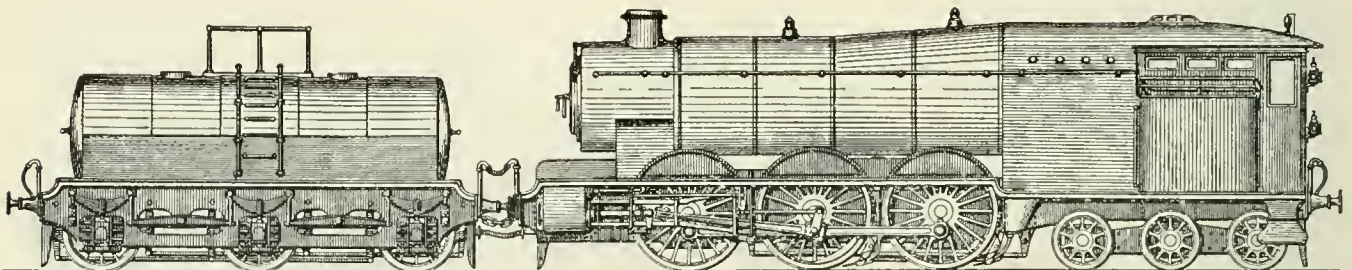

CURIOUS EXPRESS LOCOMOTIVE.

boxes, allied to large boiler barrels raised to the utmost limits permissible by the loading gauge, cause serious trouble to the engine staff in the way of obtaining a proper view of the road in front. After the cab has been raised and widened to the greatest extent possible, the space available for front windows is still inadequate under present conditions, and what defective view may thus be gained is further minimized by the downward swoop of steam and smoke from the chimney, or apology for a chimney, which these high-pitched boilers allow of. In the United States these difficulties were avoided to some extent by placing the driver in a separate cab on the boiler barrel, but this is now no longer possible, even with the larger limits of the United States loading gauge, and it had the drawback of isolating the two men in charge, and to that extent throwing additional responsibility on each in the performance of duties that are never of a light character. The arrangement supplied gives the driver an unobstructed view ahead, and yet leaves him in direct control of the working of the machine, besides giving him what assistance in his lookout may be spared by the fireman from his own proper duties.

to the length, 7 ft., and there is a grate area provided of 37.5 sq. ft. The heating surface is designed to give a total of 2,402 sq. ft., of which the fire box could provide 161 sq. ft. and the tubes 2,241 sq. ft. The roof of the internal fire box is shown to be inclined downward toward the fire door end at an angle sufficient to insure a water covering when the engine is on an ascending grade, which is an essential provision on such a machine. The boiler is constructed to carry a working pressure of at least 200 lbs. per sq. in. and is provided with two separate "pop" valves.

No Invasion.

A very absurd newspaper "story" has been going the rounds in the non-technical press to the effect that not long ago a number of German locomotives had been landed in Boston, and the general impression created by reading any of these paragraphs is that some of our big roads are going to test the latest type of "European" engines on a large scale, or that something has gone wrong with locomotive builders in this country and that Germany is "invading" the U. S.

As a matter of fact, the Canadian Pacific Railway could not get engines fast

sive, headquarters at Grand Union Hotel. Applications for hotel accommodations should be made to Woolley & Gerrans, care Hotel Marie Antoinette, 67th street and Broadway, New York City, up to May 1, 1904. After that date to Woolley & Gerrans, Grand Union Hotel, Saratoga Springs, N. Y. Applications for exhibition space should be addressed to Mr. J. Alexander Brown, Secretary, Room 17, No. 24 Park Place; New York City.

So many good instruction books for the use of enginemen have been written of late years, that those who benefit from this kind of literature ought to be interested in the pioneer who first published notes of his own experience for the benefit of the rising generation. This was Mr. S. A. Alexander, whose "Ready Reference for Locomotive Engineers and Firemen" was for years the only printed help these men received. He is now living in York, Pa., and looks as if he would enjoy many years of comfortable retirement.

There are certain polite forms and ceremonies which must be observed in civilized life, or mankind relapse into their original barbarism.—*Nicholas Nickleby*.

Passenger Power for the El Paso & Southwestern.

The El Paso & Southwestern have recently purchased four simple engines for passenger service from the Baldwin Locomotive Works, of Philadelphia. The engines, as will be seen from our illustration, belong to the 4-6-2, or Pacific type and have cylinders 22x26 ins. and driving wheels 63 ins. in diameter. The adhesive weight is 132,500 lbs. and with 200 lbs. boiler pressure, the calculated tractive effort of the engine is about 33,950 lbs. The valves are of the ordinary balanced D-slide type, and the motion is indirect. All the wheels on the engine are flanged, and they and the carrying wheels at the back are all equalized together.

The boiler is of the straight top type, with wide fire box and is designed to burn

Wheel base—Driving, 11 ft. 10 ins.; total engine, 30 ft. 9 ins.; total eng. and ten., 60 ft. 7½ ins.
 Weight—On driving wheels, 132,500 lbs.; on truck, front 36,800 lbs., back 40,200 lbs.; total engine, 209,500 lbs.; tot. eng. and ten.; about 340,000 lbs.
 Tender—Wheels, dia., 33 ins.; journals, 6 x 10 ins.

The "Rocket" and the "Sans Pareil," two of the three locomotives which in 1830 competed in the Rainhill tests in England, are both in the South Kensington Museum, but the whereabouts of the "Novelty" could not be traced until recently. It is believed to be still working as a stationary engine, the wheels having been removed. This interesting relic will, in all probability, be placed side by side with its contemporaries at South Kensington.

When Watt, the famous improver of the steam engine, wished to convert reciprocatory into rotary motion he in-

vented what he called sun and planet wheels, in which a gear wheel traveling in a circle gave rotary motion to a gear wheel secured to the driving shaft. Yet the crank was in general use and had been employed since the birth of civilization.

young ladies who sent in poetry, saying in honeyed language, that owing to the crowded state of his columns, etc., but he would endeavor to circulate their productions in manuscript. And then he tied the poems to the end of his kite for "bobs."

The gross earnings of the Chicago Great Western Railway (Maple Leaf Route) for the 1st week of November, 1903, shows an increase of \$26,523.54 over the corresponding week of last year. Total increase from the beginning of the fiscal year, \$353,959.22.

Sir Henry Bessemer, the great steel maker, carried on for years a business of making bronze powder by a secret process. When he began to amass a fortune by steel producing he made a present



4-6-2 BALDWIN FOR THE EL PASO & SOUTHWESTERN.

soft coal, with grate area of 52¼ sq. ft. The diameter of the boiler at the smoke box end is 74 ins. The total heating surface is 3,818.5 sq. ft., of which 3,624 is contributed by the tubes. These are 2¼ ins. in diameter and 19½ ft. long. There is a mud drum placed in the boiler barrel just back of the smoke box, and the injectors are placed one on each side.

The tender is carried on a channel iron frame. The tank with its water bottom will hold 7,000 U. S. gallons, and ordinary arch bar trucks are used. A few of the principal dimensions are as follows:

- Boiler—Thickness of sheets, ¾ in.; working pressure, 200 lbs.; staying, radial.
- Firebox—Material, steel; length 114 ins.; width, 66 ins.; depth, front, 75 ins.; back, 65¾ ins.; thickness of sheets, sides, ¾ in.; back, ¾ in.; crown, ½ in.; tube, ½ in.; water space, front, 4 ins.; sides, 3½ ins.; back, 3½ ins.
- Tubes—Material, iron; wire gauge, No. 10; number, 318; dia., 2¼ ins.; length, 19 ft. 6 in.
- Heating surface—Firebox, 184.5 sq. ft.; tubes, 3,624.0 sq. ft.; total, 3,818.5 sq. ft.; grate area, 52.25 sq. ft.
- Driving wheels—Dia., outside, 63 ins.; journals, main, 10 x 12 ins.; others, 9 x 12 ins.
- Engine truck wheels, front—Dia., 33 ins.; journals, 6½ x 2 ins.
- Carrying wheels, back—Dia., 40 ins.; jour., 8 x 12 ins.

Among the features of Louisiana's transportation exhibit at the coming exhibition in St. Louis, will be a miniature train of rice cars and cane cars, made of wood. There will be a real steam engine, though proportionately Lilliputian, to draw these infantile devices through miniature fields. The cars will be loaded with sections of real sugar cane and tiny sacks of rice.

The very foundation of science is the faculty of calling things by their right names, for by such a method only can one be perfectly understood and answered accordingly.

When Benjamin Franklin was an editor he was in the habit of writing to

of his bronze powder-making plant to two of his assistants.

Light nickel plating can be made by heating a bath of pure granulated tin, argol and water to boiling and adding a small quantity of red-hot nickel oxide. A brass or copper article immersed in this solution is instantly covered with pure nickel.

A curious thing that strikes a reader of the development of the steam engine is the persistence with which the parallel motion for guiding the movements of the piston rod was adhered to. At set of guides seems to have been an obvious invention, but somehow the pioneers preferred the difficult way, for fitting up a good parallel motion called for the skill of a first-class mechanic.

As good almost kill a man as kill a good book. Who kills a man kills a reasonable creature, God's image; but he who destroys a good book kills reason itself.—Milton.

Railway and Locomotive Engineering

A Practical Journal of Railway Motive Power and Rolling Stock.

Published Monthly by

ANGUS SINCLAIR CO.,

174 Broadway, New York.

Telephone, 984 Cortlandt.

Cable Address, "Loceng," N. Y.
Glasgow, "Locauto."

Business Department:

ANGUS SINCLAIR, President.
FRED M. NELLIS, Vice-President.
JAMES R. PATERSON, Sec'y and Treas.

Editorial Department:

ANGUS SINCLAIR, Editor.
F. M. NELLIS,
GEO. S. HODGINS, } Associate Editors.
JOS. A. BAKER,

Advertising Department:

Eastern Representative, S. I. CARPENTER, 170 Summer St., Boston, Mass.
Western Representative, C. J. LUCK, 1204 Monadnock Block, Chicago, Ill.

British Representative:

THE LOCOMOTIVE PUBLISHING CO., Ltd., Amen Corner, Paternoster Row, E. C., London.

Glasgow Representative:

A. F. SINCLAIR, 7 Walmer Terrace, Ibrox, Glasgow.

SUBSCRIPTION PRICE.

\$2.00 per year, \$1.00 for six months, postage paid to the United States, Canada and Mexico. For other parts of the world, \$2.50 or ten shillings. Single copies, 20 cents. Remit by Express Money Order, Draft, Post Office Order or Registered Letter.

Mailing address can be changed as often as necessary—always give old and new address, and if you subscribed in a club, state who got it up.

Please give prompt notice when your paper fails to reach you properly.

Entered at Post Office, New York, as Second-class mail matter.

Copyright by Angus Sinclair Co., 1903.

For Sale by Newsdealers Everywhere.

Compound Engines.

When thoughtful men studying the operation of the steam engine noted the high proportion of heat wasted by passing out of the cylinders in the form of exhaust steam, they naturally asked the question: Is it not possible to make use of the energy represented by this exhaust steam? The stationary steam engine had not been long in use when a practical attempt to utilize the exhaust steam was made in the invention of a compound engine. That was in 1781, and the inventor was Jonathan Hornblower, whose patent claim reads: "I employ the steam after it has acted in the first vessel (cylinder), to operate a second time in the other, by permitting it to expand itself which I do by connecting the vessels together and forming proper channels and apertures, whereby the steam shall occasionally go in and out of the said vessels."

As the boiler pressure in those days seldom exceeded 10 lbs. to the square inch, there was very little heat loss prevented by expanding the steam through two cylinders; in fact the cylinder condensation resulting from the increase of cylinder area operated through wasted steam, and so the first compound engines were failures, although the principle

which the inventor tried to work out was based on sound engineering.

Although Hornblower's attempt to improve the steam engine was not a success, he had pointed in the direction of advancement and his discernment of possibilities led his successors to work in the same line. During the first half of last century many compound engines were built and they became noted for their durability, which was due to the strains of action being more evenly distributed than they are in simple engines; but there was no decided economy in the use of steam in the compounds built in Europe during the first half of last century which was due to the low boiler pressure in vogue. American engine builders used considerably higher boiler pressure than what prevailed in Europe, and they had it in their power to make compound engines that would effect saving of steam. As early as 1825, James P. Allaire, of New York, built compound engines for marine service that gave a horse power on less steam than any engines that ever had been worked up to that time; but American marine engineers were prejudiced in favor of the light, high-pressure, high-speed engines that had become the national type, and Allaire's ingenuity, skill and enterprise did nothing to convince the engineering world that the compound had the inherent right to become the steam engine of the future.

In 1854 the forerunner of the successful compound engine was built under the direction of John Elder, a member of a well-known ship building firm in Glasgow. Elder was a leading spirit among a group of Scots mechanical engineers, who were laboring to lead their profession away from beaten paths into new fields of enterprise. He was an accomplished engineer and an industrious investigator into the peculiarities of heat phenomena which guided him on the safe way to work out improvements on the marine engine then doing its work on a coal consumption of about 6 lbs. of coal per horse power per hour. Elder perceived that the compound engine had proved itself more efficient than the single cylinder engine only when the pressure of steam carried and the extent of expansion exceeded the practice customary at that time. Following the obvious teaching of this fact, he applied high steam pressure and a high ratio of expansion to well designed compound engines, and reduced the coal consumption from about 6 to 3¼ lbs. per horse power per hour. As boiler pressures were still further increased and various improvements effected on the mechanism, the coal consumption has been steadily reduced till now, with quadruple expansion engines, very little more than one pound of coal produces a horse power.

The change introduced by Elder was the greatest improvement effected on the steam engine since the separate con-

denser was applied, and made possible the high speed now common with steamboats.

When the compounding of marine engines was demonstrated to be a fuel reducing operation, the principle was gradually extended to stationary engines; but the improvement was effected very slowly. The introduction of the compound engine excited surprising opposition. The opponents of the change acted more like politicians eager to defend the spoils of office than like business men considering the merits of an engineering problem. The cost of power is, however, such an expensive element in manufacturing, that an engine capable of cutting the coal accounts in two was bound to make its way and so the compound itself conquered all opposition.

The owners of locomotives and the men having charge of railway motive power, were by no means precipitate in trying to secure the benefits that others had derived from the use of compound engines. There were good and sufficient reasons for this. The simplest form of a compound locomotive added some parts to the simple engine and moved by the lessons that come from long experience railway motive power men have been a unit against complexity in locomotives. They understood that a compound locomotive that failed to take out and in trains as regularly as simple engines, would be unsatisfactory, no matter what saving of fuel they might effect.

Attempts were made by various inventors to produce a compound locomotive even before the compound marine engine was made a decided success; but they were all commercial failures until Anatole Mallet, a French engineer, devoted himself to working on the problem. In 1876 the Bayonne & Biarritz Railway Company, of France, had two locomotives built according to Mr. Mallet's designs. They were small experimental engines, but they were the seed that produced the abundant crop of compound locomotives found all over the world to-day.

The first railway official to follow Mr. Mallet's lead was Mr. Von Borries, mechanical superintendent of the Hanover Railway, who built a number of compound locomotives modified in various details to meet his own views. This was followed by Mr. T. W. Worsdell, locomotive superintendent of the Great Eastern Railway of England, who designed and applied an intercepting valve that became a pattern for other designers of two-cylinder compound locomotives. The leading features of the Worsdell compound locomotive were a single high-pressure and a single low-pressure cylinder connected to cranks set at right angles with a cylinder ratio of about 1 to 2. Slide valves were used to cut off steam at the points considered most desirable for economical working. A receiver inter-

vented of about the capacity of the high-pressure cylinder and it was located in the smoke box with the view of having the steam heated by the smoke-box gases. This type of compound has come to be called cross compounds in the United States.

Two years after the Mallet compounds were put into service, Mr. F. W. Webb, locomotive superintendent of the London and North-Western Railway, built a two-cylinder compound following Mallet's lead, and it was found to work satisfactorily. Mr. Webb is a man of such strong personality that he could not be satisfied to imitate any design of a railway appliance, so he brought out a three-cylinder compound with one inside cylinder acting as low-pressure cylinder for two outside high-pressure cylinders. The influence of the inventor was sufficient to put a great number of these engines into service, and in 1889 the Pennsylvania Railroad Company imported one of these engines to find out how well it was adapted to the hauling of trains in the United States. The engine was by no means a success, but it seemed to introduce among us a prejudice in favor of compound locomotives, which created a demand that was readily supplied. It is not necessary at this time to enter into details of the history of compound locomotives in the United States. We will only comment on the reasons why a compound locomotive should do a certain amount of work with less fuel than a simple engine.

The fundamental purpose of all improvers of the steam engine has been to convert an increased proportion of the heat energy of the steam that passes from the boiler into the mechanical energy available for performing useful work. An axiomatic principle recognized by all engineers conversant with thermo-dynamics is "The higher the temperature of the steam when it enters the cylinder and the lower that which it reaches before the exhaust occurs, the greater will be the efficiency of the engine, if the reduction of temperature has been caused by the conversion of heat into useful work." The engine that will best perform this function transforming the energy of heat into useful work will in the end prove most efficient.

Locomotive improvers have adhered very closely to a certain sound principle in steam engineering and generation after generation have moved in cycles, working on the problem of admitting the steam quickly into the cylinders at near boiler pressure, cutting it off at the shortest point consistent with the work to be done, and expanding it as low as practicable before opening the exhaust. That is, they do their best to provide for the maximum expansion of steam in the ordinary cylinders. Mr. D. Kinnear Clark, the eminent engineer, who wrestled long with in-

vestigations into the most economical methods of operating locomotives, came to the conclusion more than half a century ago that "expansive working was expensive working"; yet his discoveries did not deter others from laboring to perfect means for admitting and cutting off steam quickly, with a view of obtaining a high ratio of expansion in locomotive cylinders; but the labors in this direction have uniformly resulted in disappointment. Clark, who first demonstrated that a high ratio of expansion in locomotive cylinders was not conducive to economy, discovered and explained the cause and at the same time furnished a rational solution of the difficult question, why a compound engine providing for a higher ratio of expansion than a simple engine might yet be more economical.

This discovery was to the effect that the cylinder of a steam engine acted alternately as a condenser and as a boiler, condensing a portion of the steam during admission and re-vaporizing the resulting water of condensation during the period of expansion and exhaust. This is due to the interaction of the metal of which the cylinders are made and is inevitable with material that forms a good conductor of heat. When the steam becomes water in the cylinder it loses its power to do mechanical work; therefore, the percentage of steam that condenses, through the interaction of the cylinder metal represents so much loss of power. A portion of the steam condensed becomes spray and helps to dampen the steam entering the cylinders, vitiating its capacity for doing work.

This may appear to be a fine-spun theory to those who have not studied steam matters closely; but it is a theory founded upon the discoveries of highly practical men. The serious heat losses that occur in the steam engine through cylinder condensation and re-evaporation are well known and acknowledged by the best authorities. They have been as clearly proved as anything belonging to steam engineering; yet few railroad men act as if they realized the importance of the matter. There are probably few locomotives that lose less than 25 per cent. through condensation of the steam used. Locomotive cylinders are more exposed to refrigerating influences than the cylinders of any other form of engine, yet very little attention is given to keeping them protected.

An impression prevails that steam is saved in a compound engine because it is used in more than one cylinder, thereby utilizing as much as possible of its expansive properties. That increase of expansion would probably cause actual loss through excessive cylinder condensation were it not that extremes of temperature are prevented by using two or more cylinders, giving a low average pressure in each. Take, for instance, the cylinder of

a simple engine using steam at 200 lbs. gauge pressure. That steam has a temperature of 381.6 degrees Fahr. on entering the cylinder and it would drop to about 25 lbs. gauge pressure when the exhaust was open. The temperature of the latter pressure would be about 240 Fahr., a difference of 141.6 degrees. The cylinder metal would naturally drop toward the temperature of the exhaust steam, making it ready to condense the incoming steam at the return stroke. That same steam used in a compound cylinder would, in ordinary working, be exhausted into the receiver or into the low pressure cylinder at a pressure of about 70 lbs. pressure, making the extremes of temperature from 381.6 to 303, a difference of only 78.6 degrees, as compared with 141.6 degrees. The changes of temperature in the low-pressure cylinder are comparatively small for the steam will pass in at about 300 degrees Fahr. and be exhausted at about 240 degrees, a drop of about 60 degrees, which is comparatively small.

Another advantage gained by the compound in the use of steam is that part of the condensed vapor passing out with the exhaust steam is re-evaporated by drawing heat from the cylinder walls or by what is called the interaction of the cylinder metal. In a simple engine that re-generated steam passes out with the exhaust or helps to increase the back pressure; in a compound it passes into the low-pressure cylinder and does useful work.

Value of Knowing Common Things.

Many people nowadays turn up their noses on hearing the homely saying, "Where there's a will there's a way," because so many of them are waiting to be coddled into the way, without displaying the least trace of a will for well doing, or for self help.

So much has been preached of what a college education will do for people, that crowds of youths drag through a college course and then expect that their fortune is made; whereas they are at the real commencement, as the graduating proceedings are rightly called. The man or woman who has the energy to make a way will always leave behind all others devoid of active ambition, no matter how well favored their start has been by circumstances.

The ordinary graduate depends too much upon the knowledge acquired in a college course, whose real value is in training the mind how to acquire and digest useful knowledge. There is too much generalizing and too little digesting of details. It is not easy descending from the genteel speculative to the prosaic working out of details. Observation of common things is good training to help in collecting professional knowledge. City life and training have a tendency to develop a certain species of

sharpness, but for most people it blunts the observing faculties.

The writer was riding through the parks of a great city with a town-bred lawyer, who acknowledged that he did not know one tree from another. That man knows something of books, horses and law, but he is an ignorant creature, nevertheless. But his ignorance is only equal to that of many others whose daily labors are made less profitable for want of knowledge of common things. How many of our engineering graduates know how a steel tire is made and how it is held on a wheel center? How many of them can tell the proper cutting speed of machine tools for various metals? How many of them can tell when a machinist at the vise is doing a fair day's work? Very few, which is a weakness begotten of beginning business at the wrong end.

Civil engineers succeed in life by utilizing and controlling natural forces, and by making the best possible use of material that can be obtained convenient to their operations; yet many men who try the business are constantly handicapped through ignorance of common things. How many of them know what procurable timber will stand the heaviest strains or why white oak is proper for one purpose and not for another, and what timber will last best under water and what out of the water? How many know sandstone from limestone, or trap from granite?

How many know that a horse gets up before and a cow gets up behind and the cow eats grass from her and the horse eats to him? How many know that a surveyor's mark upon a tree never gets any higher from the ground, or what tree bears fruit without bloom? There is power of comfort in knowledge, but a boy is not going to get it unless he wants it and wants it bad, and that is the trouble with most college boys, they don't want it. They are too busy enjoying themselves and haven't got time. There is more hope of a dull boy who wants knowledge, than of a genius, for a genius generally knows it all without study. The close observers are the world's benefactors.

Untidiness and Waste.

Whether it is that untidiness leads to ruin, or that a manufacturer who is losing money has not the moral stamina to keep things in trim, thrifty shape, is a hard matter to determine, but true it is that untidiness in the shop and office and ruin are such close friends that they are ordinarily seen together, and the sight of one suggests the other.

We have often seen men of rare industry, judged by their bustling manner, who would spend much time each day looking for tools which they had forgotten where they left; stumbling over piles of stray castings under the lathe or piled under the bench, or pawing those castings over for a piece somewhere in this pile

or that, when it ought to be in a place by itself; going from tool to tool, bench to bench, to find or borrow a drill, or wrench, or hammer, or block, when there should be just one place to find the desired article. And when the articles are found he never thinks of returning them to their proper place. In fact, there will be no "proper place" for tools in such a shop, and the next man that wants them will go on the same hunting expedition about the shop.

Such a shop will always have black and dirty walls and ceiling, with windows spattered with dirt and decorated with cobwebs, notwithstanding that the light is so bad that careful work is rendered impossible or tedious of accomplishment, when a few cents' worth of lime and a brush would whiten the walls and the ceiling and greatly improve the light and so expedite and improve the work. Money and time are lost and ruin invited by a neglect of these things. We have all found railroad shops that this description applies to.

But the greatest loss experienced by this deplorable and needless state of things is in the morals of the shop. Workmen compelled to work in a dingy, ill-kept and ill-lighted shop will suffer loss of self-respect and respect of their employer and his interests. If they are forced to work at disadvantage, the stimulus to activity and ingenuity suffers a gradual decay and no one will pretend to deny that this decadence on the part of the workmen is a direct money loss to the proprietor. Tidy workshops stimulate manliness and ingenuity on the part of workmen, and right there may be found the profit on the year's business, or, if neglected, on the year's losses. There are plenty of establishments in which by a careful attention to these matters—too often regarded as non-essential—the efficiency of their workmen could easily be increased 10 per cent., and that per cent. would determine the difference between a profit and a loss.

Book Reviews.

Pocket Book on Boiler-Making, Ship-Building and the Steel and Iron Trades in General. By Maurice John Sexton. Publishers, Spon & Chamberlain. New York: 1903. Price, \$2.00.

This work, which is named on the outside cover, "Sexton's Boiler-Makers' Pocket Book," is of the ordinary size, 4½x3 ins. It is attractively bound in bright red Morocco, with black elastic strap and gilt edges. It is well illustrated throughout and contains 319 pages, with blank pages for memorandums in front and back, and has an alphabetical index.

The pocket book comprises a variety of useful information for employees and workmen, inspectors, engineers in charge of works and ships, foremen of

manufactories and steam users generally. The present issue is the sixth edition revised and enlarged. It contains numerous tables, calculations, data and instructions such as practical men require, and all are compressed into the very compact form necessary for a pocket book.

A very useful appendix to the section on boilers is to be found on page 237. In it are given the cost of making and contract, or selling price of things that have been made, such boilers, ships' masts, railway bridge girders, and other articles which have been made by boiler makers. This appendix is invaluable as a basis of comparison for those doing contract work.

Locomotive Slide Valve Setting. By C. E. Tully. Publishers, Spon & Chamberlain. New York, 1903. Price, 50 cents.

This is a pamphlet of 31 pages with illustrations on nearly every page. It is written from knowledge gained by practical experience and is intended for apprentices and others. Marine work is also treated.

Helping to Make Hard Times.

Railroads quite generally have stopped ordering new cars. They look for a falling off in traffic next year, and they think their present equipment will be sufficient to take care of all the traffic they may have to handle. On this account car manufacturing companies are beginning to reduce their forces.

This is how panics and depressions of business are cultivated. It is merely history repeating itself for railroad companies to begin prostrating business by stopping work and cutting down every department where retrenchment is possible immediately on any small cloud of business depression appearing on the horizon. Unfortunately, Wall Street influences act like a wet blanket on the whole trade of the country, for their fiat stops the wheels of industry that unearned dividends may be used to float stocks above their real value. We have heard a great deal said during the last three years about the desirability of railroad companies establishing manufacturing plants for rolling stock. Happily, the talk never took a tangible form and there are no great railroad plants to be closed and thereby add to the momentum toward hard times.

Properties of Materials.

In studying the different properties of materials there are great differences of characteristics so far as strength alone is concerned. There is, for instance, tenacity which enables a wire to exert a strong pull without breaking. Steel wire, such as is used for the piano, is in this sense the strongest

substance known. Wrought iron is much more tenacious than cast iron.

Strength to resist crushing is of a different quality, and is possessed by cast iron to a higher degree than by wrought iron.

Hardness is that particular kind of strength which gives the power to scratch or cut or to resist being scratched or cut. Glass will scratch iron, but pure iron will not scratch glass. Glass is, therefore, said to be harder than iron. The hardest substance known is diamond, which is crystallized carbon. It easily makes scratches and even cuts glass and will do this every day for years without losing its edge. Next to it comes corundum, or crystallized alumina, of which the ruby is one form. Some other precious stones, such as the sapphire, topaz and emerald are largely composed of alumina, as is also emery, so well known for its abrading powers, which causes it to be used so largely for grinding purposes.

Another very hard substance is silica, which, when crystallized and clear, is called rock-crystal. Agate, jasper, flint and quartz are other specimens of it. It is much harder than glass.

The hardness of steel depends very much on whether it is cooled gradually or suddenly from red heat. The more sudden the cooling, the harder it becomes, and the operation of hardening steel by dipping it when hot into a cold liquid is called tempering. The opposite process of softening by gradual cooling is called annealing. In steel rolling mills there are cavities where hot steel castings are left to cool gradually to make the mass of uniform hardness. The process gone through having been that of annealing. Connected with nearly all machine shops there are furnaces where articles can be annealed after being manufactured. Connected with all glass-making establishments there are annealing ovens in which the newly-made glass vessels are left to cool down gradually from red heat. This process of annealing relieves an article from the local strains that would be set up through the contraction of uneven cooling.

The student of engineering when told that the work required to lift a weight is identical whether done in a second or an hour accepts the truth with a lingering feeling of a difference existing somewhere, until he learns that the difference is one of power or the rate of doing work. The power required to do a certain measure of work in one minute is much greater than that required to do it in one hour. Hence, the necessity for distinguishing time as an element in the performance of work.

QUESTIONS ANSWERED.

(1) P. S., Buffalo, N. Y., asks:

If I break the intermediate eccentric rod between link and valve stem, what parts must I disconnect? A.—Take down the broken parts only, then secure valve stem after covering steam ports, block cylinder cocks on disabled side open and leave main rod up. See article on main rod in breakdowns, November issue; page 505.

(2) B. E. S., Brooklyn, N. Y., asks:

Can a Schenectady compound handle her train and what must be done, if the main rod on the high pressure or low pressure breaks? A.—Yes; she can handle part of a train. With the rod on the high pressure side broken, push the valve ahead to clear the exhaust port and block piston ahead. The low pressure then gets steam direct. If the rod on low pressure side breaks, push the low pressure valve back to clear exhaust port and block piston back. This gives a direct outlet for the live steam through exhaust port of low pressure cylinder.

(3) A. R., Pittsburgh, Pa., says:

A and B have a dispute over throttling an injector. A says an engine will steam better to throttle the steam at the fountain, while B says it makes no difference in her steaming. Who is right? A.—A, of course, is right. If the valve is throttled too much, the steam will not condense, and if the overflow is too small to allow it to discharge freely the injector will break. If the steam nozzle is too large, throttling is the only remedy, as it reduces the amount to be condensed, strengthens the vacuum in the combining tube and increases the capacity, resulting in a better steaming engine.

(4) W. R. M., Cleveland.—1. Has ever any tests been made to find out the proportion of coal that is wasted by passing through the flues of an engine as sparks? If so, what was the proportion found? A.—From 10 to 25 per cent.

2. Would an invention designed to keep all the coal in the fire box have any value? A.—It would have value if it was practicable.

(5) A. S. B., Scranton, Pa.—What is the meaning of the expression "a know-nothing stop?" A.—When trains are required to stop at railroad crossings and drawbridges they are popularly called know-nothing stops. The current belief that the expression is used because the stop might be avoided by the use of automatic interlocking signals is not correct. The first law requiring such stops to be made was passed by what was called the "know nothing" Legislature of Massachusetts in 1855. The contemptuous appellation of the Legislature has adhered to that species of stop.

(6) A. J. S., Macomb, Ill., writes:

1. We have a Forney type engine, bought from the South Side Elevated in Chicago. She is a Vauclain four-cylinder compound, and the man who set her up according to the marks left her so that she would not run. A machinist from another point on the line went over the valve motion and pronounced her O. K., but she has only three exhausts and hardly moves with a full throttle. A.—You, no doubt, have a worn-out engine that needs the back shop's attention. When those engines were built for the Chicago Elevated the valve stem extended part way through the valve. Experience proved the weak points in the valve and in the later ones the rod extends through the entire length. The old-style valves have been known to break at the end of the rod and close up the steam port at that end effectively so that there would be only three exhausts. Probably that is the trouble here if the valve motion has been properly set by the travel marks.

2. What is the plug between the valve and high pressure in the outside casting for? A.—The plug you refer to took the place of the old by-pass valve that was discarded.

3. Is it true that the small lever on foot board controls the simple and compound feature? A.—The lever you mention controls three positions, cuts off steam, opens the cylinder cocks in one position. In the second position it admits live steam to the low-pressure cylinders and in the third position it blanks the two former as a cut-out cock.

4. What prevents a Nathan lifting injector from priming? A.—A leaky joint in the supply pipe at or near the injector, so that the primer cannot produce a vacuum, a choked strainer in the hose connection, or one with insufficient openings to prevent the free flow of water, or a closed tank valve.

(7) G. S. E., Kingston, N. Y., asks:

What is the object of the holes in the combining tube of the Monitor injector, especially the one which is about half way along the tube on the under side? A.—These holes are called auxiliary relief holes, they enable the water and steam to combine with less concussion. They allow the feed water to be used at a slightly higher temperature than it otherwise could be. They permit of better comingling of steam and water, as through them the water overflows easily until the pressure of the steam and the supply of water are properly proportioned. It is not absolutely necessary to have the hole half way along the tube always turned down.

(8) M. A. H., Stratford, Ont., writes:

(1) Take an engine with crank pin on forward center, the movement of the

lever from one corner to the other causes the valve to move backward and then forward, and when on the back center the same movement of the lever causes the valve to move forward and then backward. What is it that brings about this change? How is it done? A.—The center of the radius which determines the curvature of the link is generally at or near the center of the main axle, and if the eccentric rods actually terminated at that center the link could be moved up and down without causing any motion of the link block. The eccentric rods, however, revolve about the center of the eccentrics, and these centers are above and below the horizontal center line of the engine when standing, as you specify. Therefore, when the link is lifted the eccentric rods' ends move through small arcs of circles, each rod having a different center, and each describing a

was in with full forward gear. To start an engine either forward or backward the valve must be in the same position for both directions. When you put the engine on the back center and move the lever from full back gear to center the valve moves back to midgear lead position, and as you put the lever over into the full forward notch, the valve goes back to the lead position at beginning of stroke. (2) Which way do the drivers of a locomotive slip more, in going backward or forward, and if either, why so? A.—This matter was very fully explained in a contributed article which appeared on page 181 in our April, 1903, issue, which see. When moving forward the pull and push of the connecting rod on the crank pin has a tendency to hold the driving wheel down to the rail. It takes weight off the engine truck and transfers it to the drivers. The proof of this is found in

are 63 ins. in diameter. Our illustration shows clearly the direct motion feature of the valve gear. The center wheels are the main drivers and the eccentrics are placed upon the main axle, a cast-steel transmission bar passes over the forward driving axle and is attached to the lower end of a rocker of the same length as the one which moves the valve rod. The valves are of the piston type. The running board is extended the full length of the engine from cab to smoke-box front.

The boiler is a wide fire box, wagon-top one and measures 66½ ins. in the first course. The heating surface is 2,959.19 sq. ft., made up as follows: Tubes, 2,808.4; fire box, 150.79. The grate area is 46.27 sq. ft. The tubes are 337 in number and are 16 ft. long. The pressure carried is 200 lbs.

The tender has 10-in. steel channels and the trucks are 4-wheel Player cast-steel arch bars, truck with coil springs.

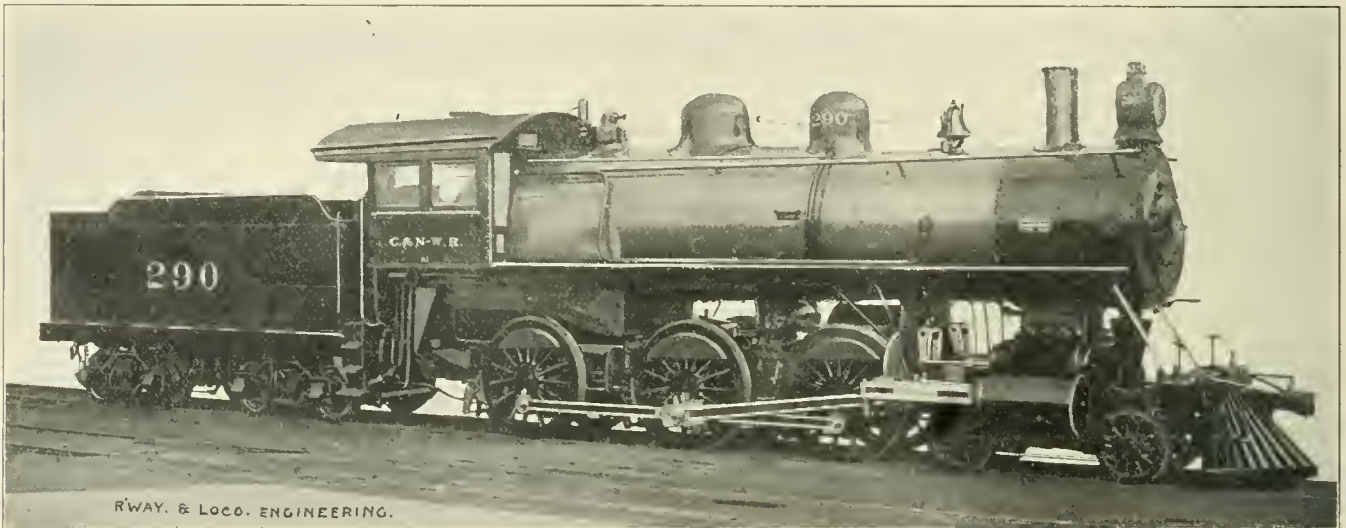

4-6-0 TYPE ENGINE FOR THE CHICAGO & NORTHWESTERN.

separate arc. The arcs are similar, but they are one above the other, and they cause the link to move parallel to itself. It is as if you took the similarly curved eyebrows painted on the face of a mask and joined them with a lead pencil, the blunt end of the pencil lying over the outer end of the left brow, and the sharp point resting on the end of the right brow close to the nose. Move the pencil, keeping its ends on the curved line of the eyebrows. The pencil would rise, and fall to the same level at the end of the operation as it was at the beginning. In like manner the link moves backward and forward. At the beginning of the stroke, the valve stands with lead opening for full forward gear with reverse lever in the corner ahead. Bringing the reverse lever to the center causes the valve to come to the midgear lead position, which is the greatest amount of lead it can have. Putting the lever in full back gear brings the valve back to the same position it

the wear of the top guide bar for habitually forward running engines. Backward movement wears the bottom guide and also takes weight off the drivers and puts it on the truck, and under the circumstances the tendency to slip is increased. A train, especially a freight train, is harder to push than to pull, for reasons set forth on page 204 in the May, 1903, issue of RAILWAY AND LOCOMOTIVE ENGINEERING. If the backing engine is also pushing a freight train, its tendency to slip will be greatly increased.

Simple 4-6-0 for the Chicago & Northwestern Railway.

The Schenectady shops of the American Locomotive Company have recently been supplying the Chicago & Northwestern with some fast freight engines of the ten-wheel type. Mr. Robert Quayle is superintendent of motive power and machinery of the Northwestern.

The cylinders are 21x26 and the drivers

The tank has a water bottom and holds 5,400 U. S. gallons. The coal capacity is 10 tons. The wheel base of the tender is 16 ft. 10 ins. A few of the leading dimensions are as follows:

GENERAL DIMENSIONS.

Weight in working order, 164,000 lbs.; weight on drivers, 129,000 lbs.; weight engine and tender in working order, 274,000 lbs.; wheel base, driving, 14 ft. 10 ins.; wheel base, total, 25 ft. 10 ins.; wheel base, tot., eng. and ten., 54 ft. 2½ ins. Valves—Piston type; greatest travel, 5¼ ins.; outside lap, 1 in.; inside, clear, ½ in.; lead in full gear, line and line full gear, F. and B. Wheels, etc.—Dia. of driving wheels outside of tire, 63 ins.; driving box material, main, cast steel, others, steeled cast iron; dia. and length of driving journals, 8¼ and 9 ins. dia. x 11¼ ins.; dia. and length of main crank pin journals, main side, 7 x 4¼ ins., 6¼ ins. dia. x 6 ins.; dia. and length of side rod crank pin journals, F. and B. 5 ins. dia. x 4 ins. Boiler—Thickness of plates in barrel and outside of fire box, ¾, ¾, ¾, ½, 1, ¾ and ½ in.; fire box, length, 102 ins.; width, 65¼ ins.; depth, front, 7½ ins.; back, 56½ ins.; material, carbon; plates, thickness, sides, ¾ in.; back, ¾ in.; crown, ¾ in.; tube sheet, ¼ in.; water space, 4 in. front; 4 in. sides; 4 and 5 in. back; smoke stack, top above rail, 14 ft. 11¼ ins.

C., B. & Q. Prairie Engine.

The photograph from which the engraving of the annexed prairie type locomotive belonging to the Chicago, Burlington & Quincy Railroad was made, was sent in by an admirer of the engine who was ambitious to see it adorning the pages of RAILWAY AND LOCOMOTIVE ENGINEERING.

Mr. F. H. Clark, superintendent of motive power of the Chicago, Burlington & Quincy, writing of this engine, says:

This engine is one of the first lot of Prairie type engines built by this company. We have only used these engines in freight service and find them very satisfactory, indeed. We subsequently built about 60 engines of the same type, but somewhat heavier, and last year 50 additional engines of the design. The

ed the Union Works on Foundry street, South Boston. His first venture was for the then Boston & Worcester Railroad, for which he built three passenger engines, the Falcon, the Fury and Bee, and three freighters, the Etna, Niagara and Bison, all patterned after the Hinkley engine of those days, with extremely short boilers to accommodate the engines for the short turntable for which the directors of the road spoiled all their engines.

His next attempt was a couple of passenger engines for the same road, the Hale and Henshaw, which were large engines for those days, having cylinders 15x22, 66-in. drivers, and a 46-in. shell, with long tubes.

These engines proved quite successful, when running, as they passed a good deal of their early life in the re-

for the Erie, sufficiently large for the gauge of that day, and then, I think, by some twenty of the "Tea Kettles" illustrated in your October number.

It is my remembrance that these were the last built at his works, which, on the whole, were not successful, from a financial point of view, and Mr. Wilmarth retired from further active business.

He became afterward master mechanic of the Boston Navy Yard, in which office he continued for a number of years, down to the time of his decease, I believe.

As a mechanic, Mr. Wilmarth had many excellences for his day and generation, and was a fruitful inventive power, as he turned out from his shop during its brief existence more types and different patterns of engines than



C., B. & Q. PRAIRIE ENGINE.

line engravings on next page give full particulars about the engines. The principal dimensions are:

Boiler crown stay—Fire box, 7 ft. long, 6 ft. wide x 62½ and 56 ft.; tubes, 191, 2½ outside dia., 16 ft. 1 in. long; heating surface, fire box, 130.6 sq. ft.; tubes, 1,826.7 sq. ft., total, 1,957.3 sq. ft.; grate area, 42 sq. ft.; steam ports, 23½ x 1½ ins.; exhaust ports, 23½ x 3 ins.; piston valves, max travel, 6 ins.; lead, full gear; inside clearance, ½ in.; lap, 1; weight on front drivers, 29,150 lbs; on main drivers, 43,260 lbs.; on rear drivers, 37,860 lbs.; total weight on drivers, 110,270 lbs.; weight on front truck, 14,100 lbs.; on trailing truck, 26,850 lbs.; total weight of engine, 151,220 lbs.; weight of tender empty, 35,000 lbs.; weight of water, 5,000 gals., 41,700 lbs.; weight of coal, 17,500 lbs.; total weight of tender, 94,200 lbs.; of engine, 151,220 lbs.; in working order, 245,000 lbs.

The Wilmarth Engines.

If further details with regard to the Wilmarth engines be worth publishing, you may find some herewith.

He graduated from the old Hinkley shop, somewhere about 1848, and erect-

pair shop, one of them, the "Hale," winning the second prize at the celebrated trial at Wilmington, Mass. The first prize being borne off by Wilson Eddy's 84-in. single driver, the "Addison Gilmore."

Shortly afterward Mr. Wilmarth built a number of engines for the Hudson River Railroad, with 78-in. drivers and outside cylinders, named after the various counties through which the road passed, the letters being placed on the side sheets of the tender and being about three feet high.

He built also a type which, since then, has become somewhat modernized, the Agawam for the Eastern road and the Plymouth for the Old Colony road, the drivers, four in number, and 54-in. diameter, being placed in the middle, and in front of the fire box, with a four-wheel truck in front, and a four-wheel trailer behind.

These were succeeded by a number

did the Hinkley Works, in the long and successful course of their primal organization.

But much of the mechanical work was poorly done, and few of his engines lasted long enough to be known for a decade.

And when one thinks of these ancient pioneers of motive power construction, he is reminded of Coleridge's lines:

"The knights are dust
And their good swords rust;
Their souls are with the saints, we
trust." GEORGE H. LLOYD.

It has been noticed that copper when melted with salt and subsequently cooled is much tougher than ordinary copper, this being due in all probability to the removal of cupreous oxide, which is present in greater or less quantities and has a breaking effect.

Harter's Patent Ball Joint.

We illustrate in the accompanying drawings a new type of ball joint, invented and patented by Mr. Godfrey Harter, of No. 1025 Walnut St., Philadelphia, Pa. This joint has been especially designed to give perfect flexibility while carrying the very highest steam pressures.

It will be seen that the ball piece A is held in place in the socket piece B by means of external stays, which are pivoted at CC on a steel ring, which itself is pivoted on to the socket piece B at D.

The pivots DD give the ring, stays and ball piece freedom to move in a plain parallel to the paper in Fig. 2, while the pivots CC give the stays and ball piece freedom to swing in a plane at right angles to this. The axes of the pivots, of course, intersect at the

center of the ball; hence the ball piece is free to swing in any direction and with a minimum of friction, however high the steam pressure.

Steam tightness is secured by an ordinary stuffing box and gland, as shown, assisted by water grooves cut in a bushing, E; or, if preferred, cut in the socket piece itself. It has been found an easy matter to keep this gland tight with soft packing, as there is always perfect alignment, due to the fact of the working surface being part of a true sphere.

A modification of the above type is shown in Figs. 3 and 4. This is designed to supersede the ordinary telescopic extension joint, and has been used in the British Navy for this purpose on the destroyers Greyhound, Racehorse and Roebuck, and the first-class cruiser, Antrim, recently launch-

ed. Fig. 4 explains the method of application on board ship. As the pipe expands the end moves in the direction of the arrow, Fig. 4. It will be seen that in this type the steel ring is dispensed with, the stays, which, for convenience, are made double, are connected direct to lugs on the ball pieces. By making these lugs spherical, slight play is allowed for, as in Fig. 3.

The great advantage of this arrangement as compared with the common telescopic expansion joint, is that it does away with the enormous unbalanced thrust exerted by the sliding joint.

Often the principal strains on piping and its joints are due to a bending action on the pipes, caused by expansion of the pipes themselves, or to separate movement of the parts connected by the pipe. By employing flexible con-

How Passengers' Trunks Came by Their Name.

Have you ever wondered why a box in which you pack your clothes is called a trunk? If you go to the old church of Minster, in Kent, England, you will there be shown an old wooden box, of which the rounded lid is made of a portion of a trunk of a tree hollowed out. This old box is supposed to be the actual box brought to England by William the Conqueror, who kept in it the money wherewith he paid his troops. So, from Normandy came the idea, which British ingenuity has improved upon, until the result is the traveling trunks with which we are accompanied in these days when we undertake an extended visit or a sight-seeing tour of the world, and by which we are enabled to dress as becomingly and comfortably, no matter what extremes of climate we may encounter, as though we were at home with wardrobes full of clothing at hand.—*Toronto News*.

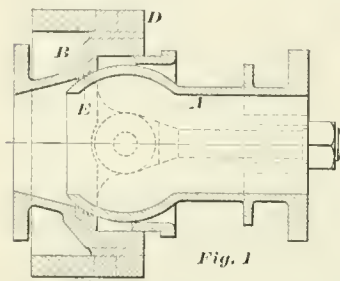

Fig. 1

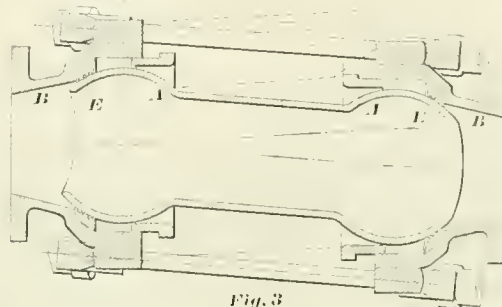

Fig. 3

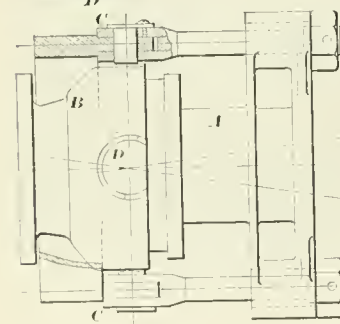

Fig. 2

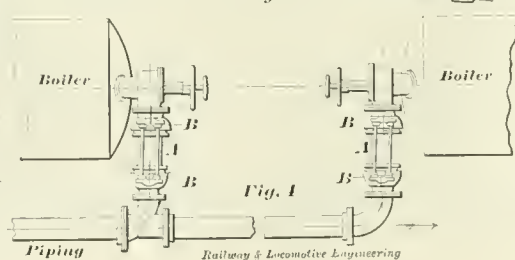

Fig. 4

HARTER'S PATENT BALL JOINT.

center of the ball; hence the ball piece is free to swing in any direction and with a minimum of friction, however high the steam pressure.

Steam tightness is secured by an ordinary stuffing box and gland, as shown, assisted by water grooves cut in a bushing, E; or, if preferred, cut in the socket piece itself. It has been found an easy matter to keep this gland tight with soft packing, as there is always perfect alignment, due to the fact of the working surface being part of a true sphere.

A modification of the above type is shown in Figs. 3 and 4. This is designed to supersede the ordinary telescopic extension joint, and has been used in the British Navy for this purpose on the destroyers Greyhound, Racehorse and Roebuck, and the first-class cruiser, Antrim, recently launch-

ed, a lighter gauge of piping may be used. The universal type is also applicable where temporary connections have to be made for testing stationary engines and other purposes. As the flexibility of this join is unaffected by the pressure, it can be easily designed for hydraulic purposes for any working pressure required.

Standardization.

Some of the non-technical papers throughout the country are inclined to view railroad matters from the fairy godmother standpoint. Not long ago we read that an enormous aggregation of roads under one head was going to have the rolling equipment standardized, and so save lots of money. That is all very well, but no mention was

The Pennsylvania Locomotive Testing Plant at St. Louis.

The Pennsylvania Railroad are going to have a locomotive testing plant at the St. Louis Exhibition this year, and this will be a most interesting exhibit and one which the railroad men of the country will be delighted with. At the close of the St. Louis Exhibition the plant will be transferred to the company's mechanical department headquarters, and will there be made a permanent feature of the Altoona shops.

The plant is being built by William Sellers & Co., Philadelphia, and has been described as being a railroad in itself. It will be a novel sight to see, perhaps, a passenger engine running at full speed, around which you may walk at your leisure, while the fireman shovels

coal and the injectors drain the tank. We have heard an engineer who wished to speak contemptuously of the starting powers of the machine which the master mechanic had assigned to him, say of the engine that he could open the throttle and then get off and walk around her and get on again at the fireman's side before she got anywhere. This gentleman can do the feat before a large audience if he goes to St. Louis, but he will not be an object of interested surprise.

Wants Fair Play for the Compound.

In reply to our Pueblo, Colo., "Fair Play" friend, in regard to Compound vs. Simple Engines, I would state that I do not think the compound should be blamed for the ignorance of the men who is placed there to run her. Ignorance is a very poor excuse, owing to the means that every one has to get a knowledge of the work he has to perform nowadays.

There is a good old saying, "Where there's a will there's a way," and I think that if our brother is very anxious to learn anything about the compound he has got as good an opportunity as any of us firemen or engineers.

How many traveling engineers or others know anything about the simple engine by a knowledge gained by running one; show me a first-class engineer and I will show you a man that has taken advantage of it by study and in this way has gained the point desired.

Let us take, for example, the doctor coming into the sick room; he goes to the patient's side and by feeling the pulse gains a knowledge of the organs inside. He knows what is going on and what is being done by them. The time that that man or doctor has spent in study has given him an insight into the whole subject.

The engineer, if he is a good one, listens to the exhaust of his engine; he can, by running the engine slowly, tell what is going on inside and on which side the trouble is; he then goes on and makes his tests and reports the same.

Why cannot this be done with the compound? It requires study with her as well as with the simple engine. But, remember, when you are running a compound she is not a simple engine.

So, now, my dear brother, I am not a traveling engineer, nor am I as yet running an engine; I am only a common tallow pot; but if I can give you any points on her I will be only too glad to do so, by giving you fair play, and fairer than I have had or got.

Study the engine well; get a good knowledge of her; then if she does not do what you think she ought to do, call on me and I will help you out.

B. J. REINHART.

Susquehanna, Pa.

A Stiff-Backed Car.

The illustration shows the result of failure to properly flag and disobedience of rules in not going back the proper distance. One can hardly comprehend the punishment this steel underframed car received, and then to proudly carry the vanquished to the repair shop without mishap. Nor did the engine fare badly by its terrific onslaught. The ascent was made to the top of the car without other damage than the loss of pilot and engine truck, which were left under the car. This car was built by the Pressed Steel Works of Pittsburgh and weighed 39,000 lbs. Its capacity is 100,000 lbs. and in addition to its 98,000 lbs. of iron with which it was loaded it carried the engine whose weight is 134,000 lbs., making a total

from ten to fifty cars, and the common carrier is given ten days in which to find fifty cars or more.

Failure to live up to this schedule is atoned for by payment of \$25 a day per car for overtime made in the supply of stock cars, but the beautiful part of the law is that the shipper who needlessly holds cars contributes a like amount per day per car. Verily, the "free lunch idea" in car service is fleeing to the mountains, and it is probable that both parties will live happily together ever afterward.

Took Liquid Precautions.

A farmer in Cumberland county was driving across a railroad track when a train killed both his horses and knocked him about ten rods off his course. In

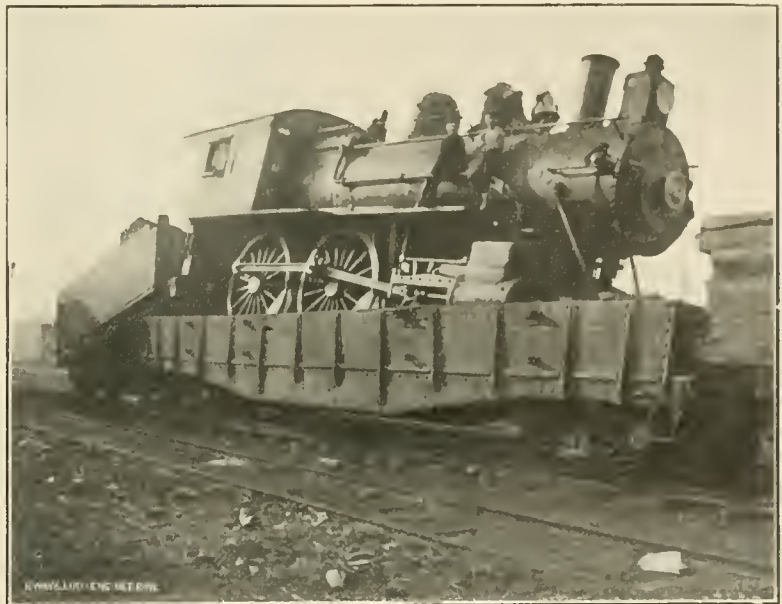

RAPID AND EXTEMPORANEOUS LOADING—CAR NOT LONG ENOUGH TO TAKE THE TENDER.

overweight of 232,000 lbs. of "badly mixed" freight.

Texas Law and Car Supply.

The cattle shippers of Texas are having no trouble in getting stock cars from the railways, if reports from the Lone Star State are correct. It seems that Texas has a law bearing directly on the subject, but, until recently, it had not been taken advantage of by shippers. The law apparently was dead, but now, strange as it may appear, it is being executed, and that is what makes it a live issue.

Railroad companies are, by this law, compelled to furnish cars within a specified time, upon receiving payment in advance of one-fourth of the total freight charge on the proposed shipment. Three days' notice is the legal time given to a railroad to supply ten cars or less. Six days is the limit for

the resulting suit for damages the plaintiff was on the witness stand, making out a good case, when the defendant's lawyer asked him:

"Did you take any precaution before driving upon the track?"

The witness seemed reluctant to answer, but being pressed to do so, finally stammered out:

"Wall, squire, I took a little—just a couple of swallows, that's all."

This started a new line of defense, and it turned out that the couple of swallows were the last in a pint flask that had consoled the honest old farmer along the road. This put a new face on the situation.

Philadelphia papers once were in the habit of boasting about a smart citizen belonging to the town. He was a trunk maker and he had ten sons. He did not train them to his own trade, but got them all employed as train baggagemen.

Vestibule Stock Car.

We are all familiar with the palace horse car; well, now, we have the vestibuled stock car. Mr. W. C. Preston, general freight agent of the Fort Worth & Rio Grande Railway and two others, have lately patented a form of car construction which makes it possible to pass from one car to another through a series of end doors.

The end doors are made so that when swung out at right angles to the car end, the doors strike a stop on next car. Stated more accurately, the door at the A end of one car opens back so as to strike a stop on the B end of the next car ahead, and the door on the B end of the front car strikes a stop on the A end of the car behind it. The doors are so proportioned as to just occupy the space between any two cars when the cars are coupled and the draw gear in its normal state. When the doors are opened back, the passageway is made by a plank platform which is hinged to the end sill of one car and drops down

and the minimum service of yard engine and crew.

Another advantage is that in the event of a car becoming disabled in transit it is possible to quickly unload it by coupling another vestibule stock car to it, and the work can be done without the necessity of taking it to the regular cattle chute at a station. In fact, this kind of transfer operation may be performed anywhere as long as the proper kind of cars are brought together, and, again, the minimum service of yard engine and crew is all that is required.

The obvious lessening in the cost of handling stock to and from cars must make the vestibule stock car a welcome form of vehicle to railroads and to stockmen, though it is just possible that the cattle may in time come to object, as suburbanites do now on an urban trolley line, when confronted with what unreasonable and aggressive newspapers are fond of calling the "car ahead" nuisance.

ings, crossovers and a branch line up the centers. There is a swing bridge, which, by the way, is often used to turn the engine and cars. The rolling equipment consists of two trains, one of which is out of commission, but the train which is used might appropriately be called the *Demonstrator Express*. It is made up of an Atlantic type engine having 5½-in. driving wheels, and cylinders 1½ x 2½ ins. The tender, which is all tank, contains a small electric motor which drives the whole, and the box car behind carries a powerful 5-cell battery specially made for it.

This room and its interesting contents have been arranged by the Union Switch and Signal Company, of which Col. H. G. Prout is general manager, and Mr. J. G. Schrouder is chief engineer. The object of this very narrow gauge little railway is not exactly to afford amusement, though it cannot help doing so, but it is to demonstrate the working of the signal and safety appliances made by this company. The signals, which stand beside the small permanent way, are full sized, though

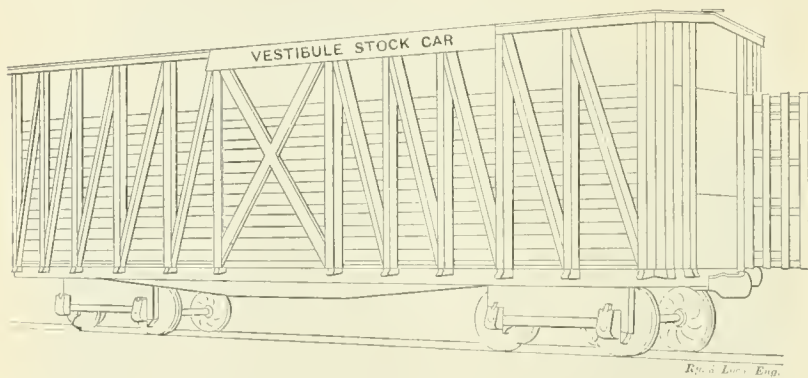

VESTIBULE STOCK CAR—SIDE AND END VIEW.

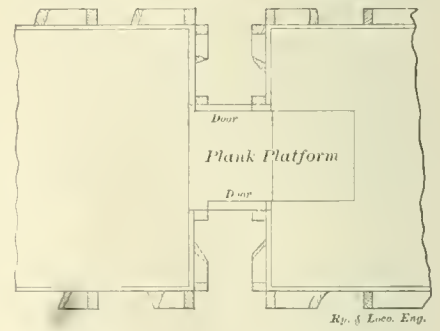

PLAN OF VESTIBULE STOCK CAR.

over the couplers, with the other end resting on the floor of the car ahead. This drop plank platform moves exactly as the draw bridge did over the moat of a baron's castle in the middle ages. There is, of course, only one in each car, for obvious reasons. When the "draw bridge" is down and the doors opened a safe passage from one car to another is made.

The advantage claimed by this form of construction is that a train of twenty-five cars can be loaded in less than one hour, and after the first car has been placed the work can proceed without the services of a yard engine or crew. The loading goes on continuously as the only thing the cattlemen have to do is to make the animals walk through from the first to the last car and take up their positions in it. When the last car is full, its drop plank platform is swung up and bolted and the doors closed, and the loading of the second to last car is proceeded with, and so on, until the entire train is filled. Unloading can be managed in the same expeditious way and with no more labor,

The patentees of this car are Mr. J. L. Pennington and Mr. C. W. Porter, also Mr. W. C. Preston, of the F. W. & R. G., which is a part of the Frisco System. Our illustrations do not show the vestibule car as applied to double-deck stock cars, but there is nothing to prevent their being so equipped.

"A Signal Success."

There is at Swissvale, Pa., a large upper room over an office building owned by an important manufacturing company which place would certainly be called an ideal play room by any intelligent boy with mechanical tastes. The room which is 80 x 65 ft., contains in the center what may be called a counter, standing about the usual height of a table. It is in outline very like a race track, with parallel sides and curved ends. On the counter are two miniature railroad tracks, 4⅞ ins. gauge, with diminutive ties and the daintiest "miniature" rock ballast laid along. The circumference of this "structure" is probably 200 ft., but the total "mileage" of this little railroad is 461 ft., including sid-

carried on posts somewhat shorter than would be used outside. There is an interlocking plant at the "junction" and a road crossing signal and gong placed where a stile on each side of the counter enables persons to cross the tracks. Along the walls of the room are tables containing specimens of electric and signal apparatus both of the past and of the present, a working model of the controlled manual system and a full sized working pneumatic switch with movable frog and detector bar, all complete. The whole equipment not only makes a most modern instruction school, but with its full sized working mechanism, it becomes a demonstrating plant which, it is safe to say, is not surpassed anywhere in the world. It is also a museum in which the evolution of the art of signaling may be traced from crude models of former days up to the instruments of precision which are now available for safe railroad operation.

The electric current which moves the little engine has no connection with wheels or rails and so cannot affect the operation of the semaphores which are arranged with track and with signal circuits just as

in real life. When the little engine goes round its course, which it obligingly does for you at a walking pace, it operates all the signals, causing those behind it to go to "danger" and "caution" and the "clearing" first one then and the other as it moves on. In its trip it passes safely over

tensely practical side to what you see performed on the miniature track. If you listen you can hear the sound of a real express running on one of the four standard tracks below, as a powerful 4-4-2 engine rushes by with ten coaches, filled with men and women who love life as you do.

Old-Fashioned Railroading in Spain.

Old-fashioned methods are still good enough for Spain, and they run their railroad trains in the same way. They usually start them very early in the morning. Four o'clock is the favorite hour, and the hotel man gets you down to the station at least forty minutes in advance, so as to have plenty of time. If you happen to be late, of course, the train will start promptly. If you are down an extra long time in advance it is certain to be held for some mysterious reason.

A few moments before train time the station master tolls a big bell hanging to the wall of the building as a formal notice; a few minutes later a porter in a blue cotton jumper goes up and down the platform ringing a hand bell, which is a warning for people to kiss their friends good-bye again and to get aboard. The conductor of the train blows a horn, which is notice to the engineer and brakemen. Then somebody blows a shrill whistle at one end of the train, which is answered by a similar whistle at the other end, and the guards begin to rush up and down the platform in great excitement slamming the doors of the cars, which open on the sides.

I noticed by the brass plate on the side that the engine was built in Belgium in 1864. It puffed and snorted a good deal, but discharged little smoke, for the fuel is briquettes, a composition of coal, sawdust and glue, which gives no cinders.—William E. Curtis, in the *N. Y. Commercial Advertiser*.



SIGNAL EQUIPMENT EXHIBIT ROOM OF THE UNION SWITCH AND SIGNAL COMPANY, SWISSVALE, PA.

the swing bridge when an "all clear" indication has been given, which would do for a grown-up train. The Union Switch and Signal Company have on exhibition, in this way, all their signal and safety devices, and he would, indeed, be a dull man who could not spend several enjoyable hours in this upper room at Swissville, and go away with some valuable knowledge and an increased respect for the present day quality of human brains.

There is, perhaps, something humorous in watching a tiny locomotive, down whose smoke stack you could just drop a 50-cent piece, moving serenely along, and "protecting" itself by operating large electric and pneumatic semaphores as it passes through "blocks" perhaps a little longer than a park bench. The contrast is heightened by the fact that the proportion between train and signal is such that one of the "protecting" signal blades is large enough to hold both engine and tender. The picture certainly has the humorous element in it, but amusement is not the dominant feeling which it arouses. The room has been set apart for the demonstration of serious work which is done outside on many a crowded road. The exhibit not only renders the gaining of knowledge in this particular case, easy, but it lends a positive fascination to the process, yet all the time the whir and hum of trains on the busy Pennsylvania Railroad, just below the window, remind you that there is an in-

On the real line outside, safety is assured by good track and strong equipment, and assured again by the swing of the signal arms and the click of interlocking latch and bar. The signal bridge which you see from the window is an



"DEMONSTRATOR EXPRESS" NEARING "THE JUNCTION," UNION SWITCH AND SIGNAL COMPANY'S EXHIBIT ROOM AT THE FACTORY.

example of a modern sleepless safety appliance. This wonderful piece of mechanism stands there like the old-time sentinel, and seems to cry to the watcher on the engine, for the sake of the lives behind, "For you the signal system clock has struck the appointed hour, and all's well!"

A car ventilator, which is said to change the air without freezing the passengers in a car, is said to be under trial on the Central Railroad of New Jersey. This is one of the long-felt wants. We hope it may prove successful.

Instruction Car on the New York "L."

Speaking, in 1828, of the spread of popular education, Lord Brougham used

derful precision of the graduating valve action in making service stops.

The various brake cylinders in the car have different lengths of piston travel, and there is a triple valve, purposely made defective, while leaks of all kinds can be artificially produced at any of the six conductor's valves, or at the angle cock at the end of the train line close to where the instructor stands. The brake can, therefore, be operated in good, bad, or indifferent conditions, and corresponding object lessons be impressed upon the minds of those who attend the lectures.

The electric equipment is that for one car and is all inside except the air pumps and the rheostats or resistance coils. The whole set of electrical contactors is

ing intensity of glow or lack of current, the amount of resistance cut in on first contact or cut out as each step up with the controller is made.

The internal mechanism of the controller is shown to students and it may be worked with full current turned on. The action of the master controller auxiliary contact fingers may be seen operated by what is called on the road the "dead man's handle," or the "heart failure button." The device to which these somewhat gruesome terms are applied, has, nevertheless, an important possibility for good beyond the fact that the electric current is automatically cut off should a motorman, for any reason, relax his hold upon the handle. It has the further advantage that when the controller handle is near or at full speed position, if suddenly a quick stop became imperative to avert disaster, the motorman has only to let go the controller handle and apply the brake in the "emergency" and the auxiliary contact device will instantly cut off the current, without the motorman requiring to take even the brief time necessary to turn the controller handle back through its half circle to the zero point. This possibility may mean much in circumstances where seconds count.

There is also a section of the third rail, fully charged, and a contact shoe resting upon it. This is used to explain the method of tying up or insulating a shoe in case of short circuit. The use of fuses and their position in the fuse box can easily be seen in the instruction car.

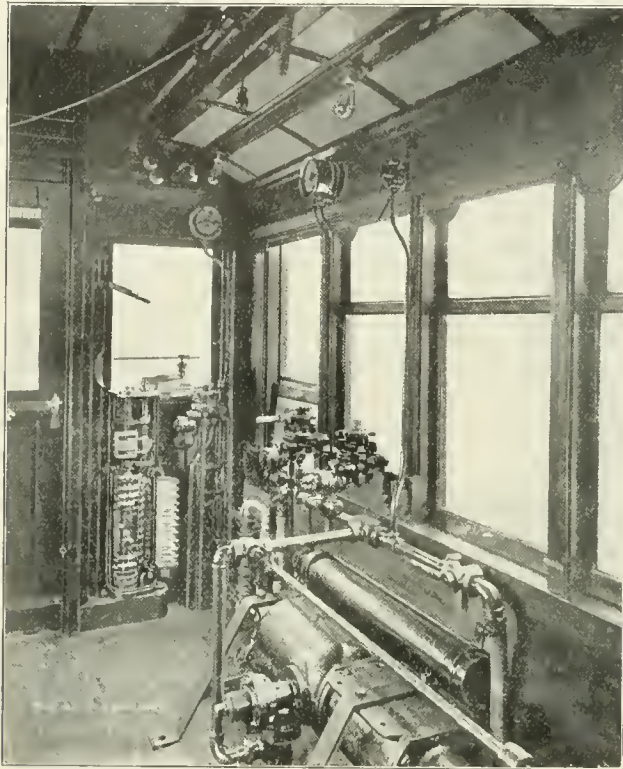

INSTRUCTION CAR ON THE NEW YORK ELEVATED—
CONTROLLER END.

these significant words: "The school-master is abroad, and I trust to him, armed with his primer, against the soldier in full military array." This expression may, in a sense, be paraphrased by saying that on all our progressive railroads today, "the school car is abroad," and as an example of this, the one used on the Manhattan division of the Interborough Rapid Transit System, takes a high place.

We say that this car takes a high place, not because it stands upon the elevated structure in New York City, but because, when compared with other instruction cars, it is found to be well equipped, and to have the unique distinction of being the only one in the country possessing a complete electrical equipment. It is an old Sixth Avenue Car, No. 824, and has been fitted with air hose, piping, auxiliary reservoirs and brake cylinders equal to a train of seven cars. There is not exactly the same amount of piping as would be under seven cars, but the volume of air required to fill that length of piping has been secured by increasing the diameter of the seven "train pipes" in the car.

Attached to one brake cylinder and reservoir is a sectional triple valve working in tandem with the regular one. This shows the exceedingly rapid movements made by the triple piston in "emergency" and "release" and demonstrates the won-

placed upon a rack on one side of the car, and just below is a



INSTRUCTION CAR, NEW YORK "L." AIR AND ELECTRICAL EQUIPMENT.

most ingenious arrangement which consists of a bank of incandescent lamps which show by their vary-

Mr. D. R. Cafferty, an experienced engineer, for many years in the service of the "L," has been given the position of

motor inspector, but he now performs the important duty of instructor, and through his hands all the men employed on the system must pass. The "school car" had been considered by the officials of the Manhattan road, and Superintendent S. D. Smith had advocated its introduction when electrical traction was being taken up. When the Interborough Rapid Transit Company leased the "Elevated," the progressive general superintendent, Mr. Frank Hedley, made the car an actuality. In his former official capacity on the Chicago Elevated road, Mr. Hedley had equipped an instruction room for the men, and he came to New York with full knowledge of the beneficial effects, in railroad operation, which flow from the enlightened policy of intelligent and systematic instruction for those who operate the trains.

Slipping With Steam Shut Off.

The superintendent of motive power of a prominent railroad writes us as follows:

"About a month ago we turned out a 4-wheel connected passenger engine, generally overhauled, with cylinders 19x28, which was built by the Cooke Works about three years ago, and up to the time it went into the shop, had been giving us most excellent service. The engine, after leaving the shop, was run on a freight train for two or three days, and then put on a light passenger train to get thoroughly broken in before being put on one of our heaviest passenger trains.

"In going down into Liberty, a station on our line, running down a grade of about 70 feet to the mile, having run about three miles, the engine bent both side rods and both axles, one of them a new axle 9 ins. in diameter, and the journal 12 ins. long.

"The engineer claimed that the engine started to slip and that he could not prevent it, even by dropping sand on the track, until stopped from defects noted above. I could not believe such a thing could happen, and was not inclined to take the engineer's statement, but my attention has been called to an article in the January, 1893, *LOCOMOTIVE ENGINEERING*, on a similar case. Have you any theory as to the cause?"

We have a theory that the slipping is caused by excess of the counterbalance weights in the driving wheels, but we are unable to follow the action of the disturbing forces. In the years 1892-3 a controversy was carried on by correspondents of *LOCOMOTIVE ENGINEERING* about driving wheels slipping when steam was shut off. No satisfactory explanation of the phenomena was given, but no doubt was left that the slipping sometimes happens, and it was always connected with bent pins or axles. We would like to hear from our readers concerning this.

The Development of the Eight-Wheel Connected Engine on the Baltimore & Ohio Railroad.

BY J. SNOWDEN BELL.

The necessity, under the conditions of its service, of obtaining increased tractive force by increasing the weight of locomotive engines and distributing it over a greater number of driving wheels, was recognized at an early date in the history of the Baltimore & Ohio R. R.

R. R. were of the class designed and built by Ross Winans and familiarly known as "Mud Diggers." As shown by the report of the machinery department of the road for 1859, there were then in service, six of these engines, the "Buffalo" No. 35, "Baltimore" No. 36, "Cumberland" No. 37, "Elk" No. 41, "Tuscarora" No. 45 and "Allegheny" No. 46. The writer believes that original Nos. 33 and 34, "Hercules" and "Gladia-

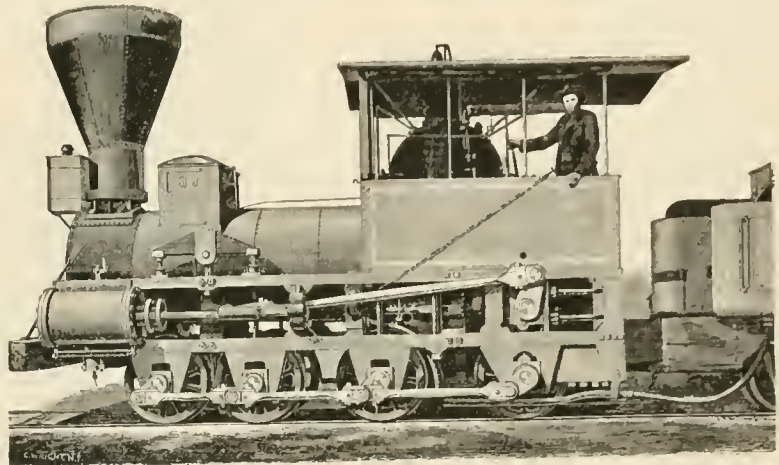

THE MUD DIGGER

and except as to a single and unsuccessfully experimental instance, that of three locomotives built for the Western R. R. of Massachusetts, from the designs of Ross Winans, it is probable that engines having eight connected driving wheels were first built for and operated on the Baltimore & Ohio. The first of these engines which were used on that road was built by Ross Winans and was placed on the road in 1844, and the first

tor," were also "mud diggers." No drawings of these engines are now extant, but their construction will be readily understood from the accompanying illustration which is a reduced reproduction of a photograph of No. 37, taken at Mount Clare shops in 1863.

The cylinders were 17 inches in diameter and 24 stroke, and the main connecting rods were coupled to cranks on a shaft extending across the frames in the

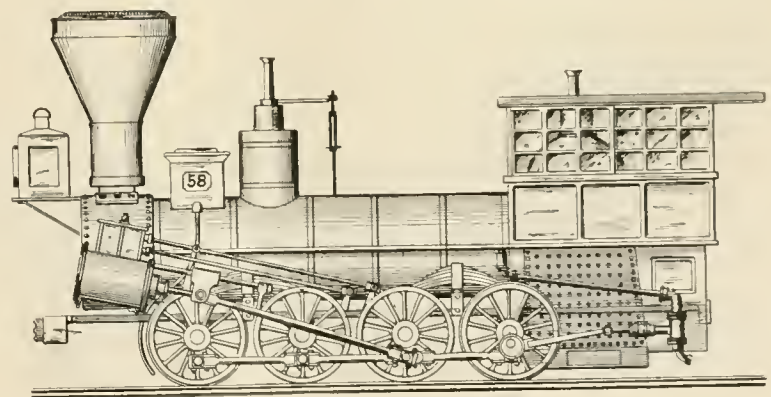

THE DRAGON CLASS.

of the type (except the experimental engines referred to) which were built by M. W. Baldwin, were a lot of seventeen, constructed by him for the Philadelphia & Reading R. R. in 1846. It is not likely that an engine of this type was produced by any other of the few less prominent locomotive builders of that period.

The eight-wheel connected engines first placed on the Baltimore & Ohio

rear of the fire box and geared by spur wheels to the back driving axle. The driving wheels were 33 inches in diameter and the driving axles carried end cranks which were coupled by side rods. As the main and side rods moved in opposite directions, by reason of the interposed gearing, the engines presented an odd appearance when running.

The "mud diggers" were built at dif-

ferent dates, from October, 1844, to December, 1846, and some of them were in yard service as late as 1865 and possibly afterward. A number of their cylinders and main connections were used as stationary engines in the shops of the road after their road service was terminated.

The Field Columbian Museum at Chicago contains a full size wooden model which is stated to represent an engine called the "Mount Clare," built at the

larger and of modified form, were built by M. W. Baldwin, as the result of an advertisement for proposals which was published by the Baltimore & Ohio R. R. Co. in the *American Railroad Journal*, of October 23, 1847. As indicative of the supposed requirements of a heavy freight locomotive of that day, this advertisement may be found of interest, and is as follows:

"To Locomotive Engine Builders:

there shall be not less than one-fifteenth in the fire box.

7. The tubes of No. 11 flue iron, with not less than $\frac{3}{4}$ of an inch space between them in the tube sheets.

8. The fire box with the exception of the tube and crown sheets to be of $\frac{3}{8}$ in. copper.

9. The tube sheets to be $\frac{3}{8}$ in. thick.

10. The boiler to be of No. 3 iron, of the best quality.

11. The fire box to be not less than 24 ins. deep below the cylindrical part of the boiler.

12. The steam to be taken to the cylinder from a separate dome on the fore part of the boiler.

13. The frame, including the pedestals, to be entirely of wrought iron, and the boiler to be connected therewith, so as to allow of contraction and expansion without strain on either.

14. The cylinders to be 22 in. stroke, and not less than 17 ins. diameter.

15. The cut off to be effected by a double valve, worked by separate eccentrics.

16. The angle of the cylinder to be not greater than $13\frac{1}{2}$ degrees with the horizontal line.

17. The frame and bearings to be inside the wheels and the direction from the cylinder direct with the back pair of intermediate wheels.

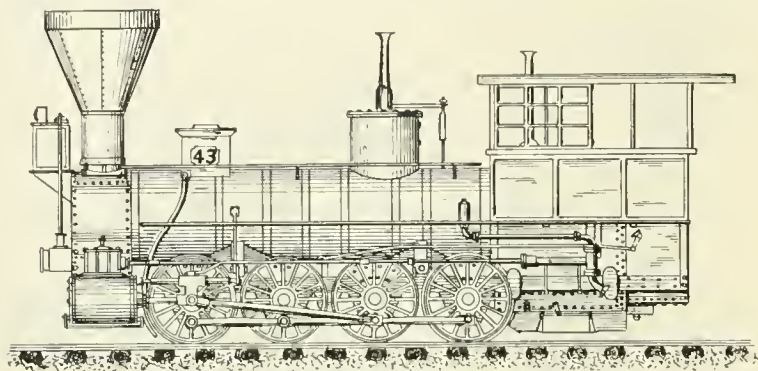

BALTIMORE & OHIO EIGHT-WHEEL ENGINE.

B. & O. R. R. shops of that name in Baltimore, in 1845. This model shows an eight-wheel connected engine, having inside cylinders operating a shaft located above and between the vertical planes of the second and third driving axles, which shaft, through spur gearing, rotated a countershaft in the horizontal plane of the driving axles. The countershaft and the driving axles all have end cranks which are coupled by side rods.

No authentic information as to this engine is obtainable, and while it is probable that the model referred to correctly indicates the general design of the machine, its accuracy as to detail is questionable. The model shows a taper stack, "fish horn" dome cover, and cab, all of much more modern date than 1845, and having been made from the recollection of a very aged man, its showing of other structural particulars is doubtless more or less imaginative. The inferiority of the design to that of the "mud digger" is so manifest that it was probably immediately recognized, as no more were built.

The class of engines of the type under consideration which next followed the "mud digger" was that built by M. W. Baldwin, having inclined cylinders, independent cut-off valves, and what was known as the Baldwin "flexible beam truck," carrying the bearings of the front and second driving axles. The first of these, the "Dragon," No. 51, was placed on the road in January, 1848. This engine had cylinders $14\frac{1}{2} \times 18$ ins., driving wheels 43 ins., 108 tubes in boiler, and weighed 41,000 pounds. It was equipped with a six-wheel tender having a water capacity of 1,200 gallons.

Four more engines of this type, but

Proposals under seal will be received by the undersigned up to Saturday, the 6th of November, inclusive, for furnishing the Baltimore & Ohio Railroad Co. with four locomotive engines, in conformity with the following specification:

1. The weight not to exceed 20 tons,

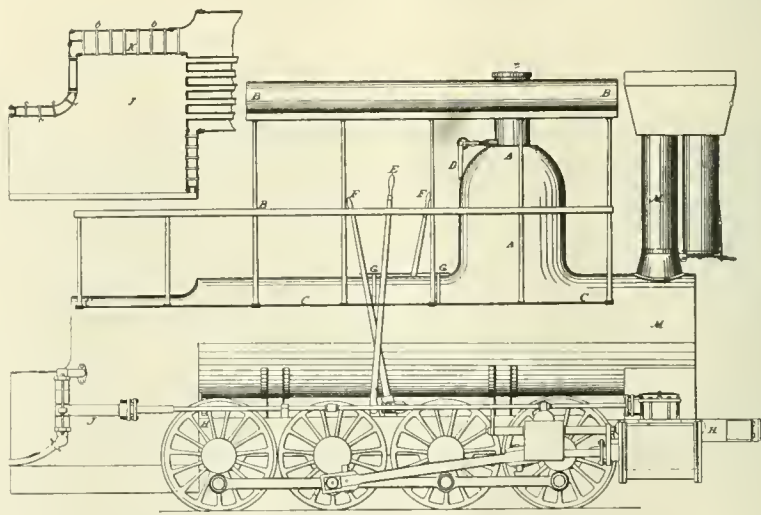

FIRST CAMELS.

of 2,240 lbs., and to come as near to that limit as possible.

2. The weight to be uniformly distributed upon all the wheels, when the engine is drawing her heaviest load.

3. The number of wheels to be eight.

4. The diameter of the wheels to be 43 inches.

5. The four intermediate wheels to be without flanges.

6. The boiler to contain not less than 1,000 square feet of fire surface, of which

18. The centers of the extreme wheels to be not more than $11\frac{1}{2}$ feet apart.

19. The wheels to be of cast iron with chilled tire.

20. The means to be provided of varying the power of the exhaust in the blast pipe.

21. The engine to be warranted to do full work with Cumberland or other bituminous coal, in a raw state, as the fuel—and the furnace to be provided with an upper and lower fire door with that view.

22. The smoke stack to be provided with a wire gauze covering.

23. Two safety valves to be placed upon the boiler, each containing not less than 5 square inches of surface and one to be out of the reach of the engine man.

24. The tender to be upon 8 wheels and constructed upon such plan as shall be furnished by the company, and to carry not less than 3 cords of wood or its

with old sketches and others made from Engine No. 57, which is now in the Field Museum, Chicago, but has been altered in several particulars.

The records are meager as to these engines, but their cylinders are known to have been 17x22 ins., and their driving wheels 43 ins., as specified in the advertisement. Their weight exceeded that specified, being at first about 52,000

good work on the heavy grade in Howard street.

The engines "Saturn," No. 56, built by the New Castle Manufacturing Company, in June, 1848, and Nos. 54, 63 and 64, built by the company in 1848, 1849 and 1850, were of the same general construction as those last referred to, and after these, no more of this class were built for the B. & O. R. R.

The next class of eight-wheel connected engines which was introduced on the road was known as the "Company's eight-wheel engine," and is shown in the accompanying reproduction of an old hand sketch of No. 43, made by the writer. They were Nos. 33, 34, 38, 40, 43, 49, 67, 72, 76, 83 and 131, and were built at different dates from October, 1850, to November, 1853. Nos. 67, 72 and 83 had cylinders 20x22, and the others 19x22; the driving wheels of all of them were 43 inches. A report of their performance will be found in *Colburn's Locomotive Engineering*, page 83, which gives the following particulars of the engines: Weight, 57,400 lbs.; fire-box heating surface, 87.5 sq. ft.; tube heating surface, 984 sq. ft.; total heating surface, 1,071.5 sq. ft.; number of tubes, 134; diameter, 2 in.; length, 14 ft.

These were the first *direct connected* engines of the type in which the cylinders were set horizontally, and they were bolted to a flat-sided smoke box, the bed plate or saddle not being then known. The valves were worked by drop-hook gear, which required connections, as shown, for starting bars.

The next, and up to 1874, the most ex-

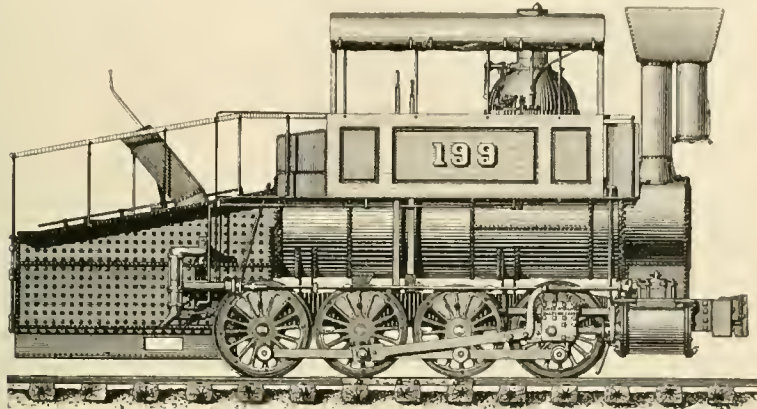

LAST OF THE CAMELS.

equivalent in coal, and 1,500 gallons of water.

25. The materials and workmanship to be of the best quality, and the engine to be subjected to a trial of 30 days' steady work with freight upon the road, before acceptance by the company.

Payment to be made in cash on the acceptance of the engine. The four engines to be delivered at the company's Mount Clare depot, in Baltimore—the first on the 1st of February, 1848, and the three others on the 1st of March, April and May ensuing.

The track is 4 ft. 8½ in. gauge, and the shortest curve of the road is 400 feet radius.

The company to be secured against all patent claims.

Further information will be communicated upon application to the undersigned, at the company's office, No. 23 Hanover street, Baltimore, to which the proposals suitably indorsed will be addressed.

By order of the President and Directors.

BENJ. H. LATROBE,

Chief Engineer and General Superintendent.

Baltimore, Sept. 18, 1847."

The contract for the engines called for by the above advertisement was awarded to M. W. Baldwin, and the four engines built under it were the "Memnon," No. 57, October, 1848; "Hector," No. 58, and "Cossack," No. 60, December, 1848, and "Tartar," No. 62, January, 1849. The illustration of No. 58, which is here presented, was prepared from the recollection of the writer, in connection

pounds, and was reduced by change to about 47,000 pounds. All the driving boxes were in pedestals in the main frame, the Baldwin flexible beam truck not being used. The second and third pairs of wheels were not flanged, and the axles were closely set to conform to the required limitation of wheel base. The fire box was of rectangular section, and the back wall was rearwardly inclined

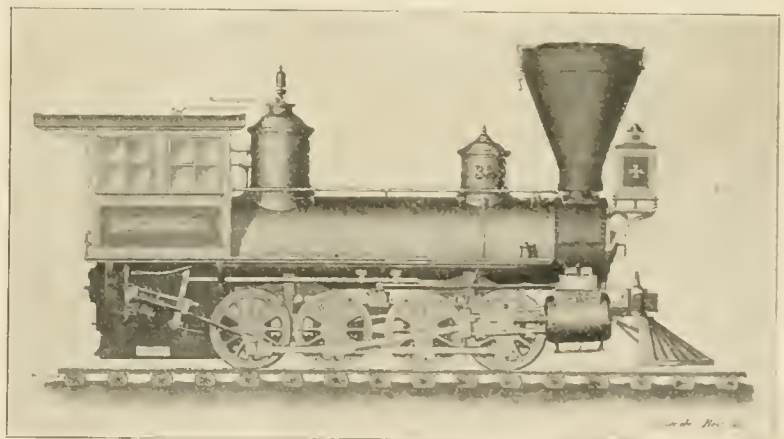

PERKINS EIGHT-WHEEL ENGINE.

from top to bottom, so as to provide a larger grate, and had upper and lower fire doors. As early at least as 1858, these engines had half-stroke pumps worked from the crank pins of the rear axle, as shown in the illustration, but they may have been built with cross-head pumps. One of the engines was used in hauling freight cars between Camden Station and Bolton, in Baltimore, and did

tended application to service of the eight-wheel connected engine, was that of the camel engines of Ross Winans. These have been so frequently and fully described and illustrated in technical publications that it will suffice here to merely note that there were three classes of them, the "short," "medium" and "long" furnace camels, all having cylinders 19x22, and 43 in. driving wheels, and not

varying to any extent, except as to the shape and size of fire box.

The first of this class, the "Camel," No. 55, was placed on the road in June, 1848, and corresponded in all essential particulars with the accompanying illustration. The cylinders of this engine were 17x22, and the writer believes that it was the only camel of the "short" furnace type, and the only one having cylinders smaller than 19 inches, which the road ever had.

Up to 1863, one hundred and twenty camel engines had been put in service on the Baltimore & Ohio R. R., and the last one, No. 219, was built in February, 1857, soon after which a controversy arose between Ross Winans and Henry Tyson, then master of machinery, as to the relative merits of the camel and the six-coupled ten-wheel engine, the result of which appears to have been a cessation of orders for engines of the former class by the company. In 1863, the company being pressed for additional motive power, bought, at a high figure, three

Perkins engines as compared with the camels, may be noted their larger and more strongly constructed boilers, the use of heavy and substantial bar frames instead of plate frames, round smoke boxes with a saddle or bed plate connection to the frames and cylinders, draw bars connected directly to the frames, and stationary link valve motions.

The general dimensions of these engines were as follows:

Weight of engine (empty), 65,000 lbs.; weight of tender, 23,000 lbs.; steam pressure, 100 to 110 lbs. Cylinders, 19½ x 22 ins.; driving wheels, 43 ins. Boiler diameter, 48¾ ins.; boiler thickness, ¾ in. Flues, number, 115; dia. outside (No. 12 W. G.), 2½ ins; lgth., 15 ft.; flue sheet (copper), ⅝ in. Fire box, length, 66 ins.; width, 42 ins.; depth, 57 ins.; grate area, 19.25 sq. ft. Back sheet (copper), ⅜ in.; side sheets (for 36) ⅝ ins. from bottom, copper, ⅜ in. Exhaust nozzle, 4½ ins.; ten. water cap., 2,140 gals.

The Perkins engines were the last class of eight-wheel connected engines, without leading trucks, which were used on the Baltimore & Ohio R. R., and the consolidation or 2-8-0 type was adopted as the standard for heavy freight service

trated, and presents an interesting comparison, not merely with the original "mud digger," but also with the several improved designs succeeding it which have been referred to and which mark distinct stages of improvement in design and capacity.

The leading dimensions of the I 7 class engines are as follows: Weight, 193,500 lbs.; weight on driving wheels, 173,000 lbs.; cylinders, 22x28 ins.; diameter of driving wheels, 56 ins.; diameter of boiler outside smallest course, 71 ins.; total heating surface, 2,828 sq. ft.; Belpaire fire box, grate area, 49 sq. ft.

The long lapse of time since the construction of the earlier engines which are referred to, and the absence of full records regarding them, render it probable that errors of detail may be found in the foregoing review of them. It is, however, believed to be correct in all substantial particulars and may perhaps lead to further and fuller information upon the subject from some of the few now living who have practical experience, at early dates in connection with the mechanical department of the Baltimore & Ohio Railroad.

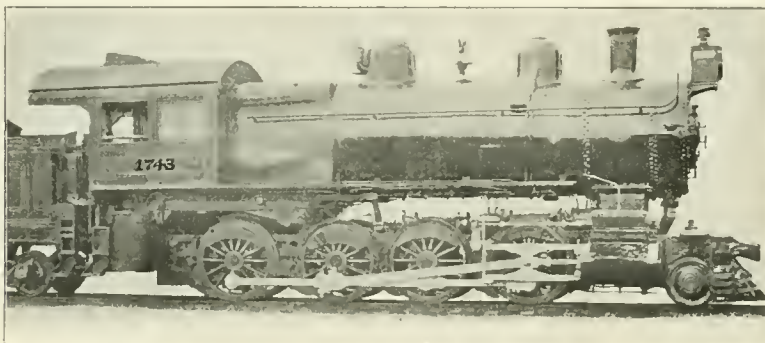

LATEST B. & O. EIGHT-WHEEL CONNECTED ENGINE.

long furnace camels which had been in Winans' shop since 1860, one of which, No. 199, is here shown, and no more of this class were thereafter built.

In 1865, Thatcher Perkins, then master of machinery of the company, designed a new class of eight-wheel connected engine, in which he discarded those features of the camel engines which had been shown in service to be objectionable, and retained their useful ones in modernized and improved form. Twenty-seven of these engines were placed on the road, and the first one, No. 32 (afterward 83), was built at Mount Clare shops in 1865. Of the others of the lot, 20 were built by the Grant Locomotive Works, Paterson, N. J.—2 by Reaney, Son & Archbold, Chester, Pa., and 4 by the company. They were generally known as "greenbacks," as the Grant engines were painted that color and looked very well in it. The illustration is a reduced reproduction of a drawing made carefully to scale in all details, by the writer.

Among the improved features of the

about 1874, when a number of these engines were built for the road by the Danforth Locomotive & Machine Co., as well as by the B. & O. R. R. Co. in its Mount Clare shops. These engines were amongst the heaviest of those constructed at that period, weighing 96,550 lbs., and had cylinder of the then usual dimensions of 20x24 ins. and 50 in. driving wheels. The engines of this type which were from time to time subsequently obtained by the road, accorded with the general increase which was made in weight and dimensions, and include a number of compounds of different constructions. The present standard eight-wheel connected engine, which is that known as the I 7 class, and is of the simple or single expansion type, embodies the leading features of the most recent and approved practice, prominent among which is a medium width fire box, giving sufficient grate area for free steaming with the grades of bituminous coal which are used. One of this class, built by the Pittsburgh Works of the American Locomotive Co., is here illus-

Principal Electric Units.

There are certain electrical units that every intelligent man ought to commit to memory and retain as closely as he does the multiplication table. They are:

The Volt, which represents pressure, the same as a head of water does, is about equal to the electro-motive force of one Daniells cell, or, to be exact, a Daniells cell is 1.07 volts.

The Ampere represents the rate of flow of electricity. It is the measure of the current produced by an electro-motive force of one volt through a resistance of one ohm.

The Ohm is the resistance of column of mercury one square millimeter of cross-section area and 106.24 centimeters long. An ordinary copper trolley wire of No. 0 American wire gauge with a diameter of 0.325 in. offers a resistance of one ohm for two miles of length.

The Watt is the rate of work represented by a current of one ampere urged by one volt of electro-motive force—the volt ampere: 746 watts represent one electric horse power.

The most valuable workman is he who understands just how well to do a job and does it from the common-sense standpoint. It is a mistake to suppose that a job cannot be too well done. Time spent on superfluous finish is wasted.

The American Locomotive Company are building at Schenectady a tandem compound for the Cape Government, of South Africa, being a duplicate of one built some time ago.

Heavy Consolidation for the L. S. & M. S.

We illustrate here an example of heavy freight power recently bought by the Lake Shore & Michigan Southern Railway. It is a consolidation, or 2-8-0 engine, built at the Brooks works of the American Locomotive Company, and it weighs, in working order, 235,400 lbs. This makes engine No. 1000 a good second to the 2-10-2 Vauclain compound belonging to the Santa Fe. That engine, which we illustrated in our November, 1903, issue, weighs about 143 tons, and this Lake Shore engine is a little more than 117 tons.

The cylinders are 23x30 ins., simple, the drivers are 57 ins. in diameter, the steam pressure is 200 lbs., and the calculated tractive effort is 47,300 lbs. The weight on the driving wheels is 207,000 lbs., and the ratio of tractive power to adhesive

inside. The visible stack is 22 ins. high, while the portion out of sight is 24½ ins. long; it is flared out to about 28 ins. and rests upon the netting. The stack is really a taper stack, but the choak is about 8 ins. below the level of smoke box top and is 20 ins. in diameter. The top of the stack, which is 24 ins. diameter, stands 15 ft. 2½ ins. from the rail. The dome and sand box are flattened and the cab roof is close to the boiler, so that the whole engine is evidently near what our friends in England would call the loading gauge limit for bridges and tunnels.

The boiler is of the straight top type and measures 80 ins. diameter at the smoke box end. The center of the boiler is 9 ft. 11 ins. from top of rail. The fire box has a heating surface of 203 sq. ft. with a grate area of 55 sq. ft. The tubes, which are 460 in number, give 3,725 sq. ft. of heating surface, and the total is

binder when turned, moves the wedge up or down. There are, of course, many Brooks details about the engine. The whole design is pleasing and though the machine is heavy, it is not clumsy in ap-



PEDESTAL BRACE.

pearance. Mr. F. H. Ball is superintendent of motive power of the Lake Shore road.

GENERAL DIMENSIONS.

Weight in working order, 235,400 lbs.; weight on drivers, 207,000 lbs.; weight eng. and ten. in work'g order, 386,400 lbs.; wheel base, driving, 17 ft. 3 ins.; wheel base, total, 26 ft. 5 ins.; wheel base, total, eng. and ten., 57 ft. 10 ins. Wheels, etc.—Dia. of driving wheels, outside of tire, 57 ins.; dia. and length of driving journals,

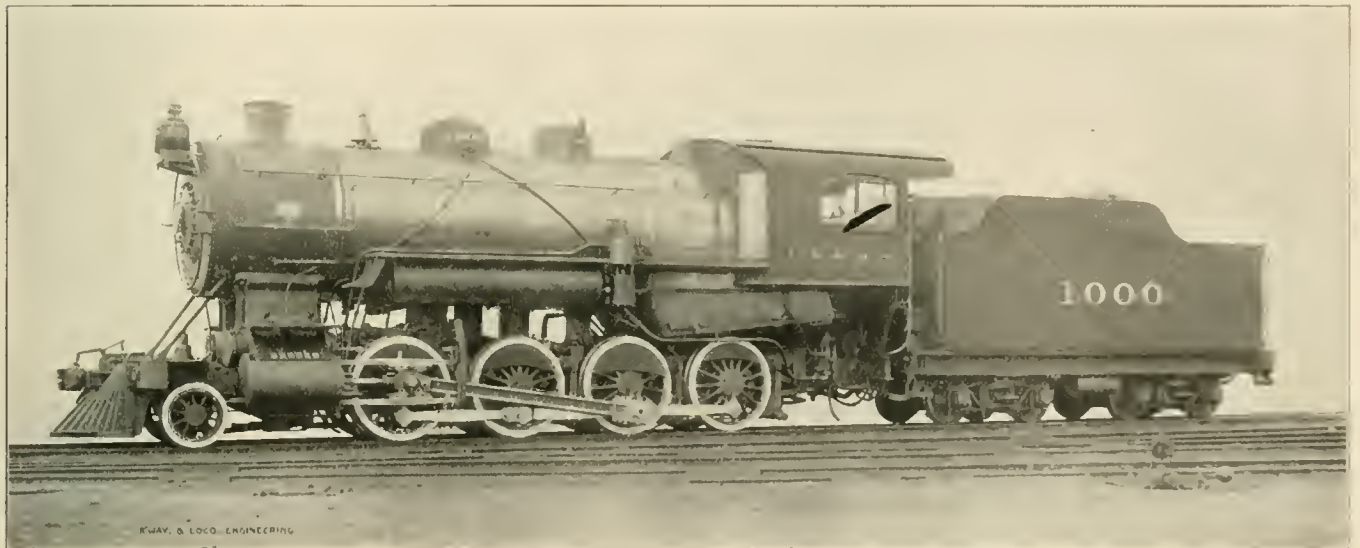

HEAVY CONSOLIDATION ENGINE FOR THE LAKE SHORE.

weight is as 1 is to 4.37. All the wheels are flanged, and the main drivers are the third pair. The valve motion is direct, with almost straight transmission bar passing over the second driving axle. The valve is of the piston type, 12 ins. in diameter, with maximum travel of 5 7/16 ins.

The weight of the engine is carried on springs placed between the frame bars and between the wheels with the exception of the leading pair, which is equalized with the pony truck, and has its springs over the driving box. The brackets which support the yoke and rocker boxes also take the back ends of the leading driving springs. There is a bracket carried on the frame on each side placed just below the cross equalizer bar for front truck. In case the leading spring becomes weak or if a back hanger breaks, the cross equalizer bar would then rest upon these brackets, and so prevent the back end of the truck equalizer dropping down.

The smoke box arrangement is such that more than half the smoke stack is

3,957 sq. ft. The water tubes give 29 sq. ft. The blow-off cock is placed in the bottom of the first boiler course close to the smoke box, and just back of the blow-off cock is placed the injector connection through which the boiler is fed. This casting receives the delivery pipes from both injectors and inside the boiler a flat spreading elbow directs the flow of water toward the fire box. In this way, while the injector is working, there is a constant movement of cooler water along the bottom of the boiler towards the most effective heating surface.

There are several interesting features about this engine; the main reservoirs are carried under the running board and the driver brake cylinder is between the frames and close to the smoke arch. The pedestal binders are steel made with a lug which comes down far enough to just hold a nut on the wedge bolt stem between binder and lug. Two check nuts hold the wedge in place, and when these are slacked off the nut between lug and

9 1/4 and 10 ins. in dia. x 12 ins.; dia. and length of main crank-pin journals, 7 1/2 ins. x 7 ins.; dia. and length of side rod crank pin journals, 5 1/2 ins. in dia. x 5 1/2 ins.; dia. of engine truck wheels, 33 1/2 ins.

Boiler—Working pressure, 200 lbs.; fire box, length, 109 ins.; width, 74 ins.; depth, front, 83 1/2 ins.; back, 69 1/2 ins.; water space, front, 4 1/2 ins.; sides, 4 1/2 ins.; back, 4 1/2 ins.; tubes, length over tube sheets, 15 ft. 6 1/2 ins.; fire brick, supported on, four 3 in. tubes.

Heating surface—Tubes, 3,725 sq. ft.; water tubes, 29 sq. ft.; fire box, 203 sq. ft.; total, 3,957 sq. ft.

Tender—Weight, empty, 56,580 lbs.; wheels, dia., 33 ins.; journals, dia. and length, 5 1/2 in. dia. x 10 ins.; wheel base, 18 ft. 0 ins.

The Newton and North Western Railroad Co., with headquarters in Boone, Ia., it is understood will shortly place an order for two new modern passenger engines. The 102 miles of their road is practically completed, and their right of way purchased through the city of Boone. They are now grading through that city. They recently purchased 25 gondolas from F. M. Hicks, Chicago.

Of Personal Interest.

Mr. J. E. O'Brien has been appointed master mechanic at Fargo, N. D., on the Northern Pacific Railway, vice Mr. T. J. Cutler, transferred.

Mr. J. Langley has been appointed assistant master mechanic of the Oregon Railroad & Navigation Company, with headquarters at Albina, Ore.

Mr. F. C. Cleaver has been appointed superintendent of motive power and rolling stock of the Rutland Railroad, vice Mr. P. T. Lonergan, resigned.

Mr. S. J. Hungerford has resumed his duties as master mechanic of the Western Division of the Canadian Pacific Railway. His office is at Calgary, Alta.

Mr. James E. Young has been appointed road foreman of engines, Second District, Canadian Pacific Railway, with headquarters at White River, Ont.

Mr. C. W. Lee, master mechanic of the Norfolk division of the Southern Railway, has been transferred to Greensboro, on the same road, in the same capacity.

M. W. F. Buck, formerly master mechanic on the Northern Pacific Railway, at Missoula, Mont., has resigned his position to accept a similar position in California.

Mr. J. A. Hazleton has been appointed chief clerk in the office of Mr. W. C. Loree, general superintendent of the Baltimore & Ohio, with headquarters at Pittsburgh, Pa.

Mr. J. D. Weaver has been appointed roundhouse foreman on the Pittsburgh, Cincinnati, Chicago & St. Louis, with office at Bradford, O., vice Mr. Altbater, transferred.

Mr. J. C. Stuart, general superintendent on the Erie, at Cleveland, has been promoted to the position of general manager of the same road, with headquarters in New York.

Mr. W. W. Hoffman, a machinist of much ability, who formerly worked at Council Bluffs, has been appointed night foreman, at Carroll, to succeed Mr. H. B. Jones, promoted.

Mr. James McDonough has been appointed master mechanic of the El Paso Division of the Chicago, Rock Island & Pacific, at Dalhart, Tex., vice Mr. W. W. Leeman, transferred.

Mr. T. J. Cutler, master mechanic on the Northern Pacific, at Fargo, N. D., has been transferred to a similar position at Missoula, Mont., on the same road, vice Mr. W. F. Buck, resigned.

Mr. G. N. Hawson, general foreman of the Southern Railway, Greensboro, N. C., has been promoted to be master mechanic at Sheffield, Ala., vice Mr. J. J. Bailey, transferred to the Norfolk division.

Mr. J. J. Walsh has been transferred from the Dennison, O., shops of the Pittsburgh, Cincinnati, Chicago & St. Louis, and has been put in charge of the same company's shops on the Toledo Division.

Mr. J. J. Williams has been appointed general foreman of the locomotive department in the shops of the Pittsburgh, Cincinnati, Chicago & St. Louis, which are situated at Dennison, Ohio., vice Mr. J. J. Walsh, transferred.

Mr. Benjamin McKeen has been appointed general manager of the Vandalia Line, with headquarters in St. Louis. Mr. McKeen has spent all his working life on the Vandalia line, and his father was president of the road for many years.

Mr. Joseph Osborne, formerly roundhouse foreman at Saratoga Springs, N. Y., on the Delaware & Hudson Railroad, has been appointed master mechanic on the same road, with office at Green Island, vice Mr. A. Buchanan, Jr., resigned.

Mr. W. W. Leeman, formerly master mechanic on the Chicago, Rock Island & Pacific Railway, at Dalhart, Tex., has been appointed master mechanic on the same road, with headquarters at Goodland, Kan., vice Mr. W. E. Anderson, resigned.

Mr. O. B. Altbater, who has been until recently foreman of the roundhouse at Bradford, O., on the Pittsburgh, Cincinnati, Chicago & St. Louis, has been appointed foreman of the Indianapolis shops on the same railroad, vice Mr. E. B. Hunt, transferred.

Mr. H. McCourt has been advanced to the position of assistant general superintendent of the lines south of the Ohio river belonging to the Illinois Central, with headquarters at Memphis, Tenn. Mr. McCourt has been particularly successful in keeping trains moving on congested regions.

Charles A. Hino, of Buffalo, has been appointed general foreman of the Lackawanna shops at Elmira, as the successor to Donald W. Jackson. For the past seventeen years Mr. Hino has been filling positions in the mechanical department of the Lake Shore & Lackawanna shops.

Mr. Thomas J. McPherson, formerly general foreman on the Chicago &

Northwestern, at Eagle Grove, Iowa, has been advanced to the position of roundhouse foreman, 40th street, Chicago, with the same company. He will have charge of a very important point on the Northwestern system.

Mr. E. G. Bryant has been appointed division foreman on the International & Great Northern, at Mart, Tex., vice Mr. W. C. Burel, resigned. Mr. Chas. Bean succeeds Mr. Bryant as roundhouse foreman at Palestine. Mr. R. J. Long has been appointed foreman of blacksmith shop at Mart, Tex.

Mr. W. L. Tracy, formerly master mechanic E. T. V. & G. & Southern R. R., Atlanta, Ga., has been appointed master mechanic of the Louisville & Nashville, headquarters Louisville, Ky. Mr. Tracy's long experience as a master mechanic eminently fits him for the mechanical duties which have now been assigned him.

Mr. John D. Matheson, who so ably filled the position of traveling engineer on the Oregon Railway & Navigation lines in Oregon and Washington, has been promoted to be general foreman on the same road, with headquarters at La Grande. He has charge of the Mountain Divisions, between Huntington and Umatilla.

Mr. Charles H. Hines has been appointed electrical engineer of the Canadian Pacific Railway, with office at headquarters. This is a position just created. Mr. Hines will have general supervision over all electrical matters, including power and lighting, generators, motors, etc. He will report to the superintendent of rolling stock.

Mr. Gordon H. Wills, formerly foreman of the motive power and car departments of the Northwestern at Carroll, Iowa, has been promoted to the position of foreman at Council Bluffs, to succeed Mr. Shadle, transferred, and Mr. H. B. Jones, night foreman at Carroll, has been advanced to the vacancy created by the promotion of Mr. Wills.

Mr. W. J. Shadle, formerly foreman of the motive power and car departments of the Chicago & Northwestern Railway at Council Bluffs, has been promoted to the position of general foreman with the same company, at Clinton, Iowa, to succeed Mr. Chas. Markel, who has been made foreman of the machine shops of the Northwestern at Clinton.

Mr. J. Mullany, the mechanical expert and master mechanic in the machine tool shop of the American Locomotive Company's shops at Schenec-

tady, N. Y., has resigned that position to accept one with the Wheeler Condensing Engine Company, of Kortright, N. Y. The shop force presented him with a beautifully carved meerschau pipe and a Morris chair as a mark of esteem and regard.

Mr. W. G. Wallace, whose departure from the Chicago & Northwestern was mentioned in our personal column last month, was recipient of a handsome diamond ring and diamond pin, given to him as a mark of esteem by the employees of the motive power department of the road, with which he had been so long connected. Mr. Wallace has accepted the position of master mechanic on the Duluth, Missabe & Northern Railway.

Mr. Willis C. Squire, mechanical engineer, has been elected vice-president of the Locomotive Appliance Company, with offices at 1614, 1615 and 1616 Chemical Building, St. Louis, Mo. Mr. Squire is well known as mechanical engineer for the Frisco System, and previous to that, as engineer of tests for the Santa Fe System. His large experience in railroad and locomotive work especially fits him for the business in which he is now engaged.

Mr. H. F. J. Porter, who has been associated with Westinghouse interests since the first of the year, and has held the position of assistant manager of the Publishing Department, with offices in East Pittsburgh, and 10 Bridge street, New York, has been made second vice-president of the Nernst Lamp Company, of which enterprise Mr. George Westinghouse is president, with the duties of general manager and headquarters at Pittsburgh. He assumed charge on December 1. This appointment does not affect Mr. Porter's relations with the Publishing Department at the present time.

Mr. Webb C. Ball has been appointed general time inspector of the Illinois Central Railroad, and also on the Yazoo & Mississippi Valley Railroad, vice Mr. J. W. Forsinger, resigned. Beginning with the local inspectorship for the Lake Shore & Michigan Southern Railway, Mr. Ball has conducted the work of time inspector in a manner which has won him the confidence of officials and employees alike. The New York Central, the Lake Shore, the Big Four, the Michigan Central, and all the other lines of the Vanderbilt System, the New York, Ontario & Western, the Illinois Central, and part of the 'Frisco System, are under his jurisdiction.

Mr. Archibald Buchanan, Jr., was recently presented by the employees of the Delaware & Hudson shops at Green Island with a beautiful solid silver tea set, as a slight token of the esteem in which he is held by his official subordinates. Mr. Buchanan, who

has, until now, been master mechanic on the Delaware & Hudson Railroad, goes to the Central Vermont Railroad, where he will assume the duties of superintendent of motive power and rolling stock. The tea service is a beautiful example of the silversmith's art, handsomely chased and engraved with Mr. Buchanan's monogram. The recipient of the gift made a brief but characteristically happy response to the presentation speech.

Mr. Jacob Johann, the veteran master mechanic, who is living in comfortable retirement in Springfield, Ill., has supplied considerable useful information to Mr. Sinclair concerning pioneer locomotives. Mr. Johann was an apprentice in the Norris Locomotive Works when the "John Stevens," illustrated in our December number, was built and accompanied the engine to Burlington, N. J., when it was taken there to be delivered. On that occasion he received his first pass, which was to return to Philadelphia on the steamer, John Stevens. Mr. Johann says that the driving wheels of the "John Stevens" were cast-iron, with spokes of H-section and that the centers were filled with ash board, $\frac{5}{8}$ in. thick.

Mr. E. A. Williams has resigned his position as superintendent of rolling stock on the Canadian Pacific Railway, and has accepted the position of assistant to the general manager of the Erie Railroad. He will have general charge of motive power and floating equipment, with headquarters in New York. Mr. Williams entered railway service in 1865 as machinist apprentice on the Milwaukee & Prairie du Chien. He became assistant general master mechanic on the Chicago, Milwaukee & St. Paul in 1890, and has since held the positions of master mechanic on the Minneapolis, St. Paul & Sault Ste. Marie Railway, in charge of the locomotive and car departments. He was made mechanical superintendent of the same road in 1893, and in 1901 he joined the Canadian Pacific. Mr. Williams is another of the motive-power officers who has been selected to fill an important position in the operating department of one of our large trunk lines.

Mr. W. S. Carter, editor of the *Brotherhood of Locomotive Firemen's Magazine*, has been elected to the office of secretary and treasurer of the order. G. W. Godding, of Chicago, has been elected editor of the magazine. Mr. Carter is a native of Texas, and was born there 44 years ago. He has had practical training on the footplate of a locomotive, having been a fireman and engineer for fifteen years. He has been nine years editor of the firemen's magazine, and during his term of office he has developed the technical and educational departments of that magazine and has

made it a very valuable medium for the 51,000 members of the organization. In his new capacity, Mr. Carter will have charge of the insurance department of the Brotherhood. During the past year it has paid to its members \$650,000 in life and disability insurance, and there is on hand about \$380,000. These figures give one an idea of the magnitude and importance of the department which Mr. Carter will hereafter manage.

Mr. Daniel Willard, general manager of the Erie Railroad, has accepted the position of second vice-president of the Chicago, Burlington & Quincy Railroad. He will have charge of all construction and operation, with headquarters in Chicago. Mr. Willard's rise to the high position which he goes to fill, is eloquent testimony as to what native ability and energy will do in this country to push a man from the lowest to the highest grade of railroad life. It is only twenty-four years ago since he began railroad work as a trackman on a Vermont railroad. Then he got a job firing, became a keen student of engineering, and used the knowledge acquired to push himself through the grades of engineer, conductor, round house foreman, traveling engineer, trainmaster, and so on, till in 1899 we find him assistant general manager of the Baltimore & Ohio. A year later he became general manager of the Erie, and now the process of natural selection gives him a still higher call. Mr. Willard's portrait appeared in our number of March, 1903.

Buy Hammond Locomotive Plant.

Fitzhugh Luther & Co., having offices in the Monadnock Block, have purchased the United States Locomotive plant at Hammond, Ind., from Gostlan & Meyn, who purchased it at a receiver's sale last week, and expect to have the works in operation within thirty days. Mr. Fitzhugh is well known in the railway world as a dealer in rolling stock.

In a letter published in a New York daily, Mr. George Westinghouse discusses the means of transmitting currents for electrically-operated railways and condemns the use of the third-rail system. He considers the overhead trolley system much safer and predicts that it will be employed in the underground lines of the Pennsylvania Railroad through New York City.

Mining College Professor: Now, I ask you as a student of practical mining, what spade do you consider the very best?

Third Year Student: Why, the ace, of course.

Energy and determination have done wonders many a time.—*Bleak House*.

Air-Brake Department.

CONDUCTED BY F. M. NELLIS.

How Air-Brake Tests Are Made.

The average air-brake man and railroad official, in contemplating the holding of a series of air-braked train trials, is, of necessity, almost wholly unacquainted with the details of such a procedure, and is very prone to regard with undue lightness many things which should receive weighty consideration. His limited experience and restricted

sary. It is the object of our article to demonstrate this fact and to illustrate in a simple, comprehensive manner how modern brake trials are held and data secured which gives us our information along this line.

The air-brake inspector or other person desiring to hold the test, must first satisfy the higher officials of the necessity for making it. Then he must find

that the "wiper," which is located on the tender frame, near the right forward journal box, and about the height of the rail above the ties, and which trips the circuit breakers at each 100-ft. section post, is in servicable condition. On each car there must be stationed two or more men to take indicator cards of the cylinder pressures, record the pressures on the auxiliary reservoir and train pipe gauges, and to watch for wheel sliding at the end of the stop.

In the specially built cabin, at the point opposite where the train pipe pressure is vented by the trip and the stop begun, there must be two men detailed to take chronograph records and calculate other data which later on is used to build up the speed and stop curves as shown in Figs. 2, 3, 4, 5, 6 and 7.

The least thought of, and one of the most important of all facilities, perhaps, is the equipment of the test, or running ground itself. This stretch of track, where the stops are to be made, must be staked off in 100-ft. sections for three-quarters of a mile or more. Circuit breakers placed at each 100-ft. section stake, and a track circuit must be connected up by electric wires. A cabin must be erected at a point near where the brake application is made, to hold the electric batteries, the delicate chronograph recording machine and electrically connected clock. A trip must be placed on the end of a tie, in front of the cabin and at the beginning of the first 100-ft.



WATCHING FOR SLID FLAT WHEELS.

A typical view just before the train comes to a standstill. The flying dust obscures the men hanging from the rear car steps noting wheel sliding.

view lead him to believe that a speed recorder on the engine to record the speed, a 50 ft. tape line to measure the length of stop, and the back of an old envelope on which to jot down the length of stops, is all the preparation out of the ordinary necessary to make a series of brake trials.

As a rule he has no knowledge of the difficulty experienced in attaining high speeds; nevertheless, he will probably boldly announce that he proposes to make all speeds from 60 miles per hour up to 120. He may be a trifle more far-seeing, perhaps, and add to his facilities for collecting valuable data such refinements as an arrangement whereby white-wash may be squirted on the ties, or red lead on the snow, simultaneous with the application of the brake to furnish a beginning point from which the stop shall be measured. Some tests were made some time ago by throwing some article like a shaker bar, or an old brake shoe from the cab to the ground simultaneous with the application of the brake, to furnish the starting point from which to measure the length of the stop; but with the modern and thorough conductor of air-brake tests, a much more careful preparation must be made, and the employment of more refined and extensive apparatus will be found neces-

sary. It is the object of our article to demonstrate this fact and to illustrate in a simple, comprehensive manner how modern brake trials are held and data secured which gives us our information along this line.

He must also take an engine and a train of cars out of service and fit them with certain special devices to obtain complete and reliable data, which, when finally assembled and developed, will give the full knowledge sought.

It will be found before going very far that the air-brake equipment of the engine and tender, or their foundation brake gear will probably have to be strengthened or otherwise modified, as those parts are seldom fit to enter or carry on an exacting brake test. Usually the braking power has to be raised higher on the tender and the cars, and possibly a brake placed on the engine truck wheels. An indicator for taking cards of brake cylinder pressures must be installed in each car. Gauges and their connections for auxiliary reservoir and train line pressures must be looked after.

In the cab of the engine must be stationed two or three men to record steam gauge pressure, air gauge pressures, speed recorded, weight and water and coal in tender, and wheel sliding, if any, at the end of the stop. They must also see that the trip on the engine for venting the train pipe pressure is at all times in good order, as well as observe



A BREAKER BOY DRIVEN FROM THE SHADY WOODS TO HIS DUTY BY MOSQUITOES.

He has gained ten pounds weight in two weeks, and would probably have done better if the mosquitoes hadn't bothered him so much.

section, to mechanically vent the train pipe pressure and apply the brakes in all stops, thus securing a uniform brake application not otherwise obtainable.

The track circuit, in charge of a com-

petent electrician, must be patrolled by a squad of four or five boys, whose duty it is to set up the circuit breakers after each stop is finished. Each boy is given a certain section of track and number of circuit breakers to care for. The boys are quite far apart, and in order to communicate with each other, and with the



A LUNCH-HOUR SCENE.

The second week's survivors banqueting (?) on "sinkers" and "rocks." The balmy air and piney woods keep them healthy.

electrician at the cabin where the circuit is tested after each stop, they must do so by the "wig-wag" system of flags, such as is practiced in the army. This code is usually designed by the chief electrician, and he teaches it to the boys. All information, whether regarding injury to circuit breakers, wires, etc., is transmitted by the boys waving a flag. To a passer-by the circling and dipping of the flags look like a holiday pastime, but in reality it is the operation of an important function of a modern brake trial, even though participated in by boys.

Instead of finishing the test in a day or so, as was originally contemplated, it will be found that fully a week has been consumed in preparation alone. It has



TWO PISTON TRAVEL EXPERTS.

taken that time to put such parts as the speed recorder, the train pipe vent trip and the circuit breaker "wiper" on the engine, taking out seats and making pipe connections to the cylinder pressure indicators and gauges which have been installed in the cars, erecting the cabin in which are housed the battery, the deli-

cate electrically connected clock, chronograph recording machine, and the electric wiring of the track circuit and circuit breakers.

Instead of the air-brake inspector and a boy, with the assistance of the train crew being able to carry on the test and collect all the data, as was anticipated when the subject was first discussed in its primary stages, there is found to be a crew of about 50 men, each assigned to a special, important post of duty. Instead of the back of the envelope being able to hold the data, each of the crew of 50 men is supplied with a ruled blank book for collecting the data at his individual station of more than 100 runs.

We are now ready for the first run. All is anxiety and expectancy, and every man is at his post. The train backs up the track to obtain a good run and get up to speed. The first run scheduled is at one hundred miles per hour. Five miles has been considered a sufficient distance in which to attain that speed. The heavy train comes tearing down the stretch, and the test is now on. The exhausts from the locomotive stack are now running together into one continuous roar. The engine whistle is sounded at a point designated by a white flag, whose staff is nailed to a telegraph pole, an eighth of a mile from the cabin, to notify the men attending the cylinder pressure indicator machine in the cars to cut in the clock work which revolves the drum on which the cylinder pressure cards are to be taken. Steam is shut off and the brake valve lapped to permit the train to fall into normal rolling condition; for it will not do to pull the train closer to the trip on one run than another. The men in the cars behind feel the tugging of the engine cease, and the novices brace themselves for an expected shock which they feel sure will follow the emergency application of the brakes by the trip on the track. They are disappointed, however, and surprised, for there is an entire absence of shock, and the brakes simply take hold with a firm, grinding grasp. The gauge pressure records are quickly taken and jotted down in each note-book, and all hands, with the exception of the indicator men, rush to the platform steps and lean out to note whether any wheel-sliding occurs.

As the train comes to a standstill with a slight jerk, the observers leap to the ground, to measure the length of the mark on the rail, if any, left by skidding wheels. If the tests are competitive, between two rival brake companies, as they usually are, there will be some little difference in the opinions of the opposing observers as to the length of slide to be recorded. A compromise is usually reached by the belligerents, however, before the official gatherer of records presents himself. Two men measure with a 100-ft. steel tape line, the distance

from the last 100-ft. stake to the "wiper" on the engine which reaches down and trips the circuit breakers, thus getting the length of the stop in feet. All is excitement. Each man wears an anxious and expectant look, as he moves aimlessly about amongst the throng, looking as though he had lost something, or



TIRING OF "SINKERS" AND "ROCKS"
They set up a Waldorf-Delmonico of their own, and have ginger ale and sardines.

peeping at his neighbor's book to obtain further information, and pushes into the crowd around the clerk whose duty it is to gather the data.

"How did we do?" "Was their stop a good one?" is guardedly asked or timidly whispered.

The uninterested and indifferent look assumed by the majority of the participants before the run, now disappears, and all hands are visibly interested. Even the breaker boys are excitedly interested, and push their way under their taller elders, into the midst of the uproar. Just at this time, an over-zealous and loose tongue may precipitate its owner into momentary trouble by expressing a



A NOON HOUR "STUNT."

The victor and vanquished of a lively wrestling bout in the hands of their seconds.
"Best two falls in three."

doubt of the truthfulness of some other observer's data, or making some complimentary reference to the competing brake; but there are usually calmer heads and older hands in the immediate vicinity to quell a threatened "scrap" in its incipiency. Three short, back-up blasts of the engine whistle

closes abruptly the arguments and discussions, and the men clamber aboard as the train backs up to the cabin to deliver data.

swings through its arc, and the lowermost part of the pendulum projection passes through a drop of mercury which has an electric attachment to the

When the engine passes post No. 1, at the end of the first 100-ft. section, the "wiper" on the tender breaks the circuit by knocking down the circuit breaker from its upright position, the pen makes a side movement and produces a break in the straight line on the cylinder paper. When the circuit breaker falls to its lowermost position, it makes a new contact, and the electric track circuit is again completed. This breaking and remaking the electric circuits actuates a small magnet coil to whose armature the pen is fastened. This produces a side movement of the pen and a break in the straight line on the paper fastened on the revolving drum.



GATHERING DATA AFTER THE TRAIN HAS STOPPED.
The flying dust, following the train, has settled.

The men in the cabin have removed the paper from the chronograph cylinder, measured it up, and now have complete data in their possession for plotting a speed and stop curve, such as are shown in Figs. 2, 3, 4, 5, 6 and 7. The time of the stop in seconds was secured by the opening of a circuit breaker in the track circuit by a man beside the train, stationed there for that purpose, when it came to a standstill. All hands, and especially the engineer and train crew, are surprised when they are officially informed that the speed of the train at the time the train pipe pressure was vented by the trip in front of the cabin was but 78.25 miles per hour, instead of one hundred. They must try again.

wires operating the chronograph pen. This connection completes the circuit,



BREAKING THE CIRCUIT
To get the exact time on the chronograph of the stop of the train which has just passed.

The next run is closely a repetition of the first. Then the train is cut down to three cars, and a speed of 85.75 miles per hour is reached. Here is the first effectual explosion of the reported phenomenal runs read of in newspapers, and told by men who held watches during some fast runs. One hundred and twenty-mile per hour runs on steam roads are myths when timed by the unerring and accurate chronograph instrument.

draws the pen from its normal marking position, and makes a side-move-

When the engine passes the second circuit-breaker the same performance is had in knocking down the circuit breaker, which breaks and remakes the circuit. This gives the pen its side movement. The line which indicates the seconds, and which the clock circuit makes, as will be observed by reference to Fig. 1, is an evenly broken line.

The line made by the pen of the track circuit, however, is not uniformly broken; and it will be observed that the distances between the broken points grow gradually longer as the train comes to a standstill.

By associating the spacings between the breakages in the light, seconds, line, and the heavy, track-circuit line, the time required by the train to pass through any 100-ft. section may be readily learned. The average speed of the train during its passage through each block may be calculated and plotted on suitable paper, and the curve drawn.

These officials are attentive and ap-

As the tests progress, the superintendent of motive power and general manager pay a visit to the test grounds to witness the runs and to learn why so much time is being consumed. They are much surprised at the extensiveness of the arrangements and the large corps of men required. They inquire regarding the purpose of the chronograph instrument and the clock. The inspector, or other person, informs them that the chronograph is a machine whose revolving drum gets its motion from a clock-work mechanism, and that the two fountain pens tracing on the paper, are connected respectively to the track circuit and to the clock circuit.

ment mark on the paper on the revolving drum.

The other pen is connected to the track circuit and the circuit breakers.

preciative listeners, and are beginning to realize that there is more details in making air-brake tests than they had found time to give due consideration.

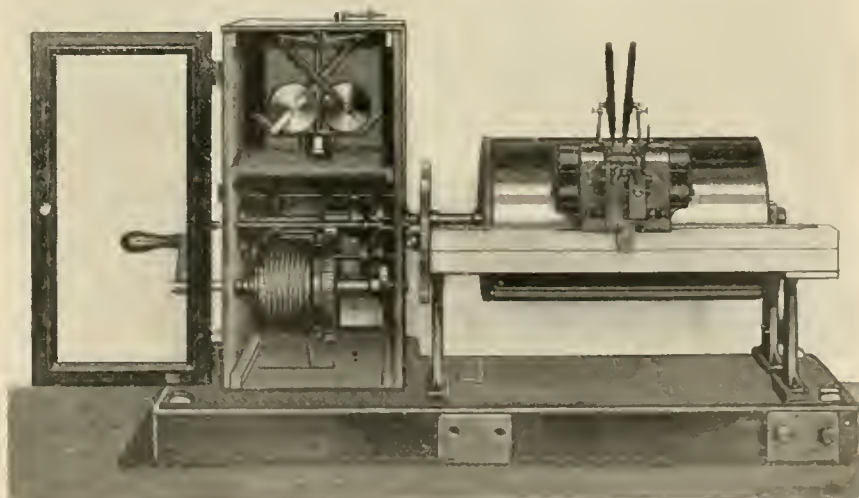

FIG. A. THE CHRONOGRAPH.

They further inquire why the several circuit breakers are placed in the track approaching the cabin, as they will be knocked down before the trip in the track is opened to apply the brakes. They cannot see why this is necessary, as it does not figure at all in recording the stop.

The insoector will promptly inform

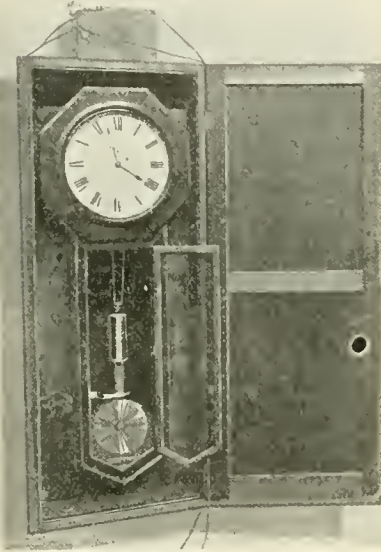

FIG. B. THE ELECTRICALLY CONNECTED CLOCK

Which ticks off the seconds on the time line.

them that while the train is passing through this negative spacing of circuit breakers, the seconds line on the chronograph sheet tells whether the train is accelerating, retarding, or moving at a uniform speed. Steam is shut off before the train comes to these circuit breakers, and the train is given an opportunity to resume its normal, rolling condition.

It is necessary to know whether the train is accelerating or retarding in approaching the point at which the application is made. With the ordinary speed recorder used on locomotives, it is possible to shut off steam at some point back of the trip, and have the speed recorder on the engine register

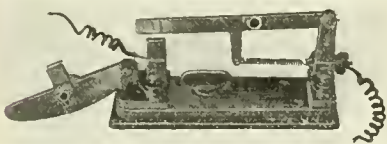

FIG. D. THE TRACK CIRCUIT BREAKER
In falling position. Circuit broken.

the same speed which it would if a train were pulled right up to the point where the trip opens the train pipe and the beginning of the stop is made.

In the former case the train would be retarding, and in the latter case it would be accelerating. The former stop may be as much as 100 ft. shorter

than the latter, and yet the engine recorder would register the same speed in both stops. This inaccuracy in the engine speed recorder is due to its structural character, and increases with higher speeds.

The officials are surprised to learn this, and they are further advised that the speed recorder on the engine is, therefore, of little real practical value in a brake test, except to guide the engineer in approximating the speed in approaching the trip. The lost motion in the ordinary speed recorder renders it utterly unreliable at high speeds, and especially in brake tests, as it will frequently fail to register as high a variation between acceleration and retardation as 3 to 8 miles per hour, even though it has been carefully calibrated immediately before being placed in the test.

The chronograph is free from this and other shortcomings peculiar to the engine recorder. In one of the tests steam was shut off and the train was drifting through the "rolling section" toward the trip. From some unknown cause the brakes crept on gradually until the brake cylinders held ten pounds pressure when the trip applied the brakes in emergency. The speed recorder on the engine made no record of reduced speed, but the chronograph did. The brake cylinder pressure cards also showed it. The stop was an unusually short one, but was thrown out. In an ordinary test it would have been counted.

And so the test goes on. The feelings of the men toward each other, even though they are rivals, grow more friendly, and finally, even cordial. For days the men in the cabin watch the tearing and roaring approach of the train, and listen to the explosive report of the train-pipe exhaust at the trip as the train rushes by and comes to a stop in an incredibly short distance. Visitors come to the grounds from other railroads to witness the tests and observe some of the shortest stops ever made with a railroad train. They are astounded to see a seven-car passenger train stopped from a speed of 50 miles per hour in the length of itself.

Weariness of the tests is first shown after a couple of weeks by the breaker boys, who, tiring of the new work, begin to inquire, "When will these tests be finished?" They are getting homesick and tired of the surroundings. The glamor has worn off the job, and they long for the old associations at home. The noon-hour wrestling and boxing matches and other "stunts" indulged in, have paled and grown uninteresting. The electrician in charge of the track circuit now has difficulty in getting a "wig-wag" signal from each boy. They

seem to shun the hot track and to prefer the cool shade of the woods along the right of way. Gathering wild flowers and catching turtles is more to their liking than keeping a constant watch for signals. But, fortunately, there is an end to all things.

Possibly, some of the older men, tiring of the work, or yielding to the distressing results of daily lunches of sog-



FIG. E. TRACK CIRCUIT BREAKER
In lower position. Circuit closed.

gy sandwiches and hard-boiled eggs, are equally anxious to get home. Indigestion and cramp colic are quite common complaints now, and each man now carries his own specific for his individual ailment. The sandwiches and hard-boiled eggs are technically known as "sinkers and rocks." At the beginning of the tests, there were no surplus sandwiches and eggs in the lunch basket. Now, there are "sinkers" and "rocks" to spare. Happily, there is an end to this, also.

Finally, the end of the tests approaches and is welcomed by all, from the breaker boys up. The train crew is most vehement in its expression of dislike of air-brake tests. It can now get back to civilization and its families, and resume its more congenial routine. The engine and cars are stripped of their special apparatus, the track circuit taken up, and the cabin dismantled of its mechanism. If the tests are competitive between rival brake companies, there will be victors and vanquished



FIG. C. THE CIRCUIT BREAKER IN THE TRACK CIRCUIT.

In the upper closed position ready to be knocked down by the "wiper."

in the departing. The data collected will soon be tabulated and otherwise prepared for general distribution, and the railway and mechanical public will possess another valuable addition to air-brake history.

The investigator will learn the very interesting fact that just thirty years

ago, the newspapers were heralding the extraordinary achievement of the air brake in bringing to a stop a passenger train weighing three hundred thousand pounds, from a speed of fifty miles per hour in 1,950 feet. He will also learn that in tests of the past year, a passenger train of 700,000 lbs. weight was stopped from a speed of fifty miles per hour in a little over 600 ft.; that is, more than double the amount of destructive energy was arrested in less than one-third the distance. This is certainly convincing evidence of the substantial progress in the air-brake art, but no more so than a symbolic tribute to the genius of the inventor and developer of the air brake, Mr. George Westinghouse.

As has been touched on in a preceding portion of this article, the chronograph record is made by placing a paper sheet upon the revolving cylinder of the chronograph and tracing lines thereon. This cylinder receives its rotative motion from integral clock-work mechanism which gives absolutely uniformity of motion. The marks on the paper are made by two fountain pens, as illustrated in Fig. A.

These pens are attached to the armatures of small magnetic coils. The pen, tracing the seconds, or time line, is in a broken circuit, and it bears normally on the drum, making its straight line, when the circuit is broken, but makes a side movement when the circuit is completed, then the magnet coil is energized and attracts the armature, drawing it to it, and in this way makes the side motion which produces the broken line.

The circuit is completed by the passing of the lowermost part of the clock pendulum through the mercury drop in the clock. (Fig. B.) As the pendulum swings once through its arc each second, the line is therefore broken once in each second also. It will be observed that the seconds, or time line, is uniformly broken on the chronograph record shown in Fig. 1.

The other fountain pen traces the line which records the indications from the track circuit. This pen, like the other, is attached to the armature of another small magnetic coil. However, this pen is in a closed circuit, and the breaks in the straight line are made by breaking the track circuit. As previously lightly touched upon, the track circuit consists of electric wires laid along the ties, and contains a circuit breaker at the end of each 100-ft. section.

This circuit breaker is illustrated in its different positions in Figs. C, D and E. Fig. C shows the circuit breaker in an upright position, with the circuit completed. Fig. D shows the circuit breaker disengaged from its upper closed position, and falling in an open position. Fig. E shows the circuit breaker in its lower

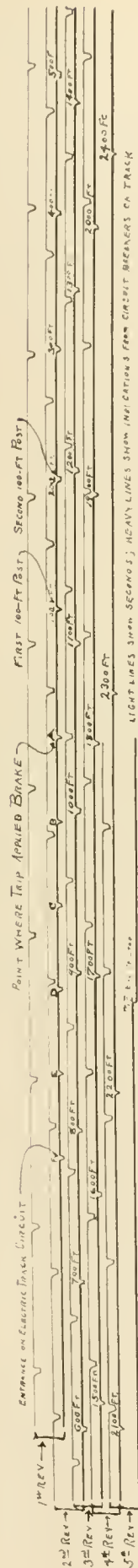

FIG. 1. A TYPICAL CHRONOGRAPH RECORD SHEET.

As will be observed, the lines go in pairs, one light, or time line, and one heavy, or speed line. The paired lines are coupled with brackets, each bracket containing the result of one revolution of the chronograph cylinder. This card required five revolutions to make a complete record. F to A is the "coasting section" of the card. It represents the distance over that portion of the track which the train is allowed to roll with steam shut off, before striking the trip at A. A is the commencement of the "stop section," where the trip applies the brake. Z is the end of the stop. The train passed through the "coasting section" of F to A at uniform speed, struck the trip at A, and came to a standstill somewhere in the 240-ft. section, in 39.44 seconds. By measuring the spaces between the breaks in the heavy lines, it will be found that the spaces in the heavy line gradually grow longer, showing a decrease in speed through each succeeding 100-ft. section.

position, where the circuit is again closed. The circuit is therefore broken when the circuit breaker is released from its upper position and drawn by its spring through the open position to the lower and reclosed position. This breaking of the track circuit causes the fountain pen, tracing the heavy line, to make a sidewise movement and produce a break in that line.

The speed and stop curve in Fig. 2 shows the record of a test run made to determine the advantage of a brake on the engine truck wheels. It also shows the stop was made from a speed of 78 miles per hour, and that a distance of 2,450 ft. was required in which to stop the train.

It will be observed that the stop made with the engine-truck brake cut out was 200 ft. more, or about three coach lengths longer than the run made with the engine truck brake cut in.

On this card appears a "collision energy" line, and will be found valuable in drawing an impressive comparison between the two stop records appearing on the same card. In other words, it is used to graphically exhibit the stored energy of the train which is still moving at a point on the track where the other train came to a standstill. This is assuming that the two runs have been made under precisely similar conditions, excepting that in one case the locomotive was equipped with an engine-truck brake, and the other was not. When the train with the truck brake came to a standstill, the other would still be running at a considerable speed.

This speed might properly be termed "collision speed," and is determined by erecting a perpendicular line from the base, or stopping distance line, to where it intersects the curve of the other stop. Then draw a horizontal line at right angles to the left through the card, to the perpendicular line indicating the speed in miles per hour. This will show at what speed the further running train is moving at the instant the shorter stopped train comes to a standstill. It will be seen in this particular case, illustrated in Fig. 2, that the train without an engine-truck brake still held a speed of nearly 25 miles per hour in passing the stopping point of the engine-truck braked train, and should it strike another train at that instant, it would do so with a collision force of 9,891,000 foot pounds.

Referring to Fig. 3, it will be observed that here are illustrated two 60 miles per hour stops, made in nearly the same distance, one being 950 ft., and the other in 990 ft. A casual observance of the card would doubtless impress the average man with the belief that there is so little difference in the two stops, only 40 ft., that they could be allowed to pass substantially as equals. However, when a

collision energy line is drawn, it is found that at the spot and instant the one train stopped, the other was still running at a speed of nearly 15 miles per hour (collision speed), and contained a destructive energy, or collision energy, equal to 3,675,000 foot pounds. It is believed by

liding with another train, was 25,700,000 foot pounds.

Fig. 5 is a card showing speed and stop curves of stops made by an engine, tender and three coaches. The first stop was made with 70 lbs. train pipe pressure, and the train was brought from a speed of

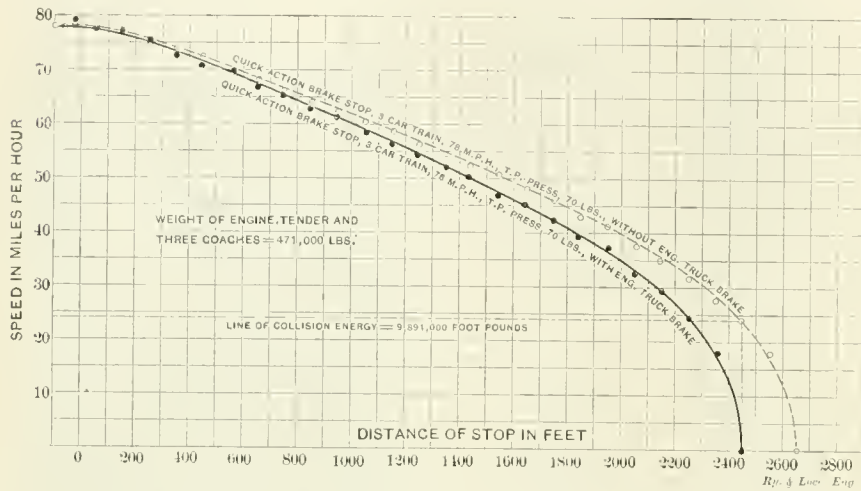

FIG. 2. RUN MADE TO DEMONSTRATE ADVANTAGE OF ENGINE TRUCK BRAKE
Collision speed, 24 miles per hour. Collision energy, 9,891,000 foot pounds.

the writer that the collision energy line, being graphically expressed and easily understood, is much the more logical basis of measurement of the relative efficiency of comparative stops.

Fig. 4 is a card containing stop and speed curves of an engine, tender and three coaches. The longer stop is made



FIG. 8. BRAKE CYLINDER PRESSURE CARD.
Emergency application, 57 1/4 lbs. in cylinder throughout stop.

with the 70 lbs. train line pressure, quick action brake from a speed of 78.26 miles per hour in 2,660 feet. The shorter stop is made with the same train, but with the high speed brake, carrying 110 lbs. train line pressure, which brings the train from a speed of 78.60 miles per hour to a stop in 2,050 ft., a shorter stop by 610 ft. The collision speed of the 70 lbs., quick action braked train, when passing

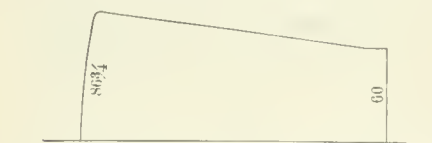

FIG. 9. BRAKE CYLINDER PRESSURE CARD.
Emergency application. high-speed brake, 86 3/4 lbs. initial pressure, reducing to 60 lbs. final pressure.

the stopping point of the 110 lbs., high speed braked train, was about 38 miles per hour, and the collision energy contained in the moving train, and capable of producing that much damage, if col-

70.87 miles per hour to a standstill in 2,060 feet. The shorter stop, as illustrated by the curve, was made with 110 lbs. train pipe pressure, high speed brake, and brought the train from a speed of 70.86 miles per hour to a standstill in 1,575 feet, a betterment of nearly 500 ft. over the other stop. The collision speed of the lower braked train, when passing the point at which the high speed braked train was stopped, was more than 36 miles per hour, and the collision energy 20,800,000 foot pounds.

Fig. 6 is a card illustrating stops made with an engine, tender and six coaches. The first, or longer stop, was made with the 70 lbs. quick action brake, and brought the train from a speed of 70.31 miles per hour to a stop in 1,885 feet. The shorter stop was made with the high speed brake, 110 lbs. train pipe pressure, and the train was brought from a speed of 70.31 miles per hour to a standstill in 1,460 ft. The fact that these two stops were made from exactly the same speed, reflects remarkable skill on the part of the engineer in bringing his train in both tests up to speed, as he was directed to obtain a speed of 70 miles per hour. The collision speed of the lower braked train was more than 35 miles per hour, and the collision energy it contained to do damage when passing the point at which the other train stopped, was 30,135,000 foot pounds.

It will be interesting to compare the two stops made in Fig. 6 and those made in Fig. 5, as all were 70 mile per hour stops, the only considerable difference being the fact that in the former case

there were three coaches in the train, while in the latter there were six coaches. This indicates that when cars are added to a train equipped with the quick action brake, the length of the stop may be reduced in a like proportion. By adding on the three coaches it was made possible to reduce the stopping distance 225 feet with the plain brake, and 110 ft. with the high speed brake.

Fig. 7 illustrates three stops made by an engine tender and six coaches at speeds of 70.86 miles per hour, 58.82 miles per hour and 50.84 miles per hour, with the high speed brake. The stops made were respectively 1,430 ft., 950 ft. and 630 ft. These are very creditable stops indeed, but it should be mentioned that all conditions were ideal under which these stops were made.

A study of the foregoing discussion should impress one with the necessity of realizing the very great importance and advantage of a brake which will reduce the length of a stop, even though it be but a few feet. Many persons, some poorly informed, some unappreciative, and others carelessly inclined, are too prone to casually inspect a speed and stop curve card, note the difference in length of the stops, and if there is but a few feet, will declare one stop substantially as good as the other. Perhaps the most logical consideration of the case would be to assume that both trains were on parallel tracks, under the same conditions and running at the same speed when the brake was applied. If one train is still running at the instant the other is stopped, the more reasonable basis of comparison is to consider the collision energy contained in the moving train and the damage it is capable of doing.

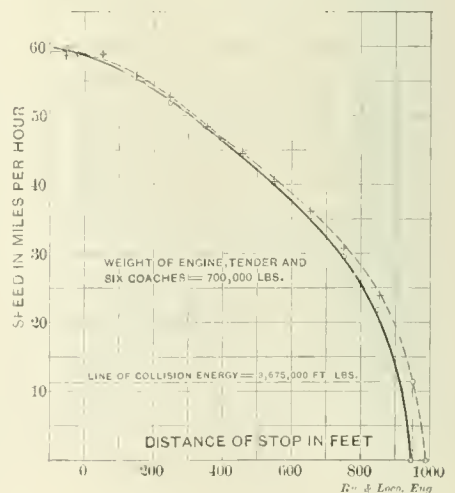

FIG. 3. SHOWING VALUE OF COLLISION ENERGY LINE
In stops apparently of equal value.

In one of the passenger train collisions of a few years ago, in which more than twenty passengers were killed, it was proved that had the train been stopped one car length shorter than it was, no

lives would have been lost. It is not the few feet difference in two stops that make them substantially equals in the eye of

and any inventor who can cut off a few feet from the last end of the stop confers the same favor on the railroad-

cylinder initially at the commencement of the stop, and that it gradually reduced down to 60 lbs. at the finish. This sloping line at the top of the card shows the gradually-reducing pressure in the brake cylinder, made possible by the high speed brake reducing valve; that is, the holding of a high pressure at the beginning of this stop, and a gradual reduction of pressure as the speed of the train slowed down to a standstill.

The average person unacquainted with the tremendous energy to be destroyed in a rapidly-moving passenger train, will be surprised to know the terrific power of the modern air brake. The power required to bring this train, running at 70 miles per hour, to a standstill in 1,400 ft., requires an expenditure of energy, which, if so applied, would lift the Empire State Express nearly one-half the distance to the top of the Washington Monument. The collision energy of this train, if dropped from that point to the ground, would be 115,500,000 foot pounds. Imagine a force that could safely lower the train from such a height to the ground,

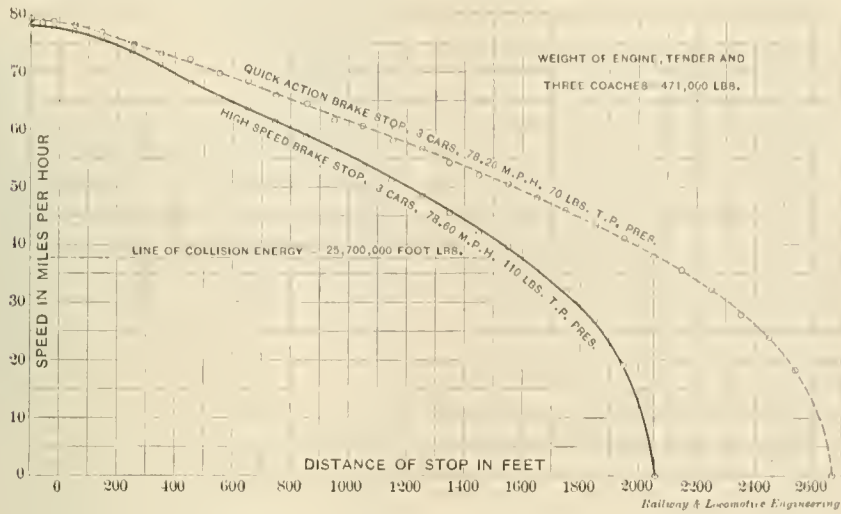

FIG. 4.—CARD SHOWING VALUE OF HIGH-SPEED BRAKE OVER ORDINARY BRAKE. Better stop made by High-Speed Brake, 610 feet. Collision speed, 36 miles per hour. Collision energy, 25,700,000 foot pounds.

the casual observer or light thinker; nor is it altogether the low speed at which the train is running which does the damage. It is the destructive or collision energy which that train contains, and which might have been controlled, but was not, that does the damage.

It is the last few feet that counts most. The Derby winner is not obliged to defeat his competitors of the race track by coming in one-third or one-half of the distance around the en-

traveling public as does the man who can make two blades of grass grow where before only one grew.

Fig. 8 is a brake cylinder pressure card, obtained during the same run that supplied data for the speed and curve card shown in Fig. 2. It was made by an indicator inside of the coach. The pressure line was gotten by running a connecting pipe from the brake cylinder to the indicator. The card was made on a revolving cylinder in a similar manner as the chronograph record.

The base line is the line upon which the card is drawn. The left hand, upward leading line, sloping slightly and gradually to the right, until it reaches a round point and then continues to the right, where it suddenly drops down to the base line again, is the record of the pressure from the time it enters the brake cylinder until the train is stopped. This is the brake cylinder pressure card of an ordinary emergency stop with the 70-lb. quick-action brake, and shows that 57¼ lbs. was obtained in the brake cylinder, and was retained throughout the stop.

Fig. 9 is a card taken of the brake-cylinder pressure of the same coach when the high-speed brake was in operation. This card has a similar base line to that of card No. 8. It will be observed, however, that the pressure line starting upward from the base line, slopes slightly to the right, similar to the preceding card, but it rises much higher. Then it gradually falls away until it reaches its lowermost point, nearing the right end of the card, and continues to the right, parallel with the base line.

This card shows that a pressure of 86¾ lbs. was obtained in the brake

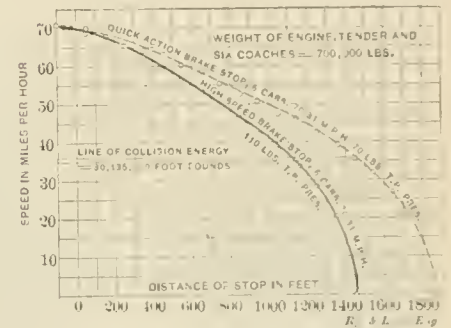

FIG. 6. COMPARATIVE 70 MILES PER HOUR STOPS WITH ORDINARY AND HIGH-SPEED BRAKES.

Betterment of stop of the latter, 420 feet. Collision energy of ordinary braked train, 30,135,000 foot pounds. Compare these stops with 3-car train in Fig. 5.

and that force will be the air-brake force required to stop the train, as illustrated in Fig. 7.

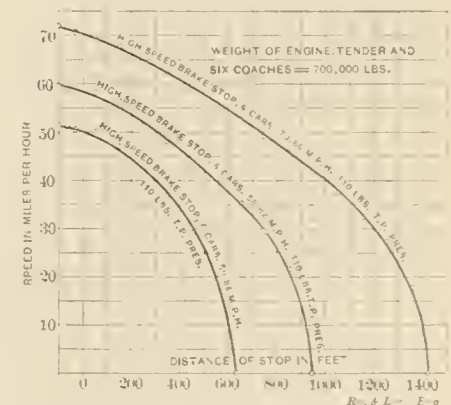

FIG. 7. SOME REMARKABLY GOOD STOPS AT 70, 60, AND 50 MILES PER HOUR, SHOWING POSSIBILITY OF HIGH-SPEED BRAKES.

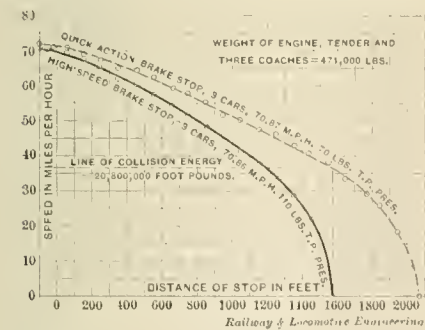

FIG. 5. COMPARATIVE 70 MILES PER HOUR STOPS.

Note longer stop and collision energy of the ordinary braked train.

tire course ahead of his competitors, to prove his deserving superiority. A half a neck, a foot or two, will suffice, and will raise his value many hundreds of dollars above that of his closest competitor who comes less than three feet behind the winner.

The athlete who runs a successful race is not expected to win the hundred-yard dash in half the time required by his closest competitor to cover the course, to establish a deserving superiority. So it is with the air brake. It is the last few feet that count most,

Moving a Big Bridge.

The Delaware, Lackawanna & Western Railroad Company have been for nearly a year working out great improvements in raising their tracks through Newark, New Jersey. On December 20 the work culminated in the moving of a huge double-decked drawbridge weighing one thousand tons was floated up stream thirty-five feet and placed on a new foundation. Four barges were secured under the bridge at low tide. Across each pair of barges were set two great boxes, 11 feet high, 5 feet wide and 54 feet long, filled with sand to within a few feet of the top, and on them rested smaller boxes acting as plungers and coming to within a few inches of the bottom of the bridge.

When the tide began to rise the immense drawbridge was lifted from its pivot of granite in the middle of the river and the floats were then drawn up stream with their burden until the bridge was poised above the new granite pier and between the newly laid elevated tracks.

Then the sand in the boxes was permitted to run out from a score of holes and the plungers carrying the weight of the bridge sank steadily and evenly into place.

We expect to publish illustrations in next issue showing the work of moving the great bridge.

The Cling-Surface Manufacturing Company, of Buffalo, have issued a small book on "New Knowledge on Belt Management," which they will be happy to send to any one who is interested enough to ask for one. Cling-Surface is not sticky, it is a filler, and penetrates into the belts. It is also a preservative for fiber, whether it be leather, cotton or hemp. When running it leaves the belt surface clean, with no dragging or adhering. It has a clinging quality which enables a belt to effectively grip a pulley, when the belt is not only not tight, but is actually quite loose. With slip eliminated a consequent reduction of wear is brought about and the life of the belt is increased. The Cling-Surface people will be glad to give any information on this question to those who are interested.

Catalogue E, January, 1904, has come from the press. It has been got out by the Duff Manufacturing Company, of Pittsburgh, Pa. The pamphlet is concerned with Barrett's patent compound lever jacks, track automatic lowering, car box, oil well and pipe forcing jacks, also differential screw jacks, motor armature lifts and traversing jack bases. The catalogue is well illustrated, with parts numbered for ordering and the price of each is given. Send for catalogue if you are interested.

Mr. Walter H. Whiteside, the manager of the detail and supply department of the Westinghouse Electric & Manufacturing Company, has also been made the general manager of the Sawyer-Man Electric Company, and has added the duties of this new office to his former ones. Few men are better known than Mr. Whiteside in the electrical business. He has been connected with electrical trade interests for nearly twenty years, and during that time has extended his acquaintanceship to every part of the country and cemented friendships wherever he went. Mr. Whiteside became a special salesman for the Westinghouse Electric & Manufacturing Company in Chicago in 1898. A year later he was sent to Washington, D. C. to take charge of sales to the Government. This led, in 1900, to his being made manager of the company's office for that district, then having its headquarters in Washington. From the Washington office he was promoted to the management of the detail and supply department of the company, with headquarters at Pittsburgh. Under Mr. Whiteside's management, the business of this department has greatly increased. Additional manufacturing facilities are being provided and a continued growth is expected.

The Hyatt Roller Bearing Company, of Harrison, N. J., have just issued their Bulletin No. 20, which shows the Hyatt Flexible Roller as applied to shop trucks, core-oven cars, jib cranes, traveling cranes, industrial railways, dryers, cement cylinders, rope sheaves, hoisting machinery, conveying machinery, glass machinery, foundry ladles, foundry wagons, lumber cars, ingot cars, trolleys, transfer cars, transfer tables, etc. In fact, this roller bearing is at its best under heavy duty at slow speed. The Hyatt roller is flexible. It is made from a strip of steel wound into a coil or spring of uniform diameter. This form of construction enables the roller to present at all times a bearing along its entire length, resulting in a uniform distribution of load on the roller itself as well as on the surfaces upon which it rolls. Write to the Hyatt Roller Bearing Co., of Harrison, N. J., for a copy of Bulletin No. 20, if you wish to get an idea of the variety of applications of which this flexible bearing is capable.

The Pneumatic Engineering Company, of New York, have issued a pamphlet on systems of pumping by compressed air. The pamphlet, which contains 47 pages, is very well illustrated with good half-tones and clear line cuts. It contains descriptions of the company's compressed-air pumping sys-

tems. The subject is divided into the air-lift pump, displacement pumps using air expansively, and displacement pumps using direct pressure of air without expansion. The method is exceedingly simple, air under pressure is conveyed into the lower end of the water pipe through a suitable foot piece. After the standing water column has been thrown off, the air rises through the water, reduces its weight with the result that the water is expelled as fast as the well supplies it. The Pneumatic Engineering Company will be happy to send a copy of their interesting pamphlet to anyone who writes to them to do so. Their address is 128 Broadway, New York City.

The Joseph Dixon Crucible Company, of Jersey City, N. J., have issued a little pamphlet which is a description and price list of Dixon's graphite lubricants. There is a short introduction and preface, and then the subject of how graphite lubricates is taken up. This is a very interesting topic, for, as the Dixon people very truly say, the soft, unctuous quality possessed by graphite is a remarkable property for a solid substance to have. The flakes of graphite tend to cover over the entire frictional surface, filling up all depressions and bringing the surface much nearer to a state of perfect smoothness. The particles of graphite do not act at all in the same way as a globule of oil does when rolling between the frictional surfaces. The pamphlet gives useful information on the subject of lubrication and will be sent free to anyone who writes to the company for a copy.

Illustrated Catalogue, No. 65, has just been issued by the Watson-Stillman Company, of 204 East 43d street, New York City. It is intended to show the extent and variety of tools made by this concern. It begins with hydraulic jacks, and it is safe to say that the ordinary railroad man will be surprised in looking over the pages of this catalogue to see the number of different kinds which are made. Next come hydraulic punches, as various in form and size as the jacks. These are followed by several kinds of hydraulic tools, hydraulic benders, lever punches and shears, power punch and shears, dies, hydraulic presses, miscellaneous hydraulic machines, hydraulic pumps, accumulators, hydraulic riveters, fittings, valves, valve tools, polishing lathes, etc. If you want to see how men and things can be "jacked up" write to the company for a copy of the catalogue.

When bad men combine, the good must associate, else they will fall one by one, an unpitied sacrifice in a contemptible struggle.—Burke.



Hot Pins.

The crank and main pins become hot. Hot main pins and hot crank pins cause you to lose time, which must be made up or counted against you.

A hot journal, if it is not watched, begins to cut, or the babbitt starts to melt.

These things are an engineer's every-day troubles, yet hundreds of engineers have written us letters to tell us that by using Dixon's Flake Graphite on their engines they have not been troubled with hot pins in the course of a long run.

Says an engineer:

"I can recommend Dixon's Pure Flake Graphite very highly for use on hot pins, as we are bothered here a great deal with them, as the division of the L. V. R. I. run is up a long, heavy grade. For 57 miles it averages 16¾ feet to the mile. Time is fast, and heavy trains. The first use I put it to was a consolidated engine. The pin was hot enough to fry meat. I simply took the cup out of the strap and poured the Graphite in the strap hole, put the cup back and filled the cup with engine oil and Graphite, and for 30 miles up hill with stock train pounded engine as hard as she would stand, and at the top of the hill found the pin cool."

Let us send you a sample to try on your engine.

Joseph Dixon Crucible Co.

JERSEY CITY, N. J.

Improvements in the D., L. & W. Ferry Terminal at New York.

Plans which have just been completed by the Lackawanna Railroad for a new ferry terminal at West Twenty-third street, in New York, call for a structure 225 feet long, extending south from the Erie ferry to Twenty-second street. The building is to be entirely of steel, and will be one of the most modern and complete ferry houses in the city. A unique feature of its construction will be the exterior, which is to be entirely of copper. There will be a central door surmounted by a dome 135 feet high. Three ferry slips will be provided, affording frequent service not only to the Lackawanna Railroad's Hoboken terminal, but also to Fourteenth street, Hoboken. There will be waiting rooms on the first and second floors, and as soon as the road secures its new fleet of double-

feet in length. The work is to be pushed with all possible speed and it is hoped that the new ferry will be in operation in less than a year's time.

Invention to Prevent Wrecks.

Two gentlemen who live in Germany have recently patented a novel device in several countries including the United States. This device is intended to prevent railroad wrecks in case an axle breaks or in case of derailment. The idea is briefly to have a short length of rail properly secured to the body of the cars just back of each truck. The rail runs across the car and is therefore always at right angles to the rails in the track. The cross rails extend out on both sides a given distance, but they have each two projections which hang down near the gauge side of the track rails.



NEW FERRY HOUSE—NEW YORK TERMINAL OF THE LACKAWANNA.

decked ferry boats, passengers will be able to go aboard the boats direct from the upper floors.

The building will have four arched entrances with a covered archway fifty feet wide. This will enable vehicles containing passengers to secure ample protection in inclement weather. It is planned also to have surface cars traverse tracks carried beneath these arches so that passengers may be carried direct to the entrance of the building. The road also has in mind the establishment of an up-to-date cab and carriage service for the benefit of its patrons and a superintendent of cab service will be in constant attendance.

It is probable that before these plans are completed additional buildings for the accommodation of railroad traffic will be determined upon, which will make the structure approximately 650

In the event of derailment the car comes down on the cross rails and slides along on top of the track with the two projections guiding the vehicle so that it does not slide off sideways or fall over. The cross rails are held in place by a screw support which permits of adjustment as tires wear or car springs become weak, so that the cross rail may always be kept at the required position, which is about a couple of inches off the track rails. The inventors regard the braking action which is brought into play when the car slides, as one of the advantages of the invention.

The nation in which labor is best treated will always be the most prosperous. The earnings of every employer of labor ought to be sufficiently high to pay employees liberally.

Norton Grinding Machine.

The annexed engraving shows the 18x96 plain grinding machine manufactured by the Norton Grinding Company, Worcester, Mass. This machine is particularly useful for railroad shops and is used for grinding piston rods, valve stems, crank pins, axle journals, etc. The gap in the table allows the regrinding or repairing of piston rods in use without entailing the necessity of removing the head.

As the increased efficiency over the old method of ground cylindrical surfaces is becoming manifest to many railroad officials, this tool deserves special attention. The machines do the work very rapidly, but there is sufficient rigidity to prevent spring, and the driving power is ample.

As an example: Piston rods sent for repair are taken directly to the grinding machine without any lathe work, and the time of grinding, including handling, is on the average, 15 minutes each.

The machines have entirely new features, among which may be mentioned

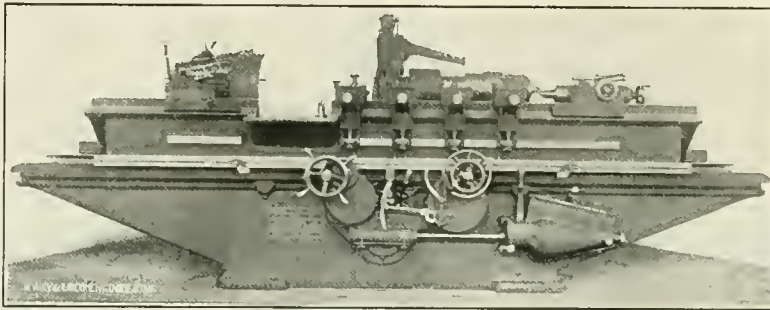

NORTON GRINDING MACHINE.

the extra heavy swivel tables of triangular section, forming a permanent water guard, and a two-way front and back support for the head and foot stocks, one of these ways being at the base of the table to give stability. The table is very rigid along its upper edge and front way to give support to steady rests when grinding heavy cuts from long or heavy work. The center of gravity of the head and foot stocks is very low and they rest on a wide base.

All changes of speed are conveniently effected at the machine, there being no overhead cones. This feature will be appreciated by all, and especially by those who have high ceilings.

There are sixteen changes of table speed, six changes of wheel speed, and eight changes of work speed. All changes can be made without stopping either the table, work or wheel. These machines are arranged for electric drive when so ordered.

Some books are to be tasted, others to be swallowed, and some few to be chewed and digested.—Bacon.

The Lubricating Problem.

M. M. Rogers & Company, of Chicago, have issued a small folder which is called "the solution of the lubricating problem." The way in which they seek to drive the hot box into the limbo of forgotten sorrows is by the use of a mixture of cotton waste and steel shavings. These steel shavings are nearly as fine as curled hair, and their presence in the waste gives to the whole a springiness which the waste itself does not possess. The mixture of waste and steel shavings is held in a stamped steel shape or one made of malleable iron, put together in sections so that it can readily be put in or taken out of a journal box.

The presence of the fine steel shavings in the waste serves a double purpose. It gives the necessary resilience to the packing, so that it is always held up against the journal, and prevents the cotton from caking and sinking and becoming soggy and rotten after continued use. The steel shavings also being a good conductor of heat carry away from the journal any heat which may be generated, and when in connection with cotton waste, which

in itself is a heat conductor, the action of the packing is decidedly cooling. In this it differs from wool waste, which, being a bad conductor, does not readily take heat away from the rubbing surfaces as this mixture does.

This subject of lubrication is a very important one, and one well worth looking into. M. M. Rogers & Company will be happy to send the folders or give any information concerning this packing to any one who will write to them on the subject. Their address is 1404-5 Auditorium Building, Chicago.

Mummies as Locomotive Fuel.

There was once in Boston a locomotive-building concern, called McKay & Aldus, which built several engines for Egypt. Benjamin Healy, who was afterward superintendent of the Rhode Island Locomotive Works, went to Egypt with the locomotives and put them in running order. When the first engine was ready for a trial trip there was no fuel ready to raise steam with. In a warehouse near the railway station there was a collection of mummies

GOLD CAR HEATING AND LIGHTING COMPANY

Catalogues and Circulars Cheerfully Furnished

MAIN OFFICE
FRANKFORT AND CLIFF STREETS
NEW YORK

BRANCH OFFICE
THE ROOKERY
CHICAGO

Manufacturers of ELECTRIC STEAM AND HOT WATER HEATING APPARATUS FOR RAILWAY CARS

THERE'S A NEW EDITION OF Air Brake Catechism

By **Robt. H. Blackall**, just issued, which is right up to date and a complete study of the Air Brake Equipment, including the latest devices and inventions used. All parts of the Air Brake, their troubles and peculiarities, and a practical way to find and remedy them, are explained. **It contains over 1500 questions with their answers.** Fully illustrated, including **Two Large Westinghouse Air Brake Educational Charts** printed in ten different colors. 300 Pages, Cloth bound. 18th edition, revised and enlarged.

Price, \$2.00

Locomotive Breakdowns and their Remedies

By **Geo. L. Fowler**. An Up-To-Date Catechism on Railroad Breakdowns, or What To Do in Case of Accidents. This work treats in full all kinds of accidents that are likely to happen to locomotive engines while on the road. The various parts of the locomotive are discussed and every accident that can possibly happen, with the remedy to be applied, is given. 250 Pages, 800 Questions and Answers. Fully illustrated.

Price, \$1.50

Locomotive Catechism

By **Robert Grimshaw**. 23d Edition just published. Asks 1600 Questions and gives 1600 Simple, Plain, Practical Answers about the Locomotive. No mathematics, no theories—just facts. The standard book on the locomotive. 450 Pages. Over 200 illustrations and 12 large folding plates.

Price, \$2.00

Combustion of Coal and the Prevention of Smoke

By **Wm. M. Barr**. A Catechism on the Prevention of Smoke. Containing over 800 questions with their answers on How to Make Steam.

Price, \$1.50

Don't put off until Exsmination Day comes, but send for these books at once, as they ask and answer many questions as given by the examiner on your road.

A Special Circular of these Books Sent on Request, or any of these Books Prepaid to any Address in the World on Receipt of Price.

AGENTS WANTED Good Pay. Write for particulars. Our catalogue of practical books sent free to any address in the world on receipt of request.

Norman W. Henley & Co., Publishers,
132 Nassau St. New York, N. Y.

stored for shipment to European museums and some one suggested that mummies would burn. The idea was considered good, and enough of Egypt's ancient aristocrats were put upon the tender to raise steam with. They proved to be good steam-making material, and others were used to make steam during several trips. Those who witnessed the experiment declared that Egypt could never be out of fuel so long as the mummy supply held out.

Sellers' 100-Inch Wheel Lathe.

The driving-wheel turning lathe here shown, made by William Sellers & Co., Philadelphia, is a tool which has great capacity for doing work expeditiously. It has two powerfully geared heads and two extra heavy compound rests, operated by electric motor attached to the machine. Both heads have very

ing only about 14,500 lbs. per square inch. A steel tube of 1¼ ins. diameter coiled into a circle of 6 ins. diameter and 0.704 in. thick stood 4,788 lbs. per square inch before bursting. Through defective material the tubes sometimes failed at 200 lbs. per square inch

About 3,500 people, it is estimated, attended the ball given recently in Buffalo by the local lodges of the Brotherhood of Locomotive Firemen. The music was good, the dancers enjoyed themselves, and those who did not dance passed an enjoyable evening in social intercourse and assisted in doing justice to the supper. The ball was a great success, and the way it was carried out reflects credit on the committee who had the matter in hand. Referring to the ball and to the next convention, the *Buffalo News* says:

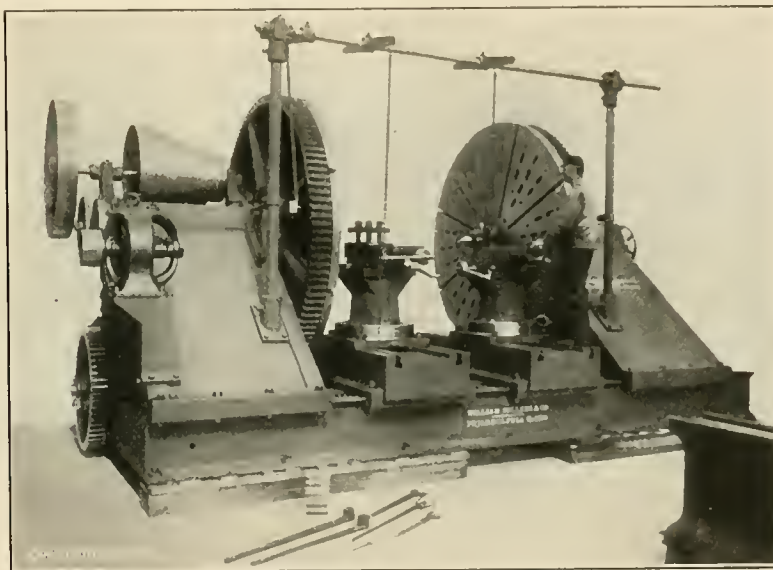

SELLERS' WHEEL LATHE.

large steel sliding spindles, with steel extension bearings and clamps. All gears are cut from solids. When operated by counter shaft, fast and loose pulleys are 36 ins. diameter by 7½ ins. face, to make 120 revolutions per minute. A quartering attachment is supplied when required.

An experiment recently tried by an English naval engineer to test the strength of the small tubes for water tube boilers showed that the tubes resisted pressures far beyond anything they could be subjected to in actual service. A copper tube of 1 in. outside diameter was plugged at both ends and a gauge attached. It was set over a blacksmith's forge and steam raised up to 2,000 lbs. per square inch, when the tube burst; this tube was 0.07 in. thick, the tensile strength of the metal be-

“It is manifest that a successful convention cannot be held without an entertainment fund. The money got last night will start the ball rolling. The firemen are great entertainers. Every city where they have met since the organization of the National body has fairly outdone itself in entertaining the delegates and their friends. It looks as though Buffalo wouldn't be behind the procession.”

We were pleased to read the following item in the *Corning, N. Y., Democrat*: “The Brotherhood of Locomotive Engineers is at peace with employers everywhere. No trouble exists at any point within their jurisdiction, which include the United States, Canada and Mexico. They have renewed their annual wage contracts with all the large railroad corporations on the American continent.”

Large Size Car Ripping-Saw Table.

The machine we illustrate here is made by the J. A. Fay & Egan Company, of Cincinnati. It possesses great strength and durability and is designed for the heaviest class of work in car shop, ship yards, etc. The frame which supports the saw and table consists of two solid ends bolted to a heavy ribbed plate connection upon which the saw frame is gibbed, giving it great solidity while leaving all parts easy of access.

The top may be either iron or wood 72x40 ins., planed true and low, to allow all heavy lumber worked upon it to be handled easily. The arbor is $1\frac{3}{8}$ ins. diameter where the saw is placed, with heavy journals designed to carry saws 36 ins. diameter. It has a patent expanding device which allows saws with different sized holes to be used without bushing.

The arbor runs in self-oiling boxes, attached to arms pivoted to the frame and raised or lowered by means of a hand wheel at the end of the machine. The

the last three weeks on account of all the box cars running hot boxes. The cause was discovered only yesterday. It was found that a big colony of cinder beetles had located in the stock yards at that station the beetles, attracted by the oil in the boxes, came over to the train for lunch. The eating of the dope did not amount to much, but some of the beetles would crawl into the journal bearing and when the train started the box would 'run hot,' melting the babbitt and causing the journal to burn off. We have had three big wrecks lately on this account, and east of Big Bend the side tracks are lined with cars the company is unable to move."—*Kansas City Star*.

This account of the cinder beetle, from Kansas, proves that the species is not extinct, but it shows that the ferocity of the insect has diminished. Our first knowledge of the beetle was in the far West and North, and roads running

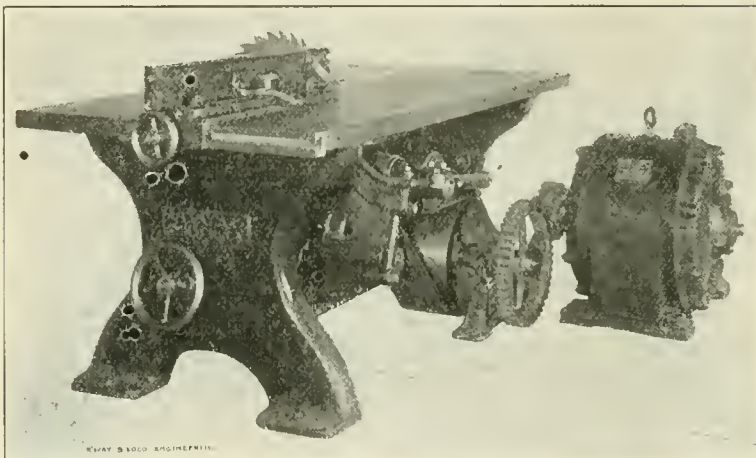

LARGE SIZE CAR RIPPING-SAW, MOTOR DRIVEN.

saw can be quickly adjusted to different thicknesses of lumber, while the table remains at the same height. A belt tightener pulley maintains a uniform tension on the belt no matter at what height the saw may be working.

The machine is provided with a patent adjustable saw gauge, the side of which is graduated. It moves in a slot in the end of the table, leaving the face of the table without bolt holes. The saw gauge can be adjusted for sawing beveled work, and can be set at a right angle without squaring. The tight and loose pulleys are 14 ins. diameter with 8-in. face, and should be run at a speed of 550 revolutions per minute. A neat electric motor, geared to the pulley shaft, drives the machine.

Ravages of the Cinder Beetle.

A correspondent explains that the freight congestion on the Central Branch is due to cinder beetles. He writes: "The situation has been bad for

through that region suffered severely. The cinder beetle of the early sixties would have scorned dope. In those days they constantly gnawed off the journals themselves and the railways had to keep their cars constantly on the move, for it was found that a well lubricated and revolving journal offered little opportunity for the insect to sink its fangs into the metal. Cars which had stood for a long time, neglected, on sidings generally became the first victims, and especially if their axle-box lids had been lost.

It is amazing the splendid inventions seen on paper that never come into practical use.

The first stand for locomotive boiler attachments that used only one hole in the boiler was invented by F. D. Childs, superintendent of the Hinkley Locomotive Works, in 1881.

"SLIGO" IRON

The Standard for Eighty Years

for

DUCTILITY and TOUGHNESS

Staybolts

Unexcelled
for Piston Rods
Crank Pins

AND DIFFICULT FORGINGS

SLIGO IRON & STEEL CO.

Successor to Phillips, Nimick & Co.

PITTSBURGH, PA.

Photographs

of Locomotives from railways all over the globe. The Largest collection on earth. Over 10,000 varieties of Locomotives, cars and trains from American, British, French, German, Italian etc., etc., railways. Samples 6x8 inches, 25 cents; 8x10 inches, 36 cents, postage paid.

ILLUSTRATED PRICE LIST FREE

THE LOCOMOTIVE MAGAZINE

Full of railway pictures and information.
6 cents a copy, postage paid.

SEND DIRECT TO

Locomotive Publishing Co., Ltd.

The World's Railway Photographer

3 Amen Corner, Paternoster Row, London, E. C.
New York Agents, The Derry-Collard Co., 256 B'way
London Agent, Railway and Locomotive Engineering



Moran Flexible
Steam-Heating

Connection, All Metal. . .

ESPECIALLY APPLICABLE BETWEEN

ENGINE AND TENDER.

MORAN FLEXIBLE STEAM JOINT CO., Inc.

No. 149 Third Street, Louisville, Ky.

The McCORD BOX

KEEPS OUT THE DUST.



SEE HOW THE LID FITS.

McCord & Company,

CHICAGO

NEW YORK.

Ball's Official R. R. Standard Watches

16 AND 18 SIZE.



17 AND 21 RUBY JEWELS. SAPPHIRE PALLETS

BALL'S IMPROVED SAFETY DOUBLE ROLLER

Are without question the finest watches that American talent and skilled labor can produce, and they are giving such universal satisfaction that we have no hesitancy in claiming that they are the best and safest railroad watch on the market.

Tests severe and numerous have proven this fact to the most critical users in all sections of the country, to which thousands of good Railroad and Brotherhood men are ready to certify.

We have an authorized agent in nearly every railroad center. Call on him for information and facts. Write us for descriptive matter.

The Webb C. Ball Watch Co.

Watch Manufacturers

Ball Building, Cleveland, Ohio, U. S. A.

ON THE PRESS

Twentieth Century Locomotives

By ANGUS SINCLAIR COMPANY

This book contains valuable facts about principles of Steam Engineering. Illustrated particulars and descriptions showing

How Locomotive Repairing is Properly Done

Has Good Articles Illustrating Piston Valves Valve Setting

How to lay out and repair Boilers How to deal with Break-downs

Is a complete hand book of ALL LOCOMOTIVE MECHANISM. No foreman, engineer or ambitious mechanic can afford to be without this book.

Illustrated descriptions of a great variety of modern locomotives.

Will be ready in January

Price \$3.00

Railway and Locomotive Engineering
174 Broadway, New York.

Patents.

GEO. P. WHITTLESEY,

McGILL BUILDING,

WASHINGTON, D. C.

Terms Reasonable. Pamphlet Sent

A New Type of Locomotive Lubricator.

The Detroit Lubricator Company, whose offices are in the Hodges Building, Detroit, Mich., have just got out a new type of locomotive lubricator which they call "The Detroit No. 20." It is much more compact than the former types, and is simpler. It takes up less room in the cab, has less parts to take care of, and it has less variety of parts, and has fewer metal joints.

Our illustration shows the way in which the sights are arranged. The danger and discomfort due to a broken glass has practically disappeared. The strain on the glass due to alterations of temperature and pressure are here met and readily disposed of. It has nothing to shake or jar off. The packing used is of a kind that will not vulcanize or blow out. There is an additional valve placed on top to control the supply of steam, thus making the device self-contained.

The device is simple, and its operation is also simple. The oil is maintained at

surface is 1,893.19 sq. ft. The heating surface made up by the tubes is 1,733.8 sq. ft.

The tank is the ordinary flat top U-shape and holds 4,000 gallons of water, the coal capacity is 7 tons. These engines are doing very good work on the B. & M., and are liked by the engineers and the officials of the road. They are good examples of fast freight power, and were built by the American Locomotive Company, at their Schenectady works, on order of Mr. H. Bartlett, superintendent of motive power of the road.

Job's Indictment.

In the thirty-first chapter of Job, and in the thirty-fifth verse occur these words: "behold, my desire is . . . that mine adversary had written a book." These words have puzzled many because it is not very apparent what particular good could have come to Job in the midst of his sufferings and while he was exhibiting his sublime patience, even if his adversary had written several books. The

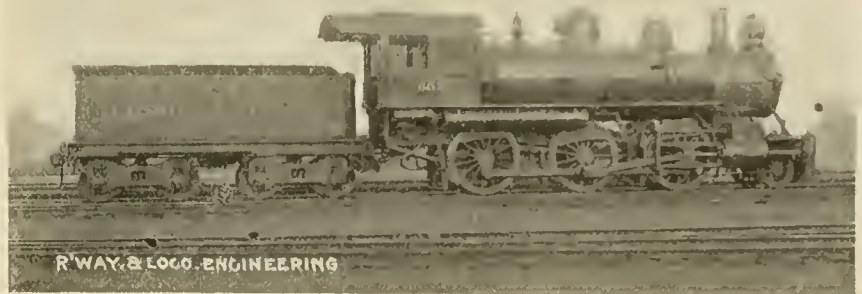

FAST FREIGHT MOGUL FOR THE BOSTON & MAINE.

a uniform temperature and will not chill. The feed is regular and all the feeds are visible from both sides. The makers claim that as compared with the former type, the cost of repairs is practically eliminated.

The Detroit lubricator people will be happy to send descriptive pamphlet to any one who sees fit to drop them a post card asking for a copy.

B. & M. Mogul.

We are indebted to Mr. F. H. Brackett, of Nashua, N. H., for the photograph of B. & M. mogul 652, from which our illustration is made. The engine has 19x26 in. cylinders, 63 in. driving wheels and has 120,875 lbs. adhesive weight. The total weight of the machine is 139,950 lbs., and the weight of the engine and tender in working order is 219,950 lbs.

The boiler is an extension wagon top and measures 60 ins. at the smoke box end. It has 286 tubes 2 in. diameter and 11 ft. 8 ins. long. The total heating

error in the translation in authorized version becomes apparent if one turns to the revised version where the latter part of same verse reads: "and that I had the indictment which mine adversary had written." There one sees at once that Job, who has been well nigh distracted by the vague and indefinite accusations of his so-called friends, who said his sufferings were due to his own evil doings, cries out that his desire is that his adversary had written a definite accusation and that he (Job) had it to deny and answer.

We mention this here to call attention to the strange use of the word "book" given above. There it meant practically a document. The word book as we use it in modern English is familiar to our readers. It not only means a printed and bound volume of some bulk, but it carries with it that further meaning which in the mind causes a book to be regarded as a source of information or as a means of entertainment. Most of our books are intended to give instruction, though there are some which combine amusement as

well. We will get you any book published, but we would be pleased to have you look over the list which follows and see if you think any of our books have been written by an adversary, which you would be called upon to answer and refute. We think they have all been written by friends who desire to help. Here they are:

The first on the list is, of course, **RAILWAY AND LOCOMOTIVE ENGINEERING**, a practical journal of railway motive power and rolling stock. It costs only \$2.00 a year, and is well worth the money, and besides the paper is a welcome visitor in every household. Let your wife and children see it.

"Locomotive Engine Running and Management," by Angus Sinclair, is an old and universal favorite. A well-known general manager remarked in a meeting of railroad men lately, "I attribute much of my success in life to the inspiration of that book. It was my pocket companion for years." We sell it for \$2.00.

"Practical Shop Talks." Colvin. This is a very helpful book, combining instruction with amusement. It is a particularly useful book to the young mechanic. It has a stimulating effect in inducing him to study his business. The price of it is 50 cents.

"Examination Questions for Promotion." Thompson. This book is used by many master mechanics and traveling engineers in the examination of firemen for promotion and of engineers likely to be hired. It contains in small compass a large amount of information about the locomotive. Convenient pocket size. We cordially recommend this book. The price is 75 cents.

"Compound Locomotives." Colvin. This book instructs a man so that he will understand the construction and operation of a compound locomotive as well as he now understands a simple engine. Tells all about running, breakdowns and repairs. Convenient pocket size, bound in leather, \$1.00.

"Catechism of the Steam Plant." Hemeway. Contains information that will enable a man to take out a license to run a stationary engine. Tells about boilers, heating surface, horse power, condensers, feed water heaters, air pumps, engines, strength of boilers, testing boiler performances, etc., etc. This is only a partial list of its contents. It is in the question and answer style. 128 pages. Pocket size. 50 cents.

"Care and Management of Locomotive Boilers." Raps. This is a book that ought to be in the hands of every person who is in any way interested in keeping boilers in safe working order. Written by a foreman boilermaker. Also contains several chapters on oil-burning locomotives. Price, 50 cents.

"Locomotive Link Motion." Halsey. Any person who gives a little study to

this book ceases to find link motion a puzzle. Explains about valves and valve motion in plain language, easily understood. Price, \$1.00.

"Machine Shop Arithmetic." Colvin and Cheney. This is a book that no person engaged in mechanical occupations can afford to do without. Enables any workman to figure out all the shop and machine problems which are so puzzling for want of a little knowledge. We sell it for 50 cents.

"Firing Locomotives." Sinclair. Treats in an easy way the principles of combustion. While treating on the chemistry of heat and combustion it is easily understood by every intelligent fireman. The price is 50 cents.

"Air-Brake Catechism." Conger. Nothing better can be found for persons trying to learn all about air brakes. Tells the whole story. New edition containing added matter relating to the New York Air Brake. Cloth, \$1.00.

"Skeevers' Object Lessons." Hill. A collection of the famous object lesson stories which appeared in this paper several years ago. They are interesting, laughable and best of all they are of practical value to-day. \$1.00.

"Stories of the Railroad." Hill. Best railroad stories ever written. Those who have not read these stories have missed a great literary treat. \$1.50.

"Standard Train Rules." This is the code of Train Rules prepared by the American Railway Association, for the operating of all trains on single or double track. Used by nearly all railroads. Study of this book would prevent many collisions. Price, 50 cents.

"Mechanical Engineers' Pocket Book." Kent. This book contains 1,100 pages 6 x 3¼ inches of closely-printed minion type, containing mechanical engineering matter. It ought to be in the bookcase of every engineer who takes an interest in engineering questions. We use it constantly as a reference for questions sent to us to be answered. Full of tables and illustrations. Morocco leather, \$5.00.

"Locomotives, Simple, Compound and Electric." Reagan. An excellent book for people interested in any kind of locomotive. It will be found particularly useful to men handling or repairing compound locomotives. It is the real locomotive up to date. \$2.50.

RAILWAY AND LOCOMOTIVE ENGINEERING. Bound volumes. \$3.00.

If you are looking for good books on railroads, engineering or on any other subject, write us a postal-card request for our Book of Books.

The Great Western Railway Company of England have decided to introduce the use of cars driven by gasoline motors for use on the lines where travel is light.

H. S. PETERS'
BROTHERHOOD TRADE MARK **OVERALLS** MADE IN U.S.A.

have gone to almost every part of the World where Overalls are worn and are everywhere conceded to be the **BEST**. Every point of material, cut, construction and finish is carefully looked after; the only way that superiority can be attained. Every garment is absolutely guaranteed. The Patented, Fleece-lined, Safety Watch Pocket is alone worth a whole suit of any other make.

I'll send sample suits, charges paid, to any place in the World where mail or express goes, where I have no retail agency; sample materials and full particulars for the asking.

UNION MADE
OF COURSE -
B.L.F. 3 - H.S. PETERS - B.L.E. 171
DOVER, NEW JERSEY, U. S. A.

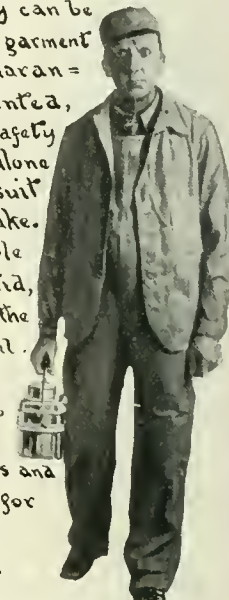

The Twentieth Century Master Mechanic

Won't use solid Mandrels. Cost too much, take up too much room and don't give satisfaction.

Nicholson Expanding Mandrels

Take everything from 1 to 7 inch holes. Take up little room—always ready and you can buy four sets for the cost of one of the solid kind.

Are You Using Them?

Catalogue tells you more about them.

W. H. Nicholson & Co.
Wilkesbarre, Pa.

**MECHANICAL TUBES
BOILER TUBES
WIRE ROPE
RIVETS
TIE PLATES**

MECHANICAL TUBES

Cold Drawn Seamless

BOILER TUBES

Cold Drawn Seamless
Lapweld Charcoal Iron

WIRE ROPE

Bright and Galvanized
Switching and Wrecking
Ropes

RIVETS

Boiler, Tank and Structural
Rivets of Mild Open
Hearth Steel

TIE PLATES

The Hart Tie Plate

CAN'T WE INTEREST YOU?

Miller, Thornburgh & Co.

135 Broadway, New York, N. Y.

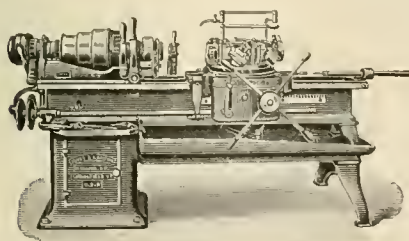

JONES & LAMSON MACHINE CO.

Main Office and Works:

SPRINGFIELD, VERMONT, U. S. A.

A. B. C and Lisber's Code used.

English Office: Room 6, Exchange Building, Stephenson's Place, Birmingham. France and Spain: Ph. Bonvillain, 6, Rue Blanche, 6, Paris, France. Germany, Belgium, Holland, Switzerland and Austria-Hungary, M. Koyemann, Charlottenstrasse 112, Dusseldorf, Germany.

Allis-Chalmers Company New Standard Reynolds-Corliss Engine.

We illustrate herewith a new Corliss engine which is being brought out by the Allis-Chalmers Company from the designs of Mr. Irving H. Reynolds. The present machine represents the experience of twenty-six years in building of Corliss engines, and combines all of the desirable elements of the best designs.

Engines of the type illustrated are being built in seven sizes, ranging from 50 to 500 h.p., and are designed for steam pressures up to 150 lbs. They are built of somewhat shorter strokes than have heretofore been customary in Corliss engines, with the idea of economizing in space and making the construction more rigid. The speeds are also somewhat higher than usual, ranging from 110 to 150 revolutions per minute, although these

clamping the hook rod firmly, is very easily detached by hand. The dash pots are of differential plunger type without leathers, or packing of any kind. The regulator is of the high speed weighted type, designed to control the engine within narrow limits of speed variation. The crank is of plain type, polished on the face, and is protected by a planished steel oil guard. The engines are fitted either with belt flywheels, as shown, or with square rim wheels where used with direct connected electric generators. The crank and crosshead pins and main journals are of a size ordinarily used with heavy duty engines.

In brief, the engine is strong, simple and compact, and while nothing has been added for ornamentation, nothing contributing to economy or durability has been omitted, and the machine should find

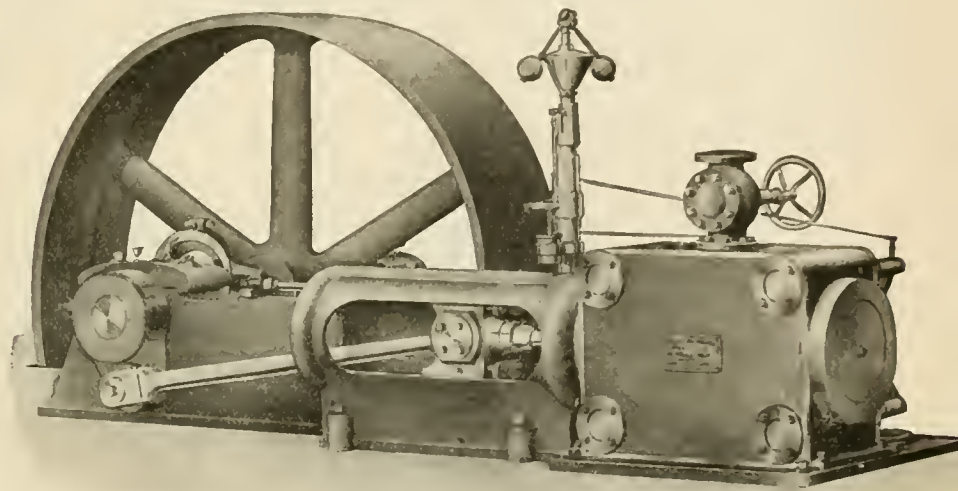

NEW STANDARD REYNOLDS-CORLISS ENGINE—ALLIS-CHALMERS CO.

speeds are not higher than those at which the Reynolds-Corliss engines of older design are frequently operated.

The frame is cast in one piece with the slide, the construction being of the box type, resting on the foundation for its entire length. The main bearing shells are bored into the frame, thus insuring a solid bearing and also permitting the easy removal of the shells by rolling them out around the shaft.

The slide is of the barrel type with bored guides. The crosshead is fitted with babbitt faced shoes with wedge adjustment. The piston rod is screwed into the crosshead and held firmly with a steel lock nut. The cylinder is of the round cornered type, is fitted with double ported steam and exhaust valves, lagged with planished steel. The cylinder is set on a cast-iron base plate, which extends under the valve gear, serving as a drip pan.

The valve gear is of the usual Reynolds-Corliss type, the wrist plate being of skeleton pattern and fitted with a new type of disconnecting device which, while

a large sale among power users who appreciate quality.

The Damascus Bronze Company, of Pittsburgh, Pa., are issuing a very handsome illustrated catalogue which sets forth the merits of the metal which they use in locomotive, car, rolling mill and engine bearings. A neat little view of Fort Duquesne in 1764 and the present day Point bridge where the Allegheny and the Monongahela rivers unite to form the Ohio is introduced on the first page in order to call attention to the fact that another of the "points" about Pittsburgh, besides the historic blockhouse is the Damascus Nickel Bronze bearing metal which has sufficient crushing resistance and ductility for satisfactory service under modern heavy freight locomotives and cars, and under high-speed passenger engines or in the bearings of machinery. The book is very tastefully printed and the half-tones are excellent. In addition to the Damascus bronze, this company also makes Damascus "Hydraulic" acid-proof metal, Damascus

- phosphorized copper, Damascus babbitt metals, suitable for railway and other uses. If you are sufficiently interested to write to the Damascus Company at Pittsburgh, you will receive their very useful and artistic catalogue.

Acme 2-Inch Bolt Cutter Driven by Variable-Speed Motor.

This 2-in. bolt cutter is one of the most popular sizes made; it threads both solid stock and tubing up to and including 2 ins. diameter. The machine requires a range of speeds from about 18 to 75 per minute. This is easily secured by the use of this variable speed motor of a horse power of 2.25, minimum speed of the motor 225, maximum 900. The connection between the motor and the machine is by a compressed rawhide gear, so that the machine is comparatively noiseless. By placing the motor on a detachable base, it may be taken off in shipping; it also does not interfere in any way with the machine;

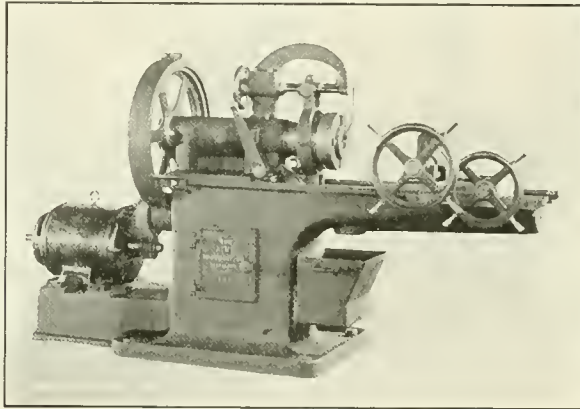

ACME 2-INCH BOLT CUTTER.

that is, it is not placed in such a way as to hinder free access to all parts of the machine.

Really there is not very much to be said on this subject because the half-tone makes it quite clear how the motor is applied. There seems to have been a good deal of humbug put out on this subject; we have had illustrations of machines that are driven by motors with a chain gearing, gearing, belting and all sorts of contrivances. We presume they are all satisfactory enough, but none of them, we think, are ingenious enough to call for any great amount of credit. We are quite sure that the above mentioned arrangement does not indicate any great mechanical genius, it is the most obvious method of applying the motor and it has been found to be effective, durable and satisfactory.

"A Good Color Scheme."

The Acme White Lead and Color Works, of Detroit, Mich., have recently issued a neat little pamphlet or catalogue setting forth the merits of their

paints, colors, enamels and varnishes for railway equipment. The pamphlet not only explains the quality and uses to which the various products of the White Lead Works may be put, but it gives samples of the colors themselves, on strips of light card which are pasted on the pages, and are thus close to the letter-press describing them. First come the Acme quick-drying car body colors, then the Acme inside baggage-car enamels in nine tints, ranging from azure to drab. There are also nine shades of Acme truck and platform enamel, followed by Aluminium enamel, truss-plank enamel, and Acme coach-roof preserver. There are six colors for railway floor paint, three samples of freight-car paint, two for caboose enamel, and five for refrigerator and special line paint.

The maintenance of way department is also well represented on the pages of this catalogue, and the engineer in charge has twenty-one samples of deli-

cate shades and tones of color to choose from, if he wishes to adopt any of the new era depot paint. Wall enamels, roof paint, bridge colors, are all given, and cannot fail to please. The book closes with samples which are used in painting signals, etc. There are red, white, yellow, green and black. The two samples of devil's red at the end of the list, one in oil and one in japan, are most striking and beautiful colors. The book is useful as a color reference, if nothing more, and can be had free by applying to the Acme White Lead Works, of Detroit.

The J. M. Carpenter Tap and Die Company, of Pawtucket, R. I., have been established and concerned in the making of taps and dies for the past thirty-three years. They are therefore the oldest manufacturers in this line. They have a well-equipped factory and are able to supply taps and dies of high quality and of all sizes upon short notice. They will be happy to forward a copy of their latest catalogue to any one who is interested enough to write to them for it.

Keep Your Mind On It

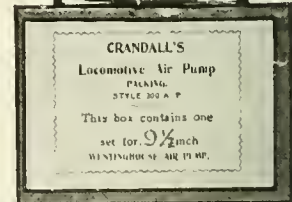

CRANDALL'S
Locomotive Air Pump
PACKING
STYLE NO. A P
This box contains one
set for 9 1/2 inch
WESTINGHOUSE AIR PUMP.

CRANDALL'S HELIOS AIR PUMP and THROTTLE VALVE PACKING

Put Up in Sets
Exact Fit to Rod and Box
Send Trial Order

The Crandall Pkg. Co.
123 Liberty Street
N. Y. CITY

Chicago Office, 30 La Salle St.



**Over One
Thousand
Miles
A DAY**
on
"The Colorado Special"

Dinner to Chicago Today
Breakfast in Omaha Tomorrow Morning
Dinner in Denver Tomorrow Evening

**SPLENDID TRAIN SERVICE
to DENVER via UNION PACIFIC**

Full Information cheerfully
furnished on application to
G. P. and Tkt. Agt.,
Omaha, Neb.

Besides **ASHTON POP VALVES**

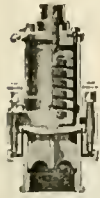

WE MAKE
 Locomotive Steam Gages
 Duplex Air Gages
 Gage Testers
 Blow-off Valves
 Chime Steam Whistles

ALL OF A SUPERIOR QUALITY
 Catalogue on Application

The Ashton Valve Company, 271 Franklin Street, Boston, Mass.

IMMEDIATE INFORMATION

IF AN ENGINEER has time to spend hours in poring over the volumes of a technical library in search of his facts, there's no doubt that he'll get them some time. In a "KENT"—that is

"KENT'S Mechanical Engineers' Pocketbook"

within the covers of one little volume of pocket size—every essential fact of the whole broad subject is noted with references for those who want especially detailed information. Records of Tests, Formulæ, Data, Rules, Standard Specifications and all Useful Tables are included—such as one needs any day.

Complete sections on Materials, Steam, Hydraulics, Fuels, Refrigeration, Electricity, etc., etc.

A digest of all that time and human energy have done in the field of Mechanical Engineering—invaluable to a practical man.

Only \$5.00 for this bed-rock foundation of an engineers' library—1100 carefully indexed pages.

THE MECHANICAL ENGINEERS' POCKETBOOK, by William Kent, A. M., M. E. Full Morocco Covers.

Through any dealer or sent postpaid upon receipt of price.

JOHN WILEY & SONS

43-45 E. 19th St. NEW YORK

The saying that "many people would do well to discard the telescope for the microscope," is particularly applicable to those engaged in engineering occupations. A general view of a machine tells little; the study of details is what counts.

At the December meeting of the New England Railroad Club, Mr. Thomas Aldecorn, of the Chicago Pneumatic Tool Company, read a paper on Pneumatic Tools and Compressed Air for General Railroad Work. The paper described many of the uses to which pneumatic tools are now put in railroad shops and the saving of time and money resulting. A discussion followed in which most of the railroad men present took part.

The Industrial Water Company, 126 Liberty street, New York, inform us that they have recently closed a contract with the Singer Manufacturing Company for the installation of one of their Water Softening and Purifying machines. The plant is to have capacity to treat 20,000 gallons of water per hour and is to be installed at the Singer Manufacturing Company's case factory at South Bend, Ind.

"We Pull For Leschens," is what you read on the large leather collars of the horses attached to the wagons of A. Leschen & Sons Rope Co., in St. Louis, New York, Chicago and Denver. These are the wagons in which they deliver their reels and coils of Hercules and Patent Flattened Strand, and all other kinds of wire rope. A. Leschen & Sons Rope Co. also manufacture and erect Aerial Wire Rope Tramways of every description; likewise underground and surface wire rope haulage plants. Their engineers in charge of the different departments have had years of experience and are thoroughly competent. 920 to 932 North First St., St. Louis, Mo., is the home address of A. Leschen & Sons Rope Co.

The Armstrong Brothers Tool Company, of Chicago, Ill., have just issued a new catalogue with price list of tool holders for turning, planing, boring, slotting, threading, cutting-off and drilling metals. The tool holders are the straight shank off-set, drop-head, planer tool, gang planer tool, side tool, drill and reamer holder, slotter tool, threading tool. The well-known Armstrong Universal Ratchet is illustrated and explained; the clamp lathe-dog and the planer jack also appear. The catalogue makes mention of the Armstrong cutting-off machine, and gives some facts concerning the metric system, and reproduces a useful table of decimal equivalents to the fractions of an inch. The "tool holder people," as the Armstrong Brothers are called, will be very pleased to send this catalogue to anyone interested enough to apply to them for a copy.

A. Leschen & Sons Rope Co.
 MANUFACTURERS

WIRE ROPE

Ballast Unloaders, Switch Ropes, Wrecking Ropes

MANILA ROPE

Fittings and Supplies

HOME OFFICE:

920-922 North First St., ST. LOUIS, MO.

Branch Offices { 137 E. Lake St., Chicago, Ill.
 92 Centre St., New York City, N. Y.
 Rialto Bldg., San Francisco, Cal.
 1717-23 Arapahoe St., Denver, Col.

The Union Switch & Signal Co.

OF PITTSBURGH, PA.

GENERAL OFFICES AND WORKS AT SWISSVALE, PA.

DISTRICT OFFICES:

New York: Central Building, 143 Liberty Street.

Chicago: 1536 Monadnock Building.

St. Louis: Terminal Station.



Better Belt Service ^A

Cling-Surface is a filler and preservative for belts, making and keeping them pliable, elastic, waterproof, preserved.

It stops slipping entirely, allowing all belts to run easy under fullest loads.

It is not a sticky belt dressing. Used by Pa. R. R., D. L. & W., P. & R., D. & H., Iowa Cent., N. Pacific, A. T. & S. F., American, Rogers, H. K. Porter Locomotive Cos; American Car Co., Carnegie and Westinghouse Cos., and many others.

Order on approval. We guarantee it. Ask for book, "New Knowledge on Belt Management."

Cling-Surface Mfg. Co.
 Virginia Street Buffalo N. Y.
 Branches in leading cities

The air-brake people on the Manhattan Elevated Railroad in New York City, have adopted a plan for cooling the air as it passes from pump to main reservoir. They have arranged about twenty feet of pipe to connect pump and reservoirs, though the pump is close to the reservoir as far as position goes. The pipe runs along under the car outside the reservoir for about ten feet and turns round with an easy bend and runs back about ten feet more to the reservoir, and when stayed in position it looks like a trombone. You can call it the trombone attachment, if you like, but it cools the air just the same.

Locomotive building seems to be improving. At the Baldwin Locomotive Works the reports are good. "We are turning out several locomotives a day," said Superintendent Vauclair recently, "and we are using our entire force to do it. With the orders we have on hand we will be obliged to continue night and day at the present pace for four months in order to fulfil our contracts. It is easy to see under these circumstances that there is no basis for the reports that several thousand hands were to be laid off."

The master mechanic in charge of a division shop of a trunk railroad who visited this office lately mentioned that he had noticed the pneumatic valve setting arrangement illustrated in the August number of RAILWAY AND LOCOMOTIVE ENGINEERING and ordered one to be made. His men are now using it and he figures that it effects a saving of \$15 a week in labor alone. It also does the work more expeditiously and the valves are better set than they were by the hand-turning apparatus.

The Interstate Commerce Commission is satisfied with the report of the committee of railroad master mechanics in reference to the application of the requirement of the safety appliance law to locomotives. The difficulty was in interpreting the law, but this has been satisfactorily adjusted by concession on the part of the Commission and willingness on the part of the master mechanics' committee to meet the requirements of the law when construed in a manner admitting of practical application.

Our subscribers would be doing the mailing department of RAILWAY AND LOCOMOTIVE ENGINEERING a good turn if, when any change of address takes place, they would endeavor to send notice of the fact to us, if possible before the tenth day of the month. If they send us notification after the mailing list is in the hands of the printer, delay for themselves and extra work for us is the result.

CONTENTS.

	PAGE.
Air Brake Department.....	35
How Air Brake Tests Are Made.....	35
Book Reviews.....	18
Cheating by an Endless Chain.....	10
Dangers of Early Railroad Locating.....	6
Development of the Eight-Wheel Connected Engine on the B. & O., The, by J. Snowden Bell.....	27
Easy Way of Calculating Engine Horse Power.....	2
Editorial:	
Compound Engines.....	16
Helping to Make Hard Times.....	18
Properties of Materials.....	18
Untidiness and Waste.....	18
Value of Knowing Common Things.....	17
Electric Traveling Gantry Crane, An.....	6
General Correspondence:	
Allfree Valve Gear, The.....	11
Care and Handling of the Compound.....	11
Heavy Locomotive on the Swedish State Railways.....	12
Position of Reverse Lever on Piston Valve Engines.....	12
Progress.....	11
Growth of the Locomotive, The, by Aogus Sinclair.....	3
Harter's Patent Ball Joint.....	22
High Speed Spurts and Average Performance.....	1
Improvements in the D., L. & W. Ferry Terminal at New York.....	43
Job's Indictment.....	47
Locomotives:	
B. & M. Mogul.....	47
C., B. & Q. Prairie Engine.....	21
Curious Express Locomotive.....	14
Heavy Consolidation for the L. S. & M. S.....	31
Passenger Power for the El Paso & Southwestern.....	15
Simple 4-6-0 for the Chicago & Northwestern.....	20
Moving a Big Bridge.....	42
Paper Wheels.....	40
Pennsylvania Locomotive Testing Plant at St. Louis, The.....	22
Personals.....	33
Principal Electric Units.....	30
Questions Answered.....	19
Signals and Signaling, by George S. Hodgins.....	7
"A Signal Success".....	24
Slipping With Steam Shut Off.....	27
Standardization.....	22
Texas Law and Car Supply.....	23
Underhung Springs and Breakdowns.....	2
Vestibule Stock Car.....	24
Wants Fair Play for the Compound.....	23
Wilmarth Engines, The.....	21

Work is fast nearing completion upon the new power plant of the B. F. Sturtevant Co., at Hyde Park, Mass. This bids fair to be one of the most complete plants of its kind in the country, special care having been taken in connection with every detail to secure the highest efficiency and the most modern equipment. The plant will comprise four water tube boilers, with stokers supplied by Sturtevant forced draft, an economizer with Sturtevant induced draft, and a complete outfit of Sturtevant generating sets, together with condenser, air compressor, etc. The Sturtevant exhaust head is used for separating the water and oil from the exhaust steam.

Let us improve our minds by mutual inquiry and discussion.—*Mr. Pecksniff.*

**Handy Folding
PILOT COUPLER**



A safe and neat construction for front ends of road locomotives

Handy Car Equipment Co.
Old Colony Building
Chicago

IF YOU ARE A
BOILER MAKER
OR
SHEET IRON WORKER

and are interested in laying out work, send for my sample blue print.
It contains 20 practical problems in sheet metal work, and fully explains my practical method of teaching the subject. Sent upon receipt of 6c. in stamps.
EDWARD BRADY, Room 217, 38 Park Row, N. Y. C.

THE ROBERT W. HUNT & CO.
Bureau of Inspection, Tests and Consultation,
1137 THE ROOKERY, CHICAGO.
66 Broadway, New York. Park Building, Pittsburgh
31 Norfolk House, London, Eng.
Inspection of Steel Rails, Splice Bars, Railroad Cars, Wheels, Axles, etc. CHEMICAL LABORATORY Analysis of Ores, Iron, Steel, Oils, Water, etc. PHYSICAL LABORATORY—Test of Metals, Drop and Pulling Test of Couplers, Draw Bars, etc.
Efficiency Tests of Boilers, Engines and Locomotives.

FOR SALE
FREIGHT, PASSENGER AND LOGGING
LOCOMOTIVES
AND
CARS QUICK DELIVERIES
ALL SIZES. **F. M. HICKS,** 385 DEARBURN ST. CHICAGO, ILL.

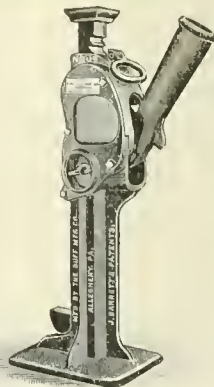

BARRETT
Car and Wrecking
JACKS

Are Quick-Acting,
Powerful and
Easy Handled.

For speed Reliability and Efficiency they are universally recognized as vastly superior to Hydraulic or Screw Jacks.
Used by all leading railroads for Car Work
in the Shop or on the road as part of the Wrecking Equipment.
Send for the "Yellow Book," made exclusively by

THE DUFF MFG. CO.
Works: Allegheny, Pa. **PITTSBURG, PA.**
FAIRBANKS, MORSE & CO., Chicago
Agents for Railroad Dept.

Railway and Locomotive Engineering

Copyright by Angus Sinclair Co.—1904

A Practical Journal of Railway Motive Power and Rolling Stock

Vol. XVII.

174 Broadway, New York, February, 1904

No. 2

The Value of a Library.

The surprising call upon us for back numbers of RAILWAY AND LOCOMOTIVE ENGINEERING and the increased demand for bound volumes of the year's issue has caused us to wonder and to seek an explanation of the peculiar phenomena.

A careful analysis of the subject is

room where they await their turn at the single copy on the library table. This method is possibly cheaper at first cost and seemingly fairly satisfactory for the moment, but decidedly is not so in the long run. And this is where the reader is not fully cognizant of his own future interests, and is not loyal to himself.

capital, and the foundation on which his knowledge is built and stands. No matter if it is small, if it be made up of good books, it is a treasure and comfort in itself. It is a teacher which may be consulted with unlimited frequency and the greatest ease.

Subjects of great importance are overlooked by the general reader in



A SEASONABLE SCENE IN THE ROCKY MOUNTAINS.

very interesting. It shows that a portion of our readers, while loyal to us, are not as loyal to themselves as they should be. They read each issue of the paper, possibly buying single copies intermittently from news dealers, borrowing at other times from neighbors or friends, or dropping into a reading

Reading and self-education is one of the strongest characteristics of the American railroad man. He is essentially a student by nature and a seeker of knowledge, especially such knowledge as pertains to his immediate surroundings, and extends to things generally. A library is largely a student's

hurriedly going through a periodical and afterwards he regrets that he did not note the whole more carefully and wishes he might have the opportunity again, and he would make more of it, but it is too late.

The strongest advice given by all educators to readers and students is to

start a library of one's own, add to it with good books, buying with careful judgment from time to time, thereby wisely selecting additional books and spreading out the cost and making it less felt. Start a library of your own.

The proportion of railroad men possessing libraries of their own is increasing rapidly. There are to-day ten railroad men owning libraries of their own where a few years ago there was but one. And these libraries consist of good useful educational books, by many authors, and not merely whole sets of gilded backs by a single author, which are seldom used and stand merely as an ornament and a flimsy pretense that the owner is "a man of letters." The titles of the books and the personality of the man tell truthfully whether the two are congenially mated.

Nor should a selection of books be restricted to mechanical works alone, for every man intellectually healthful and creditably broad in mind must be interested in other subjects than those which pertain alone to his daily business. Nevertheless a complete mastery of the details of a man's business, which bring him his bread and butter, should be held paramount. The essentials first and the trimmings afterwards.

We cannot refrain from advancing these observations and opinions, for our attention has been so forcibly drawn to the matters under discussion that we feel some prominence should be given them. We feel there is no educator like a good course of reading. There is no course of reading offered equal to that supplied by a good library of books built up on the possessor's needs and on subjects which interest him. Neither is there an easier educational or more efficacious course than pleasant and agreeable reading. Plodding and grinding literature is not suited to the man who spends more time on the road than at home. His literature must be made interesting and restful, else he will tire and stop it. Such are the lines along which RAILWAY AND LOCOMOTIVE ENGINEERING is conducted. One reads and learns while he is being entertained and interested.

Our kindest and sincerest advice to our readers is to start a library of their own at once, before it is too late and back numbers are obsolete. Start the library with RAILWAY AND LOCOMOTIVE ENGINEERING. Keep it up. Add to it from time to time as your means will permit, but make RAILWAY AND LOCOMOTIVE ENGINEERING the nest egg. And when you are enjoying the sweet fruits of the inevitable result which comes from a good, wholesome library, remember that it is the outcome of the friendly advice given you by RAILWAY AND LOCOMOTIVE ENGINEERING.

Leaky Flue Hoodoo.

BY JOS. A. BAKER.

We have all had our ideas about boiler failures of large engines, assigning various causes, but the preponderating number of these failures have been attributed to the lack of care the boiler received by the roundhouse force and engineers. If these are the true causes where the pooling system is in vogue and nobody's engine everybody's engine, the company has itself to blame. But what about the man with a regular engine? I have in mind many cases where the utmost care and attention were bestowed on the engines by their crews and the roundhouse force, and still the "critter" would die away from home. I have seen engines pull up to water tanks popping off, while the engineer oiled the machinery and the fireman filled the tender. During this time the fire-box door was not opened, but in less than ten minutes it was found necessary to give up the train on account of flues leaking badly. Some thought it was because of vibration of longer flues. If such were the case, why would not the vibration have the same effect on the smoke-arch end as in the fire box? A little thought will turn us in the right direction.

Let us take the designer to task. He it is who sent the blue prints to the builder; he it is who conceived in his fertile brain the idea of adding more heating surface by crowding more flues in the same sized sheet or possibly raised the crown sheet to add still a few more. The shallow fire box is his idea and so is the extension front. The diamond stack was discarded for the extension front with a straight stack as something better—something to gather up and hold the cinders to be used as road ballast.

Some one with an economical turn of mind even suggested that these cinders could be used again to save the unconsumed carbon in them. We have not got back to the diamond stack—pride forbids—but we are earnestly trying to find a way to make the extension front peddle out those cinders en route as the old diamond stack did.

Compare the engine of ten years ago with one of to-day. It is a well-known fact that the engine with low crown-sheet, fewer flues and deep fire box seldom raised the water more than an inch or two in the glass when crowded, and was a fine steamer. The engine of to-day with its increased flue area, shallow and wide fire box raises the water from a half to a full glass and out of sight as soon as the throttle is opened. Why? Simply because we have narrowed down the space between the flues to such a degree that there is very little room for the water to circulate. In bad water districts this space is further reduced by rapid scale formation. In these cramped

conditions, forcing the draft through the flues drives the water to the top of the boiler. With our extension front ends the lowest flues do the hardest work, consequently with the excessive strain put on them and the water driven from them, over-heating takes place. As soon as we close the throttle, the water returns to the exposed flues and sheets, contraction follows, the flue gets smaller and the flue hole larger. Result—leaky flues, dead engine.

With the shallow box the fire is near the flues and acts on them like a blast from a forge, burning off the bead of the flue. With the wide box giving more grate area, the temperature of the box is increased in proportion and this taxes the flue also. Should we take these flues that always begin to leak when the throttle is closed—and it is an indisputable fact that leakage of flues always occurs immediately after the throttle has been closed and not before—and deduct their area from the total flue area, we shall find that we have less effective flue-heating surface and a poorer steaming engine in the present type than we had with our former style of engine. In the earlier engines with fewer flues and wider spacing we got a better circulation, as each flue contributed its quota of heat, and converted it into energy, as shown at the steam gauge and safety valves under any and all conditions of service.

The diamond stack was certainly as artistic as the straight stack and it had two advantages. The diamond stack gave an equal draft on all the flues, and it did not need committees from half a dozen organizations to investigate and decide on the most effective method of getting rid of cinders and securing free steaming engines.

Working on these lines will help to obtain better results and will also do much to remove the stigma unjustly attached to the roundhouse and engine crews.

The Joy valve motion obtained great favor among locomotive superintendents in Great Britain twenty years ago and the appearances were that it would drive the discredited link motion out of service. A reaction appears to have come for we rarely see Joy's motion on new engines. They have discovered that the shortcomings of the link motion may be excused when they are compared in practice with the shortcomings of improved valve gears.

Mr. W. D. McNicholl, vice-president of the Canadian Pacific Railway, announces that the company's locomotive and car shops, now in course of completion, located between Mile End and Hochelaga Stations, at Montreal, will be known as the "Angus Shops," no doubt after Mr. R. B. Angus.

Ten-Wheel Passenger Engine for the Seaboard Air Line.

The Seaboard Air Line Railway, of which Mr. R. C. P. Sanderson is superintendent of motive power, has recently bought from the Baldwin Locomotive Works some ten-wheel engines for passenger service; a reproduction of one of them is here given. The cylinders, which are simple, are 20x28 ins., and the driving wheels have a diameter of 67 ins. All the wheels are flanged. The pistons drive on the center pair, which gives a good length of connecting rod. The valves are of the piston type, outside admission, and the motion is direct acting. A transmission bar passes from the link block over the forward driving axle to a rocker, the upper end of which is only just below the level of the valve rod, and whose center line corresponds with the center of the valve-stem rocker.

This arrangement causes the valve to have a slightly longer travel than the ec-

The windows in the cab are arranged with an eye to the comfort of the men. The even spacing of the driving wheels gives the engine a symmetrical and solid appearance, which effect is heightened by the long, unbroken line of the running board. A few of the principal dimensions are as follows:

Cylinder, 20x28 ins.; valve, balanced piston.
 Boiler—Type, wagon top; dia. 63 $\frac{1}{4}$ ins.; thickness of sheets, $\frac{3}{8}$ and $\frac{1}{2}$ ins.; working press., 200 lbs.
 Fire box—Length, 108 ins.; width, 42 ins.; depth, front, 75 $\frac{1}{4}$ ins.; depth, back, 63 $\frac{1}{4}$ ins.
 Water space—Ft., 4 ins.; sds., 3 $\frac{1}{2}$ ins.; bck., 3 $\frac{1}{2}$ ins.
 Driving wheels, dia. of outside, 67 ins.
 Wheel base—Driving, 13 ft. 6 ins.; total engine, 24 ft. 4 ins.; total engine and tender, 51 ft. 6 ins.
 Weight—On driving wheels, 132,610 lbs.; on truck, front, 32,480 lbs.; total engine, 165,090 lbs.; total engine and tender, about 265,000 lbs.
 Tender—Wheels, dia., 33 ins.; journals, 5 ft. x 9 ins. tank capacity, 5,000 gals.

When Reliable Engineers Were Scarce.

During the pioneer days of railway construction much difficulty was experienced in obtaining reliable locomotive

but, as a rule, a better comprehension of the locomotives used was then necessary than is requisite now, on account of the marked improvement in systems of repairing; and if a train was derailed it frequently became the duty of the engineman to set matters right without aid from a wrecking train.

The enginemen seemed to have some peculiarities that would be considered extraordinary at the present day. When the introduction of engine cabs was first proposed the locomotive engineers strongly objected to their use, for the reason that they believed that the dangers to which they would be exposed in case an engine was overturned or thrown off the track would be materially increased by confinement in the cab.

In the course of a discussion which arose in the *Locomotive Engineer* in 1891 about the operating of the Columbia Railroad without train rules, Mr. W. De Sanno wrote:

"Some modern railroaders will say that



TEN-WHEEL PASSENGER ENGINE FOR THE SEABOARD AIR LINE.

centrics have throw, and the eccentrics are set on the axle with their centers on the side, remote from the axle. To put it another way, if the figure IX on the dial of a watch represent the crank pin, the lines through the centers of the eccentrics would mark 5 minutes past 5, and the forward eccentric would be represented by the minute hand. The springs of this engine are underhung except over the leading driver. The piston rod is secured to the cross head with collar and nut, and the side rods are fluted.

The boiler measures 63 $\frac{1}{4}$ ins. at the smoke-box end and the gusset sheet slopes up to connect with the third course which is 70 $\frac{5}{8}$ ins. in diameter. The fire box has a grate area of 31 $\frac{1}{2}$ sq. ft. The total heating surface is 2,613.87 sq. ft. There are 332 tubes 14 ft. 1 $\frac{7}{8}$ ins. long, and these contain 2,446.35 sq. ft. of heating surface. The crown and roof sheets are level and the back sheet is perpendicular.

enginemen. On account of the exposure to which they were subjected before cabs were furnished and comparatively low wages, few machinists who understood engines cared to continue in the business. Smart young blacksmiths were found to be the best class to select from by some roads. In other districts young men trained as farmers and accustomed to miscellaneous farm labors, but not experts in any class of mechanics, proved most serviceable. The duties imposed were in several respects peculiarly responsible and onerous, inasmuch as the engineman was expected to understand the machine he was operating sufficiently well to give directions for a considerable portion of the requisite repairs, which were often made by men who had no other training than as blacksmiths. Instances of defective knowledge on the part of the inexperienced engineman were by no means uncommon, and occasionally ludicrous blunders were made.

the road could not be operated without some regulation in the running of freight trains, but remember it was a double track road. At the same time we do not claim that the trains did not come together sometimes. The writer has seen the four-wheel freight cars of the day piled up like so many packing boxes. The engines carried iron flags that were painted in imitation of an American flag with "last train" painted across the end of the staff.

"It was useless for any one to try to ride on a freight train or for individuals to try to get cars off that day if the flag had passed. When a flag was not at hand a stick of wood with rags tied around the top or an old broom stuck in the bumper beam was used. Either one was an infallible sign that no more trains would pass that day. I am now speaking of freight trains only. Passenger trains ran on time not by a flag unless blocked, but by virtue of over-

hauling one or more freight trains going in the same direction.

It was not an unusual thing for two or three freight trains to come into a station, the one pushing the other, with a passenger train bringing up the rear, each little engine doing her best, and their valves all set in a different key, good, bad and indifferent.

Continuous Draw Gear and Rough Handling.

Looking at the question of continuous draw gear from the standpoint of what ought to be, rather than from what is, one would probably expect continuous draw gear to be almost an ideal form. With this kind of draw gear each car pulls its own weight alone, and the cars are simply like tags on a chain. In the days when engines were lighter and trains shorter than they are now, this kind of draw gear reduced the shocks on cars in starting and stopping, because a car did not receive a blow from the accumulated weight of all in front of or behind it.

The accompanying illustration shows what actually happens to continuous draw gear keys now-a-days on a certain western road. The master mechanic who favored us with the photograph in assigning the reason for failures amounting to more than one thousand a month, laconically remarks, "Heavy engines, rough handling." It is easy to see that the keys are in such shape that they have necessarily ruined the draw timbers before they were taken out and the car repair account goes up in proportion.

Inherited Cleverness.

In certain countries it was the regular recognized practice for sons to follow their father. This was carried on to such an extent that certain trades were dominated by persons who were nearly all

ability that the descendants of people who have followed the same occupation generation after generation inherit a fitness for the work which others do not possess. The marvelous skill which some families of artisans have been noted for may have been due in some measure to heredity.

Heredity does not, however, always entail cleverness, although it nearly always conveys the conceit of breeding. An anecdote is told of a Scots minister who was an ordained incumbent of the Kirk of Scotland and had seven sons who were all ordained in the same call-

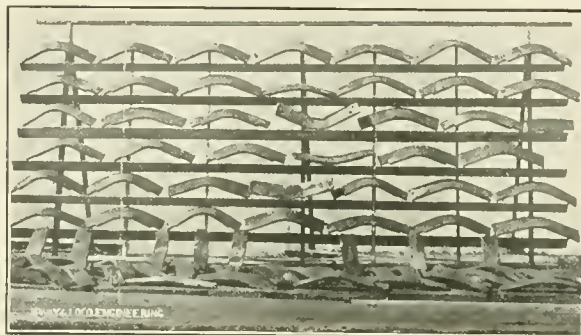

CONTINUOUS DRAW-GEAR KEYS BENT.

ing. On the day that the youngest son went through the ceremony of ordination the father was moved to boast of the glory of his family to the Kirk beadle.

"See here, John Tamson," he remarked, "in all your experience you have not seen a case to equal mine. I, Robert Robertson, am an ordained minister of the Kirk of Scotland and I have seven sons, every one of them ordained ministers of the same Kirk."

John, who was a contradictory man, as some Scotsmen are, replied: "I have never seen an equal case among ministers, but I ken o' a case unco like yours. There is Duncan McGregor, the Laird o' Udney's piper. The father is a laird's piper and he has seven sons a' lairds' pipers, an' the deil a decent tune can they play among them."

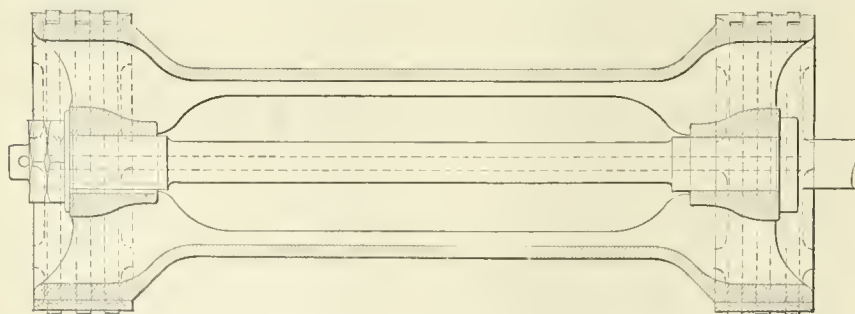

PISTON VALVE, BALDWIN ENGINE. SIX PACKING RINGS.

(See page 55.)

blood relations. The same tendency is today found to prevail to some extent on British railways, where the sons of railway men have preference over others in obtaining employment. There is a prob-

Superstitious Preventative of Boiler Leak.

After innumerable experiments and many years of experience railway men generally who are responsible for the

care and maintenance of boilers have reached the conclusion that the only practicable way to overcome the evils of water impurities is to separate the solids before it goes into the boiler. It is very amusing to think over the remedies tried on various roads for years. They remind one of the superstitious practices followed to guard against bad luck. The ordinary negro still believes that there is powerful occult saving grace in a rabbit's foot, and many people afflicted with rheumatism cherish a raw potato carried in the left trousers pocket.

Among the numerous superstitions of actions and articles recommended to prevent boiler scale, and largely used at one time, were: As much kerosene as the boiler would stand without foaming; raw potatoes, each dose to be one-fiftieth the weight of the water; a mixture consisting of twelve parts common salt, two and one-half caustic soda, one-eighth extract of oak bark, one-half part of potash. Pieces of oak bark suspended in the boiler and changed once a month. Two ounces muriate of ammonia applied twice a week. To coat a

boiler to prevent the adherence of scale a mixture having three parts of graphite, eighteen parts of tallow and two parts of sulphur, which must be applied weekly. Thirteen pounds of molasses fed weekly has a softening effect on scale. Mahogany or oak sawdust fed regularly prevents hard scale from forming. Tannic acid in small quantities converts the scale forming elements into mud. Slippery elm bark has been considered in some quarters a certain remedy. Carbonate of soda, chloride of tin or spent tanners' bark have been considered worth trying.

Most of them are very much like the hope which moves the rheumatic person to cherish a potato in his pocket or an iron ring on his finger. The belief was that they would do no harm if they effected no remedy. Some of them, like muriate of ammonia and tannic acid, were liable to corrode the boiler.

In setting the flues of locomotives the most common practice is to put copper ferrules on the fire box end and the plain tube on the same box end. The copper ferrule is put on at the fire box end because it tends to prevent breakage, and it is useful for that purpose; but it would be better to put ferrules on the front end also because it enables a flue to be easily removed. Some railroad companies do this and it pays them well. When flues get covered with scale and have to be removed through the small hole bored to fit the tube it is a difficult operation and flue sheets are frequently cracked in trying to twist out the flue.

Power of Habit.

We are acquainted with a gentleman who carries an umbrella until it is worn out. His explanation for doing so is, that he never ventures out without it, rain or shine. Sheer force of habit prevents him from leaving it where he stops, a common fate of most umbrellas. If the apprentice who is learning a trade or a fireman engaged to keep up steam on a locomotive would adopt a similar plan at the beginning of his career of doing his work in first-class shape he will form a habit that will stick to him like the gentleman's umbrella and which in later years will bring him large returns. Few people realize the enormous power of habit. The young man engaged in mechanical pursuits who is going to do the next job right never amounts to anything. The young man who is determined to do this job right cannot be kept down.

upright 6-in. channels, with diagonal braces made of $3 \times 3 \times \frac{1}{4}$ in. angles. The top chord is also a 6-in. steel channel. The whole side of the car is practically a light bridge truss girder. The spaces between the upright and the diagonal stays is filled with expanded metal which makes a strong and light lining for the car and quite capable of sustaining the weight of a full load of coke.

The light weight of the car is 37,900 lbs. Its maximum capacity is 120,000 lbs. The capacity of the car, when loaded with coke level with the top, is 3,295 cu. ft., or 100,497 lbs. The length inside car body is 40 ft., width 9 ft. 4 ins. Height, from top of rail to top of car body, 12 ft. 6 ins. Height of lowest point of hopper above the top of rail, $13\frac{3}{8}$ ins. The design is patented.

Early Telegraphs.

"The thing that hath been, it is that

lished a remarkable description of the electric telegraph, in the *Scots' Magazine*, under the title of "An Expeditious Method of Conveying Intelligence." In 1760, George Lewis Lesage, Professor of Mathematics, at Geneva, promulgated an invention of an electric telegraph which he eventually completed and set to work in 1774. This system was composed of twenty-four metallic wires insulated and enclosed in a non-conducting substance. Each wire ended in a stalk mounted with a little ball of eider pith and suspended by a silk thread. When a current of electricity was sent through the wire, the eider ball at the opposite end was repelled, the movement designating a letter of the alphabet. By this means words could be spelled out. It was a crude method, but it was a complete electric telegraph system. The reason why this and other inventions of a similar nature never come into general



STEEL HOPPER COKE CAR—VANDERBILT DESIGN.

Vanderbilt Steel Hopper Car for Coke.

The Lackawanna Iron & Steel Company have recently had some 50-ton steel hopper coke cars built from designs made by Mr. Cornelius Vanderbilt, of New York. The cars are composed entirely of structural steel shapes, the side sills are 6 in. channels placed with the flanges inward. The center sills are 15-in. channels placed 15 ins. apart. This space at each end takes the draw gear, and in the center of the car, where it is roofed over, it is utilized for the chain mechanism by which the hopper doors are operated. The hopper doors are three on a side, and when all are lifted for discharge give a hopper opening 14 ft. 6 ins. long. The lower edge of the hoppers have a cross spread of 5 ft. $4\frac{1}{2}$ ins., so that they deliver the coke clear of the rails.

The frame of the car is composed of

which shall be, and there is no new thing under the sun," are the words of Solomon, and they apply with wonderful accuracy to nearly all the inventions of modern times. Very few people would doubt the electric telegraph being exclusively a modern invention, yet experiments were made centuries before the electric telegraph came into use, which indicated that a system of electric telegraphy could have been worked out had the need of it existed. Swenter, in his *Delassments Physico Mathematiques*, published in 1636, described how two individuals could communicate with each other a long distance apart by means of the magnetic needle. In 1746 Le Monnier exhibited a series of experiments in the Royal Gardens at Paris, showing how electricity could be transmitted through iron wires 950 fathoms in length; in 1753, Chas. Marshall pub-

use was that the need for them had not arrived.

Turbine Engines for Atlantic Steamer.

Turbine engines have been used considerably for steamboat power on both sides of the Atlantic, but there has been decided hesitation displayed about using turbine engines in transatlantic steamers. This is surprising, because turbine engines take up much less room than reciprocating engines and the most improved forms do the work with about the same expenditure of coal as quadruple expansion engines.

The transatlantic steamer equipped with turbine engines is coming in the near future. It is to be run on the Allan Line, between England and Canada, and will have a gross tonnage of 12,000 tons and a contract speed of 17 knots. Although this speed is small

compared with that of many of the great transatlantic liners, it will be greater than that of any of the ships of the Allan Line. The traffic between England and Canada does not warrant the expense of a faster ship, but the new vessel will be interesting as the first of her kind.

Why Do Stay Bolts Break?

Mr. John Livingston recently read a paper at the Foreman Boilermakers' convention at Chicago. Among other things, Mr. Livingstone said:

Your chairman produced a board to show 171 heads of stay bolts from the right side of the fire box on the fire-side sheet of a locomotive; at least 75 out of the 171 were burned. You have held that the breakage of stay bolts is due to expansion and contraction, and unable to counteract the expansion and contraction with the solid stay bolt, discussion centered on flexible stay bolts.

it, for iron has capacity to convey to the water the heat it obtains from the fire, however fierce; but if burning is commenced at the inner end of the stay bolt, it will extend outward and imperil the sheet immediately around it. Though riveted close to the plate the inner end of the bolt is only mechanically in touch with the plate, and cannot exercise the functions of the sheet in giving to the water the heat by which it is attacked. The water protects the sheet from burning and the heat passes through the iron to the water. The burning of the inner end of the stay bolts being demonstrated by the burnt ends on the board, it is reasonable to suppose that the flexible stay bolt, which offers more substance to burn, and is, neither in the furnace nor at its joints, chemically in touch to exercise the functions of iron to obtain the protection from, and convey the heat to, the water.

to the bolt, in which the impact of the molecules from the heat and compression, is cushioned in the air passing through the center of the bolt, expanding perhaps three fold between the outer and inner air, from the heat by it taken up in its passage through the center of the bolt, giving a natural elasticity to the bolt.

And, given two locomotives stayed with good quality and equal sized stay bolts, the locomotives put into service in the same locality under the same conditions and equally well cared for, the locomotive with the stay bolt having the hole through its center will endure in service twenty per cent. longer, steam better and burn less fuel.

Within the present week I have seen samples of new stay bolts made like strands of a rope of iron and steel, rolled seemingly homogenous, but when threaded and bent, though showing good fiber, the strands or lamination, whichever you choose to call them, were too open to be appreciated by practical men. Some people make light of a little crystallization. In one of a number of tests which I saw made there was a difference in tensile strength. In a sample a speck of crystal about an eighth of an inch in diameter was cause for loss of 2,640 lbs. in the tensile strength as compared with another test of the same sample where there was no crystal; how much greater must be the breakage in stay bolts from iron which shows an excessive amount of crystal, say, two-thirds, as seen in a sample on the table.



SOME OF OUR FRIENDS AT WELLINGTON, N. Z.

Too little heed was paid to the lesson taught on the board, too little consideration was given to the prima facie fact, that 44 per cent. of the heads of those stay bolts were burned.

When the bolts commence to burn at the inside of the sheet, the burning continues inward until protected by the water. The heat that causes the burning causes expansion at its inner end, and in the hole of the sheet; and that expansion is met by resisting expansion in the sheet, solid against solid, with risk that both the sheet and the bolt will crystallize. The sheet, which may also burn, may crack between the bolts; the bolts will break, not always where the force of rigid compression obtains; sometimes where, by the concentration of force there, the other part of the bolt snaps under the varying vibrations and strains it has to endure. The sheet in ordinary service cannot be burned so long as there is water behind

The Mexican Central System of Railways make answer that they have had 30,000 flexible stay bolts on trial for four years; they tell you they cost more than the rigid bolts; that they are unsatisfactory; that they have just as many broken stay bolts in the flexible, that they find it difficult to detect the broken stay bolts, and that they are renewing with solid bolts as fast as they come to the shops for new boxes, and that for 90 engines now on order they have specified the rigid stay bolt. There is only one way to avert the risk of burning from the inner end of the bolt outward, and that is with air through the center of the bolt and the water around it; nor can you unduly expand a bolt of that character. It will receive the force of the expanding sheet without the resistance of its own power of expansion to the extent in a solid bolt. The impact of molecules from expansion in the sheet is communicated

Getting Work Out of Machine Tools.

There is considerable agitation going on in some machine shops, about how to get full work out of high-speed steel. We think it would be more practical and profitable to agitate in favor of getting maximum work out of ordinary tool steel, for then the tools on hand could be used without change except that of speeding up when necessary. In the ordinary shop old tools and the steel suitable for them have never been properly operated. Instead of complaining that their tools are too weak for high-speed tools, the foremen ought to exert themselves a little more to instruct the men on the proper cutting speed of the tools they have. Tables showing the speed in feet per minute at which metals can be most economically worked are a great convenience and ought to be more in evidence.

One of our subscription agents in Mexico, in sending in his list for the coming year, mentions that two of those who were on his list last year have been murdered and one has gone to the penitentiary for six years.

The Growth of the Locomotive.

BY ANGUS SINCLAIR.

(Continued from page 6.)

Although one of the first railroads for the movement of wheeled vehicles used in the United States was built in

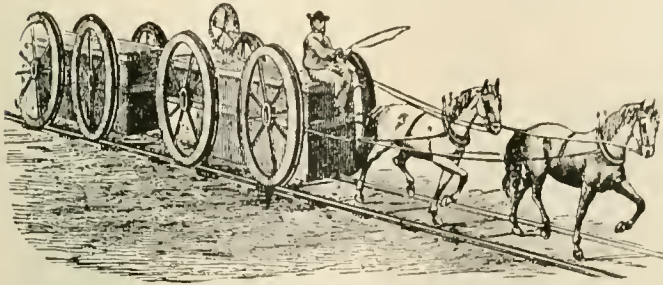

FIRST AMERICAN RAILWAY (THE "GRANITE ROAD").
HOW QUINCY QUARRY RAILROAD WAS OPERATED. 2

New England, that section of the country was not so early to engage in railway building as other parts having less commerce and less population than Boston and its spangled banner of manufacturing towns. The people of New England generally, and of Massachusetts in particular, were by no means backward in recognizing the advantages of good means of transportation, but they had grown to believe that the canal was the proper way to extend inland intercourse. As the construction of canals had come to be regarded as a State enterprise, railroad work was put into the same category, and the good people of Boston and its satellite towns, while wishing for railroad connection, waited for the State to do the work when much less important centers of population elsewhere were helping themselves by subscribing for stock in railroad companies.

Public sentiment in favor of giving charters to private individuals or corporations to build railroads was of slow growth in Massachusetts, for, in 1826, when Gridley Bryant applied to the legislature for a charter to build a short tramway from the Quincy quarries to the Neponset river, vigorous opposition was encountered. Had it not been that patriotic sentiments were excited because the stone was to be used in building the Bunker Hill Monument, it is likely that the charter would have been refused.

The Quincy Quarries Railroad proved to be a good object lesson for New England people, and convinced them that freight could be moved on rails more readily than on turnpike roads. It also taught them that taking the right of way by eminent domain did not take away the palladium of the people's liberties, as they were assured by the opponents of the enterprise would be the case.

The opening of the Erie canal in 1825

gave New York such a generous grasp of western business, that the people of New England were soon agitating for extension of canals that would bring to them the products of the West in exchange for their manufactured goods, and schemes toward that end were agitated that would have rivaled in magnitude any canal enterprise, had they been carried out. One scheme called for the cutting of a canal tunnel through the Hoosac Mountains at an estimated expense of \$1,000,000. The experience in making a railroad tunnel through the same route would indicate that the work would have cost ten times the estimate.

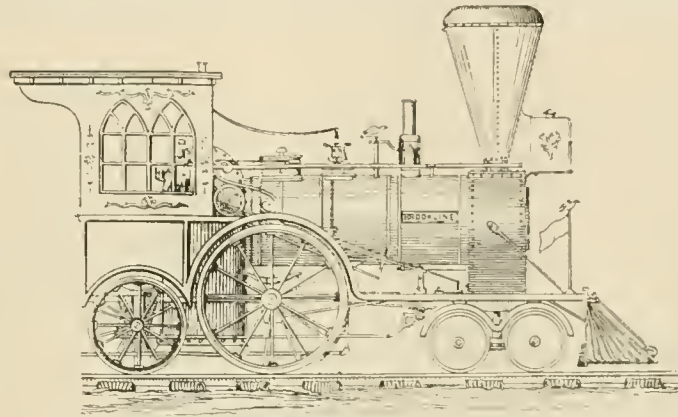

REBUILT BURY ON BOSTON & WORCESTER, 1840.
ORIGINALLY BUILT IN LIVERPOOL 1835.

The New England people had never been very responsive to schemes that called for large expenditures of money, and the canal projects were wasted in the wind of talk.

The legislature gradually came round to investigate the propriety of building railroads. A committee of influential citizens was appointed in 1829, and it made a report which makes curious reading to-day. It recommended:

"That on account of the high price of iron in this country and the abundance and cheapness of granite, the following form of construction should be adopted, namely two parallel stone walls, laid so deep as not to be moved by the effects of frost, surmounted by a rail of granite about a foot in thickness and depth, with a bar of iron placed on top of it of sufficient thickness to form a

track. These stones were to be at a uniform distance of five feet from each other as nearly horizontal as possible and the space between them was to be filled to within six inches from the upper surface of the rail with earth and gravel so as to form a path for the horses employed in drawing the carriages. The board reported that on the railroads recently built and then in process of construction in England and France, it was proposed to use locomotive engines; but the conclusion was reached that coal was so dear in this country and horses and fodder were so cheap, that horse power would be here more economical than steam power. It was stated that it was unnecessary to have the railroad absolutely level, as experience had shown that steady exertion of strength by a horse is more fatiguing than even a greater exertion occasionally remitted."

In a foot note appears the following interesting suggestion: "The labor of the horse may be still further relieved by providing a platform placed on small wheels on which the horse may ride on the long descents. This expedient, singular as it may seem to persons unaccustomed to observe the ease of locomotion on the railroad, is adopted with success on the Darlington

and the Mauch Chunk railroads, and the horses eat their provender while they are returning to the point where their labor is to be resumed."

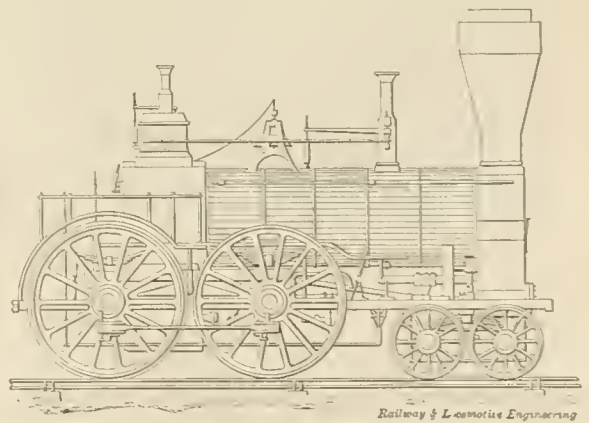

HINKLEY & DRURY ABOUT 1849.

This scheme of building a railroad with granite blocks was by no means absurd, for similar tramways were built in oriental countries long before the Christian era, and some of them are still used in Italy. They have no bar

of iron for the wheels to rest upon, but they have outside ridges which keep the wheels running upon the smooth surface of the granite blocks.

No satisfactory results came from the efforts of the State Legislature to promote railway construction. After a few years' delay railroad building was undertaken by private individuals; railroad companies were formed and construction pushed with vigor that soon put New England abreast of even Pennsyl-

he was a fireman for a short time and was soon advanced to be engineer, a position he held over five years. From that he was advanced to be foreman in the machine shop. While in that position the telegraph was introduced, and nobody at the station being able to operate the instrument, Mr. Richards learned telegraphy, and held the place of telegraph clerk for several years. After that he returned to the shops as general foreman and on the death of

of the Middlesex canal, traces of which can still be seen.

"Of the early locomotives, three were built by Robert Stephenson & Co., Newcastle-on-Tyne—one for each of the above lines; two were built by Edward Bury & Co., Liverpool, England—one for the Boston & Providence, one for the Boston & Worcester.

"The Stephenson locomotive on the

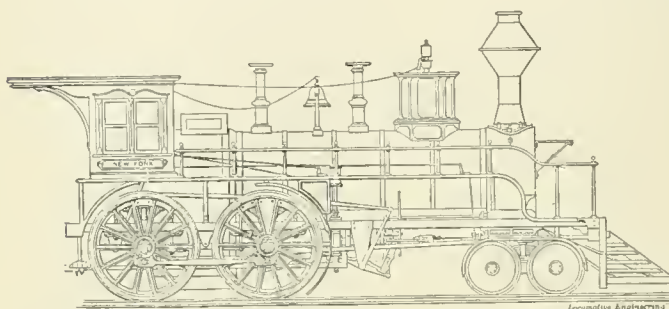

BOSTON & PROVIDENCE, GRIGGS ENGINE, ABOUT 1851.

vania in the promotion of railway enterprises.

In 1830 the Boston & Providence and the Boston & Lowell railroads were chartered, and the year following a charter was granted to the Boston & Worcester. In 1833 the Western Railroad was chartered which was the most ambitious project undertaken by the people of that region. The purpose was to extend that line from Worcester to the western border of the State and connect in New York State with a railroad to Albany. This plan was

Mr. Griggs in 1870 was made master mechanic and remained in that position until after the railroad was absorbed by the Old Colony System. Mr. Richards writes:

"The Granite Railway in Quincy, Mass., was the first railway in New England. It was built in 1826 to convey granite from the quarries to tide water. Much of the granite used for building the Bunker Hill Monument and old Boston was transported

B. & P. was broken up in 1857; the Bury was sold and in service at that time. The B. & P. Co. received three locomotives from the Baldwin Works in 1836.

"The Stephenson and the Bury locomotives had four wheels, one pair drivers and one pair of leaders.

"The Baldwin had one pair of drivers

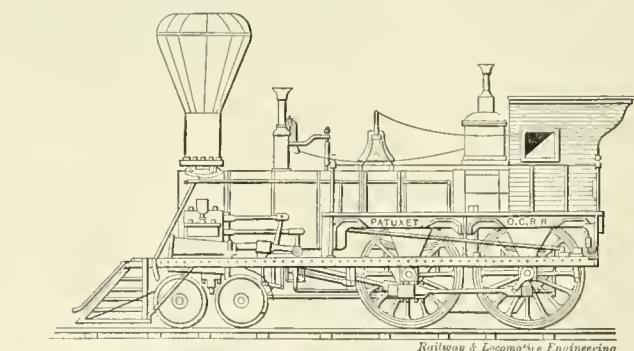

OLD COLONY ENGINE, ABOUT 1850.

Cylinders, 13 x 18 in.; driving wheels, 60 in. dia.; weight, about 17 tons.

eventually consummated and the three links formed the Boston & Albany Railroad.

The subjoined notes, by George Richards, of Roxbury, Mass., tells briefly the story of early railroad building in New England and the kind of locomotives first used.

Mr. Richards was long known to railroad men as master mechanic of the Boston & Providence Railroad, but he had a peculiar career, even for a pioneer railroad mechanic. He went to the road in 1849 as a machinist, then

over this railway. The motive power was the horse and the ox. The grades being favorable, but little was required to move the loaded cars.

"In 1830 three railway companies were chartered in Massachusetts. One from Boston to Providence, to connect there with tide water and steamer to New York; one from Boston to Worcester, which was later extended to Albany, forming Boston & Albany Railway, now a part of the New York Central, by lease; one from Boston to Lowell. This railway was built along the line

and a four-wheel truck. The driving axle was back of the fire box and had a half crank. The main frame was outside of the drivers; the bearings rested on short shafts which projected from the hub of the wheel, so that the driving-wheel shaft was really in three pieces; there were but two eccentrics, and the rods hooked up or down, as the gear was reversed.

"Some locomotives were built on the Boston Mill Dam, now a part of Back Bay District. They were copied from the English, in part.

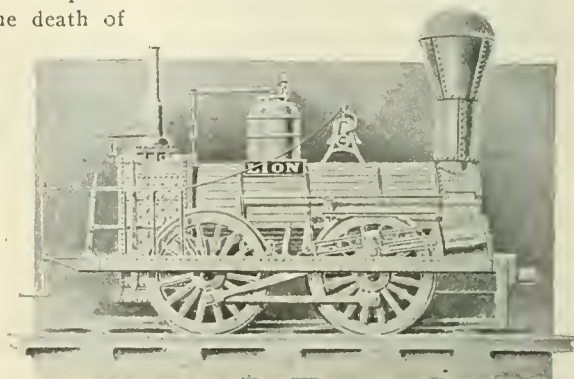

LION, HINKLEY & DRURY'S FIRST ENGINE.

BOSTON AND WORCESTER RAIL ROAD.

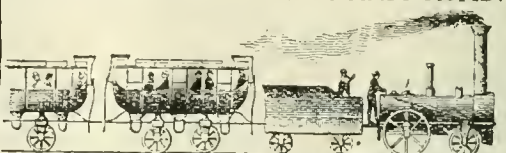

THE Passenger Cars will continue to run daily from the Depot near Washington Street, to Newton at 6 and 10 O'clock, A.M. and at 3 1/2 O'clock P.M. and Returning, leave Newton at 7 and a quarter past 11 A.M. and a quarter before 5 P.M. Tickets for the Passage either Way may be had at the Ticket Office, No. 617 Washington Street, Price 3 1/4 cents each, and for the return Passage, of the Master of the Cars, Newton.

By Order of the President & Directors
a 29 Epifts F.A. WILLIAMS, Clerk.

OLD RAILWAY TIME-TABLE.
NEW ENGLAND TRAIN IN 1834.

"The Locks & Canal Co., of Lowell, was formed to do work for canals. After the locomotive had killed and buried the canal, they took up locomotive building, and turned out at last some good work. Some of their first engines, like those of other builders, were far from perfect.

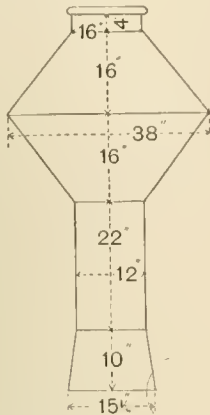

FIRST DIAMOND STACK EVER MADE.
Designed by George S. Griggs, of
Boston & Providence.

"One on the B. & P. engines had four drivers, was outside connected, a short four-wheel truck, which placed the cylinders high up, and caused much rolling and side motion.



GEORGE S. GRIGGS.

"The first master mechanic of the B. & P. was George S. Griggs, who continued in that service up to the time of his death in 1870. The first train was run on the B. & P., but the first through train was to Worcester, 1834. On account of the Canton Viaduct not

being ready, trains were run on each side and the passengers transferred.

"The Canton Viaduct was, for that time, a perfect job. It has stood the test of seventy years' service, and may endure until the flying machine takes the place of the railway.

The distance is now covered in one hour, with no stops. A saving of ten minutes in time to the public after fifty-four years!

"The boiler of the old Norfolk, for that was the name of Mr. Griggs' first locomotive, was of iron. It was



EARLY RAILWAY TIMES.

"Mr. Griggs built his first locomotive in 1845. This locomotive had four coupled drivers and a four-wheel truck. Cylinders, 14 3/4 by 18 ins.; drivers, 4 1/2 ft. diameter. It had a crank axle of wrought iron. The valve gear had four drop hooks. Under each hook was a runner which rested on a half round cam so that turning the cam

straight on top except where the barrel joined the fire box with an angle-iron connection. The dome was forward, in which was the throttle. The man hole was over the fire box. The throttle stem was pushed in when working steam, and there was no danger of the throttle flying open. The tubes were of copper, 1 3/4 ins. outside,



EARLY RAILWAY TIMES.

shaft would lift two hooks and drop the other two.

"The hooks moved the valves by means of a rocker to the top arm of which the valve stem was jointed. The point of cut off and exhaust could not be varied, but by means of lap and lead in the right proportion, and high speed was attained.

"In 1849 the fastest train to Providence was in one hour and fifteen minutes, including one stop of five min-

and 10 ft. long, with wrought iron thimbles. In later practice cast iron was used.

"The frame, of two bars, 5x5 5/8 ins., and one 2x2 ins.

"The pedestals, or jaws, were of cast iron, with tennons at the top. The cylinders were cast with flanges on both sides. The flanges on the inner sides to hold them together by means of a casting which formed the center pin for the truck.

"The flanges on the outside of the cylinders were bolted to casting which was riveted into the frame.

"The tender was mounted on three pairs of wheels and had no swiveling truck. This style of tender was used many years, and there was less flange wear on the wheels than with the swiveling truck. With extra long tender, the case would be different.

"Tires, weighing six or eight hundred pounds were heated and shrunk on without the aid of crane, derrick, or falls. Car wheels were keyed and pressed on by devices worked by hand.

"In 1856 the wood block linings were applied to driving wheels with success, and were used on several railways.

"The frogs on the early railways were of cast iron, and wore very fast. Mr.

a coarser netting, which was soon followed by the diamond chimney, an invention of Mr. Griggs. The grates were made to rock and dump.

"The first cars were on four wheels with doors at the sides. Later, frames were made, two of the short bodies placed on the frames, a four-wheel truck put under each end, making an eight-wheel car. This was soon followed by the modern car."

(To be Continued.)

Railroad Revenues of a Year.

The seventeenth annual report of the Interstate Commerce Commission transmitted to Congress recently, shows that the preliminary income account for the year ending June 30, 1903, gives railway returns for 201,457 miles of line, which is approximately 98 per cent. of the entire mileage in the United States. Gross earnings for that year amounted to \$1,890,150,679, or \$9,382 per mile of line. Operating expenses aggregated \$1,248,520,483, or \$6,197 per mile, leaving net earnings of \$641,630,196, or \$3,185 per mile. Fifty-three million dollars in taxes are not included in this statement of operating expenses. Compared with the previous year the net earnings are greater by some thirty-four millions and stock dividends are greater by nearly ten millions. In 1897 the gross earnings averaged only \$6,122, and operating expenses \$4,106 per mile of line.

People who think of subscribing for RAILWAY AND LOCOMOTIVE ENGINEERING



EARLY RAILWAY TIMES.

"When the Taunton Locomotive Co. commenced business they followed close after the B. & P. pattern of locomotive for several years; Hinkley & Drury did about the same thing.

"Mr. Griggs built locomotives at B. & P. shops as long as he lived and when more were needed than he could furnish, locomotive builders built them. He took up all real improvements as fast as they appeared, increased the capacity to meet the want of more power, and was never behind the times. In 1852 he built locomotives with link motion valve gear and soon changed all the old locomotives to the then new valve motion. All small fittings such as safety valves, gauge cocks, cylinder cocks, blow-off cocks, tank, and supply-pipe cocks, pump valves, whistles, etc., for the earlier locomotives, were made with inferior tools, which, to-day, would be worth scrap price, less cost of breaking up.

"Driving-wheel tire flanges were shaped with a hand tool. Taper fits of piston rods were after made with a hand tool. Screw threads were, for the want of dies and screw lathes, often made with hand tools on the catch-up plan.

"For many years all eccentrics were keyed on the shaft before the wheels were put under the locomotive, thus insuring the right position. In case of a change of lap or lead of valves the eccentrics were moved to the new position. An offset key was put into the keyways and the job was done.

Griggs plated them with cast steel, and I think that he patented the device.

"Previous to 1857 locomotives in New England used wood for fuel, and the price became so high that the roads must find a substitute or go out of business.

"Soft coal was tried on a locomotive, 16x20 in. cylinders, 5½ ft. driver, and it



EARLY RAILWAY TIMES.

was a success the first day. A shelf of cast iron was placed across the furnace under the tubes and filled with fire bricks; not being very durable, an arch of fire bricks, 2x4x8 ins. was substituted. This was soon replaced by the brick arch as it is used to-day.

"The chimney used at first was the old wood burning arrangement with

in the near future ought to begin now. They can now begin and receive the numbers for the whole year, which they will probably want to bind. We frequently receive subscriptions in the middle of the year with the request that they begin with the January number. Some of the numbers nearly always prove to be out of print.

General Correspondence.

Cylinder and Valve Lubrication.

In your December issue, a locomotive runner wanted to know something about the proper lubrication of valves and cylinders and the best make of lubricator, or one that will put oil to valves and cylinders when engine is working steam. According to my judgment, based on twenty-three years experience as a locomotive runner, that if engine is properly handled it requires but very little valve oil to keep engine in smooth working order. Does the "Runner from Galesburg" think that oil fed to valves and cylinders when engine is working steam, spreads out over the walls of cylinders or the working surface of valve and seat, the same as it would if the engine was drifting. The oil mixes with the steam or in other words the steam is the lubricant, and wherever the steam goes, whether to cylinders first or last the lubricating particles of steam are not diminished. The time the valves and cylinders really need oil is when engine is shut off, or drifting for at that time the valves and cylinders are in direct communication with smoke box, no matter if you have relief valves in steam chest, and if you have none, so much the worse for valves and cylinders. To have a smooth working engine, one that won't say, "I guess I will," or "I guess I won't," is to keep all foreign substances out of steam chest and cylinders, a slush of wet steam on valves when engine is starting to take a run for a hill will set reverse lever a jiggling, and there you are, the lubricator or the valve oil has got to stand the brunt of it. Now, if I tell you something you already know I won't charge you anything for it. My way of taking care of valves and cylinders, is just before I close the throttle I have the blower valve opened just enough to carry the smoke clear of stack; by so doing with aid of relief valve in steam chest you will keep valves perfectly clean from smoke-box end; by following this practice, if your pistons run black and gummy, you will soon find they will clear up and get bright and smooth.

The piston indicates the condition of cylinders, in switching or when engine is working steam for short distance the blower should be lightly on all the time. If the fireman pumps the engine he should be given to understand not to carry over a half glass of water at any time, the half glass is allowed for, when engine is not working steam. If you consider my way worth trying you will find most any lubricator will do. Give

valves a good oiling before starting on your trip, then cut lubricator down just as fine as it will work; you need have no fear, reverse lever will give you timely warning if the valves are not getting oil enough. Just for an experiment I made a ninety-five mile run without giving valves a drop of oil from lubricator or otherwise. I gave each side about two tablespoonsful at Union Station before starting, then shut off lubricator, intending to see how far she would go; and to my surprise and satisfaction she made the entire trip, and I believe she would go on indefinitely if there were no stops long enough for cylinders to cool below their working temperature.

AN OLD TIMER OFF THE "Q."
Terre Haute, Ind.

be awarded for the best time made. The competition on the passenger run was between the "Addison Gilmore" from the then Western Railroad; the "Nathan Hale" (Wilmarth) from the Boston & Worcester Railroad; the "Union" (Hinkley) from the Fitchburg Railroad, and the "Neponset" (Griggs) from the Boston & Providence Railroad. And the result was in the order I have just given. The highest speed attained was that by the "Gilmore"—47 miles per hour, and the next, 45 miles per hour, by the "Hale."

The freight trial was between the "Milo" (Hinkley) from the Boston & Lowell, and the "Highlander" (Griggs) from the Boston & Providence, both six-wheel freighters, without trucks. And



EARLY RAILWAY TIMES.

Locomotive Tests at Lowell in 1851.

I comply with your request, although I am a poor, old, frost-bitten withered apple, hanging on the branch long after the better harvest has gone into the barrel, and perhaps elsewhere.

So then. The Wilmington trial of competition was had, I think, in the September of 1851, and if it was not as scientific as the modern fad of running a locomotive with jacked-up wheels, it was probably quite as satisfactory.

There was a piece of disused road, now forming a part of the Wilmington and Lowell branch of the Boston & Maine Railroad. The length was about ten miles, and the various roads in this part of the country were invited to send representative engines to run over the course—the passenger engines, with ten full cars, and the freight engines, with one hundred, short, light, four-wheeled cars, loaded with stone—the prizes to

the "Milo" bore off the honors, although Mr. Griggs was inclined to believe she didn't.

And the practical result of the trial was extremely gratifying—like a good many of our more modern fashions of determining the capacity and value of locomotive engines.

For the "Gilmore," with her single pair of seven-foot drivers, very soon disappeared, to be reproduced as an ordinary eight-wheeler, while the others served for many years, the "Neponset" outlasting them all, while the "Highlander," which Grandpa Griggs refused to believe vanquished in the Wilmington trial, outlived the "Milo" by many years, and survived long enough to upset a Hinkley engine and kill three men, while herself and her crew stood impassive amid the ruins.

And now having answered your letter according to your request, I desire to

add that your excellent periodical, which I have taken from the start, grows better with each fresh issue—in which respect it is entirely unlike the modern locomotive.

GEORGE H. LLOYD.

Boston, Mass.

What Should Be the Maximum Economical Load for a Locomotive.*

What should be the maximum economical load for a locomotive?

This is a question that is probably interesting as many railroad men at the present time as any we might mention. The unparalleled rush of business, the shortage of power, the lack of sufficient cars in which to transport the freight offered for shipment, all combine to make the question one of primary importance.

There seems to be quite a diversity of opinion among railroad men regarding the load that should be given a locomotive, some contending that it is most economical to make the load all that can possibly be hauled between terminals, governed by the limiting grade; others argue that it is more economical to give a lighter load and consume less time between terminals.

In determining the economical load for a locomotive, one of the most important factors to be considered is time. For instance, if we simply compare the performance of two single trips, one with the maximum load, and the other with a lighter load, the maximum load may be the more economical, revenue and all cost of transportation considered, notwithstanding the locomotive may burn double the amount of the fuel, and the wages of trainmen be twice as much as with a lighter load.

It is not many years since it was almost the universal custom to limit the load for a locomotive to a certain number of cars, regardless of their capacity or contents. This, of course, was a very indefinite way of getting at the proper uniform load that could be hauled. Later, as business for the roads increased, operating officers were at their wits' ends to devise ways and means for getting the freight over their lines. The cars were made larger, as it was found by experiment that the resistance per ton of a large capacity loaded car was much less than a loaded car of less capacity. Then the method soon came into use of making the load for a locomotive a certain number of tons, including weight of the cars as well as their contents. This proved of considerable advantage, as the reports soon showed that the same locomotives were hauling a greater average tonnage of revenue freight.

The hauling capacity of the various

*Paper by Chas. T. Noyes read at Pacific Coast Railway Club; abridged.

locomotives then became an important question, whether it should be based on the tractive power, the adhesion taken at one-fourth the weight on driving wheels, or at one-fifth the weight, or some fraction between the two. Tests were made on various roads for the purpose of ascertaining just what a certain locomotive could haul on certain grades, and under other known conditions. The results thus obtained, usually under the best possible conditions, proved in many cases to be misleading, as often the maximum load hauled in these tests was adopted as the regular rating. While a locomotive might haul a certain load under excellent conditions, it was soon found that, if the locomotive was given this load in regular service, numerous failures followed, and in a short time the engine would be in the shops for general repairs.

Some will contend that a locomotive should be given a load that it will haul comfortably, make the schedule time, and consume the minimum amount of fuel commensurate with the load. This would be well enough if we were simply to consider comfort in handling the traffic, but it does not follow that it would be the most economical, all conditions considered.

If we consider the cost of fuel as the basis for economy in a locomotive's service, then the load should be somewhat less than the maximum that could be hauled, for, taking the average locomotive now in service, there is a certain load with which it will do its best on fuel. It is that load under which it can make the schedule time and maintain the full pressure of steam, without forcing the boiler.

The assertion is often made that, if an engine has the maximum load it can haul, it will burn an excess of fuel, and will soon go to pieces and into the shops for repairs. This is no doubt true with many of the locomotives at the present time in use. But the question arises, and I think it is a pertinent one, "Why should a locomotive fail, or, in railroad parlance, 'fall down,' because it has its full load?" If a locomotive is properly designed, should it not be able to haul its maximum load without any failures until the time it has to go into the shops for general repairs, which ought not to be more than once in two years, and then only on account of its wearing parts?

Take the list of engine failures on the average railroad, and there are not five in fifty that ought not to be avoidable. These forty-five failures will be found to have been caused, hardly without an exception, by some one's want of care at the proper time. This want of care may have been in designing the locomotive, or in its maintenance when in service, or it may have been carelessness of some one when the engine was in the shop

undergoing repairs, or it may be that the enginemen, through having been overworked, neglect just the little extra inspection while on the road that insures their engine against failure. Boiler failures, probably with hardly an exception, are caused by want of the proper care at the right time.

There never has been a time in the history of railroading when the service required of a locomotive was as severe and exacting as at the present.

In view of this fact—

Are we designing our locomotives to successfully meet these exactions?

Is our inspection at terminals as rigid as it should be?

Are we giving the boilers that additional care that they should receive when working subject to the severe conditions under which we expect them to run without failures?

Are we using the proper appliances so that the fuel may be burned without injury to the fire boxes or other parts of the boiler?

Are the firemen properly instructed as to the proper method of taking care of their fire so as to avoid injury to the boiler, and if so, are they rigidly required to follow these instructions?

Are the engineers conscientious and faithful in strictly reporting all defects apparent and suspected, when they come in from their run?

Do the roundhouse foremen give attention to these reports, and see that every apparent defect is remedied and all suspected troubles looked into and corrected, if found necessary?

Are all officials who have to do with the maintenance of the locomotives alive to the fact that, under the system of "pooling," and the loads required to be hauled at present on many roads, the duties appertaining to maintenance are much greater than they were under the old system of light loads and the single crew?

In other words, is the motive power department keeping up in the matter of design and maintenance to the ever-increasing requirements of the conditions of traffic?

If all these questions could be answered strictly in the affirmative, we should not only have a locomotive that would haul the maximum load possible, but do it without failures and with the greatest comparative economy, all conditions considered except time. In some cases the time factor would make no difference, but ordinarily this is the critical factor.

Regarding all expense of maintenance, without doubt that of the lighter train would be the most favorable. The liability of engine failures would be lessened, the locomotive would be in service more continually, the most of repairs would be much less, the time between terminals

could be materially shortened, which alone would tend toward economy, there would be fewer car failures, and, not least important, would not require the power that would be necessary with the heavier trains. To these might be added the satisfaction to all concerned, the motive power department in particular, of being able to operate the trains without the continual series of engine failures resulting in the shops and yards being crowded with engines undergoing and awaiting repairs. For, until we have designed an engine that will haul its maximum load without failure, we must count on the service of the average engine as now designed.

There is no doubt but what the time factor is the critical one, and it would appear that this is not always as carefully considered as it should be.

To illustrate the probable economy that would be shown, we will suppose a case which will be near enough to actual conditions existing on some roads that it will be possible to make a comparison between the assumed and the actual conditions. The regular passenger train time between the terminals on a certain road is, say, 7½ hours. This, on account of heavy grades and time lost in stops, makes the running time about 17 miles per hour. The freight trains running between these same terminals consume from 12 to 15 hours, nearly one-half of which is lost waiting on sidings. One of the regular freight engines, with very nearly its maximum load for the limiting grade, will make the run between the terminals in 7 hours. We will assume that this maximum load is 450 tons, and, for convenience, consider that this represents 9 cars loaded. With the load of 9 cars, and from other causes, it takes 11 hours to make the run. With 1 car less, the run can easily be made in 7 hours. If there are 6 trains each way every 24 hours, in one case it would require 8 engines to haul 108 cars, and in the other, 6 engines to haul the 6 trains each way, but would haul but 96 cars, this allowing plenty of time at terminals.

In the first case it requires 1 engine to haul 9 cars, and in the other, 1 engine handles an average of 16 cars per day. This in 30 days would amount to 210 cars in favor of the 8-car train and shorter time. And the most important point is that the same number of cars are hauled by nearly 16 per cent. less power. The latter would be of much consideration on roads where there was a shortage of power to move the cars. The lighter train would not only result in increased revenue freight hauled, but there would be a very material saving in fuel consumed per ton mile, as well as less paid in wages for overtime of trainmen.

We also find in this illustration that

the heaviest load is not the most expeditious method of handling traffic.

It is usually the custom on most railroads to make the schedule time of freight trains much slower than passenger trains. We can readily understand why this might be necessary when the time of the passenger trains is fast, and also in the case of way-freight. But in runs where the time of passenger trains on account of grades is reduced to a speed of fifteen or twenty miles per hour, there seems to be no good reason why through freights can not have the same schedule time as the passenger trains.

Between terminals where there is but a single track, or where the traffic is liable to become congested, doubtless having a common schedule time for all regular trains, with the exception of perhaps way freight, would simplify the problem very much of the expeditious handling of the traffic.

There is a dearth of data relative to experiments that have been made to determine the most economical speed for freight trains, but the results of such experiments as have been made to determine this point indicate that a speed of from fifteen to twenty miles per hour is more economical than slower speeds. This would more properly apply where the limiting grade is nearly continuous or practically so.

As long as the requirements of service necessitate the "pooling" of the engines on any road, the lighter load would tend favorably toward fewer engine failures; at the same time, as far as failures are concerned, the single crew would make a greater difference than a variation of load.

Again referring to the load, it is evident that, in determining the economical load for a locomotive, each engine run should be considered independently of the others. If the limiting grade between terminals of an engine run is short, and the remainder of the run comparatively level, then the economical load may be the maximum that the locomotive can haul over the limiting grade, present conditions of weather and track considered. When the limiting grade is continuous, a lighter load would doubtless be the more economical.

In conclusion, making our deductions from what we have in evidence, and taking into consideration the conditions as they are usually on a railroad, it is evident that the maximum load is not the most economical, except in cases where the limiting grade, governing the given load, is short.

That the time factor is one of the greatest importance in determining the economical load.

That, in determining the hauling capacity of a locomotive, on account of the wide variation of the ratio of cylinder

power to the weight on driving wheels of the various designs of engines, it would be better to use a certain per cent. of the weight on drivers, rather than the calculated tractive power.

That, while we recognize the importance of a locomotive always being given its rated economical load, and that under the usual conditions affecting traffic it is not possible to do so, at the same time it seems evident that, in the successful movement of cars it is of more importance that the proper schedule time be maintained.

Answer by W. H. Sheasby.

Following is the substance of Mr. W. H. Sheasby's article on the subject, "What should be the economical load for a locomotive?" It refers to Mr. Noyes' paper read before the Pacific Coast Railway Club at the December meeting.

Modern theorists seem to have chosen the term "economy" as a word to conjure with, since in its sacred name we have witnessed losses and lasting hurts to railway interests of such startling magnitude as to cause the truly loyal man to question the sincerity of those who profess to work miracles in its interest.

We have witnessed the deliberate reversal of sound laws of business economics and the painstaking defiance of well tested standards for securing maximum results from the minimum expenditure of energy, and we have seen those who have had the audacity to make radical departures from well-proven laws of economical procedure the rule of action brought to the front and voted successes—at least for a time.

The method which made the question of economical transportation a most important one was in no sense strenuous, neither was it a business method, since it gave an engine 30 cars of pig iron for a train to-day, and 30 cars of straw hats to-morrow, because a car was the unit of calculation. The exercise of but ordinary ability would have relegated this crude method to oblivion. The real danger existed at the parting of the ways. It was plain that no plan could fail which would fix for several engines an assemblage of ton units as the trains they should haul, because that would eliminate the guessing feature and would secure a maximum revenue performance. The work was just begun, however, when the old plan was abandoned for the new, inasmuch as the real test rested in determining just where the magical word "economy" should be written.

Up to this time the transportation officials were able to account for results in schedules and in maintenance

of power, and, being chosen for their expertness in such matters, engine failures were of rare occurrence, and traffic officials could offer reasonable assurance of contracted time—all of which used to be counted essential until the apostles of the new thought, by a few deft strokes of the pencil, abolished such trifling considerations.

That some one at the parting of the ways drew the angles too sharply is abundantly attested by the soul-racking records of engine failures which make life a burden to both traffic officials and enginemen. This mistake has put approximately 40 per cent. of the power out of commission and drawn the other 60 per cent. very near the verge of collapse. Traffic men have been driven to distraction through the repudiation of old agreements by shippers on account of the repeated failures of time contracts. Schedules have been demoralized and, in consequence, thousands of dollars have been paid to train crews for overtime, thousands of dollars have gone to pay for premature repairs to locomotives, and thousands more for unnecessary damage to other classes of rolling stock. A further consequence of this mistake is the spirit of criticism, satire and pessimism which now permeates the highest intellectual service in the world.

The secret of the trouble lies in the fact, supported by a hundred proofs, that the straining point instead of the economical point was chosen at which to fix the engines' burden. The economical load for a locomotive, as for a horse or man, will always allow for a margin of unemployed energy. It is the defiance of this fundamental truth that has brought confusion swift and sure in the wake of the modern interpretation of the term "economy."

If those responsible for this burden could plead in extenuation a lack of experience and reliable information to guide them in their commendable determination to right a wrong, we might pass through the throes of evolution sustained by the reflection that time always shows the honest evolutionist his error; yet the entire history of the new departure shows at every point of observation a loyal element in the service whose quick perception spoke its modest note of warning of certain loss if the straining point hypothesis was not abandoned, yet, through steady disregard of its protests this magnificent loyalty is fast lapsing into the silence of callous indifference.

Any system of engine rating must fail unless it enables the transportation arm of the service to maintain such a standard of performance as will secure the good will of the shipper.

I note in Mr. Noyes' able paper that

he asks "Why should a locomotive fall down because it has its full load?" The hypothesis on which this question is based must determine the answer. If by a full load we are to understand a load which taxes the engine to the straining point, there is every reason why the engine must fail long before the legitimate time for it to enter the back shop; but if we are to understand by a full load one which takes into account the hundred service conditions which the "cut and dried" engine test never involves, there is no reason other than mechanical, and, consequently, remediable, why the engine should fail. If this discussion is to be carried to its limit of profit in an honest aim at the good of the service, and if proper recognition is to be given to practical knowledge as to just where the word "economy" should be written, all existing perplexity will vanish from the issue. It is absolutely unthinkable that 50 years' combined research by our country's most brilliant mechanical talent should produce nothing more rational than excessive engine rating.

The endorsement of these evils by the new Daniel has discouraged practical research and perpetuated every element of perplexity that has appeared in the issue and has established conditions which tend to nullify and discredit the best mechanical skill of the day. These conditions are such as would send to early bankruptcy the best business houses in the country. There is no single thread in the entire commercial fabric that could stand the strain of the mistakes of the apostles of the new theories of railroading. There has been jugglery perpetrated on the profession of railroading in the name of economy that has frequently caused me to feel toward such methods as Lincoln felt toward slavery, when he said, "If I ever get a chance to hit that thing, I'll hit it hard."

I am prepared to show that, given a good class of simple engine with reasonable load limits and assuming 90 per cent. of the power at work, the perplexing congestion of traffic need never occur, and I wish to add that under such conditions the refrigerated fruit shipments from California to the eastern markets would increase 50 per cent. from present figures.

Mr. Noyes' able presentation of the case shows what practical men have long been familiar with, that, cutting out the question of destruction of power under the straining load limit, the contention for excessive rating obtains only for the initial trip, after which the showing is so overwhelmingly against it as to make its immediate abolishment a question of financial expediency.

Setting aside every question of sentiment and comfort in operating, there comes from the spirit of commercialism, which we must recognize as the dominating factor in all railroad operations, a call for the recognition of that spirit of loyalty among employees of differing rank and degree which may always be depended on, if correctly handled, to shield from loss the interests of their profession.

Old Engine "Franklin."

In searching for information about historical locomotives we have had to call on many people for assistance and we gratefully acknowledge many favors rendered. The annexed letter is a sample of many received.

TREASURY DEPARTMENT,
STATE OF NORTH CAROLINA.

Raleigh, Jan. 11, 1904.

Mr. Angus Sinclair, New York City.

My Dear Friend:—Considering that you have on more than one occasion proved your friendship for me, I am afraid that you will think I have been negligent in not answering your letter sooner concerning the engine "Franklin" that I ran on the Raleigh & Augusta Railroad in 1876. There are several reasons why I have not written you sooner. The first and greatest is, that I have hoped against hope to secure you a good photograph of said engine. I know that there were a great many taken, but unfortunately I have lost those I had, and although I have written five or six letters and have seen personally five or six people, I have so far been unable to find one. I wrote to Jno. G. Justice, foreman of the shops at Waycross, Ga., and from his letter I suppose he has already sent you one, but it was not clear on that subject. I did run the "Franklin" just after she was overhauled on the construction train laying the track, which is now the main line of the S. A. L. from Cameron to Hamlet in this State. The "Franklin" had a twelve-inch cylinder with a twenty-six inch stroke inclined cylinder. I think she was built the year I was born, in 1854. She originally had an independent cut off, but when she was overhauled, just before I took charge of her the hook and eccentric for the independent cut off was taken off, and she was left a plain hook motion engine. The reverse lever was also done away with, and the end of the reverse lever reach rod had three notches filed in it, which dropped into a steel plate that was bolted on the cab. The handle was an iron handle exactly like the handle of the damper rod, except very much larger. When the engine was in forward gear, the cab seemed very empty, as there was no quadrant or reverse lever

by the engineer's seat, and this handle was up against the front of the cab. When she was out of gear the rod was drawn back so the handle was about opposite the engineer, but when she was in back gear, the great long limber handle came back to the edge of the cab, and if the engine was run fast over bad track, vibrated and swung sideways, and was a decided nuisance. She was equipped with two old Norris ball-valve pumps. In fact there were no injectors on the Raleigh & Gaston or Raleigh & Augusta road, which now form part of the S. A. L.

I forgot to say that this engine was built in Philadelphia and was a Norris engine. She was a wood burner, and never changed to coal, and had an old fashioned balloon wood burner stock with old fashioned cone and petticoat. Her wheels, I think, were about forty-two inches, but of that I am not certain. They were very low, and she was without doubt the strongest engine for her inches that I have ever had the pleasure of running.

I remember losing the dies out of the hooks, and in those days we did not come to the shops often, I remedied the defect by making dies out of hickory, using a piece of an old axe handle, which wore for months, just as well as the hardened steel dies that were lost. This road sold it to the Meherren Valley Road, and the last time I saw her, she was standing on their track near the Virginia line dismantled.

I am sincerely sorry I cannot give you a more accurate description of one of the engines that stood more hard service and did more hard work for her cost and inches, than any I have ever known. If I hear anything else from any of the men, or can remember anything I will write you a supplemental letter to this.

Assuring you of my high regard, and wishing this to be the most prosperous year of your life, and sincerely hoping that you will again ask me to do something that I can do more satisfactorily to both than this, I am

Your friend,

B. R. LACY.

Slipping When Shut Off.

In reply to your request for a reply from your readers in regards to engines slipping when shut off, I will say when I was firing I know of four engines that slipped while shut off drifting down hill, and one engine in particular sprung two sets of journals before they discovered the cause of slipping, when shut off in all the cases. They were eight-wheel engines. In the last case they thought it was too much counterbalance, and they took out 100 lbs. of counterbalance,

but the engine slipped just the same; the last time they gave engine new pins all around and two new journals; engine did not slip any more; they found the engine was quartered wrong in the first place, which I think is the cause of all engines slipping when shut off. Hoping this information will be of some benefit to your readers, yours respectfully,

Oswatonic, Kan.

C. J. VEIG.

I see in this month's magazine of an engine that slipped going down hill shut off, and stripped herself. We have an engine here, a 10-wheel, 19x24, No. 303, that slips going down every hill on the division after attaining about a twenty miles per hour gait. I was on her a few days ago and she slipped in this way, and I would set the straight air brake (which she is equipped with) and

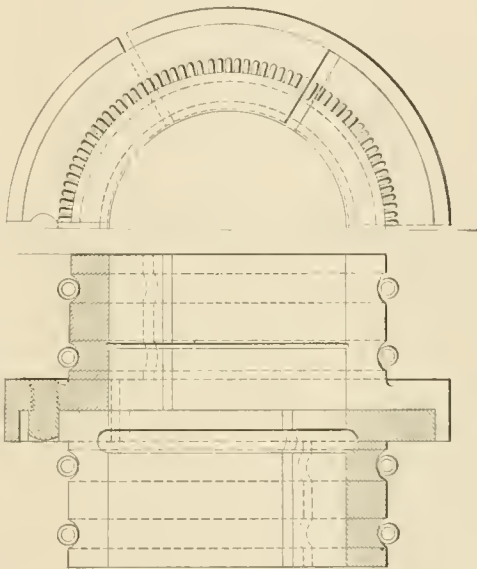

SELF ADJUSTING PISTON PACKING.

it would stop it. It is over weight in her counterbalance that does it, I think.

A. H. KELLEY,

Engineer, L. E. & W. R. R.

Tipton, Ind.

Self Adjusting Piston Rod Packing.

The engraving is of a self adjusting piston rod packing used between the cylinders of the tandem compounds. It was gotten up some twelve months ago by Mr. Metzger, the pit foreman. After it was given a thorough test it proved without doubt to the officials of the Northern Pacific Railway that it met all requirements, and it was accordingly approved by them and adopted as the standard packing for the road.

The simplicity of it and the coil springs around the outside having an even tension, makes it appear at a glance to be of much importance.

This packing is held in a counterbore in the front of the intermediate head by

a cone-shaped follower bolted to the head, the counterbore being a shade deeper than the thickness of the flange on packing.

JOHN W. PERCY.

South Tacoma, Wash.

First Boiler Head Stand.

On page 40, of the January issue of RAILWAY AND LOCOMOTIVE ENGINEERING, it is stated that the "first stand for locomotive boiler attachments that used only one hole in the boiler was invented by F. D. Childs, superintendent of the Hinkley Locomotive Works, in 1881."

This is not good history. Jacob Johann, M. M. of the Wabash Railroad at Springfield, had adopted the best one the writer has yet seen of what was nicknamed "Soda Fountain" for locomotive boilers. This was in general use during 1877 and 1878. His draughtsman was G. D. Brooke, who has since been well known in the mechanical departments of several railroads in and around Chicago who can and probably will verify the above statements. I write this for the purpose of seeing justice partially done my old and honored friend, Mr. Johann.

HENRY F. COLVIN.

A Prophecy That Failed.

Prophecies of what railroad companies will do with their property do not often come out true. This has struck us on reading an article about the Boston & Providence Railroad in an early number of "Poor's Manual." The article begins: "The original charter incorporating this company was approved in 1830, and by its authority was given to construct a railroad from Boston to the State line of Rhode Island, and thence with concurrent sanction of the Legislature of that State, to Providence. The company has been uniformly successful in its operation since the road was opened for traffic, and such minute attention has been paid to the wants of the traveling and shipping community that the Boston & Providence Railroad enjoys the enviable position of being one of the most popular New England railroads. There are abundant satisfactory indications that a wise policy inaugurated in the infancy of the railroad will be permanently perpetuated, and that no consideration will induce the directors to deviate from a course identical with the best interests of their constituents."

Yet the offer of 8 per cent. interest on the stock which was earning considerably more was sufficient to induce the stockholders to turn over the control of the property to a big corporation.

Railway and Locomotive Engineering

A Practical Journal of Railway Motive Power and Rolling Stock.

Published Monthly by

ANGUS SINCLAIR CO.,

174 Broadway, New York.

Telephone, 984 Cortlandt.

Cable Address, "Loceng," N. Y.
Glasgow, "Locauto."

Business Department:

ANGUS SINCLAIR, President.
FRED M. NELLIS, Vice-President.
JAMES R. PATERSON, Sec'y and Treas.

Editorial Department:

ANGUS SINCLAIR, Editor.
F. M. NELLIS,
GEO. S. HODGINS, } Associate Editors.
JOS. A. BAKER,

Advertising Department:

Eastern Representative, S. I. CARPENTER, 170 Summer St., Boston, Mass.
Western Representative, C. J. LUCK, 1204 Monadnock Block, Chicago, Ill.

British Representative:

THE LOCOMOTIVE PUBLISHING CO., Ltd., Amen Corner, Paternoster Row, E. C., London.

Glasgow Representative:

A. F. SINCLAIR, 7 Walmer Terrace, Ibrox, Glasgow.

SUBSCRIPTION PRICE.

\$2.00 per year, \$1.00 for six months, postage paid to the United States, Canada and Mexico. For other parts of the world, \$2.50 or ten shillings. Single copies, 20 cents. Remit by Express Money Order, Draft, Post Office Order or Registered Letter. Mailing address can be changed as often as necessary—always give old and new address, and if you subscribed in a club, state who got it up.

Please give prompt notice when your paper fails to reach you properly.

Entered at Post Office, New York, as Second-class mail matter.

Copyright by Angus Sinclair Co., 1904.

For Sale by Newsdealers Everywhere.

Machine Tools.

"Man is weak of himself and of small stature," says Carlyle, "he stands on a basis, at most for the flattest soled of half a square foot insecurely enough, nevertheless he can use tools, can devise tools. With these the granite mountain melts into light dust before him, he kneads glowing iron as if it were soft paste; seas are his smooth highway, winds and fire his unvarying steeds. Nowhere do you find him without tools he is nothing; with tools he is all." When we look at a massive machine of wondrous power, we seldom reflect that it is a triumph of the tool makers' art, and that the capacity to create massive engines has kept steady pace with the improvements in machine tools. The tendency of many people to forget their benefactors is well illustrated in the works of many writers on engineering subjects. They will fatigue language in descriptions of the products of tools and never say a word about the tools themselves.

Tools have grown from humble beginnings and civilization has grown with their growth. Take for example the hammer, which was doubtless the first of tools. A history of this implement

would embrace the origin and progress of all the useful arts. In tracing the various purposes to which it was applied we should become acquainted with all the important transactions the world has ever seen. How infinitely various we should find the materials, sizes, forms and uses of the hammer. At first a club, then a rude mallet of wood; next the head formed of stone and bound to the handle by sinews of animals; afterward the head formed of metal—copper, and even gold, then steel or iron. It is a pity that ancient historians had so little to say about the growth of the hammer, and of other tools of which it was the parent. Their discourses would make much more interesting and edifying reading than the records of human butcheries which form the mass of ancient history.

The hammer produced modifications of the wedge, the knife, chisel, shears and the axe, and with them the awl or gimlet. The saw and the file represented ages of progress and probably were contemporaries of the first potters' wheel, which was the forerunner of the modern lathe. Applying power to the operating of those tools is of modern enterprise scarcely older than the steam engine. A student of the growth of the mechanic arts is surprised at the small progress which tools had made at the beginning of the nineteenth century. The blacksmith's art had been developed in fabricating armor for war, and a crude boring mill had been invented and improved for boring cannon, but the germs of modern machine tools had not advanced perceptibly since the ancient civilizations had been blotted out by the warfare which they fostered. When James Watt began engine building a few ill-constructed hand lathes, with some drills and crude boring mills constituted the principal furniture of his shop, and we find him writing to a friend that workmanship was improving, for an 18-in. cylinder recently finished was only $\frac{3}{8}$ -in. out of round.

The successful construction of all machinery depends on the perfection of the tools employed; and whoever is a master in the art of tool making possesses the key to the construction of all machines. "The contrivance and construction of tools must therefore ever stand at the head of the industrial arts," said Babbage, of calculating machine fame, at the opening of the 1851 Exhibition. Accepting those ideas as true we must accord high praise to the men whose ingenious labors brought forth modern machine tools.

For years after the steam engine had been applied to driving machinery, the principal machine tool in use was the lathe, manipulated by hand. Its successful operation called for exertion of great physical effort, patient endurance

and accurate skill by which the heaviest work had to be finished. The slide rest introduced a revolution in this tool.

There is great conflict of opinion as to who invented the slide rest. In 1648 Maignan published, at Rome, engravings of two curious lathes for turning the surfaces of metallic mirror for optical purposes, in which the tool is clamped to frames so arranged that when put in motion, it is compelled to move so as to form true hyperbolic, spherical, or plane surfaces according to the adjustment. So also is the screw cutting lathes, fusee-engine and other machines introduced by clock makers. In plates of the French Encyclopedie, published in 1772, there are complete drawings and details of an excellent slide rest, and lathes for amateurs were made according to these designs more than a century ago by Holtzapffel, a German tool maker. English speaking people, however, attribute the invention of the slide rest to Henry Maudsley, an English engineer. Whether he was an original inventor or not cannot now be proved; but it is certain that early in the nineteenth century Maudsley constructed slide rests that rapidly gained popularity in British workshops, where such an attachment had never before been used.

The work of machine tool making was greatly stimulated in Great Britain during the first three decades of last century, through the great increase of manufactures, and by the middle of the century the germs of nearly all modern machine tools had been brought into use. Clock makers had long employed a crude sort of milling machine for cutting the teeth of clocks. This machine was so much improved by Joseph Brahma, the inventor of the hydraulic press, that it gradually came into use in general machine shops. The planing machine came gradually into favor, and no one seems to know who was its inventor any more than they know who first began cutting screw threads by a stock and dies, which was a modern invention. Roberts, of London, made a big planing machine early last century which is now in the South Kensington Museum, but it was by no means the first of its kind.

The early American tool makers displayed much ingenuity in designing special tools such as the lathe, invented by Ely Whitney, for turning gun stocks and other irregular forms, but most of them imitated the tools brought out in England by Maudsley, Whitworth, and others. The home made tools were very crude, stone and wooden beds taking the place of cast iron.

New England shops were better provided with machine tools than any others, yet as late as 1850 crank axles for locomotives were turned on a lathe

that had a wooden bed. The driving wheels were bored on another lathe of similar construction, being fastened to the face plate by means of a wooden chuck with straps and bolts. Before being removed from the place where they were bored, the key ways were spliced with a foot fixed in a bar attached to the foot-stock spindle forced forward by a screw.

The hydrostatic wheel press had not come into use and the wheels were forced on the axle by long bolts and nuts passing through heavy straps outside the wheels. If the force applied was not quite sufficient a few blows from a 50-lb. sledge hammer helped to finish the job. The crank pins were forced into the wheels in a similar manner.

All other mechanical operations were performed with tools that were merely an aid to skilful handicraft.

As the business of tool making became specialized all sorts of elaboration and ornamentation in design were indulged in. It was a curious circumstance that while the early architecture of the United States was severely plain, the designers of such machinery as machine tools and locomotives imitated the worst forms of ancient art for elaborate ornament.

The building of railway machinery gave the first great impetus to machine tool making in the United States. British tools were at first imported and became the patterns from which our machine tools were made; but like the builders of locomotives, American machine tool makers soon displayed original ideas, and they have so perfected their products that they are now regarded as the best machine tool makers in the world, and other countries honor them by imitation.

The existing trend of machine tool making for railroad work is very well described in a paper presented to the Western Railway Club by Mr. James K. Cullen, president of the Niles Tool Works, from which we give the following extracts:

As the efficiency of any machine is determined by the quality and quantity of its output, modified to an extent by the skill of the workman, and the cost of operation, the designer must be familiar with the details of the various lines of manufacture in which it may be employed. He must also possess a theoretical knowledge of the properties of all materials, under all conditions, coupled with a very broad practical experience, before he can expect to solve the innumerable problems which will be presented. When the vast field to be covered is considered, it must be admitted that no ordinary task is imposed upon him, and that his mental equipment must be very complete. His labor

is somewhat lightened on account of the comparatively limited number of methods employed in removing surplus from, or changing the form of, materials of different kinds. Rolling, forging, pressing, planing, turning, milling, grinding, drilling, tapping, punching, shearing and sawing, cover the most important, and all machines for effecting these operations can virtually be classified under one or the other heading.

The existing designs are the result of a gradual evolution, the changes developed being the outcome of the market's demand, combined with the intelligence and versatility of the designer and manufacturer. It is needless to attempt to trace the stages of progression from the ornate productions of twenty-five years ago to the severely plain constructions of to-day.

The most noticeable feature in recent years in machine design is the immense increase in strength and power, and the introduction of cutting steels, having lasting properties under excessive speeds and feeds that appear phenomenal, will make it still more pronounced. Radical innovations are now being made in the most progressive concerns to meet the latest requirements. Fifty to one hundred per cent. increase in power with proportionate additional strength being not unusual to provide for cutting speeds of from forty to seventy-five feet—and the limit not yet in sight.

The very first tool specially designed and built to meet the new conditions was a driving wheel lathe furnished the Altoona shops of the Pennsylvania Railroad Company. Its swing was sufficient to turn tires from 52 in. to 68 in. on the tread at speeds ranging from 10 ft. to 30 ft. per minute. It is driven by a 25 h.p., variable speed motor, connected to gear train by magnetic clutch. The clutch is so constructed that the current can be passed from the end giving the speeds mentioned to the opposite end where a reduction to 4 inches is obtained, this being used to cut out hard spots. The changes are instantaneous and made by the operator simply throwing a switch. A small 3 h.p. motor is attached to the end of the bed for adjusting the right-hand headstock. The gearing are all cut and of gun iron and steel. The main spindle bearings, 13 ins. diameter, 16 ins. long, are of high grade bronze, and the internal sliding spindles, of steel forgings, 45 carbon, 7 ins. in diameter. The power and strength is sufficient to give a pressure of 18,000 lbs. at each tool, which is as much as the steel will stand. Carriages and tool rests are of the most substantial construction and capable of resisting the enormous strains that are imposed upon them. The weight, 80,000

lbs.—about double that of the ordinary lathe of the same swing—indicates its massiveness and rigidity. I regret that I have no record of its output, but as each rest is carrying two cutting tools it may reasonably be presumed that the time of turning is materially reduced. Other machines of a similar character might be described, but this example of what will be needed under the conditions found in the latest practice will serve our present purpose. Designing this class of machinery demands the highest order of engineering ability, as the revolution is complete and knowledge based on existing designs of little or no avail.

Another, perhaps equally important change manifesting itself within the last year or two, is the adoption of motor drive. This was received at first with some degree of doubt, but it has come to stay, and the value of this method is no longer questioned. While there are instances in which the application of motors has been carried to extremes, their use in connection with the larger and most of the medium size tools has proven eminently satisfactory. The extremes referred to are found where the attachment has been made to very small tools, the cost, size and weight of the motors offsetting the economy in their use. The experience of those who have most carefully investigated the subject has demonstrated that direct connection is only serviceable on the larger machines, and that the smallest should be grouped and operated by short lengths of line shaft with motor attached.

For convenience we may divide all machines into two classes, general and special. The former contains those employed in doing the work on a great variety of pieces, and the latter for some specific duty only, or, at the most, for a very limited number of parts.

The trend has been lately toward the specials. This is particularly noticeable in railway machinery; the axle lathe, car-wheel borer, cylinder borer, frog and switch planer, the rod borer, the car-wheel lathe, the frame planer, the frame slotter, and numerous others, having superseded ordinary tools, or very imperfect specials, for the work indicated by their names.

Sharp competition making minimum cost with maximum output of product a necessity, created the call for such tools, and their use has fully demonstrated their efficiency.

One great advantage they possess lies in the requirement of unskilled labor in their operation. Any man entirely lacking in mechanical experience can soon be taught to manipulate them so skilfully as to obtain the best results.

The most tangible economy, however, is in the shortening of the period in which locomotives and cars are out

of service. It requires no detailed statement to impress you with the value of this, long contact with the traffic department having made most of you keenly aware of its importance.

The ancient practice of boring cylinders in lathes, with boring-heads filled with wooden blocks, days being consumed in the work, has given way to simpler methods in cylinder borers, the main opening and the end facing being accomplished simultaneously, with a saving of time of nearly 50 per cent.

The latest double axle lathes have increased the output from four to five axles per day to from fifteen to twenty.

Driving wheels are now finished at the rate of two pair per day, instead of one pair in two days.

Car-wheels, in modern wheel borers, are bored in from seven to ten minutes, two cuts being taken, and steel-tired wheels are turned in car-wheel lathes in two hours per pair.

Frames, in frame slotters, planers and drills, are completed in 20 per cent. of the time formerly required, and in arch-bars, tie-bars, side sheets, crown sheets, flue sheets, and a large variety of boiler and car work, eight to ten holes can now be drilled in the time heretofore needed for one, with arch bar and multiple drills.

Power presses, with pressure gauge and safety attachments, turn out four to five times the work the older machines could, and do it so well that trouble from broken and loose wheels is now rarely encountered.

Bending rolls shape up boiler shells of the heaviest material, at one pass, at a speed of from 10 to 12 ft. per minute.

Hydraulic riveters and flanges, punches with spacing tables, shearing and plate planing tools, have worked a miracle in boiler work.

Three-spindle bolt cutters and seven-spindle tappers have supplanted the single and double spindle tools, and automatic screw machines now turn out more bolts in an hour than a lathe could in a day.

In tools and appliances more especially adapted for repair work, portable cylinders borers, valve-seat planers, crank-pin turners, flue welders and cleaners, stay-bolt cutters, portable crank-pin presses, and numerous devices of similar character, great ingenuity combined with almost perfect adaptability is displayed. The work done by them has effected a saving that in proportion to their cost is far in excess of machines of more pretentious appearance.

Air compressors, making the service of pneumatic hoists, chisels, drills, flue expanders cushion cleaners and paint sprayers possible, are now very generally installed with excellent results, and bulldozers, upsetting machines and steam

hammers are indispensable adjuncts of the modern smith shops.

While so much thought was being expended on the special, the general class has not been neglected, and nothing has been overlooked that would assist in broadening their efficiency along the lines described.

Boring, planing, shaping, slotting, turning, drilling, and other machines, have been virtually redesigned, supplied with automatic stops, wherever possible, and quick adjustments, by hand and power, have replaced older and slower movements.

The range of feeds and speeds has been enlarged until, with the additional power supplied, the only limit is the durability and strength of the cutter.

Convenience in manipulation and minimizing cost of repairs are points that have obtained more than casual investigation. The reduction of frictional losses, a subject overlooked by the copyist, has been diligently studied by the expert designer with the most gratifying returns for his efforts. Correct shape of gear teeth, momentum of pieces running at high velocities, torsional, longitudinal and transverse strains have each been investigated by careful and extended experiment and the information received used to the betterment of previous designs.

Wood-working machinery has kept pace with the iron-working, and this line embraces machines much different from those of even ten years ago. Old patterns have been greatly improved and new ones added. By keeping the automatic feature constantly in mind, mistakes due to carelessness can scarcely occur, the acts of cutting, handling, starting, spacing and aligning being performed almost independently of the operator.

The time has arrived when railroad managers must consider the mechanical department from the same view point as the manufacturer, and treat it accordingly. Heretofore, interest on bonds, roadway and rolling stock improvements took precedence of everything else, and shop equipment was sadly neglected. Requisition after requisition was pigeon-holed, but master mechanics were nevertheless held strictly to account for expense and disastrous delays. A broader and more liberal policy on some of the more progressive lines demonstrated conclusively the advantages accruing from the "weeding out" process, and the others being quick to perceive the valuable results have followed the example set, until all are now imbued with the spirit due to modern methods and ideas.

Before closing, it is proper to pay a just tribute to those who have devoted the best years of their lives to the advancement of mechanical productions.

Master mechanics, not in name only, but by reason of their keen conception of the possibilities and their devotion to the processes needed for the proper development of mechanical questions, have contributed more to the success of the manufacturer, and have done more for the cause of humanity and civilization, than many to whom the meed of praise has been more generously accorded. Too much credit can not be given them for thorough investigations made, the kindly criticism and valuable suggestions offered, making the American machine tool the model for the world.

Theories That Do Not Work Out.

The philosophy of engineering is supposed to point out the way toward logical improvements, and it is right to suppose that valuable inventions have moved in the line of the philosophical sign posts, but a great many of the signs have led into the wilderness.

In the early days of locomotive boiler designing, there was a decided tendency to put a combustion chamber between the fire box and the tubes. Philosophy reasoned that the gases of combustion having insufficient time to combine in the fire box to produce their greatest heat producing compound, the operation could be completed in a combustion chamber, and that space was frequently provided. Hundreds of times the combustion chamber was abolished and tubes put into its place, and the result invariably was that the engines steamed better and burned less coal.

Other philosophical designers held that a combustion chamber was not needed close to the fire box, and that a section of large tubes leading into a combustion chamber was the proper arrangement to promote complete combustion. It was reasoned that the uncombined gases would pass through the large tubes into the combustion chamber and there receive the oxygen necessary to complete combustion, then the perfected gases would pass through tubes of ordinary size to boil the water into steam. Openings to the combustion chamber were provided to admit air, and the argument was made that it was as plain as it is that two and two make four, that a boiler built in this way would be ideal as a steam producer. Many such boilers were made, and, sad to relate, the only way that they could be induced to generate enough steam to get over the road was by closing up the air passage leading into the combustion chamber.

A common arrangement with smoke preventing fire boxes is to put air tubes through the walls of the furnace for the admission of air. It was natural to reason that these air pas-

sages would provide oxygen necessary at the surface of the fire to convert the gases into carbon dioxide, the hottest gas produced from the combination of carbon and oxygen. This combination would produce entirely smokeless gases, and besides being a perfect smoke preventer, the arrangement would prove a valuable means of saving fuel. One of the first patents embracing this idea was secured by Thomas Yarrow in 1857, and he used upright grates behind the tube sheet, through which the air passed on to the surface of the fire. A locomotive with this arrangement was the first one fired by the writer, and he found that the only way to make it steam was to fill up the air passage with clay, and all the enginemen running these smoke-consuming locomotives carried a bucket of clay upon the tender for plastering over the air passage. When the air tubes came into fashion, the same remedy was applied to keep them from chilling the fire; and, strange as it may appear, there was less smoke when the passages were closed than there was when they were open if the fireman exercised ordinary care in doing his work.

Theoretical reasoning would teach and does teach that the distribution of steam in locomotive cylinders that most nearly approaches a hyperbolic expansion curve, as shown by the steam engine indicator diagram, represents the most economical use of the steam for production of work; yet no engineers ever saw a locomotive that produced indicator diagrams, which approached in form diagrams taken from a good automatic engine, that was not wasteful with fuel. How this should be so is exceedingly difficult to understand, but we venture to assert that every engineer who has been accustomed to making tests of locomotives and has no reason to distort facts will agree with this conclusion.

Railroad Disasters and the Chancetaker.

There have lately been several disastrous railway wrecks, and two of them at least stand prominently out as of so serious a kind as not to merit the word "accident," when describing them.

One of these was said to have been caused by an engineer passing a station at night with the order board against him. The facts as reported in the daily press are briefly, that a freight train, whose business was to keep clear of a passenger train going in the opposite direction, was given an order naming a definite meeting point. This order, therefore, gave the freight train the right of track to that point. The passenger train was not given a corre-

sponding order, but the order board was put at "stop" at the station in question, with the intention of halting the passenger train there and so effecting the meeting at a siding a little further on. The train order signal lamp is said to have gone out, in a severe snow storm, and the passenger engineer mistook a switch signal light on a high post for the train order signal at "all right," and the train went on only to collide with the freight train, entailing heavy loss of life.

Any form of train dispatching which, even with the best possible intentions, confers arbitrary rights on an inferior train without previously having notified the superior train moving against it, is not only desperately bad train dispatching, but it is a form of chance taking which has been proved over and over again to be most disastrous. The operator who was charged with the display of the order board, no doubt displayed it in good faith, being cognizant that a siding between his station and the next station was the meeting point. The signal lamp, however, went out, and the operator's failure to observe that fact and to stop the train by other means, shows him to be a chancetaker no less surely than the dispatcher was.

The second wreck, which resulted also in great loss of life, is reported in the press dispatches as being due to an engineer of a passenger train, holding an order to meet a stock train at a certain point, coming to that point, and on finding a train in the siding, continuing his course without surely ascertaining who was there, and acting on the assumption that the train he saw was the train he had orders to meet. This idea was not a mistake by any means, it was an unwarranted assumption, on the part of this passenger engineer, acquiesced in by the fireman, whose business it was to know the contents of all orders. This criminal disregard of the rule requiring absolute certainty as to the identity of the train specified in the order, before proceeding, puts both those men in the class which may be truthfully called "chancetaker," and with the odds of the game against them.

The recklessness of the whole thing is clear when it is remembered that the road beyond the designated meeting point, in which they collided with the stock train, was not theirs, for as they well knew their right to proceed depended absolutely and solely on their meeting, at that point, the particular stock train designated in the order.

This analysis of both these occurrences leads fairly to the conclusion that both were the direct result of taking chances. It is a very common thing on the road, to hear it said, "if a man will not take chances the company does not want him," and also it is frequently

said, "the rules are not made to be observed, but to get the company out of a hole when anything bad happens."

We believe that while these oft-repeated sayings are not absolutely true, yet there must be some fire where there is so much smoke. If these sayings have not a certain amount of truth in them, how does it happen that the primary cause of many a bad railway wreck has been traced home to the unauthorized action of a chancetaker.

The tone of the daily press on these matters shows that the conclusion is beginning to force itself home on the mind of the public that laxity of discipline is the underlying cause of far too large a proportion of the annual crop of railway fatalities. In advocating the compulsory adoption of the block system, the *Philadelphia Press* says: "Congress cannot act too soon in compelling all roads to adopt that system. The terrible slaughter of human life on American railroads—in striking contrast with English roads—is an atrocious disgrace to the nation."

Disasters such as we are contemplating do not usually fall like a "bolt out of the blue" upon blameless railroad operation, nor is the chancetaker developed in a single day. He can flourish only in the congenial atmosphere of lax discipline or when habitually imbued with the get-there-at-any-cost idea. This being the case those on a road who are responsible for lax discipline are themselves chancetakers of an advanced type.

There are unforeseen contingencies which may arise, and there are hidden dangers enough already which follow even the most conscientious railroad man in the discharge of his duty, without anybody adding one illegitimate chance to the sum of those which no human foresight can prevent. The chancetaker increases the odds against successful railroad operation out of all proportion, and his presence on a modern busy, crowded railway is a direct menace to the safety of life and property, and to the good name of the road.

The city authorities in Chicago are not only now guilty of laxity in the enforcement of the city ordinances against theater fires, because of the Iroquois horror. They were as guilty in the days when nothing happened, because they dared to let those concerned come to think that it did not matter. It was the duty of the authorities to see that certain things were done, but they let them go and took chances until the life had been trampled out of hundreds of innocent women and children.

There is something more required to produce the desired result and to get rid of the chancetaker than simply an investigation by railroad officials, into the cause of a railroad disaster,

where the human element had been a prominent feature. This is so because there is the likelihood that a system of operation capable of producing a chancetaker, will not be examined. A fearless, impartial government investigation, conducted by some such agency as the Interstate Commerce Commission, is necessary to get at the real cause, where perhaps official ineptitude may long have been a potent, though silent factor. A searching government inquiry is much less likely to be satisfied, on every occasion, with dragging out from beneath a wrecked engine the dead body of "the only man to blame," than a railway company would be, on whose line wholesale slaughter had occurred.

A government commission would be able to review the record of officials and of employees alike, and might possibly disclose the real chancetaker, hiding in the fancied security of smug officialdom. The man who had been lax in administration in the smooth days when nothing came of it, might be made to stand forth at last. He then would be known and could be punished, as the man who had allowed subordinates to lose their sense of responsibility where the lives of others were at stake, in order that a false and showy record might be made. All this, while the effect on the men, of work badly or recklessly done, and winked at, was steadily piling up like compound interest for the day of final and merciless reckoning.

Book Reviews.

Machine Design, Part I., Fastenings. By William Ledyard Cathcart, adjunct professor of mechanical engineering in Columbia University. Publishers, D. Van Nostrand Company. New York, 1903. Price, \$3.00.

The book with index has 291 pages and the size of the pages is $9 \times 5\frac{3}{4}$ ins. The author tells us in the preface that his chief object is to present in concise form, modern data from the best American practice in this particular branch of machine design, viz.: Fastenings. The work is intended for the student and designer. The subject has been treated theoretically as well as practically, for the science of mathematics plays an important part in work of this kind.

The word Fastenings as used in this book refers to shrinkage and pressure joints, screw fastenings, riveted joints, keyed and pin joints and all the many variations which may be had with each. The stresses which are developed and the requisite sizes of parts are gone into very carefully and thoroughly and numerous useful tables are given. The student is guided all through to safe and efficient design.

Practical Lessons in Electricity. Publishers, The American School of Cor-

respondence at the Armour Institute of Technology, Chicago, Ill. Price, 70 cents.

This book has been compiled from text books used by the American School of Correspondence. It contains Elements of Electricity and The Electric Current by L. K. Sager, B.S., LL.B., formerly assistant examiner United States Patent Office; also, Electric Wiring by H. C. Cushing, Jr., a consulting electrical engineer and a well known writer on electrical subjects. Storage Batteries, by Prof. F. B. Crocker, E.M., Ph.D., who is the head of the Electrical Engineering Department of Columbia University.

The book contains 63 pages and is very neatly printed and well illustrated throughout. The opening words of each paragraph are printed in heavy type which is easily caught by the eye and thus practically gives the subject matter of the paragraph at a glance. At the end of the book are four typical examination papers on Elements of Electricity, The Electric Current, Electric Wiring and Storage Batteries which are intended to give the student an idea of what standard of proficiency is required in the various departments of the subject. The high standing of the authors selected and the price of the book should combine to make it popular with students of electricity.

Free-Hand Lettering. By Victor T. Wilson, M.E. Publishers, John Wiley & Sons. New York, 1903. Price, \$1.00.

This book is a treatise on plain lettering from the practical standpoint for use in engineering schools and colleges and in the drawing office. It is bound in cloth, well illustrated, and contains 95 pages and 13 full-page plates, giving samples of the various forms of letters commonly employed by draughtsmen or sign writers. The author has endeavored to treat the subject so that the student will be lead to do more than merely imitative work. A few hours of study will not develop proficiency; conscientious and patient work is necessary to its achievement. This book should be a great help to those who wish to be able to round off a good tracing, drawing or map, or indeed make designations for drawers, doors, etc., with a clear, elegant and neat form of title.

Arithmetic of Electricity. By T. O'Connor Sloane. Publishers, Norman W. Henley & Company. New York, 1903. Sixteenth edition; revised and enlarged. Price, \$1.00.

This book with an index, contains 162 pages, is a practical treatise on electrical calculations of all kinds reduced to a series of rules all of the simplest form and involving only ordinary arithmetic. Each rule is illustrated by a

practical example. There is an extensive series of tables which takes in all kinds of units of measurement of electrical and mechanical work. Energy and heat. Relations of different systems of all kinds of units, relation of different wire gauges. Electrical properties of wire of different sizes, specific resistances, equivalents, useful factors, etc. This book is useful to those who have to do with the mathematics of electricity and who do not wish to be compelled to use algebra.

Electric Toy Making for Amateurs. By T. O'Connor Sloane. Publishers, Norman W. Henley & Company. New York, 1903. Fifteenth edition; revised and enlarged. Price, \$1.00.

This little book of 183 pages and index and with many illustrations is intended to present to the reader a suggestive line of experimentation and construction and to open a field within which his own ideas can have indefinite scope and extent. The subject of Batteries, Permanent Magnets, Electro Magnets, Electrical Motors, Electric Bells, Miscellaneous Toys, Spark and Induction Coils, Hand Power Dynamos and Miscellaneous Receipts and Formulas, are all included in the ten chapters of the book. The fact that it is now in its fifteenth edition proves its usefulness to those whose tastes run in the direction of electric toy making.

QUESTIONS ANSWERED.

(9) O. A. T., New York, asks:

What is the proper position in a set of blocks and tackle for the block from which the fall rope comes, when you are pulling a derailed or overturned box car toward the track? A.—The block from which the fall rope comes should be attached to the object to be moved. The pulleys in the fixed block at the other end merely change the direction of pull, but the pulleys in the movable block are the "levers" which do the work, and if you have two blocks with an unequal number of pulleys in them, the block having the larger number of pulleys ought to be put next to the object to be moved. See article on page 365 in the August, 1900, issue of RAILWAY AND LOCOMOTIVE ENGINEERING.

(10) Wiper, Toronto, writes:

I have often read in newspapers about a leaf sticking on the headlight of a locomotive and casting a shadow on the track which at night looks like a little animal bounding over the ties ahead of the engine. Will a leaf on the headlight cast such a shadow? A.—It will not. The idea of the animal bounding over the ties always a certain distance from the engine, always there and never run over, works up very well into a more or less readable paragraph

for the non-technical press, but a leaf on the headlight will not cast any appreciable shadow. Many roads use numbers made of sheet iron and carry them across the face of the headlight, yet these figures do not cast a shadow on the track. Rudyard Kipling speaks of the leaf on the headlight in his story, "007," as if it would cast such a shadow but it will not, and you will find this out long before you become an engineer.

(11) A. G. W., Washington, D. C., writes:

Suppose two wheels are keyed on the same shaft. One wheel is 4 ft. diameter, and the other is 2 ft. diameter. These wheels are to run on a track, where one rail is 1 ft. higher than the other so as to keep the shaft perfectly level. Please say if they will follow this track or not. If rails were perfectly level and wheels perfectly round would the small

diameter, and the circle of 62.8 ft. circumference has a diameter of 20 ft., so that it is obvious that the gauge of the track is 10 ft. If you desired the wheels to make more revolutions or to run on larger circles the gauge of the road would have to be made to suit.

(12) S. C. C., West Hartford, Conn., asks:

(1) Is it practical to use the phonograph in the instruction of classes for illustrating lame exhausts, blows, pounds, train air and whistle signals. A.—We think the phonograph might be so used, but it would be necessary to have very good records and a separate record for each kind of defect, and the instructor would have to explain the sounds to the class. (2) Can you tell me the origin or meaning of the names Big Four, Vandalia Line, and Soo Line. A.—Big Four refers to the four

er, and eventually freezing there? A.—There is a remedy for this. A thin coat of pure glycerine put on both sides of the pane will prevent moisture forming there. In time, however, the glycerine collects dust and must be wiped off and fresh glycerine applied. The glycerine being quite transparent the view through the window is not in any way obstructed.

(14) Apprentice, Des Moines, Ia., writes:

In my reading of books I frequently come across the word "pitch" that I am confused about its meaning. I do not mean the stuff taken from pine trees, but mechanical application of the word. Can you help me? A.—There are several ways that the word "pitch" is used. (1) The distance from center to center of any two adjacent teeth of gearing measured on the pitch line



FAST PASSENGER 4-4-2 ENGINE FOR THE "BANNER ROUTE."

wheel have to slip to keep up with the larger one. A.—Wheels of the sizes you mention and mounted as you describe would not run on a straight track at all. In one revolution the larger wheel would have moved over 125.6 ft. and the smaller one over 62.8 ft. of track. Mere slip in the smaller wheel would not keep the larger one on its rail, unless the flange of the larger wheel was on the outside of the rail, and even then the tendency to mount would be very great. These wheels would work in perfect harmony on a circular track, and after you had decided on the number of revolutions you desired them to make in going round you would thereby practically determine the gauge of the track. For instance, suppose you arranged that ten revolutions would complete the circle. The larger wheel would have gone over 125.6 ft. and the smaller one over 62.8 ft. of track. A circle with a circumference of 125.6 ft. measures 40 ft. in

large cities which are included in the incorporated name of the road, viz.: Cleveland, Cincinnati, Chicago & St. Louis. The Vandalia Line is called after the town of Vandalia in Illinois, through which the road runs. The Soo Line is called so on account of the popular pronunciation of the French word Sault in the name of the road, viz.: Minneapolis, St. Paul & Sault Ste. Marie. (3) What is the usual system of numbering cars and engines. A.—Cars and engines are generally numbered in rotation, for instance, engine 400 would ordinarily be the 400th engine owned by the company, unless some number had been skipped so as to make some particular class begin with an even number.

(13) R. P. C., Winnipeg, Manitoba, asks:

Is there any method which will prevent moisture forming on the cab windows of a locomotive in cold weath-

which gives the pitch of gearing. (2) The distance measured on a line parallel to the axis between two threads of a screw, which is the pitch of the screw. (3) The distance between centers of holes or rivets or stay bolts. (4) The pitch of a roof is the inclination of the slope of the sides. (5) The pitch of a saw is the slope of the teeth.

Fast Passenger Engine for the Wabash.

The Wabash Railroad have lately received from the Brooks shops of the American Locomotive Company some fast passenger 4-4-2 engines. They are simple engines with piston valves. The cylinders are 21x26 ins. and the driving wheels are 83 ins. in diameter. The driving wheel centers are cast steel and have substantial spokes. The connecting and side rods are both fluted and the big end connection even suggests marine practice. The motion of this en-

gine is direct. The transmission bar passes over the leading driving axle, and though it is attached to the lower end of a rocker, the illustration shows that the arms of these rockers both hang down.

The main reservoir is carried under the running board, a section of which is raised in order to admit it being placed above the drivers. The crosshead has the top guide bar cut with an overhang and the crosshead is lipped up into this. The object of this arrangement is to avoid a vertical opening between guide and crosshead down which sand and grit may work. The tumbling shaft is a steel casting and the reach rod is made of pipe which screws into jointed ends. A reach rod of this form gives less vibration than a flat rod does, and is light as well as strong.

The boiler is a radial stayed wagon top, and the sloping sheet is the first course. This gives plenty of steam room in the boiler. The diameter of the first course at the smoke box end is $64\frac{1}{4}$ ins. The heating surface amounts to 2,676 sq. ft. in all, 2,499 sq. ft. being in the flues and 177, in the fire box. The tubes are 294 in number and are 16 ft. 4 ins. long.

Some of the principal dimensions of these engines are appended for reference. Mr. J. B. Barnes is superintendent of motive power and machinery of the Wabash.

General Dimensions—Weight in working order, 180,700 lbs.; weight on drivers, 96,700 lbs.; weight engine and tender in working order, 310,700 lbs.; wheel base, driving, 7 ft. 6 ins.; wheel base, total, 30 ft. $11\frac{1}{2}$ ins.; wheel base, total, engine and tender, 86 ft.

Valves—Greatest travel of slide valves, $5\frac{1}{8}$ ins.; outside lap of slide valves, $1\frac{1}{4}$ in.; lead of valves in full gear, $\frac{1}{8}$ in.

Wheels, etc.—Dia. and length of driving journals, $9\frac{1}{2}$ in. dia. x 12 ins.; dia. and length of main crank pin journals, $6\frac{1}{2}$ ins. dia. x $6\frac{1}{2}$ ins.; dia. and length of side rod crank pin journals, $7\frac{1}{4}$ ins. dia. x $4\frac{1}{2}$ ins.

Boiler—Working pressure, 200 lbs.; thickness of plates in barrel and outside of fire box, $\frac{3}{16}$, $\frac{9}{16}$, $\frac{1}{2}$, $\frac{1}{2}$ in.; fire box, length, 102 ins.; fire box, width, 63 ins.; fire box, depth, front, $75\frac{1}{2}$ ins.; back, $65\frac{1}{2}$ ins.; fire box plates, thickness, sides, $\frac{3}{8}$; back, $\frac{3}{8}$; crown, $\frac{3}{8}$; tube sheet, $\frac{1}{2}$ in.; fire box, water space, front, 5 ins.; sides, $4\frac{1}{2}$ ins.; back, $4\frac{1}{2}$ ins.; heating surface, tubes, 2,499 sq. ft.; heating surface, fire box, 177 sq. ft.; heating surface, total, 2,676 sq. ft.; grate furnace, 43.7 sq. ft.; smoke stack, top above rail, 15 ft. 3 ins.

Tender—Weight, empty, 55,460 lbs.; water capacity, 6,000 U.S. gal.; coal capacity, 12 tons.

Watt made his first model of a condensing engine out of an old anatomist syringe used to inject the arteries previous to dissection.

The great inventor is one who has walked forth upon the industrial world, not from universities, but from workshops; not clad in silks and decked with honors, but clad with fustian and grimed with soot and oil.

Signals and Signaling.

BY GEORGE S. HODGINS.

(Continued from page 7.)

THE TRAIN ORDER SIGNAL.

The train order signal is generally a two position signal, and is defined in the report of the committee on signaling and interlocking, which was presented to the American Railway Engineering and Maintenance of Way

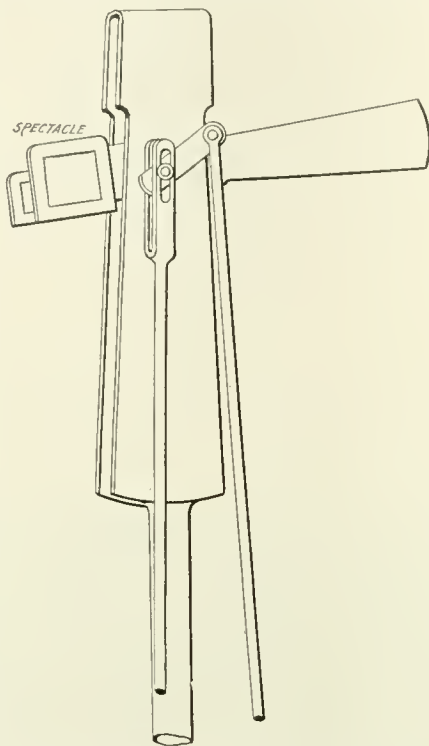

BLACK AUTOMATIC SIGNAL AT "DANGER."
(Described on page 9, January issue.)

Association, in Chicago, in March, 1903. The recommended definition of the train order signal reads: "A signal fixed or otherwise of two indications, which, in the stop position, informs the enginemen and conductor that they are to receive orders at the telegraph office, and in the clear position announces that there are no orders for them."

This definition includes a recognition of the use of flags as train order signals, and, indeed, the report definitely mentions them as legitimate signals for such a purpose. The tendency of modern practice is to standardize and make uniform signal appliances and methods, and though the flags hung out beside the telegraph operator's window may give a satisfactory "stop" or "proceed" signal at a station, the practise is not likely to grow in favor.

The early form of train order signal was that of a switch target, with switch lamp for night, hanging from or standing on a bracket close to the telegraph office window. In the "stop" position it indicated that orders were held at that office for some train, and all trains moving in either direction

were compelled to halt, and ascertain if the display of the train order signal was intended for them or not. In the "proceed" position, it indicated that no orders for trains were held at the office.

The use of this signal which, when displayed, stopped trains for which there were no orders, brought into use what was called the "train clearance" order. This order was issued to a train which had been stopped by the display of the "order board," as it is sometimes called, and the clearance order stated to the train crew in question that the train order signal here displayed was for such and such a train, and that it did not affect the train to which the train clearance order was issued.

With the advance of block signaling methods the use of semaphores has very largely increased and has correspondingly displaced the switch target and lamp as a train order signal. A form of train order signal very much used at the present time is an upright post usually placed in front of the station, and which post carries two semaphore arms, which latter stand out on each side of the post, the display side of each being painted red with a white band near end, while the backs of the arms are painted white with a black band near the ends. One lamp placed on top of the post does duty for both arms. This form of signal is used on both single and double track roads, and is generally and preferably a two-indication signal.

The advantage in the use of the two semaphore arms is that only trains moving in one direction need be stopped when one of the arms is displayed. A form of good practice, however, with regard to train order signals is to op-

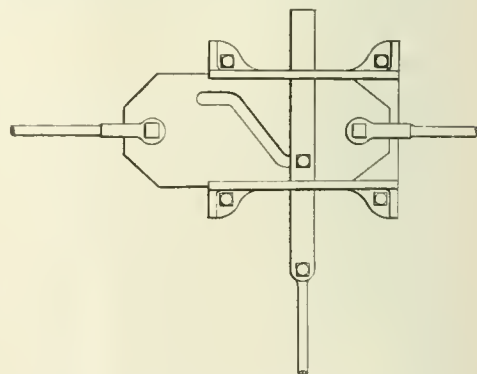

MOTION PLATE FOR "BLACK" AUTOMATIC SIGNAL.
(Explained on page 9.)

erate them on the "normal stop" principle; that is, the signals are always displayed in the "stop" position, their heavy spectacle castings constantly keeping the arms horizontal unless purposely pulled to the "proceed" position by the operator, on the approach of a train. In this way a

train nearing a station will be forced to stop and make inquiries concerning orders unless definitely allowed to proceed, by the lowering of the semaphore arm.

At first sight this may not appear as much of an improvement on the switch target and lamp which, when displayed, stopped all trains, but on more careful examination the method of which we speak will be seen to possess ad-

difficulty in obtaining the order or an explanation as soon as they bring him back to consciousness.

The standard code, however, leaves the use of the "normal stop" or the "normal clear" systems optional, with reference to train order signals.

A form of train order signal which is recommended in the report already referred to, when placed about the middle of station platform is a double sema-

tion is that of economy. If train order signals and block signal semaphores on a road all use the same form of spectacle casting, the advantages of such uniformity and interchangeability are self evident.

When the three position spectacle is used it is very easy to maintain the two position practice by placing two red glasses in the spectacle spaces for the horizontal and the 45° positions as shown in the illustration, and the green in the vertical position space, thus making use of the continuous light principle.

It may be asked what use would likely be made of the train order signal on a double or a four track road, fully equipped with automatic block signals. The double track obviates the necessity of making meeting points, and the block system keeps trains apart, which are moving in the same direction. It might, however be necessary to issue instructions regarding repairs to a bridge or culvert, or to give notice of a washout or of a wreck, or conditions might arise which would require the use of one of the tracks for a reverse movement of traffic from that generally passing over it, or to pick up or deliver some material or perform some important service, or to look out for some unusual condition, the knowledge of which is essential to expeditious and safe train movement.

Another very good form of the train order signal for a double track road is

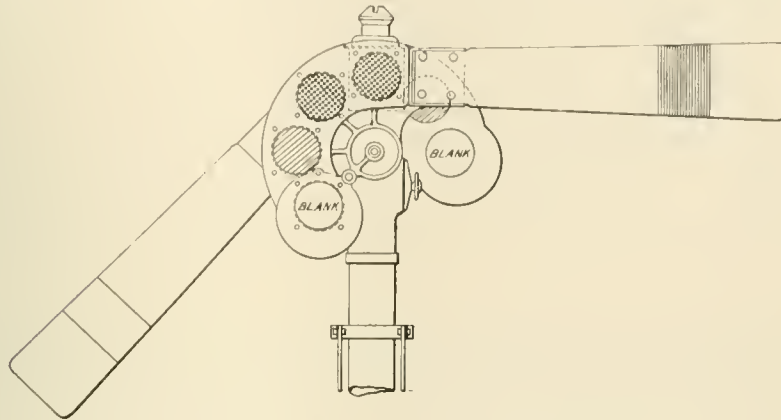

TRAIN ORDER SIGNAL WITH TWIN SEMAPHORE ARMS ON ONE POST, CONTINUOUS LIGHT PRINCIPLE.

vantages. The "normal stop" train order signal, when properly operated, practically informs the men on the engine that the approach of their train is recognized, and if there are no orders for them the signal arm is lowered. If the "normal stop" system be used the standard code rule requires that when an order is received for any train, that all trains going in the same direction must stop and get a clearance order until the train order has actually been delivered to the train concerned. Time lost in an unnecessary stop caused by an inattentive operator can easily be accounted for and discipline can then be maintained. The "normal stop" system, as applied to train order signals, has another safety feature in connection with it. Operators have been known to have received orders and to have failed in delivering them owing, perhaps, to sheer forgetfulness, or to being asleep when the train concerned, passed. The "normal stop" system reduces the chances of forgetfulness, because it forces an operator to go through a definite purposive act on the approach of a train, which is equivalent to his saying in so many words that he has no orders for that train. If he has orders, memory is likely to assert itself while he is in the very act of moving forward to grasp the lever, and if he is also compelled to deliver a clearance, placed in a hoop and caught by a man on the moving train, the chance of error is still further reduced. In the case of an operator overcome with sleep, the crew of the halted train will have no

phore on a single post with a lamp on the top of the post, the arms on each side swinging through 90° and using the three position spectacle. This is recommended because it may possibly be necessary under certain conditions to use the 45° or "caution" position with the



TYPICAL SIGNAL BRIDGE, BLOCK SYSTEM.

train order signal, though the horizontal and the vertical positions are the ones most generally used. The report points out that it might become advisable to give to a train such "caution" information as this: "No orders for you here, but look for train ahead before you get to the next telegraph station."

Another reason for this recommenda-

two single semaphores placed each about 150 feet beyond the ends of the station platform. In this way a passenger train may draw in, halt and discharge passengers and baggage without the engine having passed the "order board" which governs its movement. The signal is therefore in front of enginemen and conductor, when the train is standing at

a station, and the conductor's statement concerning the position of the signal as he comes from the telegraph office can be verified by inspection by the men on the engine. For a four track road, two bracket posts in similar positions, one at each end of the platform, bearing each two semaphores, gives the same style of train order signal. Where such separate signals are used, the report to which we have before referred suggests the use of standard spectacle castings so that economy in the amount of stock carried may be had.

described is operated on the "normal clear" principle, but with the additional precaution that its movement operates the "distant" arm on the block signal post, governing the entrance to the block in which the station is situated. When this train order signal is at "stop" at any station, a "caution" indication is thus given to an approaching train, at a distance of from half a mile to one mile before the station is reached. When the train order signal is at "proceed" this "distant" signal moves as other similar signals move when operated in the regular block signal system. This arrangement still preserves the function of the "distant" block signal, which says in effect to an oncoming train, "The next signal is against you; prepare to stop now."

(To be Continued.)

Size of Nozzle Key to Free Steaming.

In a paper which was presented to the Central Railroad Club by Professor Goss, part of which is published on another page, the author argues that a form of smoke box and stack arrangement can be designed which will suit all kinds of engine, every species of coal and all the varying conditions of engine operating encountered on all the railroads on this continent. The claim is made that when an engine is not steaming freely all the change necessary to make it produce all the steam necessary will be to contract the nozzle to the required extent. If this condition of affairs ever comes about it will introduce a premature millenium into railroad service, but no practical indications that such a happy state of affairs is coming have yet appeared. "Close the nozzles," is an old-time remedy for poor steaming that every round-house foreman has been fatigued hearing. In probably the majority of cases where this remedy was demanded the engine worked worse than it did before the change was made.

An indication that business is improving from the temporary depression of November last is seen in complaints about growing scarcity of cars. The Lake Shore reports it is 500 cars short of orders from the grain shippers, and that as many more could be used for general loading at Chicago. Pennsylvania could use 1,200 cars more, and among the eight other railroads operating eastward the car shortage is easily lifted to about 4,000 cars. Westbound traffic is arriving at Chicago in such large colume that the situation is on the verge of congestion. Every class of tonnage is said to be running ahead of last year save that of iron and steel. Officers estimate that the eastbound movement

of general tonnage for the year will show an increase of approximately 700,000 tons.

My Brother Hen.

Nigh Forty years on his Engine's right
Has he watched the thrill of the Plunging fight.
And he's held in the hollow of his good right hand
'Nough Souls to populate the Promised Land;
And he never flinched—for he had the Sand—
Had my Brother Hen.

Times Oft has he thrown her open wide
In following orders to make the side.
A command to him was as good as done,
For his life was the Road's till the end of the run;
But at home with the Kids, he had his fun—
Did my Brother Hen.

Any time the Old Man—that's the Pres. of the line—
Took a few of his friends up the road for a time,
You can bet that my brother was booked for that day;
Yet I guess He'd stayed home, if he'd had his say.
Love has the call, but duty the sway—
With my Brother Hen.

His Engine's alive, sympathetic—just his Twin—
Short of soul, well she knows, her driver's a Kin.
He's always alert, and with unerring rein
Guides the Great Iron Horse, who responds with a brain;
It's the Coal and Gray Matter that Bosses the train—
Says my Brother Hen.

I suppose when the Chief Engineer up on high
Gets word that Hen Adams is enroute thro' the Sky,
He'd give orders for room to be made near the Throne,
Saying here comes a Star that below alway shone,
Just give him the best for He's one of my own—
That, my Brother Hen.

F. B. ADAMS.

The band saw looks to be a humble member of the family of tools, but the ancients considered it of so much importance that the inventor of the saw was given a place among the gods in the Greek mythology.

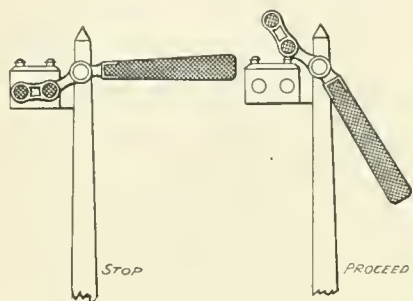

TRAIN ORDER SIGNAL, C. R. R. OF N. J.

On the Central Railroad of New Jersey, which road uses separate semaphores placed beyond the ends of the station platforms, a still further precaution is taken for the purpose of securing the safety of train movement. The train order lamp case contains two separate signal lamps, and when the "order board" is displayed at night two red lights, side by side, are shown. This practice has the advantage of making the night train order signal quite dis-



SIGNAL BRIDGES.

tinct in character and easily distinguished from switch, block, interlocking or other signal lights. In case one light should go out there will yet remain one red light which insures a stop. In case both lights should go out, the train order signal, whether in the "stop" or the "proceed" position becomes at once "conspicuous by its absence," to use a familiar phrase, and it is difficult to understand how its omission could fail to be noticed by enginemen. A suitable double light spectacle is, of course, used with this form of signal.

This twin light train order signal here

Pennsylvania 4-4-2 Engine Built at Altoona.

Through the courtesy of Mr. Theodore N. Ely, chief of motive power of the Pennsylvania system, we have received a photograph and some data about an E.3.a class simple passenger engine of the 4-4-2 type lately built at the Altoona shops of the company.

The cylinders are 22x26 ins. and have 80 in. driving wheels. The weight of this machine in working order is 183,130 lbs. The adhesive weight amounts to 118,350 lbs. while the carrying wheels at the rear bear about 31,130 lbs. and the engine truck 33,650 lbs. The driving and carrying wheels are all equalized. The driving springs being carried upon saddles on top of the boxes in the usual way. The rear spring of the engine is placed behind the 50 in. carrying wheel and an axle

The fire box has 166 sq. ft. of heating surface which added to that of the flues, gives a total heating surface of 2,640 sq. ft. The steam pressure carried is 205 lbs.

Among the ratios worked out by the builders for this engine may be mentioned the ratio of heating surface to grate area which is 47.56. This means that for every square foot of grate area there are over 47 sq. ft. of heating surface provided. The ratio of external flue heating surface to fire box heating surface is 14.9. That means that for every square foot of fire box heating surface there are nearly 15 sq. ft. of heating surface in the flues. The calculated tractive power of this engine, assuming the mean effective pressure in the cylinders to be $\frac{1}{2}$ of the boiler pressure, is 25,800 lbs. and the ratio of calculated tractive power to

this is the observation compartment fitted with 16 big chairs. It also has a library and writing room. There are also six smaller compartments, each with a different color scheme. A number of other cars of similar luxury in appointment are to replace the present equipment on the Pennsylvania limited.

Blows and Pounds in Simple Locomotives.

POUNDS.

Some very annoying pounds are often encountered in the simple locomotive type that at times are hard to locate by the novice and old enginemen. Some require immediate attention to prevent damage to machinery and rolling stock. The remedy is often very simple when properly located. While the subject may be old to some, still the host of men



ATLANTIC TYPE ENGINE FOR THE PENNSYLVANIA, BUILT AT THE ALTOONA SHOPS.

box equalizer rests upon the carrying wheels' journal boxes. Between this and the rear driver the equalization is brought about by a series of three, pivoted equalizers and hangers. The half-tone, however, shows a modification of this arrangement whereby the rear spring is placed upon the lower frame bar and is equalized both ways to the rear driver and the carrying wheel. The main valves are of the balanced D-slide type having 7 in. travel and $1\frac{1}{2}$ in. lap. The steam ports are $1\frac{1}{2}$ x20 ins. and the exhaust ports are 3x20 ins.

The boiler has a Belpaire wide fire box and the minimum internal diameter of the boiler 65 $\frac{5}{8}$ ins. There are 315 tubes, measuring each 180 ins. in length which gives a heating surface of 2,474 sq. ft. The fire box is 72x111 ins. with a grate area of 55 $\frac{1}{2}$ sq. ft.

adhesive weight is as 1 is to 4.5. The driving wheel base is 7 ft. 5 ins. The total wheel base of the engine is 30 ft. 9 $\frac{1}{2}$ ins., while the wheel base of the engine and tender is 60 ft. 1 $\frac{1}{8}$ ins. The whole design is well proportioned and the engine presents a neat and trim appearance. The absence of piping and other attachments along the boiler is very marked and contributes largely to the pleasing effect produced.

The Kenilworth, a compartment observation car recently put on one of the Pennsylvania Railroad limited trains, is said to be the finest car for public use ever put on a railroad. The exterior is of Tuscan red, the standard color of the Pennsylvania road. The trimmings are in gold. At the rear end of the car is a large observation platform and just off

who are preparing to supplant the present generation of locomotive engineers are anxious to succeed in their chosen calling.

We will begin our subject with a loose follower bolt. Old engineers have been known to allow the piston to destroy the cylinder head through their inability to locate the pound. A loose follower bolt can only give trouble at one end of cylinder, the forward end, and then only when the piston reaches the forward end of stroke. The first warning comes with the closing of the throttle when the engine is drifting. As soon as the throttle is opened and the lever cut back toward the center pounding ceases as the steam forming a cushion takes up the lost motion in the rods. No time should be lost in coming to a stop. Remove the cylinder head and if the bolt can not be

tightened remove it entirely. This same pound may also occur with defective rod work, but will manifest itself as soon as the engine leaves the round-house. If the rod has been made too long the pound will be on the forward head, and if too short on the back head. A loose piston head on the rod will pound the forward head and generally takes place where steam is exerted against the piston and the first indication will be a heavy knock when the engine is passing the back dead center and a click in passing the forward center. If the piston is secured to the rod with a nut that can not be lightened or has a key to secure it, remove it from the cylinder entirely, as safe repairs cannot be made.

A loose piston rod in crosshead will pound the forward head. Stop at once and if it is found that the crosshead

BLOWS.

These affect the steaming qualities of the engine and are often harder to locate than the pounds of which we treated in a previous subject.

A valve blow is often confounded with a cylinder packing blow, especially with the balanced type or one with supplementary ports. The most prolific cause is improper adjustment of the valve table or the proper dimensions of the valve. The distance between the table and valve of the Richardson balanced valve should never be over $\frac{1}{8}$ in. If this distance is exceeded broken balance strip springs are usually the case, particularly where an inferior spring is used. The balance strip otherwise held up by the spring settles down in the valve groove, steam passes over it and out of the small hole in top of valve to the exhaust. This hole is essential under normal con-

ditions, as it permits any steam that may escape to pass out of it. Without this hole the valve would lift off of its seat. With any of the strips down the lever handles with a hard jerky motion when the valve makes the return stroke on the defective side. A valve blow from a cut valve seat and valve will give a wheezing, intermittent sound, while the blow from a valve strip stuck down or broken gives off a clattering, vibratory sound.

A leaky or cut piston valve, in addition to a blow, will give a much heavier exhaust on the side the trouble is on and make the engine sound out of square. When a valve blows only when lever is down in either the forward or back notch, and ceases as soon as the lever is cut back toward the center the valve overreaches the valve seat and is often due to a bent or loose tumbling shaft arm. In testing for cylinder packing it has been customary to test one side at a time. Both sides can be just as easily tested at the same time by placing the main pin on the right side on the forward top eighth. This brings the left

main pin to the back top eighth so that both valves admit steam to their respective cylinders. Admitting steam to the cylinders with the engine in this position and cylinder cocks open should steam escape from all four cylinder cocks it is conclusive evidence that the cylinder packing of both pistons are worn or broken and need prompt attention. In this case the packing will blow when engine passes either center. Should the blow occur when passing only one center it's an indication of a hole in the follower plate or spider or a broken follower. In this it differs from a valve overreaching in that the blow takes place at all points of cut off.

Loose exhaust stand, tip or leaky steam pipes are always detected by their action on the fire. Instead of a bright, white fire, it is always of a dull red, with a tendency to drive the heat out of

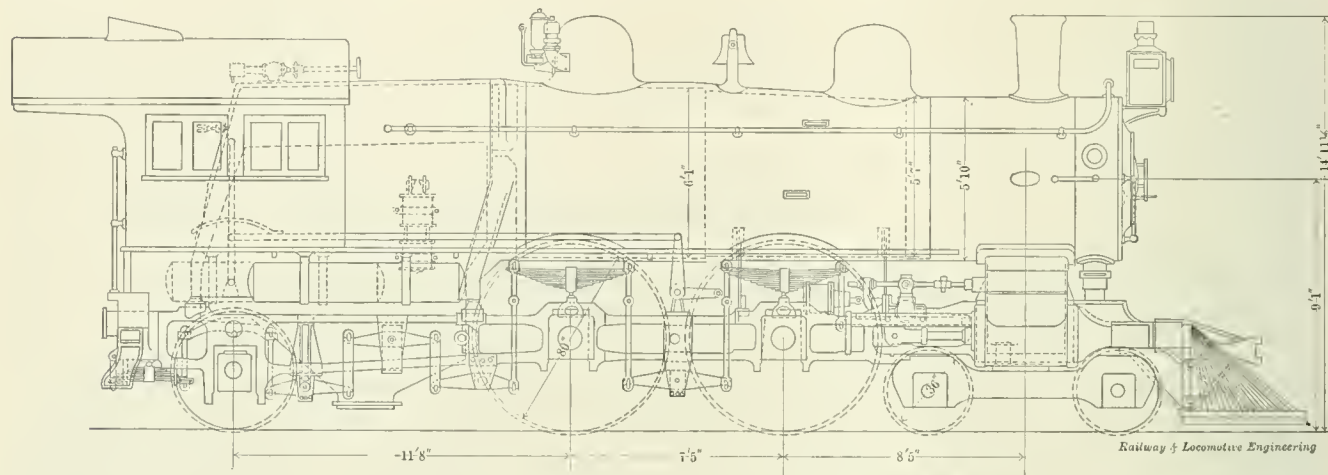

SIDE ELEVATION OF PENNSYLVANIA 4-4-2 PASSENGER ENGINE.

key is not the proper taper or the key is bent, remove the piston rod from cylinder.

Pounds in rods and driving boxes are found by placing the engine on the top quarter and blocking the wheels, admit just enough steam to produce a movement of the boxes and rods when the lever is moved backwards and forwards. If it is found in the rods it may be due to a loose key or a badly worn brass. If the pound is in the forward end of main rod, hot main pins are always the result.

Pounds in boxes may be attributed to worn brasses, improperly fitted shoes and wedges, or improper adjustment of wedges by the engineman or inspector. The most pernicious practice is that of some enginemen, who finding an opportunity to set up a few wedges on a side track do so without giving the others the proper attention. The result is the drivers are thrown out of tram, tire flanges are cut, driving box brasses are pounded out of true, and the engine gives continual trouble until she enters the shop for general repairs.

As it permits any steam that may escape to pass out of it. Without this hole the valve would lift off of its seat. With any of the strips down the lever handles with a hard jerky motion when the valve makes the return stroke on the defective side. A valve blow from a cut valve seat and valve will give a wheezing, intermittent sound, while the blow from a valve strip stuck down or broken gives off a clattering, vibratory sound.

A leaky or cut piston valve, in addition to a blow, will give a much heavier exhaust on the side the trouble is on and make the engine sound out of square. When a valve blows only when lever is down in either the forward or back notch, and ceases as soon as the lever is cut back toward the center the valve overreaches the valve seat and is often due to a bent or loose tumbling shaft arm. In testing for cylinder packing it has been customary to test one side at a time. Both sides can be just as easily tested at the same time by placing the main pin on the right side on the forward top eighth. This brings the left

the fire door with each exhaust of the engine. Leaky steam pipes or exhaust stand are mostly due from loose saddle bolts, causing the cylinder saddles to work.

Big Output of Locomotives.

The Baldwin Locomotive works closed the year 1903 with a record of 2,022 completed locomotives turned out. This output surpasses any previous record in the history of this great industrial establishment, exceeding its previous best record of 1,533 locomotives in 1902 by fully $33\frac{1}{3}$ per cent. In addition to the 2,022 completed locomotives there were turned out of the works during the year duplicate or repair parts equivalent to about 313 complete locomotives. Of the completed locomotives 1,966 were for service in the United States and 56 for service in the following countries: China, Cuba, Japan, Yucatan, Hawaii, British Columbia, Peru, Costa Rica, Mexico, Newfoundland, England, Brazil, Nicaragua and Porto Rico. Compound cylinders were applied to 300 locomo-

tives, while 85 were operated by electricity and six by air. The value of this large output approximated about \$28,000,000 and represented the united efforts of a weekly average of 14,720 men, working 10 hours per day, some on day turn and some on night turn. Regardless of what the new year may have in store, the firm has at present on hand orders sufficient to keep the big plant busy for the next three months.

A city which can point to the fact that it averages over six locomotives daily

The car is intended for the carriage of grain and is a good example of the carbuilder's art. The fact that the car has continuous steel sills permits the use of draw gear placed on a level with the center line of the center sills. This brings the stresses due to pushing and pulling where they should be, and where they can be taken up with the least chance of doing harm to the car.

The capacity of the car is stencilled on the side at the brake-mast end, and is in larger figures even than the



BOX CAR WITH STEEL FRAME, 100,000 POUNDS CAPACITY.

is naturally pictured in the mind of the stranger as a great manufacturing place, and a city of mechanical skill.

Facts such as this deserve to be scattered broadcast. It is such statements that give to the world the true idea of Philadelphia's prominence as a great manufacturing city, and some idea of the great plants which prevail here. It explains why Philadelphia is the city of industry, of progress and of homes.

Box Car With Steel Underframe.

The Middletown Car Works, of Middletown, Pa., have recently turned out some cars for the Illinois River Packet Company. The cars here illustrated are wooden box cars with steel underframe. The form of construction has been patented by Mr. George D. King, vice-president and general manager of the company.

The car is 40 ft. long inside, and its light weight amounts to 48,000 lbs. The center sills are made of 15-in. channels extending from one end of the car to the other, and this has been done without in any way sacrificing the strength of the truck bolsters. The floor and roof are at the level recommended by the last M. C. B. committee, which reported on standard box-car design.

The truck bolster is extremely simple and at the same time stiff enough for the service required. In this design effort has been made to keep out special and complicated features which are costly to repair. The side and end frames are very heavy and the post and brace pockets have been designed on the lines recommended by the M. C. B. box-car committee.

weight. The stencilling of capacity on the side of a car is in accordance with the M. C. B. rules, but we have known some private lines who do not put it

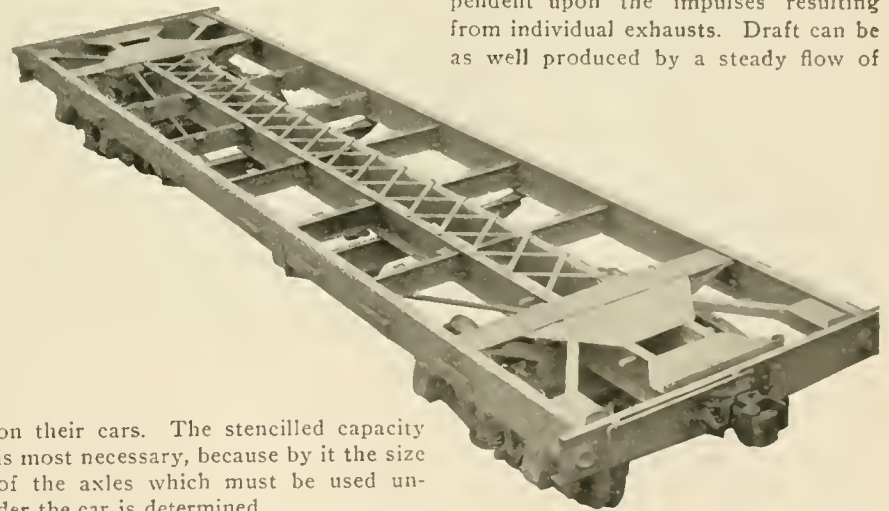

MIDDLETOWN CAR CO.'S STEEL UNDERFRAME FOR BOX CAR.

on their cars. The stencilled capacity is most necessary, because by it the size of the axles which must be used under the car is determined.

For cooling rod pins, as curing hot boxes, there is nothing equal to Dixon's graphite.

A patent was granted to Cornelius Vanderbilt of New York last month to protect a self-dumping railroad car, which he has invented. Mr. Vanderbilt is not a new inventor on the patent office records by any means. His inventions cover a wide range of mechanical subjects, although they all relate to railroad matters in some way or form. The latest creation of his busy mind is a car which dumps itself with the least possible exertion from the people managing the dumping.

Locomotive Front Ends.

At the November meeting of the Central Railway Club, Professor Goss presented a paper on Recent Progress in the Design of Locomotive Front Ends, which brought out a discussion that illustrates the existing diversity of practice and proves how hopeless it is to offer the results of laboratory tests as a guide for the men in charge of locomotives. The paper discussed the action of the exhaust jet and the combinations that are most likely to produce the most satisfactory results in the generation of steam by the action of draft. It contained nothing new to add to the discoveries made by committees of the Master Mechanics' Association and of other investigators whose conclusions are familiar to all readers of the literature of the subject. The summary of the paper reads:

1.—The jet acts upon the smoke box gases in two ways; first, by frictional contact, it induces motion in them, and, second, it enfolds and entrains them.

2.—The action of the jet upon the smoke-box gases is to draw them to itself so that the flow within the front end is everywhere toward the jet.

3.—The action of the jet is not dependent upon the impulses resulting from individual exhausts. Draft can be as well produced by a steady flow of

steam as by the intermittent action of the exhaust.

4.—Drafting resulting from the action of the jet is nearly proportional to the weight of steam exhausted per unit of time. It does not depend upon the speed of the engine nor the cut-off of steam from the cylinders, except in so far as these affect the weight of steam exhausted.

5.—The form of the jet is influenced by the dimensions of the channels through which it is made to pass. Under ordinary conditions, it does not fill the stack until near its top. If the di-

diameter of the stack is changed, that of the jet will also change.

President West: Two or three years ago we had engines of a certain build that never steamed freely. They had a single exhaust. The traveling engineer of the Erie told me one day that they were getting wonderful results from a double exhaust. That arrangement was applied to our engines with wonderfully good results.

Mr. Mellon said that the Delaware, Lackawanna & Western received some passenger engines that did not steam well. They had a single nozzle which was changed for double nozzles, the choke stack was changed to a straight stack, and the engines were greatly improved.

President West made reference to engines that were running upon the Beech Creek Railroad with a hole in

perfectly satisfactory, whereas, with low nozzles they would not steam at all.

Mr. MacBeth said that he had never found an engine that steamed freely that did not throw fire, and that is the only way they can clean the front end.

Mr. Tunkey said that all the passenger engines on the Lake Shore had self-cleaning front ends, and insisted that they did not throw fire.

Mr. Meadows said that the latest Michigan Central engines have front end 72 inches diameter. They use a modified form of the Master Mechanics' front end, and with a double draft pipe and single nozzle. The front ends are absolutely clean. They do not throw fire.

President West's experience was that engines that catch the sparks in the smoke box are those that throw fire.

pressure, with the least possible back pressure upon the engine. Of course, if the grate is close, there must be a greater difference of pressure to bring air through, and to maintain this greater difference of pressure the front end must do more work. To make the front end do more work it should not be necessary to change its design. The only thing that should be necessary is to reduce the diameter of the exhaust tip. When other things are right, the tip is the one element by the adjustment of which the varying conditions of fuel and of grate area are to be met. If to burn hard coal a stronger draft is required than for soft coal, the one change which should be made in the ideal front end when the locomotive goes from soft to hard coal is a slight reduction in the diameter of the tip. When the design of the front end is perfect, the question of steaming becomes merely a matter of the diameter of the nozzle.

The statement in the paper that the efficiency is not dependent upon the condition of running means that if a front-end arrangement is efficient under one condition of running, it will be found to be efficient under all conditions of running. In other words, when by repeated trials a front end has been found which gives good results when the engine is run under a certain cut off and at a certain speed the question at once arises as to whether the arrangement in question will prove satisfactory at other cut offs and at other speeds. The paper answers this question in the affirmative. It states that an arrangement which works evenly for one speed and one condition of running will work with relatively the same efficiency under all conditions of running.

The question has been raised as to whether the cylinder is to be regarded as a factor in the design of the front end. I do not think that it is. We have a sufficient number of variables already and if we can keep the cylinder out we ought to do it. The demand for steam is upon the boiler and that demand is met by the furnace in response to a condition of draft that is brought about by a jet of steam which comes from the boiler.

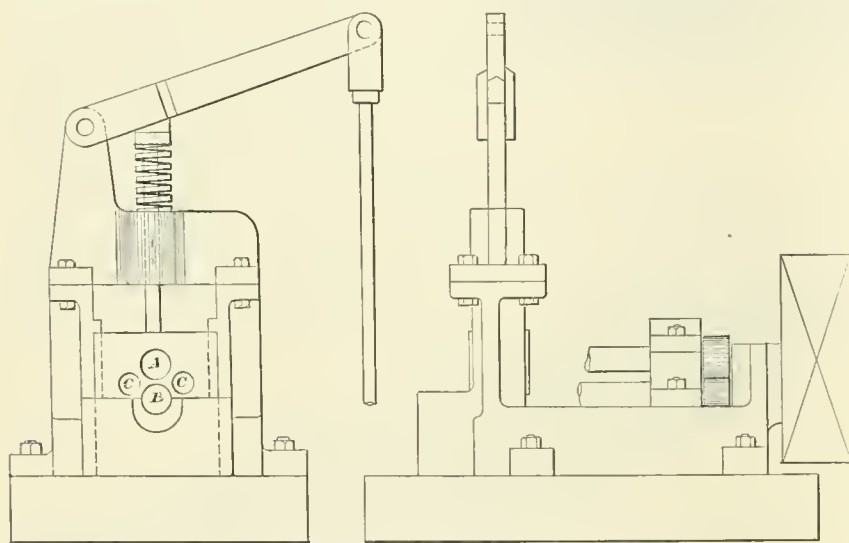

FLUE EXPANDING AND SWAGING MACHINE.

the bottom of the smoke box about six inches diameter which did not affect their steaming capacity.

Mr. Mellon and Mr. MacBeth confirmed this arrangement on other engines.

Professor Goss could not explain how the engines could steam.

Mr. Tunkey said that in old times when they had an engine that did not steam, they put on an inch smaller stack and had no more trouble.

Mr. Owens said that on a road he was connected with a few years ago they had some new engines with wide fire boxes and a high single nozzle that did not steam. They took out the high nozzle and put in low double nozzles and the engines were then a decided success.

Mr. Thayer's experience on the Wabash with low nozzles was different from that of other speakers. They have engines with high nozzles that are

Mr. Owens mentioned a case where a lot of engines were built for a western road to burn a very inferior quality of coal. They steamed very badly and a variety of changes were made without improvement. Then grates with larger openings were put in and the engines made steam freely. He held that the character of the grates ought to be considered in connection with draft appliances.

Professor Goss did not consider the grates or the character of the fuel has any close connection with the subject of locomotive front ends. They have a bearing on the steaming qualities of a locomotive, but he had not been discussing the question of the steaming of a locomotive. He had regarded the front end mechanism simply as a mechanism for moving gases. The effort has been to so proportion this machine that the greatest volume may be drawn against a given difference of

Machine for Expanding and Swaging Flues.

The accompanying engraving shows a very satisfactory tool which is in use in the Pittsburgh shops of the American Locomotive Company for expanding and swaging flues. It is a simple machine operated by belt power and consists of four rolls one of which, marked B, is used at all times, the others carried in

a guide are raised and lowered by a treadle. When it is desired to expand a flue it is put on roller B and roller A is brought down upon it and a few turns of the tube complete the operation. For swaging, rollers C C are brought in contact with B, which has a shoulder at the portion with which roller C C come in contact. A few turns of the machine does the work quickly and expeditiously. The whole arrangement is mounted on a long table for convenience in handling tubes. The machine was made at the works.

Passenger Power for the Atlantic Coast Line.

The Atlantic Coast Line Railroad, of which Mr. J. S. Chambers is superintendent of motive power, has recently had seven passenger engines of the 4-6-0 type built at the Baldwin Locomotive Works. The engines are practically

ft. in the tubes. There are 290 tubes, each 14 ft. 5 ins. long. The crown sheet slopes slightly down toward the back. A few of the principal dimensions are as follows:

Cylinders—19x26 ins.

Valve—Richardson-Allen, balance.

Boiler—Thickness of sheets, $\frac{5}{8}$ in.; working pressure, 200 lbs.; fuel, soft coal; staying, radial.

Fire Box—Length, 96 $\frac{1}{2}$ ins.; width, 42 ins.; depth, front, 69 $\frac{1}{4}$ ins.; back, 67 $\frac{1}{4}$ ins.; thickness of sheets, sides, $\frac{3}{4}$ in.; back, $\frac{3}{4}$ in.; crown, $\frac{1}{2}$ in.; tube, $\frac{1}{2}$ in.; water space, front, 4 ins.; sides, 3 ins.; back, 3 ins.

Heating Surface—Fire box, 162 sq. ft.; tubes, 2,174 sq. ft.; total, 21,336 sq. ft.; grate area, 28 sq. ft.

Driving Wheels—Diameter outside, 68 ins.; journals, 8 $\frac{1}{2}$ x 10 $\frac{1}{2}$ ins.

Engine Truck Wheels—Diameter, 30 $\frac{3}{4}$ ins.; journals, 5 ft. x 10 $\frac{1}{2}$ ins.

Wheel Base—Driving, 13 ft. 6 ins.; total engine, 24 ft. 4 ins.; total engine and tender, 51 ft. 6 ins.

Weight—On driving wheels, about, 106,000 lbs.; on truck, front, about, 39,000 lbs.; total engine, 145,000 lbs.; total engine and tender, about, 245,000 lbs.

Tank—Capacity, 5,000 gals.

drop the smattering of silly isms that are taught to common-school children and give them instruction in physics.

Some railway officials have displayed much kindness towards suggestions that their repair shops should be made of sufficient capacity to build all the new cars and locomotives required by the company. They are certain that the work could be done so cheaply that much money would be saved to the companies interested. This brings to our recollection the remarks made by the superintendent of motive power of a great railroad who had been occasionally ordered to build new locomotives. "We always could show," remarked this veteran, "that we could build the engines more cheaply than the company could buy them, but somehow the cost of repairs always rose considerably when new work was occupying the shop."

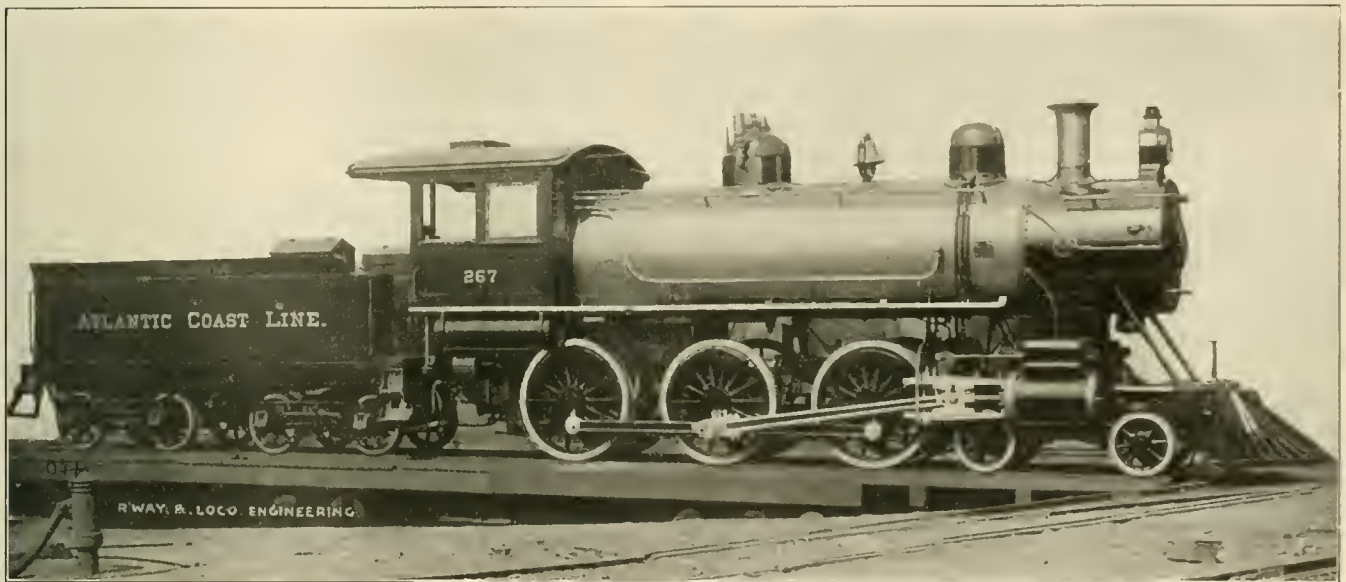

BALDWIN SIMPLE TEN WHEEL ENGINE FOR THE ATLANTIC COAST LINE.

duplicates of some engines which were supplied on a previous order.

The engines are simple, with Allen-Richardson balance valves. The cylinders are 19x26 ins. and the driving wheels are 68 ins. in diameter. All the wheels are flanged and the driving springs are between and under the frame bars with the exception of the leading drivers which have their springs on top of the box in the usual way. The drivers are equally spaced, which adds to the appearance of the machine. The motion is indirect, the transmission bar passing below the first driving axle to a rocker arm.

The boiler is a straight top one, and is 62 ins. in diameter at the front. The grate area is 28 sq. ft. and there is in all 2,336 sq. ft. of heating surface made up of 162 in the fire box and 2,174 sq.

Acquiring Useful Knowledge.

The bicycle and now the automobile have performed valuable service to the people in giving them practical instruction on mechanical principles. The labor spent on struggling to make a balky machine go imparts sound instruction on mechanism.

Another thing that is imparting sound knowledge on mechanical matters is the technical schools and industrial educational establishments that are springing up all over the country. This will have a wholesome effect in preventing people from being decoyed into taking financial interest in schemes that are impracticable and based on claims of action that are contrary to the laws of nature. It will be bad for the people pushing perpetual motion schemes. What is now more desirable than any other line of education is to

Patented Appliances Discussed in Railroad Clubs.

There is a growing tendency among railway clubs to accept and discuss papers describing proprietary articles for railroad use, a means of free advertising which is very effectual and valuable to the parties most interested. This is an innovation in which railroad club men follow an example long given by the American Society of Mechanical Engineers and other organizations of a like character, but it is hardly worthy of commendation.

We do not blame proprietors of railroad appliances for advertising their wares through papers presented to railway clubs, but we think that all railroad men should strenuously object to the practice becoming common of speakers at railroad clubs discrediting the value and utility of certain proprie-

tary devices while commending those made by rival companies. While disguising the names of the speakers and of the appliances, we are moved to comment on a discussion at a railroad club lately, where Mr. Wilson made a most serious attack upon the Watson oil box, which is regarded all over the country as one of the best of its kind. He commended zealously the Williams oil box, which has not yet gained much of a reputation. Oil boxes then became the subject of general discussion, and some very disparaging things were said about boxes that stand well with most railroad communities. All the discussion was published verbatim by the secretary, and some oil-box interests received unmerited wounds, while others received surprising praise. The whole thing is grievously unfair, for the friends of the discredited devices are seldom on hand to defend their property.

feet to the first limb. The trees of these dimensions cut from 135,000 to 180,000 feet, board measure.

On the way up to the Big Trees on the Eureka & Klamath River Road, with Gen. Supt. C. W. Root and Master Mechanic C. J. Chapman, my attention was called to a two-story house and large barn, and fence around a ten-acre lot, that were all built by lumber from one tree, and enough fuel to last two years. The stump is still standing near the house.

The tree after it is felled is sawed into lengths of 16 to 18 feet, then the bark is taken off, and handled by a steam donkey. The bull donkey is a double engine of 16 ins. or 18 ins. x 22 ins. or 24 ins., with a 1½ wire cable from a 2½ to 3 miles long. This cable is drawn back to where the logs are to be drawn to the loading platform by a wire cable, with one of the small logging steam donkeys.

vails concerning the advisability of the Interstate Commerce Commission taking a hand in matters pertaining to safe train operation.

A metropolitan daily in a recent issue referred to the "holding up" of a train in Florida not long ago, and the dynamiting of the baggage car, which the desperadoes mistook for the express car. A day later, obstructions were with felonious intent placed on the tracks of the Louisville & Nashville, and on the same day an operator on the Lake Shore road was bound, gagged and robbed at a point not more than twenty-six miles from Buffalo.

Such assaults are not only outrages upon the person and liberty of the immediate victims, but the destruction of railway property or the injury to a responsible railway employee in the discharge of his duty, endangers the lives of the traveling public. Often the prox-



OLD WAY OF HAULING.



NEW WAY OF HAULING.

If for "oil box" one reads "draft attachments of cars," no mistake will be made.

Cutting Down the Big Trees.

I send you photographs of the big redwood trees in Humboldt County, California, showing the mode of handling them and how they are cut down and cut in lengths and handled in the woods. They first build a staging about 8 feet above the ground, then chop the bark off, where they wish to saw the tree down. The bark on the largest trees is 14 to 18 inches thick, is of soft, spongy material, and makes fine pin-cushions. The sawyers are expert at felling the trees. They can fell the trees so the top of the tree will come within 4 feet of where you will drive a stake. The trees of 14 feet in diameter grow to the height of 300 or 325 feet high, those of 18 feet in diameter 350 to 375 feet high. The trees grow very straight and it will be 150 to 200

All the logs are handled by steam power, as they cannot be handled by men. They are drawn to the mill and unloaded into Humboldt Bay. The railroad runs on a trestle over the bay, and where the cars are unloaded one rail is elevated so as to tip the car about 18 or 20 ins. and the log rolls off the cars into the bay.

The density of this redwood may be judged from the fact that the first three logs at the butt of the tree will not float and are called "sinkers" by the lumbermen. The logs are floated to the sawmills and are cut up by huge circular saws. The machinery is driven by an engine of 1,000 h.p. The main belt is 6 ft. wide, 119 ft. long and cost \$1,993.25. The hides of 272 cattle were used up in making this belt. W. C. CHAPMAN.

Train Robbers and Train Wreckers.

One cannot take up a daily paper just now without being struck with the wonderful unanimity of opinion which pre-

imity of the state boundary line assists train robbers and wreckers in escaping into what practically becomes neutral territory until legal formalities have been complied with, which latter often consume time.

There should not even be temporary territorial asylum for the train wrecker or train robber anywhere in the United States. While the strong arm of the law, and only the strong arm of the law should deal with him as he deserves, it would seem that the popular demand is now turning toward the enactment of some suitable statute by which the Federal power may be invoked to make the way of this particular form of transgressor hard in the extreme.

Train wrecking and train robbing flourished in Mexico until the national government of that country made it a capital offence, and then the outrages stopped. By the government following up steadily and always hanging men convicted of outrages on railways, that

country eventually ran out of this variety of desperado, much to the satisfaction of the public at large.

Forged Rolled Steel Car Wheel.

The Wheeler Forged Rolled Steel Wheel Company, with office at Pittsburgh, Pa., was organized in June, 1903, for the purpose of supplying the demand for a "one piece" car wheel of steel as a substitute for the ordinary cast iron wheel under steel freight cars.

The uncertainty in the use of iron and steel castings, when used for car wheels under modern conditions of load and

same characteristics as to quality of metal as the steel tire of the several types of the latter wheel, being made from a solid round ingot of the same standard, quality, shape and diameter as those from which tires are made. The product will have as much and similar forging and rolling as a tire gets.

The diameter of the ingots used are about 16 ins., thus giving 17 ins. of work in drawing the wheel blank out to finished diameter of 33 ins. The shrinkage cavities will be in the center and near the top of such an ingot, but in a "casting" of the shape of a wheel the cavities or blow holes are nearly all in

called muffling, is used, and which is said by well known engineers to be the secret of success in one-piece wheel manufacture. This process, as well as the improved tire mill, which is adapted to rolling solid wheels, was developed several years ago and patented by Frank A. Wheeler, of Pittsburgh, Pa. He was formerly in the steel tire departments of the Latrobe Steel Company, and of The Midvale Steel Company.

A Chinese carpenter always bores a hole before driving a nail, and manages, by steady industry, to drive 100 nails for a day's work.



CUTTING DOWN THE GIANT TREES.

speed, is now well known. It is impossible to submit each such cast wheel to a test sufficient to determine its safety without destroying it in the process. With a forged and rolled wheel made under the Wheeler system of manufacture, each wheel is put through such severe manipulation that any imperfection in the ingot, or in blanks, may surely be detected at some stage of the work.

This forged and rolled wheel has the

rim, which weakens the wheel and makes it spongy. The wheel made by this company is in no sense an experiment, being the logical development of the steel tired wheel into "one piece" instead of being in several parts. The wheel rolling mill used is more powerful than any tire mill now in use, and will be able to roll the hard steel required at a uniformly low cherry heat.

A peculiar process of heat treatment for the forged blank before rolling,

A French philosopher, writing about the steam engine, says: Is not invention the poetry of science? All great inventors carry with them the ineffaceable mark of poetic thoughts. It is necessary to be a poet to be a creator. If a radical improvement is required on any great machine, like the steam engine, we think that the work will be achieved rather by a man of strong imagination than by a serious specialist.

Rough Track.

Delays of trains from a variety of causes had become unbearable and the general manager had called a conference of heads of departments to give reproofs and listen to excuses.

"Mr. Jones," said the G. M., addressing the superintendent of motive power, "I notice that a large proportion of the train delays are attributed to leaky tubes. What have you got to say for your side?"

"Well, sir," answered Mr. Jones, "my department is holding up its end all right, but the road master is to blame for that trouble. Why, sir, the track is so rough that it shakes the tubes loose in the boilers."

Running Past Extinguished Signal Lights.

Certain trainmen on the Chicago & Northwestern have been worked to pro-

no less than eight trains had whizzed along. This included the fine Northwestern Limited for the coast. After the trains had passed the lights were again lit and the officials went back to headquarters and laid off all of the eight train crews for ninety days.

The experiment was quite a safe one to make, because at that particular place the tracks are double and everything tonight was clear; but the crews were nevertheless violating one of the most important rules of the road, and the punishment will be used as an object lesson for the entire system.

To-morrow general warnings and new orders will go out, and hereafter those violating this rule or any others of like importance will be dismissed forever from the service of the road.

Printer's Ink.

Printer's ink, considered as a lubricant for what Dr. Holmes has happily

hoarded sunshine locked up in the growing plant uncounted centuries ago, is given forth again as light and heat when the carbon atoms in the coal we throw upon the fire rush to the embrace of the oxygen atoms they parted from when this old world was young. How startling this phenomenon in the case of printer's ink, when its black carbon atoms, warmed to ignition by the divine spark of human intelligence, are mingled with thought, and flash forth from the printed page to illuminate the world and drive the wheels of industry with constantly accelerating speed. There is something more in this than the releasing of the wound spring or the liberation of the suspended weight; something more than that which we note in the physical phenomenon of combustion—a return of the power in carbon into the forms in which, as light, heat and actinic force, it was absorbed and held by the vegetation of



CUTTING DOWN THE BIG TREES.

vide an object lesson to the same class of men all over the country, if the following press dispatch to the *New York Times* is true:

CHICAGO, Jan. 7.—Stirred by the Père Marquette wreck, which was caused by a train crew disregarding the fact that the semaphore signal had gone out, which should have caused them to stop their train, Northwestern Railway officials to-night decided to make a secret test of the fidelity of their men.

At Mayfair, a station just inside the western city limits and on the main line of the Northwestern, the officials took possession of the station and to the astonishment of the agent put out all the semaphore lights. When a semaphore light is out it is the same as the red danger signal, and all trains should stop for orders.

To the chagrin of the officials, one passenger train after another passed by without the slightest slowing up until

called "the racked axle of art's rattling car," is undoubtedly the one which has the least co-efficient of friction. It is the best of lubricants for the ways in which great undertakings are launched, and for the grooves along which profitable effort is exerted. What incalculable losses of power does it not avert, and who can estimate the friction which, without it, would wear out our lives in useless work! Civilization would be like Penelope's web, woven by day and raveled out by night, showing no gain; and the tedious years would come and go empty handed, leaving us still traversing with weary feet the pathways worn by preceding generations.

But it is not only as a lubricant that printer's ink merits the attention of the engineer. We must consider it as a source, as well as a conservative of power. It has been the pleasure of many writers to tell us how the

early world. As letters on the printed page we see union of carbon with some part of that all-pervading creative intelligence which, as matter, it knew only as a law of nature, and by this union it becomes the true *elixir vitae* of the alchemist's dream. While we have it truth cannot die nor civilization retrace its steps.

Notice has been given a bill will be introduced into the House of Lords of the British Parliament at an early date making the use of the Metric System of Weights and Measures compulsory. The advocates of the Metric System in Great Britain have been struggling for years to introduce compulsory legislation through the House of Commons, but the business men of that chamber could not be worked for the fad. Now the fossils of the Upper House are invited to father a measure which the people at large repudiate.

Of Personal Interest.

Mr. L. E. Hassman has been appointed to the position of general foreman of the Carbondale, Ill., shops of the Illinois Central Railroad.

Mr. M. M. Richey has been appointed assistant general superintendent of the Western District of the Southern Railway, with office at Birmingham, Ala.

Mr. A. P. Garrison, an engineer on the Grand Rapids and Indiana Railroad, has been appointed to the position of traveling engineer on the same road.

Mr. F. L. Distelrath has been appointed general foreman of the Toledo & Ohio Central shops at Columbus, Ohio, vice Mr. W. R. Davis, resigned.

Mr. Geo. S. MacKinnon, formerly master mechanic of the Central Division of the Canadian Pacific Railway, at Winnipeg, Man., has resigned his position.

Mr. Ellis C. Spoker, the expert in cement plants, has become associated with the Engineering Co. of America, with headquarters at their Chicago office.

Mr. Frank H. Dunlop has been appointed passenger agent for the Chicago Great Western Railway, with headquarters at 1512 Farnam street, Omaha, Neb.

Mr. Jas. W. Leonard, formerly assistant general manager for lines west of Lake Superior, on the Canadian Pacific, at Winnipeg, has resigned his position.

Mr. C. F. Bishop has been appointed road foreman of engines on the Chautauqua Division of the Pennsylvania Railroad, vice Mr. J. A. Kennedy, resigned.

Mr. J. A. Warner has been appointed superintendent of the Highland Division of the New York, New Haven and Hartford Railroad, vice Mr. T. H. Fennell, transferred.

Mr. C. C. Elwell has been appointed superintendent of the Shore Line Division of the New York, New Haven & Hartford Railroad, vice Mr. J. V. A. Trumbull, resigned.

Mr. W. L. Calvert has been appointed master mechanic of the first division on the Denver & Rio Grande Railroad, with office at Denver, Colorado, vice Mr. David Patterson, resigned.

Mr. David McNicoll, general manager of the Canadian Pacific Railway, has been elected vice-president of the company. He therefore became a member of the board of directors.

Mr. R. J. Quintrell has been appointed master mechanic of the San Francisco & Northwestern Railway, with headquarters at South Bay, Cal., vice H. Whitham, resigned.

Mr. S. Rothwell has been promoted to the position of roundhouse foreman on the Brockville, Westport & North-Western Railway, with headquarters at Brockville, Ont., Canada.

Mr. Geo. A. Bruce has been appointed general master mechanic of the Eastern District of the Great Northern Railway Line, with office at St. Paul, Minn., vice Mr. Thomas Roope, resigned.

Mr. B. R. Pollock has been appointed superintendent of the Air Line, Northampton Division, of the New York, New Haven & Hartford Railroad, vice Mr. C. C. Elwell, transferred.

Mr. J. J. Cavanaugh, an old and valued subscriber to RAILWAY AND LOCOMOTIVE ENGINEERING, has lately accepted the position of roundhouse foreman at Mexico City, on the Mexican Central Railway.

Frank H. Whitney, formerly air brake inspector on the Eastern District of the New York, New Haven & Hartford, has been appointed road foreman of engines of the Plymouth Division of the same road.

Mr. H. M. Deavitt, analytical and consulting chemist and assayer, with a large practice in Chicago, has taken the management of the Chicago office of the Engineering Co. of America, 159 La Salle street.

Mr. J. W. Reading has resigned the position of superintendent of the Manistee & Grand Rapids Railroad, and has moved to 89 Mechanic street, Grand Rapids, Mich., where any of his friends can find him.

Mr. James E. Young has been appointed road foreman of engines, having jurisdiction between Cartier and Fort William, on the Lake Superior Division of the Canadian Pacific, with office at White River, Ont.

Mr. Geo. F. Randolph was, at a meeting of the executive committee of the board of directors of the Baltimore & Ohio Railroad, elected first vice-president of the company, vice Mr. Oscar G. Murray, promoted.

Mr. C. W. Jones has been appointed road foreman of engines on the San Joaquin Division of the Southern Pacific Railroad, vice Mr. C. R. Petrie, whose

duties will hereafter be confined to the Los Angeles Division.

Mr. W. T. Noonan having resigned, the position of superintendent of the Minneapolis & St. Louis Railroad has been abolished. Officials and employees have been instructed to report direct to the general superintendent.

Mr. H. B. Crandall has been appointed fuel agent of the Lehigh Valley Railroad and their operated and controlled lines, and will be in charge of the purchase of all fuel coal, with office at 26 Cortlandt street, New York.

Mr. Wilber P. Garabrant, general air brake inspector on the N. Y. division of the Pennsylvania Railroad, has gone to Paris to attend to the construction of De Glehn compound engine, which is being built for the Pennsylvania.

Mr. W. F. Buck has been appointed master mechanic on the Atchison, Topeka & Santa Fe, at Needles, Cal., vice Mr. H. Schaefer, resigned. Mr. Buck was formerly master mechanic on the Northern Pacific, at Missoula, Mont.

Mr. W. L. Brazier, for years a prominent engineer on the Boston & Maine, at Boston, has been appointed traveling engineer on the western section of the Fitchburg Division of the B. & M., with headquarters at Mechanicsville, N. Y.

Mr. Edward Everett, civil engineer, who has specialized in railroad work, and who made the survey for one of the Hudson river tunnels, has become associated with the Engineering Co. of America's New York office, 74 Broadway.

Mr. F. A. Symonds has been appointed foreman of the shops of the Louisiana & Arkansas Railway, at Stamps, Ark. Mr. Frank Cain having resigned the position of master mechanic on that road, the position has been abolished.

Mr. T. H. Fennell has been appointed superintendent of the Hartford Division of the New York, New Haven & Hartford Railroad, vice Mr. C. S. Davidson, placed on the retired list by vote of the board of directors, after fifty-two years of active service.

Mr. P. J. Fahey, formerly an engineer on the S. & N. A. Division of the Louisville & Nashville, has been promoted to be traveling engineer on the same road with territory from Decatur, Ala., to New Orleans, La., including all branches between these points.

Mr. C. L. Rose, superintendent of tracks, bridges and buildings, of the San Francisco & Northwestern Railway, has resigned, and the office has been abolished. Mr. W. F. Stelzreide has been appointed road master, with headquarters in Eureka, Cal.

Mr. H. S. Bryan has been appointed to the position of superintendent of motive power of the Duluth & Iron Range Railroad, and in this connection it may be stated that the office of master mechanic has been abolished and the office of superintendent of motive power created.

Mr. Benjamin Johnson, superintendent of machinery of the Mexican Central Railway, announces that his office has been moved to Aguas Calientes. Mr. Johnson remains as heretofore superintendent of machinery. We hope the change of location will be both profitable and pleasant.

Mr. Charles W. Hull, heretofore traveling engineer on the Boston & Maine, with office at Boston, Mass., has been appointed master mechanic of the Connecticut & Passumpsic Division of the same road, with headquarters at Springfield, Mass., vice Mr. C. L. Aiken, transferred to Lawrence, Mass.

Mr. Jos. Billingham, master mechanic of the Ohio River Division of the Baltimore & Ohio Railroad, with headquarters at Parkersburg, W. Va., has resigned, to accept position with the Galena Signal Oil Company, of Franklin, Pa. He will shortly go abroad to represent their interests in Great Britain and Ireland.

Mr. A. P. Pendergast, master mechanic on the Baltimore & Ohio, heretofore with office at Grifton, W. Va., has been transferred to Baltimore in a similar capacity, vice Mr. O. J. Kelly, who has been appointed master mechanic of the Ohio River Division, with headquarters at Parkersburg, W. Va., vice Mr. J. Joseph Billingham, resigned.

Mr. William Whyte has been elected second vice-president of the Canadian Pacific Railway, with office at Winnipeg, in general charge of the maintenance and operation of the company's western lines, and, under the president's direction, of the administration of the company's affairs in the territory between Lake Superior and the Pacific Coast.

Mr. A. M. Bell, of London, who has been a frequent correspondent of RAILWAY AND LOCOMOTIVE ENGINEERING, has been appointed Carriage and Wagon Superintendent of the Peninsular Railway at Bombay, India. Mr. Bell was for about 20 years on the Great Eastern Railway of England, and about half that time assistant to Mr. Holden, the loco-

motive superintendent. He has traveled in the United States and has many acquaintances among our railway men.

Col. John T. Dickinson, heretofore general agent, was, at a meeting of the board of directors of the Consolidated Railway Electric Lighting & Equipment Company, held January 13, elected second vice-president, in charge of negotiations with railway companies for the use of the Consolidated "Axle Light" system of electric car lighting. The company's general offices were recently moved from 100 Broadway to the Hanover Bank Building, corner Pine and Nassau streets, New York City.

Mr. N. S. Braden, formerly manager of the Westinghouse Electric & Manufacturing Company's District Office, at Cleveland, Ohio, has been appointed sales manager of the new Canadian Westinghouse Company, Ltd., and assumed the duties of that office on January 1, 1904. Mr. Braden succeeds the late Thomas C. Freneyar. Mr. Braden has made his headquarters at Hamilton, Ont. He finished his schooling in 1892, and went with the Jenny Electric Motor Company, in Indianapolis, and remained with that company until 1899, when he joined the Cleveland District sales office of the Westinghouse Electric & Manufacturing Company, as a salesman, where he later became manager. Mr. Braden is known as one of the ablest and best informed electrical salesmen in America.

Obituary.

Mr. Thomas Cyprian Freneyar, sales manager of the new Canadian Westinghouse Company, died of typhoid fever at Fort William, Canada, last December. He was a man of exemplary life, unusual judgment and ability, and was remarkable for the clearness and force of his ideas. As an electrical engineer he was a good adviser. His is the first death in nearly five years among the higher officials of the Westinghouse Electric Company. Mr. Freneyar was the son of the Rev. T. C. Freneyar and was born on March 16, 1865, at Middletown Spa, Vermont. He began his business career before he was 15 years old, in the office of the Boston Electric Company, where an uncle, Mr. W. R. Nutting, was manager. In the fall of 1895 he entered the employ of the Westinghouse Electric & Mfg. Co. He was connected with the sales office of that company until November 1, 1903, when he was placed in charge of the sales department of the new Canadian Company, with headquarters in Toronto. In announcing the death to this official of the Westinghouse Company, Vice-president Taylor said: "The management desires to place on record its thorough appre-

ciation of his able and loyal service, and of the loss to the Westinghouse interests by the untimely removal of a young and zealous official whose future seemed so full of promise."

Calvin A. Smith.

Calvin A. Smith, so well known to railroad men, first, through his long connection as secretary of the Master Car Builders' Association, and afterward as treasurer of the New York Railroad Club, died last month at his home in East Orange, N. J. Mr. Smith was one of the best known railroad mechanical officials in his time, and through his persistency in keeping the Master Car Builders' Association alive when it was in a moribund condition, he deserved the gratitude of all the railroad interests that have been promoted by the work of the Master Car Builders' Association. Mr. Smith was born in Maine in 1822 and spent the first 18 years of his life on his father's farm. He appeared to have had such an aptitude for mechanical work that he left there and engaged in carpenter work, in competition with trained carpenters, though he had no special training as a carpenter. When the Erie Railroad reached Dunkirk in 1851, he went to work in the car department and he made his mark so strongly that two years later he was sent to Piermont, the eastern terminus of the Erie, as master car builder, in charge of the car department. While with the Erie Mr. Smith designed and supervised the building of what was a famous car in its time, the "Metropolis," in which Col. James Fisk and Jay Gould were much interested. It was one of the first parlor cars introduced on railroads. Mr. Smith also patented a brake in which Col. Fisk took great interest and which was about to be introduced when Col. Fisk came to his untimely end. Mr. Smith left the Erie to take the position of master car builder of the Union Tank Line, which is controlled by the Standard Oil Company, and he remained in that employ until about a year ago when he was retired on a pension.

A new factory for Spokane, Wash., which will represent a capital in the neighborhood of \$100,000, is designed and the plans are now being worked out. Articles of incorporation of the Motor Traction Company were filed in the office of the county auditor last month. The objects of the new organization, as explained in the articles, are to manufacture, equip, run, sell, operate and deal in all kinds of motor and traction cars, road wagons, vehicles, steam engines and boilers, and to conduct a foundry and machine shops, iron, wagon and carriage factories.

Air Brake Department.

CONDUCTED BY F. M. NELLIS.

Series Arrangement of Air Pumps at Mayfield Shops, New York, Ontario & Western Ry.

The accompanying illustration shows an arrangement where two air pumps are connected in series; that is, one pump draws from the atmosphere, compresses into a reservoir, and a second pump draws from this reservoir and compresses into a second reservoir. The pumps are secured in a convenient position, such as shown in the illustration, each pump being supplied with live steam from the boiler in the usual manner.

The governor is connected to the steam admission of the high pressure pump, and is actuated by the final discharge pressure, so that when it reaches a certain fixed amount, the high pressure pump stops, and the low pressure pump will also stop as soon as the pressure in the intermediate reservoir reaches an amount equivalent to the steam pressure reduced to the area of the air piston.

It is essential that the intermediate reservoir and air pipe between the two pumps should have sufficient radiating surface to cool the air discharge from the low pressure pump to a temperature as near as possible to that of the surrounding atmosphere. This not only increases the efficiency of the plant, but greatly reduces the heat generated by the second, or high pressure pump.

Continuance of a Fraudulent Practice.

There is being practiced under the Master Car Builders' rules an old deception of marking the triple valve and brake cylinder "Cleaned and oiled" when the work has not been performed.

In past years, when this deception was practiced, it resulted in damage only to that extent which kept the parts from being properly and honestly cared for by other men who would gladly and willingly do the work, had not the marking positively asserted that the work had been actually and honestly performed. In the past this deception did this damage and no more, but now, under the new M. C. B. rules where one road is allowed to charge another for air brake work performed, and render a bill for the same, the dishonest practice becomes really criminal. It reports work performed which was not, and entitles that road to collect charges to the extent specified by the rules of the Master Car Builders' Association. This is

plainly a crime, as money is collected under false pretenses. It seems unnecessary to say that this dishonest practice needs rigorous treatment and demands a suitable punishment of the offender.

In doing the work honestly, the man must not remove the oil plug and pour oil in the oil hole, for the M. C. B. rules specifically stipulate that the piston must be removed, cleaned, lubricated with some good lubricant, grease preferred, such as Marvin's Compound, and replaced. The mere removing of the cap of the triple valve, wiping off the inner parts and oiling them while on the car,

about the year 1895, when a hand-braked train ran into and telescoped a train that was standing on the track ahead of it, thereby killing several people, and doing a great deal of damage. At that time it was the custom of the Government Railway Department to equip only their passenger trains with the air brake, leaving the freight brakes to be applied by hand. In course of the inquiry that followed this freight-train disaster, the Emperor asked the Minister of Ways and Communications to explain how it had happened, and that official stated that if

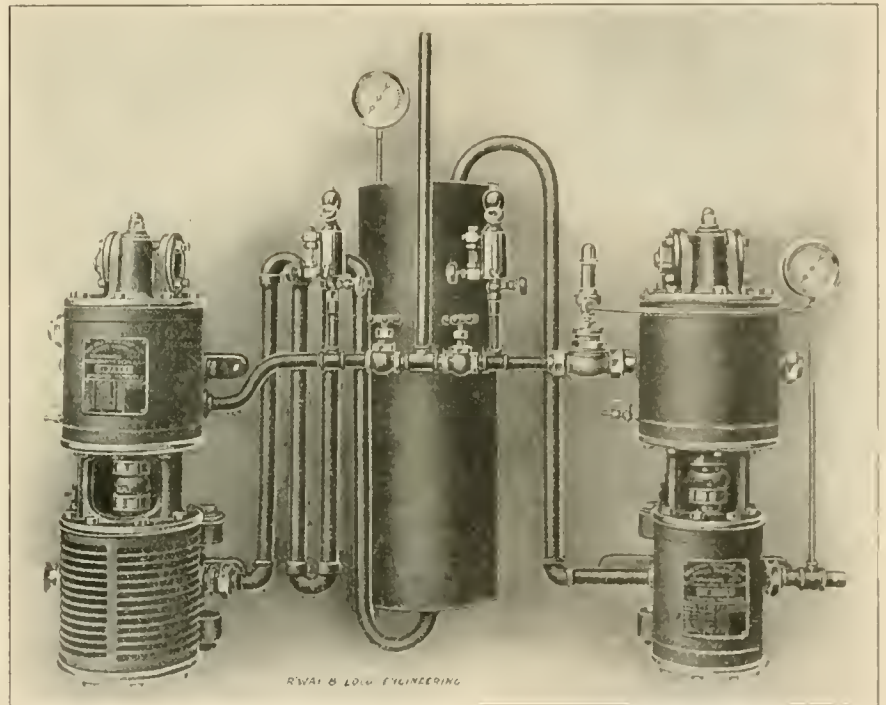

ARRANGEMENT OF PUMPS FOR PUMPING A HIGH PRESSURE OF AIR WITH LOW STEAM PRESSURE FOR SHOP PURPOSES.

will not do. The triple valve must be removed from the auxiliary reservoir or brake cylinder, cleaned, oiled and tested. If this is not done, the person otherwise performing the work has no right to collect the price allowed by the M. C. B. Association.

American Brakes in Russia.

The manner in which the equipment of the Russian railways with American air brakes received its greatest impetus has not been widely known, and may be of interest to our readers.

A very serious accident occurred on one of the Russian State railways

the freight service also had been equipped with American automatic air brakes the accident would not have occurred. To this the Emperor replied: "Why were they not so equipped?"

Such a reply from that monarch was equivalent to a command. All the previous troubles in the way of lack of funds were speedily put to the vanishing test, and a commission was formed from the Ministry of Ways and Communications to study up and recommend the best automatic air brake.

After some time this commission decided to put to the test five companies who were competing for the five-year

contract for \$7,000,000 worth of brakes which the Government needed at that time. They, consequently, invited each company to send equipments for a fifty-car train, which was to be equipped with each type of brake in turn, and put through the same series of tests. As a

order was for 1,000 sets of Westinghouse locomotive brakes. The policy of the Russian Government demands that all material which is to be used in connection with Government contracts must be made in Russia, by a Russian company. There is no other Russian brake company in existence at the present time than the Westinghouse. None other has received a charter.

the commencement of the stop where the train is running nearly 80 miles per hour; the second, a section at the middle of the stop, where the speed of the train is about 65 miles per hour; and the third box, a section of the speed curve at the finish of the stop.

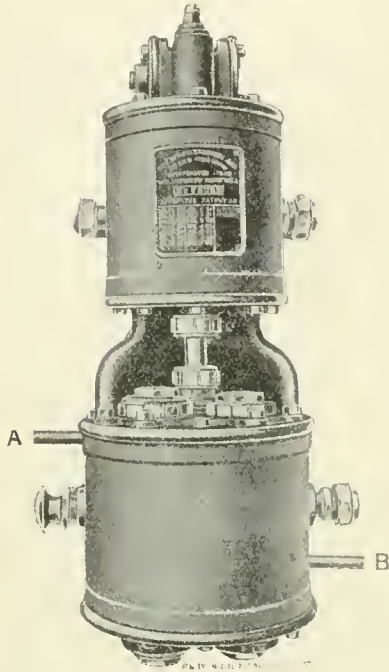

AN AIR PUMP WITH A WATER JACKETED AIR CYLINDER.

result, the Westinghouse Air Brake was chosen, and as the Government contract stated that the brakes should be made in Russia, a Westinghouse factory was at once started at St. Petersburg. From the day that the report of the commission was accepted to

Air Pump With Water Jacketed Air Cylinder.

In cases where air pumps are called upon to run continuously in shop service with an air pressure exceeding 100 lbs., the Westinghouse Air Brake Company has arranged to furnish pumps with specially water-jacketed air cylinders, also where the conditions are such as to demand a low air pressure with comparatively high steam pressure, and consequently a higher speed than usual. In working continuously under these conditions, the pump shown in the accompanying illustration is recommended, as it is supplied with a water-jacketed air cylinder. The air valves in this pump are placed in the center piece and lower head, as will be observed by the illustration. The water connections are made at the pipes, *A* and *B*, the water entering at *A*, passing around through the jacket and leaving at the outlet *B*.

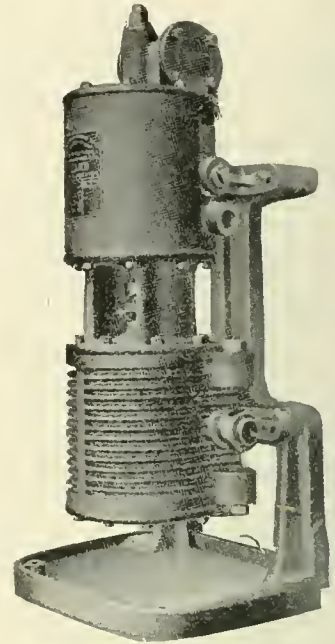

3/4 INCH PUMP MOUNTED ON SPECIAL STAND WITH DRIP PAN.

To give greater ease of reference, these rectangular boxes and their sections of the speed curve have been lifted

Brake Retardation at Different Periods of the Stop.

The speed curve of an air brake stop card tells many interesting things to the student who sufficiently exerts himself to analyze it. Next to the graphic tale told by the collision energy line in the comparative value of two stops, will perhaps come the different degrees of retardation of the brakes at different periods of the stop.

The average air brake man, after finishing his gaze of a stop curve on a card, if asked whether, in his opinion, the brakes hold better at the beginning of the stop or the finish, will reply in a manner which clearly indicates that his answer is not associated in any way whatever with what he has just seen on the card. Then, when his attention is directed to the curve, he will readily see that the rate of retardation is much greater at the finish of the stop and less at the beginning. It is the purpose of this discussion to make prominent these facts:

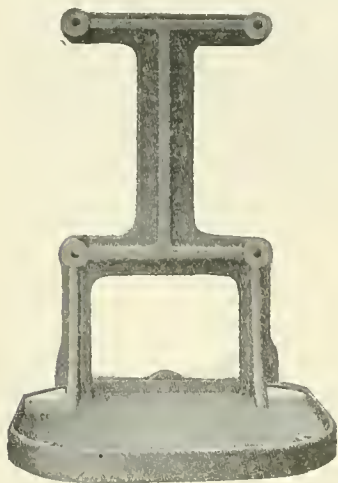

AN AIR PUMP STAND FOR PLACES WHERE WALL ROOM OR OTHER SPACE IS LACKING.

this, the Westinghouse Company has supplied all the railway brakes for the Russian Government.

A statement was recently made that a large order for locomotive brakes had been given to a competing American concern, but this is erroneous. The

Fig. 1 is a speed curve of a three car train being brought to a stop with the high speed brake from a speed of nearly 80 miles per hour. The heavy lines, describing the rectangular boxes, enclose three sections of the speed curve. One box contains a section of the curve at

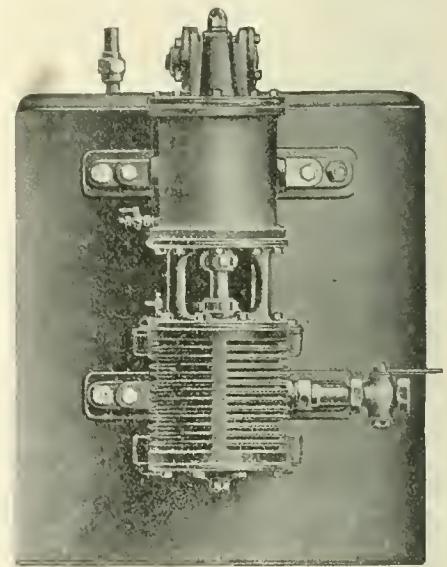

A NEAT ARRANGEMENT OF AN AIR PUMP MOUNTED ON A MAIN RESERVOIR IN AN AIR BRAKE REPAIR ROOM.

out at Fig. 1, and are reproduced and enlarged in Figs. 2, 3 and 4.

Fig. 2 shows a section of the speed curve and illustrates the braking that was being done during the first 300 feet of the stop. The figures in the column at the left indicate the speed in miles per

hour. As will be observed, the speed of the train in passing over the first 300 feet, after the brake was applied, was reduced from 70 to 72 miles per hour approximately, and for the third 100 feet was reduced about 2 miles per hour. It should be observed that the speed curve gradually drops away from a horizontal direction.

Fig. 3 illustrates, in a similar manner, that portion of the speed curve taken from the middle of the stop, or that portion of the stop lying between the 900 ft. and 1,200 ft. distance stakes. The general position of this section of the curve shows a further tipping down or falling away from horizontal position. The brakes are manifestly doing more effective work. The train enters the 900 ft. section at a speed of 58 miles per hour and passes out of the 1,200 ft. section at 49 miles per hour, the speed being

running at a speed of 33 miles per hour when it passed the 1,750 ft. mark. Through the last 300 ft. the speed was reduced from 33 miles per hour to zero. Through the last 100 ft. (Fig. 4), the reduction in speed was 18 miles per hour as compared with 2 miles per hour in the last 100 ft. in Fig. 2, and 3 miles per hour in Fig. 3.

Thus is graphically illustrated the difference in the effect of the brakes on the train at different speeds and during different portions of the stop. It should be taken into consideration, also, that the stop was made with the high speed brake, and that the brake shoe pressure during the earlier stages of the stop was higher than toward the finish. If the brake shoe pressure had been the same throughout the stop the speed curve in Figs. 2 and 3 would have been nearer a true horizontal line with less of a tipping

wheels, the truck as a whole is retarded and tends to hold back the engine while the inertia of the engine tends to carry it on by the same amount. This action and reaction necessarily takes place at the center bearing and causes a frictional resistance to turning and is that much of a hindrance to curving.

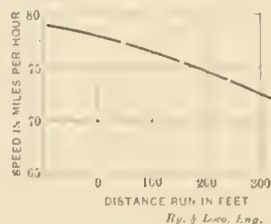

FIG. 2.

This diagram shows the reduction in speed at the commencement of stop of a train running nearly 80 miles per hour to be only about 5 miles per hour at the end of the first 300 feet.

What this amounts to is another question which might be interesting to investigate.

Columbus, O.

W. A. J.

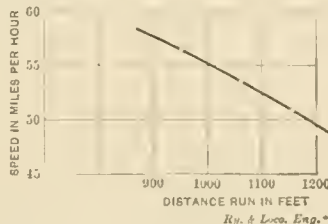

FIG. 3.

This diagram shows the reduction in speed at the middle of stop of a train running nearly 60 miles per hour to be about 9 miles per hour in 300 feet.

[The point is well taken by our correspondent. At the time of brake application, the engine truck is pulling backward on the center casting and the loco-

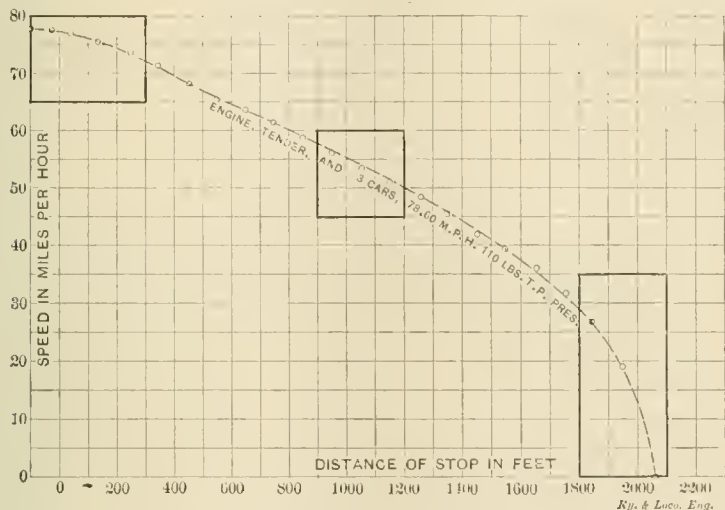

FIG. 1.

BRAKE RETARDATION AT DIFFERENT PERIODS OF THE STOP.

reduced from 58 to 49 miles per hour through the section. The reduction made by the brakes in the speed of the train through the last section, from 1,100 ft. to 1,200 ft. was approximately 3 miles per hour. The work done by the brakes through this section was better than that illustrated in Fig. 2, at the commencement of the stop.

Fig. 4 likewise illustrates that portion of the speed curve taken from the finish of the stop, or that portion lying between the end of the stop and the preceding 300 feet. The line has tipped further downward and fallen from the horizontal direction as the speed progressed, and now, at the finish, is almost perpendicular. It is interesting to note that through the first 100 ft. section, at the beginning of the stop (Fig. 2), the speed curve described a path almost horizontal, while at the finish (Fig. 4), it has tipped almost 90 degrees and ends in almost a perpendicular path. The brakes reached their maximum efficiency at the end of the stop. The train was

tendency, although the direction of the curve at the finish, Fig. 4, would have been practically the same as that in the illustration.

The slow tipping or falling of the speed curve in Fig. 2 shows that the brake is producing less effect on the train than in Figs. 3 and 4. Fig. 3 shows an increase over Fig. 2, as the curve slants downward more than in Fig. 2, but the rapidly increasing slant of the line in Fig. 4 closely approximating the perpendicular, shows that a tremendous amount of braking is being done at the finish of the stop.

CORRESPONDENCE.

Forward Truck Brake a Hindrance to Engine Curving?

In your December number in discussing the engine truck brake as a hindrance to curving, you have overlooked one point.

When brakes are applied to the truck

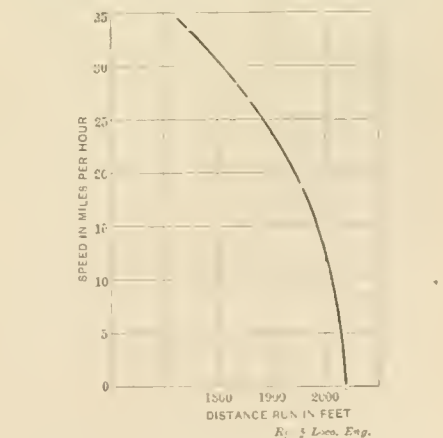

FIG. 4.

This diagram shows that at the finish of the stop of a train whose original speed was nearly 80 miles per hour, the speed was reduced from 33 miles per hour to 0 in the last 300 feet, and from 18 miles per hour to 0 in the last 100 feet.

motive boiler is pushing ahead. The center bearing of the engine is exerting a force directly ahead in its socket in the center plate of the truck. Of course,

there is a certain amount of rotary friction between the forward edge of the center casting of the engine and the reacting forward flange of the center bearing of the truck which offers a slight hindrance to the curving of the truck, but this is quite inconsiderable, providing the frictional parts are lubricated sufficiently to permit a free turning of the center casting of the engine in the center bearing of the truck. However, if the lubricant is lacking, or the center casting is too snugly fitted in the center bearing, the truck may refuse to obey the influence of the rail to turn the truck from a straight line. This is a fact which has been demonstrated on locomotives not having engine truck brakes. We have one case in mind where the forward truck climbed the rail, due to too tight a fit of the center casting in the center plate bearing. We believe this to probably be the cause of the forward truck of locomotives climbing the rail and not to the slight frictional resistance caused by the center casting pushing forward against the center bearing of the truck. However, our correspondent's point is well taken and is an interesting one.—Ed.]

A Duplex Air Pump.

I send you herewith a sectional view of a compound air pump, which was illustrated in your journal some months ago, and at that time had not been tested as to its economy and efficiency. As I have had the pump tested by a competent pneumatic engineer in the presence of air pump experts, I thought the readers of your journal might be pleased to know the results.

For the benefit of those who did not see the previous illustration, I append the following brief description of its construction and operation. It is a twin, Westinghouse eight inch pump, and all parts are interchangeable with same, excepting the top head, steam cylinders, center piece, and air cylinders, which are cast double. Both steam cylinders are eight by nine. Both air cylinders are seven and one-half by nine. The left side is the live steam part, and the right side is operated by the exhaust steam from same. The air from the right air cylinder is delivered to the left air cylinder at its center, through port 37.

The cut shows the live steam piston at the top of its stroke with valves in position to exhaust steam into the bottom end of the low pressure cylinder. This will move the double ended poppet valve upward, and close the bottom exhaust port 29, and open the top exhaust port 29, and at the same time force piston 24 to the top end of its cylinder past the top exhaust port, allowing all the steam from both high and low

pressure cylinders to escape to the atmosphere through port 30. The parts will remain in that position until acted upon by an exhaust from the opposite direction, which will repeat the operation. The low pressure piston cushions on the air left in the ends of its cylinder beyond the exhaust ports, which escapes through the small ports leading to the poppet valves which are filed flat on four opposite sides to allow it to

QUESTIONS AND ANSWERS

ON AIR BRAKE SUBJECTS.

(1) G. T., Battle Creek, Mich., asks:

Why does a cut-out cock under a car have the handle turned at right angles to the pipe when cut in, and parallel with the pipe when cut out? A.—This is an old custom and, possibly, not the best, established in the

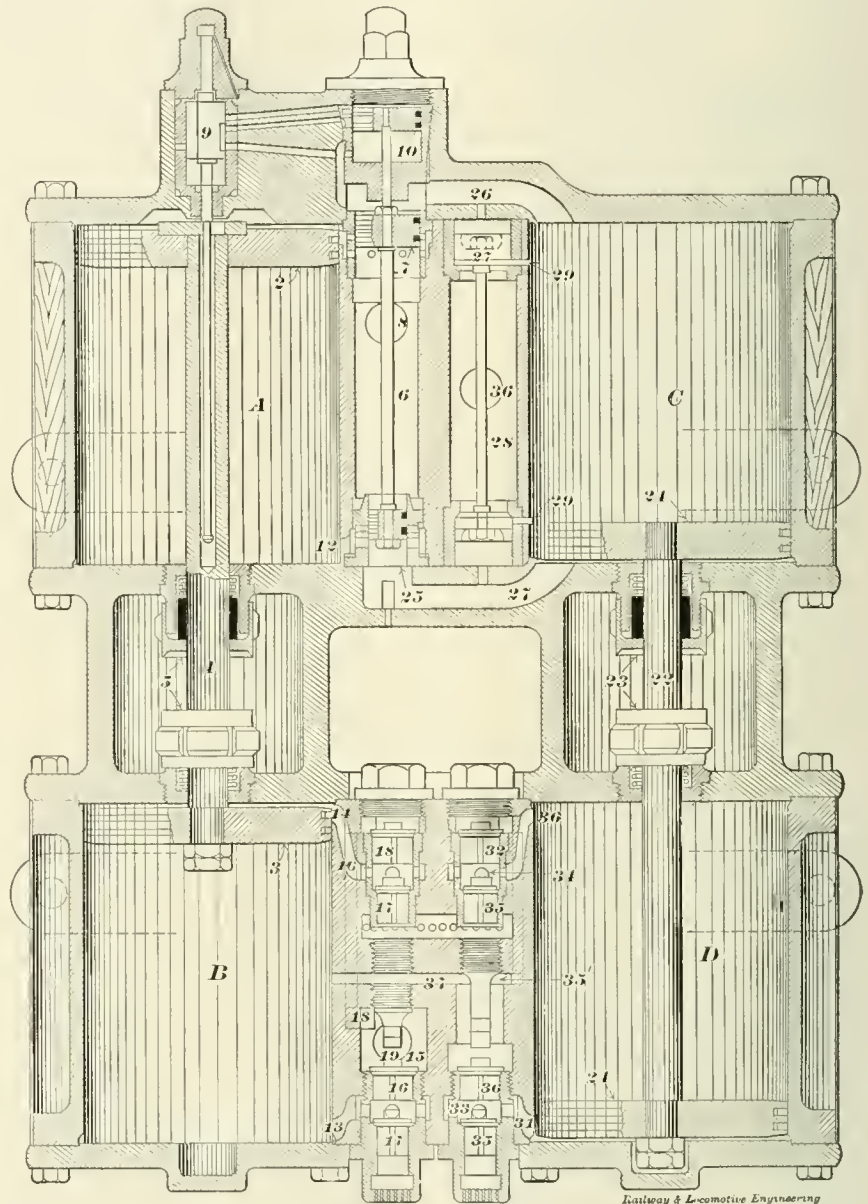

MARSH'S COMPOUND AIR PUMP.

pass to the exhaust. The above action of the low pressure piston takes place before the high pressure piston moves half stroke, and therefore delivers the contents of its cylinder to the high pressure cylinder before its piston passes port 37, thereby doubling the amount of free air compressed at each stroke of the pump, which saves one-half of the steam used by a single pump.

G. W. MARSH.

Oakland, Cal.

early days of the air brake, and is just opposite to the practice of plumbers and steam fitters, whose rule is to have the handle of the cock parallel with the pipe when the passageway through the cock is open, and crosswise of the pipe, or right angles to it, when the passageway is closed.

(2) B. McC., Louisville, Ky., asks:

Which parts of the 8 in. and 9½ in. air pumps are most likely to break and give out, causing a break down? A.—In the

An Engineer's Pride

There's many a Knight of the "Iron-Horse" that feels the pride of a Father in the good working and unbroken record of his locomotive. He cares not so much for saving coal and oil for a big corporation as he does for the good of his personal record. It's this careful pride in his engine's work that makes him a valuable engineer to his company.

Dixon's Flake Graphite has figured in the best performances of locomotives for several years. It will keep pins, journals and eccentrics cool throughout the longest, hardest runs with the smallest amounts of ordinary oil. It will stop the laboring of valves and gear and the groaning and cutting of pistons. Here, there and everywhere applied, its magic influence is immediately felt in greater power and reduced friction.

Coal and oil consumption drops surprisingly, longer trains pull with ease, grades are apparently leveled, and unscheduled stops cease.

Engineers who have pride in their engines usually treat them to Dixon's Pure Flake Graphite.

Booklet 69c and sample upon request to any interested person.

**JOSEPH DIXON
CRUCIBLE CO.
Jersey City, N. J.**

8 in. pump the reversing valve rod sometimes breaks, and the reversing plate sometimes wears badly or breaks from its fastenings on the steam piston. The reversing piston rod may also break from its head. The lock nuts on the lower end of the piston rod sometimes break off, and sometimes the main valve packing rings wear the bushing so badly as to require renewal. This latter is a very common cause of the pump "dancing." The 9½ in. pump sometimes breaks its reversing valve rod, and infrequently the lock nuts on the lower end of the piston rod become loose and jamb. The air valves sometimes break in both pumps, and, with bad usage the steam piston may break from the rod.

(3) C. D. H., Seattle, Wash., writes:

Was not the first retaining valves used on the western roads, and was it not then built with a rubber diaphragm and spring instead of a weighted valve? A.—The first retaining valves used were on the Denver & Rio Grande, and were of a type employing tempered sheet brass diaphragms and a spring. The late H. C. Frazer, of the Westinghouse Air Brake Co., made quite extensive experiments with these valves, and the outcome was that the weighted valve replaced the earlier type, as being more reliable and easier maintained under practical road conditions.

(4) S. J. E., Wilkesbarre, Pa., writes:

On an engine equipped with the combined straight air and automatic brake, suppose you were coming down a heavy grade, and should want to let off your driver brake (set in the automatic) so your driving wheel tires could cool off, if they were heating. How would you do it without letting off your train brakes? A.—This could not be done with the ordinary arrangement of the combined straight and automatic brake. However, engines in grade service are often fitted with a special pipe, tapped into the driver brake cylinders or connections, and run up into the cab, near the engineer's seat box, where a stop cock is placed on the other end of the pipe. With this arrangement the engineer can release the driver brakes without relasing the train brakes.

(5) H. A. J., Chicago, Ill., writes:

Last week I cleaned and overhauled my pump governor, and after I got through with it I replaced it again, and adjusted it to maintain the main reservoir pressure of 90 lbs., and it worked all right for about five hours, when, all at once, I noticed that steam was blowing out of the drip pipe, and also air blowing out at the relief port. *c*. I tightened the nut, *40*, just a little, and that stopped it, but after five days it did the same thing again. I let it alone

that time, and it stopped itself, and now it is all right again. Will you please state what is the matter with the governor? The pump supplies my testing apparatus where I test triple valves. A.—Probably the air pressure blowing out of the port *c* is due to the pump accumulating its governor pressure. If steam passes out at the waste pipe, it is probably due to the wear of the piston stem, which permits steam to come from the lower part of the governor body up under the piston, and thence out through the drain pipe. In tightening down the nut, *40*, you probably squeezed some dirt under the diaphragm valve, which softened and broke, thus permitting the valve to seat.

(6) O. E. C., Oil City, Pa., writes:

What makes a brake apply and release alternately with the brake valve handle in the running position? The pressure will drop on the black hand of the gauge 2 or about 3 lbs., the brake will set, and all of a sudden the black hand will start to rise, and the brake will release. This operation will repeat itself a number of times, although there is nobody around the engine. A.—Probably the piston in the feed valve attachment is a too tight fit, holding the slide valve in position covering the feed port. The train pipe pressure leaks down, but the sticking piston holds in its position. After 2 or 3 lbs. have been reduced by leakage, the preponderance of pressure on the slide valve side of the piston will cause the piston and slide valve to move, opening the feed port, and the brake releases. After the train pipe pressure closes the diaphragm valve, the feed valve will probably remain open until the train pipe is overcharged a pound or two and then close. This may be repeated several times. By removing the piston and slide valve, and cleaning them, using a very small quantity of light oil on the piston and a more liberal quantity of heavier oil on the slide valve, before returning them, the trouble will usually disappear.

(7) J. L. E., Reading, Pa., writes:

Which is the proper way to release the Straight Air Brake on a switch engine? Should the handle of the straight air valve be placed in full release a little while, and then drawn back to the notch in the middle of the quadrant, as with the Automatic Brake, or should the handle be left in full release a longer time? A.—Experience should answer such a question in short order. In releasing the Straight Air Brake on an engine and tender equipped with the Combined Automatic Straight Air Brake, the brake valve handle should be thrown to the extreme release position and left there until it is desired to again apply the brake. In applying the

brake, the handle should be drawn past the lap position, into application position, and after a desired amount of pressure has been passed to the brake cylinder, the brake handle may be moved to lap to hold the brake on that amount. Upon releasing, however, if it is desired to release only a portion of the air from the brake cylinder, the handle should be placed in release position long enough to release this amount, then brought to the lap position. This may be repeated as often as desired to release the brake gradually or a little at a time. If it is desired to release the brake entirely, the handle should be left in full release position, and not brought back to the lap notch.

(8) E. V. C., Syracuse, N. Y., writes:

Is it not a waste of air to operate high-speed brakes? From the moment the automatic reducing valve opens in making an emergency stop until it closes, there is a large quantity of air wasted by the reducing valve blowing down. It is the same as a bad leak in the brake cylinder. Would you not consider it a bad waste of air to use the high-speed brake? A.—The air is not wasted which blows out of the reducing valve, during the time of stop, as the air has performed its duty by giving higher pressure to the brake shoes, momentarily, and is then exhausted, in the same manner that any air is released after having performed its work. The amount of air blown away by the reducing valve during the stop, has performed the work of bringing the train from a very high speed, where danger from wheel sliding is absent, down to a moderate speed, where sliding might be expected if the pressure was held, and then having finished its work during the various stages, it is exhausted to the atmosphere. The amount of air afterward remaining in the brake cylinder has also its work to perform; that is, to hold the brake shoes as tightly against the wheels as is safe, to the end of the stop, and then it is released. Therefore, it cannot be said that air is wasted when it blows from the automatic reducing valve, any more than it can be said that air released at the triple valve, after the brake has stopped the train, is a waste.

The Oldest Locomotive Engineer.

William Best, of Alanthus, Gentry county, Mo., aged 92, has applied to the department of transportation at the World's Fair, asking to be placed in charge of the "first locomotive," which will be shown in the historical exhibit of the Baltimore & Ohio Railroad. Mr. Best claims that he was engineer of one of the first locomotives operated in the United States on its run of 30 miles from Philadelphia to Trenton in 1833.

Quick-Sight Utica Steam Gauge.

The Utica Steam Gauge Company, of 123 Liberty street, New York, have put upon the market what they call a "Quick-Sight" locomotive steam gauge. The face of the gauge is black with heavy block figures stamped in the dial and colored with pure silver. They stand out boldly and can be seen and read at considerable distance. The pointer of the gauge is of aluminum color from the center to the top, the lower half of the pointer being obscured by being painted the same color as the dial. There is no mistaking the reading shown by this dial for all you can see is the hand from the center up, pointing to the figure indicating the steam pressure.

The gauge is "vertical reading" also; that is, the popping pressure can always be shown by the vertical position of the pointer. The dial can be shifted and secured by a little screw which passes through one of a number of small perforations in the circumference of the dial made for this purpose. This also enables the gauge to be connected at an angle as some gauges have to be, and it can be changed from one engine to another, and the dial can be set so as to give the desired vertical reading every time.

Lastly, there is the non-shadowing gauge rim. This is made of brass and stands up about an eighth of an inch from the glass and then falls away below the level. As it has no overhang, it enables one to read the gauge from any place where the gauge can be seen.

The back flange of the gauge is made with a series of lugs cast on, which provides for an air space at the back of the gauge, and obviates the chance of losing the flange rings usually supplied with gauges.

New Barrett Geared Ratchet Lever Jack.

The Jack made by the Duff Manufacturing Company, of Pittsburgh, Pa., is designated as the No. 30 Barrett Jack, and has many features which will commend it to those having heavy loads to be raised quickly and easily. It is made of refined malleable iron and steel throughout, and is operated in the same manner as the No. 19 Barrett Jack. The jack is single acting and automatic lowering. The lifting bar or rack is of high grade open hearth steel, and is raised by a machine cut steel pinion. This pinion is integral with a large steel gear having ratchet teeth on its circumference. The gear is rotated by means of a socket lever and pawl, and the retaining pawl, together with the automatic lowering device is the same as is used in the No. 19 Barrett Single Acting Automatic Lowering Jack. The method of rotating the gear by a socket

GOLD CAR HEATING AND LIGHTING COMPANY

Catalogues and Circulars Cheerfully Furnished

MAIN OFFICE
FRANKFORT AND CLIFF STREETS
NEW YORK

BRANCH OFFICE
THE ROOKERY
CHICAGO

Manufacturers of ELECTRIC, STEAM AND HOT WATER APPARATUS FOR RAILWAY CARS



“Throw away your Glue Pot”

Why have the smell of boiling Glue around you all day, and the waste and expense of boiling dry Glue, when you can for less money use

ARMY & NAVY LIQUID GLUE?

Not a Fish Glue but a pure hide and sinew glue in liquid form.

The Glue of the 20th Century

will do twenty-five per cent. more work than a fish glue.

No smell. No dirt. Always ready for use.

Let us send you Samples and Prices

WACHTER MFG. CO.
BALTIMORE, MARYLAND

lever and pawl requires no special care on the part of the operator. The method of operation is simply raising and lowering the socket lever. This new Barrett Jack is an improved quick acting jack, for the rapid handling of heavy loads. It has the simplicity of an ordinary lever jack, the leverage being especially compounded to permit ease of operation and quick action. The jack has no complicated features and cannot easily

be laid in changing bearings on the road. There is also a great deal of unnecessary time and labor spent in repair yards in changing bearings.

The device here illustrated is designed to reduce the time and labor in changing bearings both on the road and in yards. It is claimed that one man with any good journal box jack and with this Handy Journal Box Jack Block can change bearings in from five to ten min-

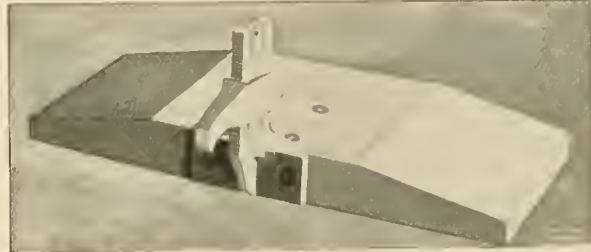

THE HANDY JACK BLOCK WITH WHEEL HOLDING ATTACHMENT.

get out of order. There are several important features of this jack which are covered by patents. Write to the Duff Manufacturing Company for information concerning Barrett Geared Ratchet Lever Jacks, if you are interested.

The Handy Journal Box Jack Block.

The removal of journal bearings and wedges and the insertion of new ones is a simple operation; it sometimes becomes difficult because of the raising of

utes. The device consists of a base or block of oak, 9 ins. by 2½ ins. by 26 ins., which rests on the ties or ballast and on which the journal box jack rests. On the inner edge of the block is secured a malleable casting, this casting having top and bottom flanges for securing it to the block by bolts and rivets, on this casting there is a post having teeth on the edge next to the wheel, moving loosely on this post is the hook-like piece, also of malleable iron, having teeth for engaging with the teeth on the

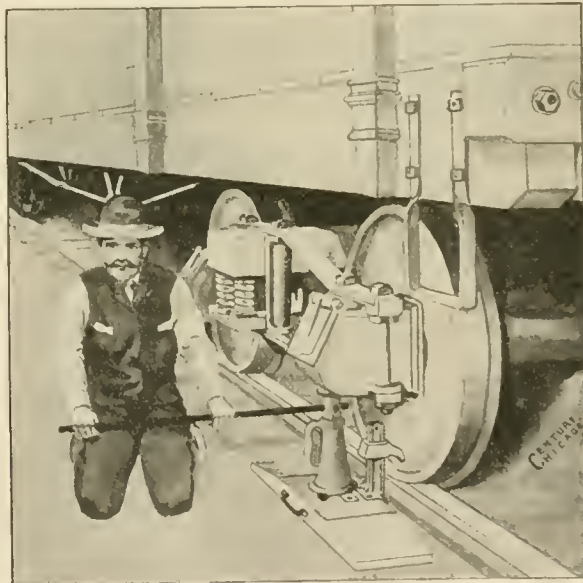

THE HANDY JACK BLOCK EQUIPMENT.

the wheel when the load is lifted by the jack under the journal box. The result of this lifting of the wheel is that the bearing and wedge do not become free so that they can be taken out. The usual procedure under these circumstances is to get two men to assist the man with the jack; bars and levers being required to hold the wheel down so that the hot or worn bearing will come out and that no time be lost in inserting the new bearing. Many trains are de-

post; the hook is thus kept from slipping upwards when the strain is applied in resisting the tendency of the wheel to lift. The projecting hook or arm engages the rim of the wheel. Adjustment for varying heights is provided by the provision for locating the hook at different positions on the post. A handle for carrying the device by is provided. The address of the Handy Car Equipment Company is 890 Old Colony Building, Chicago, Ill.

The Union Switch and Signal Company, of Swissvale, Pa., have issued another of their series of illustrated catalogues, Section 14, Relays. This gives cuts and descriptions of the various kinds of relays which are made by this company, viz., the polarized and the neutral types; among the latter may be mentioned seven kinds. The polarized relay is a very ingenious piece of electrical mechanism. It is used in connection with the "home" and "distant" signals in the block signal system, and when both the signal arms have gone to "danger" and "caution," the polarized relay is able to permit the lowering of the "home" arm at the entrance to the block, while holding the "distant" arm at "caution," while the block next ahead is occupied. If the catalogue would be of any use to you write to the company asking them to send you a copy.

Metal Melting Furnace.

This type of furnace was evolved after considerable experimenting with nearly every type of furnace on the

varies from two to two and one-half gallons of crude oil per hundred pounds of metal melted. The life of the linings is from three to four hundred heats, varying with the kind of metal melted. The whole furnace is of a heavy and substantial construction, and is durable. On account of the simple form of the tile it is very easy to reline.

This furnace is made in two sizes, the No. 1 size having a capacity of five hundred and fifty pounds of metal per heat, and the No. 2 size having a capacity of twelve hundred pounds of metal per heat. This Metal Melting Furnace has been found to be very efficient and economical in melting metals particularly brasses and bronzes. It is made by the Lunkenheimer Company, of Cincinnati, Ohio.

Story of the Flood.

"The Flood of 1903" is the title of a little souvenir book got out by the passenger department of the Chicago &

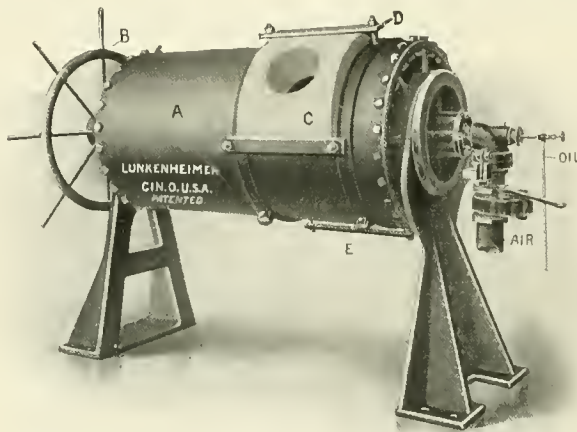

NEW METAL MELTING FURNACE.

market, and is the result of considerable study on this subject. As will be seen from the cut, the furnace consists of a cylindrical sheet-steel drum. The interior of the drum is lined with fireproof tile, and there are two openings on opposite sides of the drum. Only one of these openings is in use, the other being closed by a fire-clay filling. The object of having two openings is to increase the life of the linings of the furnace as a furnace wears out quicker around the filling hole which also deserves an outlet for the flame than it does elsewhere.

The oil burner is of a special type, designed to give the greatest amount of heat with a minimum consumption of oil. These furnaces are able to secure from six to seven heats per working day of ten hours from each furnace. The weight of each heat will average about five hundred and fifty pounds, and the oil consumption

Alton. The book is dedicated to the ticket agents throughout the country, because, we are told, they can especially appreciate the difficulties under which railways are sometimes compelled to operate. We think there are others besides our good friends the ticket agents who can fully appreciate, not exactly what the Alton was "up against," so much as what the Alton "was into" at the time of the flood. One picture taken at Kansas City, on June 2, 1903, showing the high water mark at the Twelfth street viaduct, is one calculated to arouse emotions in the hearts of those in the motive power departments of our railways. The picture shows an engine standing in the flood where only the cab windows and the running board are above the surface and only the coping of the tank shows the position of the tender. This interesting little souvenir contains a brief history of the flood, and more than fifty half tone illustra-

There's a New Edition of Air Brake Catechism

Just issued. By Robert H. Blackall. Entirely rewritten, revised and enlarged. Eighteenth Edition. Contains 1,500 Questions and their Answers on the Westinghouse Air Brake, which are strictly up-to-date. Fully illustrated, besides including two large Westinghouse Air Brake Educational Charts printed in ten different colors. The latest practical work published for the Fireman, Engineer, or practical Railroad man on all matters relating to the Westinghouse Air Brake. Send for a copy and get posted on how to Handle Air Brakes. Sent postpaid on receipt of \$2.00.

23d Edition

Locomotive Catechism

By Robert Grimshaw. Is right up-to-date and contains twelve large Folding Plates and 1,600 Questions and Answers which, if studied by you, will not only assure your promotion but make your future running experience a complete success. The standard book on How to Run a Locomotive. Endorsed by all Railroad Journals as the best book. Price prepaid, \$2.00.

Combustion of Coal and the Prevention of Smoke

By Wm. M. Barr. Contains over 800 Questions and their Answers on How to Make Steam. Every railroad man needs this up-to-date treatise on the Prevention of Smoke. Price, \$1.50.

Locomotive Breakdowns and their Remedies

Just issued. By Geo. L. Fowler. An up-to-date catechism of ready reference, telling how and what to do in case of a breakdown on the road; including special chapters on Compound Engines. Every part of the Locomotive is treated and a remedy given and explained in detail. Better procure a copy so you will be able to cope with any accident or breakdown. Price prepaid, \$1.50.

These books contain the Questions and their Answers asked by the examiner on your road, so don't put off until examination day comes, but get them now.

Send for a special circular describing the books in full. Any book sent prepaid on receipt of price.

Agents Wanted. Good Pay. Write for Particulars.

The Norman W. Henley Publishing Co.
132 Nassau St. New York, U. S. A.

Ball's Official R. R. Standard Watches

16 AND 18 SIZE.



17 AND 21 RUBY JEWELS. SAPPHIRE PALLETS

BALL'S IMPROVED SAFETY DOUBLE ROLLER

Are without question the finest watches that American talent and skilled labor can produce, and they are giving such universal satisfaction that we have no hesitancy in claiming that they are the best and safest railroad watch on the market.

Tests severe and numerous have proven this fact to the most critical users in all sections of the country, to which thousands of good Railroad and Brotherhood men are ready to certify.

We have an authorized agent in nearly every railroad center. Call on him for information and facts. Write us for descriptive matter.

The Webb C. Ball Watch Co.

Watch Manufacturers

Ball Building, Cleveland, Ohio, U. S. A.



FINISHED WORK

Above cut shows finished work of

HOSE REPAIR OUTFIT

This outfit will do anything in the way of repairing **Steam, Signal or Air Brake Hose**, strip, cut, splice and fit up. Also fits up new hose.

Will pay for itself on most any railroad in a year and many times over on some roads.

Shall we tell you more about it?

BUKER & CARR MFG. Co.

Office, Fairview Heights, No. 19
ROCHESTER, N. Y., U. S. A.

tions showing how Kansas City temporarily rivaled Venice. If you want a copy of this very interesting souvenir write for one to Mr. Geo. J. Charlton, general passenger agent, Chicago.—"It's the only way."

Unique Tool Holder.

A unique tool holder is in use in the Missouri Pacific Railway shops at St. Louis. It was invented by Mr. F. W. Roebbel, who is in charge of the company's tool room at that point.

The device which we here illustrate has given every satisfaction in service. The body of the holder is made of soft steel, while the clamp, which fits into the body and secures the tool in position, is made of tool steel. There are no set screws used to hold the actual cutting tool, the whole device is held securely by the set screw in the ordinary tool post. The tool holder resting on a parallel washer the tool can be raised and lowered for the required height, and thus retain the proper clearance and the proper rake. The tool itself needs grinding only on the top. The holder has been used in

ton and Water streets, Buffalo, N. Y., if you are interested in steam hammers.

"Clear Tracks with Norton Jacks" is the catch phrase on the outside of a small folder got out by A. O. Norton, 286 Congress street, Boston, Mass. This jack has no valves or packing, no alcohol or filling, it is always ready for use, as the working parts are thoroughly protected from grit and rust. Mr. Norton has a branch establishment at Coaticoke, in the Province of Quebec, Canada. In the folder, in connection with the catch phrase referred to, he uses the appropriate representation of a railroad track with a semaphore signal with its arm in the "all clear" position. The jacks are the well known ball bearing ratchet screw jacks and the "sure drop" jacks. Write to Mr. Norton for information, if you are interested.

The Baldwin Locomotive Works have issued a very neat publication of uniform size with their Record of Recent Construction. It is concerned with Light

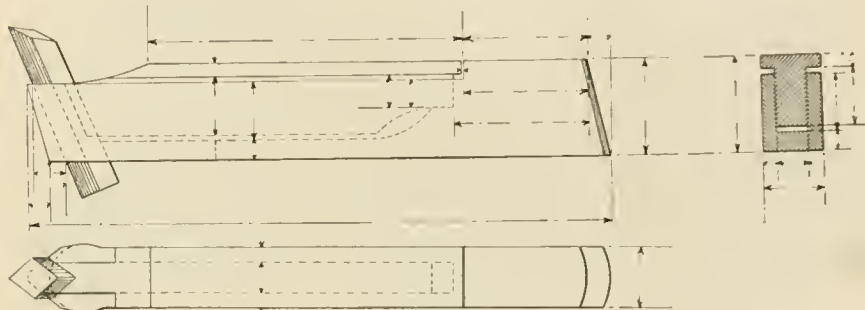

UNIQUE TOOL HOLDER.

the Missouri Pacific shop on all kinds of work, including heavy cutting, such as tire turning, and a saving in tool steel has been effected. Mr. Roebbel has made application for a patent on the device.

The David Bell Engineering Works of Buffalo, have issued a neat, red covered catalogue dealing with Bell steam hammers. There are half-tone illustrations and data concerning each printed below. The introduction deals with the features of construction and gives some general information concerning "Regular Bell" hammers. Under the head of general directions the method of building a proper foundation is taken up and cuts with table of timbers for all sizes of hammers are reproduced. This information is given first concerning comparatively light hammers and later on is given in connection with hammers from 300 lbs. up to those of 1,600 lbs. When a hammer is spoken of as a 1,600 pound hammer it means that the weight of the falling parts is 1,600 lbs. in weight. Write to the Bell people. Evans, Nor-

Locomotives, and among other things gives the Baldwin method of class designation, and the formulas for determining resistance of locomotive and train due to grade, curves and speed. The tractive power of single expansion locomotives is given, also a chart of the reduction of mean effective pressure and a table and formula of the horse power of an engine. There is also a table of the amount of tons of rails of various weights required to lay one mile of track and some miscellaneous information concerning logging and plantation, industrial, contractors' coke oven and mine service. There follows a series of illustrations of light locomotives with sizes, gauge of track, weight, etc. The half-tones are excellent, and the whole work is a good example of the printers' art.

Any man may be in good spirits and good temper when he's well dressed. There ain't much credit in that. If I was very ragged and very jolly, then I should begin to feel I'd gained a point.—*Martin Chuzzlewit.*

Niles-Bement-Pond Quartering Machine.

The illustration shown, is an 85-in. Quartering Machine, driven by direct-connected motor, and made by the Niles-Bement-Pond Company. It is arranged for quartering and boring crank pin holes in locomotive driving wheels having either right hand or left hand lead. The heads are adjustable for different lengths of axles and the saddle slides are graduated for easy adjustment of boring spindles to the desired length of the stroke. The spindles have power feed and rapid hand movement in either direction. The axles are held on centers and have adjustable V-bearings to which the wheels are securely clamped. The motors are geared to the spindles through Renold silent chains. For changing from right to left-hand quartering, the heads are flopped over to the other side of the

James C. McKee of Cleveland, Ohio, who controls most of the patents used in the manufacture of steel cars, is in Minneapolis looking into the proposition of establishing shops for the manufacture of these goods. It is understood that the Commercial club has agreed to furnish a site of thirty acres for the plant, the erection of which will cost in the neighborhood of \$375,000.

The machinists employed in the Erie Railroad Company's extensive locomotive shops at Susquehanna, to the number of several hundred, went on strike one day last month. The chief contention of the men is that a new foreman has established a too close espionage upon them while they are working. That is a new kind of grievance.

In the annual report of the Clerk of the United States Senate an item appears

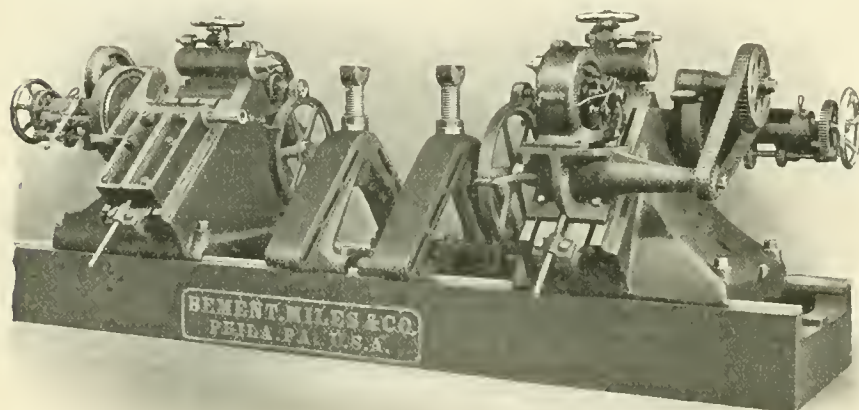

1202

QUARTERING MACHINE—NILES-BEMENT-POND CO.

machine, and the motor base is also turned over and put on the other side of the machine. This affords an exceedingly simple and efficient method of driving.

The Cleveland Twist Drill Company, of Cleveland, Ohio, have issued a very handy calendar for 1904. It consists of a card upon which is mounted in book form, the calendar. Every two weeks is represented by two pages, upon which memorandums can be written down, and the "book" is kept open by two clasps which are fastened to the card at each side. There are a few pages for addresses at the front and a few pages for cash entries at the back. A map of the United States is given, and a list of the principal cities with the population as made up by the census of 1900. The Cleveland Twist Drill people, whose New York address is 62 Reade street, will be happy to send one of their useful calendars to anyone who will write to them for one.

giving the expense incurred for the purchase of morocco pocketbooks for holding railroad annual passes. It is a case of railroad companies furnishing the transportation and the country the pocketbooks.

The Homestead Valve Manufacturing Company, of Pittsburgh, Pa., have issued a small catalogue which gives descriptions and sizes of the Homestead Straightway valve, which is practically a plug valve, which is, when closed, forced firmly to its seat by the operation of a traveling cam. When it is desired to open the valve the motion of the plug in that direction releases the cam and the plug becomes free and easily moved. The Homestead three-way and Homestead four-way valves, Homestead locomotive blow off valve, the Junior valve, the locking valve, the angle valve, are all catalogued. The company announce that they have installed a complete iron foundry in conjunction with their brass

H. S. PETERS'
BROTHERHOOD TRADE MARK **OVERALLS**

have gone to almost every part of the World where Overalls are worn and are everywhere conceded to be the **BEST**. Every point of material, cut, construction and finish is carefully looked after; the only way that superiority can be attained. Every garment is absolutely guaranteed. The Patented, Fleece-lined, Safety Watch Pocket is alone worth a whole suit of any other make.

I'll send sample suits, charges paid, to any place in the World where mail or express goes, where I have no retail agency; sample materials and full particulars for the asking.

UNION MADE
OF COURSE —
B.L.F. 3—H.S. PETERS—B.L.F. 171
DOVER, NEW JERSEY, U. S. A.

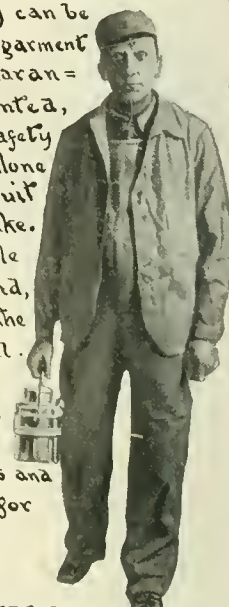

The Twentieth Century Master Mechanic

Won't use solid Mandrels. Cost too much, take up too much room and don't give satisfaction.

Nicholson Expanding Mandrels

Take everything from 1 to 7 inch holes. Take up little room—always ready and you can buy four sets for the cost of one of the solid kind.

Are You Using Them?

Catalogue tells you more about them.

W. H. Nicholson & Co.
Wilkesbarre, Pa.

**MECHANICAL TUBES
BOILER TUBES
WIRE ROPE
RIVETS
TIE PLATES**

MECHANICAL TUBES

Cold Drawn Seamless

BOILER TUBES

Cold Drawn Seamless
Lapweld Charcoal Iron

WIRE ROPE

Bright and Galvanized
Switching and Wrecking
Ropes

RIVETS

Boiler, Tank and Structural
Rivets of Mild Open
Hearth Steel

TIE PLATES

The Hart Tie Plate

CAN'T WE INTEREST YOU?

Miller, Thornburgh & Co.

135 Broadway, New York, N. Y.

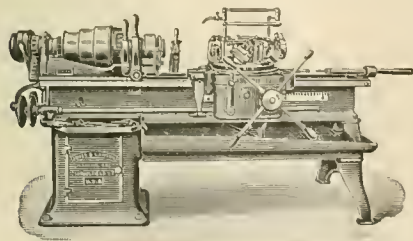

JONES & LAMSON MACHINE CO.

Main Office and Works:

SPRINGFIELD, VERMONT, U. S. A.

A, B, C and Liaber's Code used.

British Office: Jubilee Buildings, 97 Queen Victoria St., London, E. C. France and Spain: Ph. Bonvillain, 6, Rue Blanche, 6, Paris, France. Germany, Belgium, Holland, Switzerland and Austria-Hungary, M. Koyemann, Charlottenstrasse 112, Dusseldorf, Germany.

foundry for the production of both brass and iron, through the use of converting furnaces, in which a heavy blast is used. The process resulting in better metal than crucible or cupola furnaces produce.

Cincinnati Shaper Company's Crank Shaper.

Our engraving shows one of the Cincinnati Shaper Company's 24-in. B. G. Crank Shapers, driven by a Westinghouse type S variable speed motor. This is also for two-voltage, three-wire system, and the motor develops 2 and 4 h.p. at 115 and 230 volts respectively. The connection of the motor to the shaper is through the Reynolds silent chain, and is clearly shown in the photograph. On this machine the 4-step cone is left off, and the sprocket wheel for the silent chain attached to the cone shaft. The machine is our regular 24-in. B. G. Shaper, with automatic power down feed and with table support attached.

The Crosby Steam Gauge & Valve Company, of Boston, have recently got

of the pencil mechanism. Any motion of the piston due to the movements of the spring which may cause the spring rod to deviate in any way from the true line of up and down movement, will not effect the vertical motion of the pencil. The form of the piston has the additional advantage of tending to reduce friction in the cylinder of the indicator. The Crosby people will be happy to give any information or forward pamphlet concerning this indicator to any one who is sufficiently interested to write to them.

A Honeymoon Car.

The Kursk-Zarkoff Railway, in Russia, is reported as advertising a special car for "honeymooners," which is designed and furnished with the very latest luxuries. An engineer and an architect planned it, the decorations are in the best style, and polite female attendants look after the comfort of the happy couples who travel. None but the newly wed are allowed to use this car, which is ingeniously built to ac-

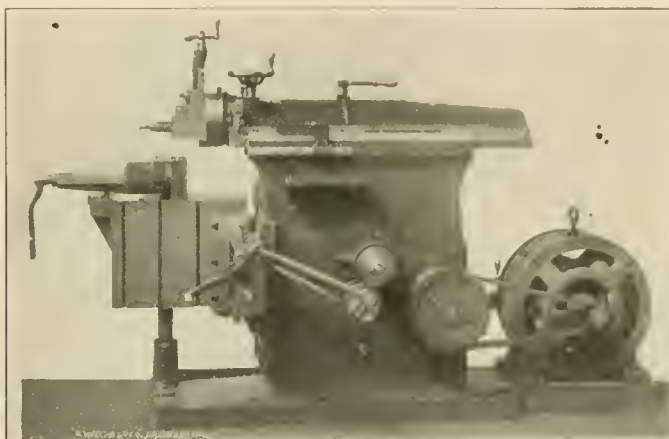

CINCINNATI SHAPER COMPANY'S CRANK SHAPER.

out a new form of indicator which is a departure from the usual form of this instrument. The most striking feature of the new Crosby indicator is the fact that the spring is placed outside on a stand above the moving parts, where it remains cool under all conditions of use. Whatever error arises from heat, therefore, is not present in this instrument. The spring is easy to get at and its being always cool permits of its being replaced without discomfort to the operator. Another new feature of this indicator is in the size and shape of the piston. This piston has an area of 1 sq. in. and is in form the central zone of a sphere. The piston is practically a universal joint and adjusts itself to the torsional strains of the spring when operating the pencil mechanism. The pencil mechanism is attached to a rod which is connected to the piston by a ball and socket joint. This rod slides through a sleeve attached to the base

commodate the very wealthy and also those with a modest purse. The partitions are removable and the car can be used as a series of small compartments or it may be turned into a couple of roomy salons.

The Asheroft Manufacturing Company, the Hancock Inspirator Company, the Hayden & Derby Manufacturing Company, and the Consolidated Safety Valve Company, all of New York, have on account of the large increase of business, arranged to establish a western branch office and salesrooms at Nos. 22, 24 and 26 South Canal Street, Chicago, Ill. The office will be in charge of Mr. H. S. Whitney and Mr. A. M. Hudson, and the companies interested invite their friends and customers to call at the new western office where complete lines of the various specialties manufactured are kept in stock ready for immediate delivery.

Eberhardt's Extension Base Shaper.

The annexed engraving illustrates the 24x26-inch extension base shaper fitted with direct-connected variable-speed electric motor drive, recently put on the market by Gould & Eberhardt, of Newark, N. J. This tool is one of the most complete equipments of the kind that has ever been put on the market. The variations in speed are instantly obtained by turning the round rheostat knob shown mounted on the panel at the top of the shaper and it can be worked from 5 to 100 strokes per minute. The machine is also fitted with a particularly efficient clutch and brake arrangement controlled by a long lever which enables the operator to instantly stop the shaper at any point of the stroke without stopping the motor and waiting for it to run down. It also saves time in starting up, in not having to

riveting together the steel members of a skyscraper. A model of the axle valve fastened at the pivot by an ilel allows a small tag or tab to swing round and point to each column representing a week. The monthly calendar sheets are arranged radially so that by moving the pointer every twenty-four hours the particular day of the month will be somewhere on the radial week column represented. Write the company for a calendar, if you are interested.

The Smooth-On Manufacturing Company, of 572 Communipaw avenue, Jersey City, N. J., have issued a very serviceable calendar for the year of grace 1904. The figures are large and clear, the Sundays and holidays being printed in red ink and the rest in black. If you want to get smoothly on to the day of the month get a Smooth-On

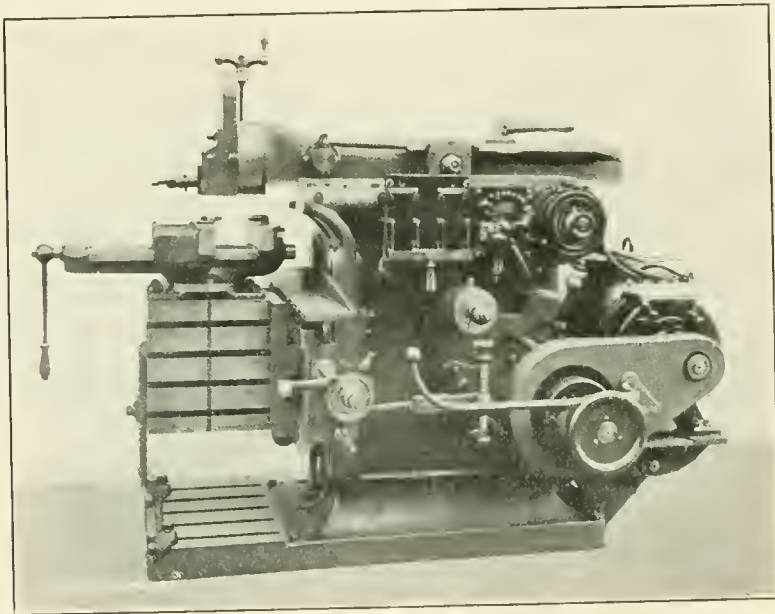

GOULD & EBERHARDT SHAPER

wait for the motor to get up speed again. All controlling handles operate while standing in the working position at the front of the machine. The shaper itself is of a re-designed pattern, which has been strengthened and made more powerful, so as to obtain the fullest benefits from the new "high-duty" cutting steels. The Pennsylvania Railroad Company ordered fourteen of these machines for use in their new shops and subsequently increased the order to eighteen. This shaper is very popular in locomotive-building shops and quite a number of them have been purchased for the various works.

The Ingersoll-Sergeant Drill Company, of 26 Cortlandt street, New York, have got out a very pleasing calendar for 1904. It shows an ironworker using a patented Haeseler axle valve hammer,

calendar. And the way to do this is to write the Smooth-On Company for a calendar. Are you on?

The Pullman Company has ceased building compartment sleeping cars and the railroads are gradually stopping using them. The passing of the compartment car was made an assured fact recently, when all the Chicago-St. Louis lines entered into an agreement to cease their use. Soon after that other railroads signified their intention of doing away with them as fast as possible and the Pullman Company will not construct any more cars of this type. The reason for the move is not to be found in lack of popularity with the public, but in the tremendously increased travel. The compartment car weighs nearly ten tons more than the standard Pullman, and will not carry as many passengers.

Keep Your Mind On It

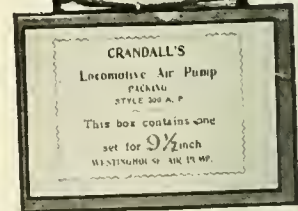

CRANDALL'S
Locomotive Air Pump
PACKING
STYLE 300 A. P.
This box contains one
set for 9 1/2 inch
WESTINGHOUSE AIR P.M.P.

CRANDALL'S HELIOS AIR PUMP and THROTTLE VALVE PACKING

Put Up in Sets
Exact Fit to Rod and Box
Send Trial Order

The Crandall Pkg. Co.
123 Liberty Street
N. Y. CITY

Chicago Office, 30 La Salle St.



**Over One
Thousand
Miles
A DAY**
on

"The Colorado Special"

Dinner in Chicago Today
Breakfast in Omaha Tomorrow Morning
Dinner in Denver Tomorrow Evening

**SPLENDID TRAIN SERVICE
to DENVER via UNION PACIFIC**

Full Information cheerfully
furnished on application to
G. P. and Tkt. Agt.,
Omaha, Neb.

Computers

Train Resistance Computer and Locomotive Tractive-Power Computer

Each Computer is in a neat folding, leather-covered case. One side gives formula and directions for use. The other side has a graduated circle upon which turns a graduated card disc.

Can be Adjusted in a Moment to Give Result Without Calculation

Price, \$1.00 Each

The

Compound Locomotive

ONLY BOOK FOR ENGINEERS AND MOTIVE POWER MEN.

Flexible Leather, - - - \$1.00
THIS OFFICE

The Union Switch & Signal Co.

OF PITTSBURGH, PA.

GENERAL OFFICES AND WORKS AT SWISSVALE, PA.

DISTRICT OFFICES:

New York: Central Building, 143 Liberty Street.

Chicago: 1536 Monadnock Building.

St. Louis: Terminal Station.



Better Belt Service

Cling-Surface is a filler and preservative for belts, making and keeping them pliable, elastic, waterproof, preserved.

It stops slipping entirely, allowing all belts to run easy under fullest loads.

It is not a sticky belt dressing. Used by Pa. R. R., D. L. & W., P. & R., D. & H., Iowa Cent., N. Pacific, A. T. & S. F., American, Rogers, H. K. Porter Locomotive Cos.; American Car Co., Carnegie and Westinghouse Cos., and many others.

Order on approval. We guarantee it. Ask for book, "New Knowledge on Belt Management."

Cling-Surface Mfg. Co.
Virginia Street Buffalo N. Y.
Branches in leading cities

Engines and Cars Built in 1903.

During the year of grace 1903, there were 5,152 locomotives built in the United States, and this is 1,082 engines in excess of 1902, which makes a very substantial increase. It is the largest which has ever before been recorded, but the explanation offered is that a good many of these were on orders placed in 1902, but which were unavoidably held over. Among the 5,152 locomotives, 88 were for electric traction.

The output of cars from all the car building concerns in the country for 1903 amounted to 154,808. These figures include all freight and passenger cars built for steam and electric roads, but do not include any built by railway companies at their own shops. Dividing the total output approximately into passenger and freight cars, the "varnished cars" were about 2,007, while the freight amounted to about 152,801. Among the freight cars, 1,613 were for export and 153,195 were for domestic use. It would be interesting to compare these figures with the total number of cars destroyed in accidents or taken out of service each year if accurate data was at hand.

New Baker Heater.

To meet a constantly growing demand from railway companies all over the country for a smaller and cheaper steel heater, the well-known firm of William C. Baker, 143 Liberty street, New York, are putting on the market a new double coil heater. This heater has a riveted steel shell of the same thickness as the Jointless Fire Proof Steel Heaters, and the same heavy, high class parts supplied with these heaters are also made for the riveted. Diameter is smaller than that of the Double Coil Fire Proof Heater, and it will take up less room; heating power is, however, as great.

The firm wishes to impress their customers most strongly that there are several infringements of heaters being sold as theirs, and would advise that orders be sent direct to them.

A week or so ago, with the thermometer gone down away below the zero mark, one of the new 4-6-2 engines on the Boston & Maine hauled a passenger train of nine cars, seven of which were Pullmans, and arrived on time at Worcester, Mass. The work done was not "half bad," as our English friends would say, when it is remembered that there are some very steep grades on that part of the line, and the fireman had not only to "keep her hot" against the atmosphere with cold waves to give away, and had to keep the passengers from becoming "hot" under the collar by keeping the coaches warm.

"SLIGO" IRON

The Standard for Eighty Years

for

DUCTILITY and TOUGHNESS

Staybolts

Unexcelled for Piston Rods

Crank Pins

AND DIFFICULT FORGINGS

SLIGO IRON & STEEL CO.

Successor to Phillips, Nimick & Co.

PITTSBURGH, PA.

Photographs

of Locomotives from railways all over the globe. The Largest collection on earth. Over 10,000 varieties of Locomotives, cars and trains from American, British, French, German, Italian, etc., etc., railways. Samples 6x4 inches, 25 cents; 5x10 inches, 36 cents, postage paid.

ILLUSTRATED PRICE LIST FREE

THE LOCOMOTIVE MAGAZINE

Full of railway pictures and information. 6 cents a copy, postage paid.

SEND DIRECT TO

Locomotive Publishing Co., Ltd.

The World's Railway Photographer
3 Amen Corner, Paternoster Row, London, E. C.
New York Agents, The Derry-Collard Co., 258 B'way
London Agent, Railway and Locomotive Engineering



Moran Flexible Steam-Heating

Connection, All Metal. . .

ESPECIALLY APPLICABLE BETWEEN

ENGINE AND TENDER.

MORAN FLEXIBLE STEAM JOINT CO., Inc.

No. 149 Third Street, Louisville, Ky.

The McCORD BOX

KEEPS OUT THE DUST.



SEE HOW THE LID FITS.

McCord & Company,

CHICAGO

NEW YORK

FOR SALE
FREIGHT, PASSENGER AND LOCCING
LOCOMOTIVES
AND
CARS QUICK DELIVERIES
F. M. HICKS, 315 DEARBORN ST. CHICAGO, ILL.

JUST PUBLISHED
—THE—
LOCOMOTIVE UP TO DATE
The greatest accumulation of new and practical matter ever published treating upon the construction and management of modern locomotives, both
SIMPLE and COMPOUND
By CHAS. McSHANE
Author of "One Thousand Pointers for Machinists and Engineers."
Special Exhaustive Articles were prepared for this new book by the
Baldwin Locomotive Works
Rogers Locomotive Company
Schenectady Locomotive Works
Pittsburg Loco. and Car Works
Brooks Locomotive Works
Dickson Locomotive Works
Cooke Loco. and Machine Co.
Richmond Loco. and Machine Co.
With contributions from more than one hundred prominent railway officials and inventors of special railway appliances.
736 Pages, 6x9 inches 380 Illustrations
An Absolute Authority on All Subjects relating to the Locomotive
Bound in Fine Cloth, \$2.50

ONE THOUSAND POINTERS
—FOR—
MACHINISTS and ENGINEERS
By CHAS. McSHANE
(Practical Machinist)
Assisted by CLINTON B. CONGER, Air Brake Expert; J. P. HINE, Mem. Div. 37, B. of L. E.; J. G. A. MEYER, Mechanical Engineer; W. M. F. GOSS, Mechanical Engineer; JNO. C. WHITE, Indicator Expert. The only complete work on the locomotive combining both theory and practice. 342 pages, 187 illustrations.
BOUND IN FINE CLOTH, \$1.50
The only book ever indorsed by the International Association of Machinists. Agents wanted everywhere; write for terms, commissions and club rates. Will be sent prepaid to any address upon receipt of price.
GRIFFIN & WINTERS, Pub.
171 La Salle St., CHICAGO, ILL., U. S. A.

The Franklin Railway Supply Company is the new name of what was formerly the Coffin-Megeath Supply Company. The fact that this well-known supply company have changed their name will not in any way affect the personnel of the company. No changes in the officials have taken place. Mr. J. S. Coffin is president, Mr. Samuel G. Allen is vice-president, Mr. S. T. Callaway is secretary, Mr. D. D. Mallory is treasurer and Mr. Charles Miller is chairman of the executive board.

The enormous steaming capacity required in boilers on the large ocean steamships can only be attained by means of artificial draft. The fan blower may be found in all these steamships supplying air to the boilers as "forced draft." The International Navigation Co.'s steamship "St. Louis" has eight new Sturtevant fans for this purpose, each one of which is driven by a Sturtevant compound engine.

The last week of the year just past at the Schenectady branch of the American Locomotive works was notable in at least one respect, namely, that of establishing a new record for the output of engines. During those four work days, 13 engines were turned out from the erecting floor, as against a normal output of two per day. The locomotives were a portion of an order of 45 which are being constructed for the Erie road.

Mr. S. R. Calloway, president of the American Locomotive Company, makes the following statement: "We are turning out fifty engines every week, and I do not need to tell you that is a big lot of engines. Our eight plants are working night and day, and we are far behind in our orders. Next year, however, our business will probably drop down to normal—for the first half of the year at least, that is to be expected, as the whole country has been keyed up to the highest pitch in business."

Arrangements are being made by the eastern trunk lines for handling private cars of officials or companies that will displace the practice of moving such cars free in return for reciprocal favors upon a basis of 18 first class tickets for the distance without a stop-over. Switching arrangements limited to the coupling to and removal from trains and yard storage rated according to the present standard after 24 hours, is to be continued for another year.

When a locomotive begins to give annoyance from leaky steam pipe joints in the smoke box, the condition of the cylinder fastenings demands attention. Loose cylinders nearly always cause leaky steam pipe joints.

Besides **ASHTON** LOCOMOTIVE STEAM GAGES
WE MAKE
Duplex Air Gages
Gage Testers
Blow-off Valves
Chime Steam Whistles
Pop Valves
ALL OF A SUPERIOR QUALITY.
Catalogue Lon Application
The Ashton Valve Company, 271 Franklin Street Boston, Mass.



Patents.
GEO. P. WHITTLESEY,
MCGILL BUILDING, WASHINGTON, D. C.
Terms Reasonable. Pamphlet Sent

CONTENTS.

	PAGE.
Air Brake Department.	
*Brake Retardation at Different Periods of the Stop, 88; Brakes, American, in Russia, 87; Cylinder, *Air Pump with Water Jacketed Air, 88; *Pump, Air, With Water Jacketed Air Cylinder, 88; Pumps, *Duplex Air, 90; *Series Arrangement of Air, 87; *Retardation, Brake, at Different Periods of the Stop..	88
Appliances, Patented, Discussed in Railroad Clubs.....	81
Biography of Calvin A. Smith.....	86
Blows and Pounds in Simple Locomotives..	77
Boiler, Superstitious Preventative of, Leak..	56
Book Reviews.....	72
Car, *Vanderbilt Steel Hopper, for Coke 57; *Box, with Steel Underframe.....	79
Cleverness, Inherited.....	56
Cylinder, Lubrication of, and Valve.....	63
Disasters, Railroad, and the Chancetaker...	71
*Drawgear, Continuous, and Rough Handling	56
Engineers, When Reliable, Were Scarce....	55
Flue, Leaky, Hoodoo, 54; *Machine for Expanding and Swaging.....	80
Front Ends, Locomotive.....	79
*Furnace, Metal Melting.....	94
Habit, Power of.....	57
Journal Box, *Handy Jack Block.....	93
Knowledge, Acquiring Useful.....	81
Leak, Preventative of Boiler.....	56
Library, The Value of a.....	53
Lights, Running Past Extinguished Signal. Locomotive, *Seaboard Air Line Ten-Wheel Passenger, 55; *Growth of the, By Angus Sinclair, 59; *4-4-2 Passenger for the Wabash, 73; *Pennsylvania 4-4-2, 77; *Ten-Wheel Passenger, for Atlantic Coast Line	81
Locomotives, Tests of, at Lowell, 63; What Should Be Maximum Economical Load for, 64-65; Old "Franklin," 66; Slipping of, When Shut Off, 67; Blows and Pounds in Simple, 77; Front Ends.....	79
Lubrication, Cylinder & Valve.....	63
*Machine for Expanding and Swaging Flues	80
*Metal Melting Furnace.....	94
*Packing, Self-Adjusting Piston Rod.....	67
Patented Appliances Discussed in Railroad Clubs.....	81
Personals	85
*Piston Rod, Self-Adjusting, Packing.....	67
Portraits, *George S. Griggs.....	61
Pounds, Blows and, in Simple Locomotives, 77; Preventative of Boiler Leak.....	56
Questions Answered.....	72
Railroad Disasters and the Chancetaker, 71; Patented Appliances Discussed in, Clubs, 81; Signal, Running Past Extinguished, Lights, 84; *Signals and Signaling, By Geo. S. Hodgins, 74; Slipping, Locomotives, When Shut Off.....	67
Smith, Biography of Calvin A.....	86
Staybolts, Why, Break.....	58
Telegraphs, Early.....	57
Tests, Locomotive, at Lowell.....	63
Theories, That Do Not Work Out.....	70
Tools, Getting Work out of Machine, 58; Machine, 68; *Unique, holder.....	95
*Trees, Cutting Down Big.....	82
Valve, Lubrication of Cylinder and.....	63
Wheel, Forged Rolled Steel Car.....	83

A (New enlarged edition.)
300 page book on **ELECTRICITY**
by express (prepaid)
Over 100 illustrations
Page 7 x 10 Bound in green buckram

90c.

PRACTICAL LESSONS IN ELECTRICITY

To demonstrate the standard of our instruction, we have bound up four representative text-books in our Electrical Engineering course in a handsome linen cover under the title of
PRACTICAL LESSONS IN ELECTRICITY
and will send one copy for ninety cents (the cost of binding and express charges) to every reader of LOCOMOTIVE ENGINEERING sending us the names of two friends interested in Engineering. Address known to H. E.
The book is easily worth \$3.00. First edition exhausted in two weeks. New edition contains 50 additional pages with numerous cuts, diagrams, etc.
(If not convenient to obtain money order send dollar bill and difference will be returned.)
The subjects embraced are:
STORAGE BATTERIES
By Prof. F. B. Crocker, Columbia University
ELECTRIC WIRING. By H. C. Cushing, Jr., author of "Standard Wiring."
ELECTRIC CURRENT. By L. K. Sager, S. B.
ELEMENTS OF ELECTRICITY. By L. K. Sager, S. B.
Illustrated 200-page quarterly Bulletin, giving full outlines of 60 different courses in Engineering, will be sent free on request.
AMERICAN SCHOOL OF CORRESPONDENCE
AT
Arnour Institute of Technology Chicago, Ill.

Railway and Locomotive Engineering

Copyright by Angus Sinclair Co.—1904

A Practical Journal of Railway Motive Power and Rolling Stock

Vol. XVII.

174 Broadway, New York, March, 1904

No. 3

The Radebaugh Tunnel on the Pennsylvania.

Our frontispiece illustration shows the block signal bridge at the entrance of the Radebaugh tunnel on the Pennsylvania Railroad. This tunnel is situated about thirty odd miles east of Pittsburgh, and is just about wide enough to hold two tracks. As the

tracks become involved or "gauntletted" just before they enter, and all the way through the tunnel; and, though it is impossible for a passenger train to leave the passenger line, there being no switch, yet it would completely obstruct the freight line for the same direction of movement while within the tunnel.

raising the two "homes" to "danger" and the two "distant" to "caution," as it passes under the signal bridge. With these signals in the "stop" position, neither a following passenger, nor a following freight train can advance beyond the bridge. As soon as the passenger train passes under the signal bridge beyond the other end of the tunnel,



RADEBAUGH TUNNEL ON THE PENNSYLVANIA RAILROAD.

Pennsylvania is here a four track road, it is evident that the four lines must narrow down to a little more than the width of two, in order to pass through.

On the right of the picture the two "going" tracks appear. They narrow down near the entrance, and on the left, the two "coming" tracks are seen to diverge from the portal of the tunnel. Following the "going" lines with the eye, it will be apparent that the two

The actual fouling point for the "going" tracks is, of course, just a little way this side of the tunnel entrance, but the signal bridge is by arrangement the track circuits made to act as the fouling point, and the signals on the bridge indicate a clear or a blocked line from that point. A passenger train moving along the "going" track at the extreme right operates the four signals governing the "going" lines—

both the "home" and "distant" signals governing the "going" freight track assume the "all clear" position, and the "home" on the "going" passenger line drops to "all clear" while the "distant" remains at "caution" until the passenger train has entered the block next ahead, as in ordinary signaling practice. A "going" freight train will also operate all four of the "going" signals and "clear" both on the passenger

track and its own "home" when it reaches the similar signal bridge just beyond the tunnel.

Our illustration shows one of the "going" tracks occupied, though the speck of daylight seen in the far portal of the tunnel shows that the train has passed through, but has not yet reached the signal bridge beyond. On the "coming" tracks the signals do not indicate that the tunnel lines are occupied, but that a freight has just passed the spectator, while a passenger train is safely on its own line away behind the spectator and in the block next behind him.

"Last Call for Dinner in the Dining Car."

BY A. O. BROOKSIDE.

"Once upon a time," as the old fairy tales used to begin, there was a railway which used enormous figures on the tenders of their engines, and on one occasion this led to two square meals being quite thrown away, and this is a sober and serious fact, without anything of the fairy tale about it.

Two engines, hauling freight, were started out one exquisitely beautiful summer morning from each terminal of a division of the Quick Thought & Happy Knack Railway, one engine going north and one going south. The engine going north we will call 888, it belonged to station Alpha, which was the headquarters of the division. The other engine, 777, belonged to Omega, and was proceeding south from that point. The crew of each engine lived where their engine belonged.

All went merry until they met about the middle of the division. They met, and no mistake, and it was on a bit of excellently ballasted single track main line without a siding within miles of them. Whether the engineers forgot their orders or whether the dispatcher was of the "bust it" variety, is a matter of little moment now. They got together in good shape, though no one was hurt.

When they all looked over the situation they found it was on this wise: Northbound 888 had her tender badly smashed at the back, and the tank was stabbed through and through so that it would not hold water. In this respect it resembled the explanations of the crews when they subsequently appeared "on the carpet." Engine 777 had her front end badly smashed. The pilot, buffer beam, front foot plate and headlight were completely destroyed and one of her frame fronts was bent, and it was feared that one of her cylinders had been put out of business, but they were, perhaps, looking on the dark side of things just then. Engine 888 had her pilot smashed, of course, but other-

wise she was not damaged to speak of. The breaking up of things in general at the front end of 777 no doubt saved her tender and, luckily, only a wheel or two was off the track.

The locomotive foreman belonging to Omega happened to be traveling home on the northbound freight, and he was a bright young man, and when he surveyed the wreck he at once saw that by a judicious combination one serviceable engine might be made out of two smashed up ones, and he made a suggestion.

Both engineers were too sorry about the wreck to do any kicking, and, besides, they were sensible enough to know a good suggestion when they heard it from a bright young man, and so all hands turned in and by and by they had things fixed up and were ready to ask for orders. They had, on permission from the proper authority, used a freight engine which happened along while they were working. Engine 777 had a good tender and 888 was a good engine—that is, comparatively. As the melancholy meeting had taken place near the center of the division, they had not far to go to find a Y, where, with the help of the freight engine which, as we said, had happened along, they turned the tender of 777 and coupled it up to engine 888. They received order for 888 to go on to Omega with a train which she had been endeavoring to do when collided with. Engine 777 and the wrecked tender of 888 were coupled together, with the shackle bar in the tender tail casting, and they were chained to the end of the south bound freight which had happened along in the nick of time, and they began an ignominious journey toward the back shop at Alpha.

The day wore away and toward evening engine 888, fed with fuel and water from the erstwhile tender of 777, steamed into Omega with the air of a conqueror, dragging the vanquished at his chariot wheel. Now, the wife of the engineer of 777 was looking out of the window at nothing in particular, when she saw what she believed to be 777 passing at no great distance from the house, so she said to nobody in particular, "Well, if that ain't Bill back again. I guess they turned him on the 'Y' at Kappa." Thereupon Mrs. Seven Seventy-seven hastily adjourned to the kitchen and put on a good juicy piece of beefsteak to broil; she got out the frying pan and a bowl of dripping, and cut up some boiled potatoes wherewith to make fried potatoes; she prepared some coffee, the aroma of which would have held an epicure enthralled, and finally spread a snowy tablecloth, and bustled about, as housewives can, to get things ready for "Bill."

While all this was going forward in

the good town of Omega, Mrs. Three Eights, far away in Alpha, was informed by her little girl, who had been gazing at the railroad track from afar, that 888 had come in and as well as she could make out was pushing a train into the long siding. Mrs. Three Eights exclaimed, "Land sakes; who'd a thought it; Jim in again to-night. Good!" This estimable lady at once proceeded to get supper ready, and an At meal it was, too, with heaps of good buttered toast and poached eggs, with a pinch of pepper on the round, white top of each, mind you, and marmalade and, in short, everything which a hungry man with a good railroad appetite ought to enjoy.

It may be here related that the gusto with which each wife prepared for her lord and master was partly due to the surprise element which an unexpected and welcome return is supposed to produce. When Jim and Bill later on heard of what had happened at their respective homes they were awfully sorry about the collision, and were heard to say so in tones of deep sincerity.

As it was, Jim was trying to keep body and soul together on cold victuals out of his once "full dinner pail" in the dreary bunk room at Omega, while Bill was just 130 miles due south of the broiled beeksteak, the fried potatoes, the delicious hot coffee, and the snowy tablecloth, aforesaid. He was in a small hotel in Alpha, too late for the regular meal, doing the best he could on scraps and generally up against it, while hot buttered toast and poached eggs—with just a touch of pepper, thank you—were growing cold, a couple of blocks away, for want of a robust eater.

So it happened on that more than melancholy day, that the bright, young foreman from Omega scored all round, and that evening rejoiced in the bosom of his family and inwardly congratulated himself on having done a good thing for the Q. T. & H. K. Railway, and of how he had promptly let his "old man" know of it by wire. He was complacent and happy, though he had caused the substance of two most worthy men to be, so to speak, wasted on the desert air, and the fatted calf to be killed, as it were, out of season, while the two prodigals were still busy, you might say, with the husks, each in a strange country.

Moral—If you are a bright, young young man things will probably come your way. Never make a triumphal entry into a town with another man's tender; and, remember, that the magnitude of figures on the tank have no relation to the size or to the squareness of the meal you will get on arrival at the terminal station.

Faith That Pumping Water Into a Red Hot Boiler Would Not Cause Explosion.

We do not remember any case where an engineer displayed so much confidence in the faith that was in him as Dr. Coleman Sellers did years ago during tests of boilers. There was a belief not yet dissipated that pumping cold water into a hot boiler was likely to cause an explosion. Dr. Sellers felt assured that no such effect was likely to be produced. He attended a series of tests of boilers made by the United States Government, one of them being to heat the furnace sheets red hot and then pump in cold water. Dr. Sellers stood by the boiler during this test and just as the pump was started held a piece of wood on the side of the boiler to convince himself that the sheets were hot enough to char

The boiler is 62 ins. diameter outside at the smoke box end and is 160 ins. long to front of throat sheet. It is of the wagon top type and the gusset sheet gives an enlargement sufficient to make the third or dome course 70 1/8 ins. in diameter. The crown sheet and the roof sheet are both level, though the back sheet slopes 19 1/8 ins. The staying is

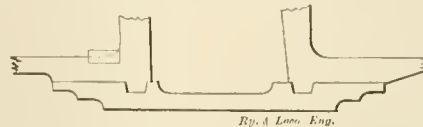

PEDESTAL BINDER—L. & N. RAILROAD

radial, the heating surface is 2,247 sq. ft. in all, of which 2,086 is in the flues. The grate area is 33 1/3 sq. ft. There are 297 tubes in the boiler, each 13 ft. 6 ins. long. The pressure carried is 190 lbs.

Driving Wheels—Diam. of outside, 67 ins.; journals, main, 9x12 1/2 ins.; others, 9x12 1/4 ins.
 Wheel Base—Driving, 13 ft. 3 ins.; total engine, 24 ft 5 ins.; total engine and tender, 51 ft. 4 ins.
 Weight—Total engine, 160,195 lbs.; total engine and tender, about 260,000 lbs.

Philadelphia Car Association Figures.

To those who enjoy statistics the thirtieth annual report of the Philadelphia Car Association will prove interesting. There has not been a better year than 1903 since as far back as 1880. Last year 1,837,605 cars were handled, and this is an increase of more than 13 per cent. over 1902. The average detention, however, has slightly increased. In 1903 the detention was 1.46 days per car, while in 1902 cars were detained 1.43 days per car. The "total refunds" of 1903 are greater than those of 1902 by 22.14 per cent. The lover of statistics can calculate the total refunds for last year,



LOUISVILLE & NASHVILLE TEN WHEEL PASSENGER ENGINE.

the wood. They did that and the effect of pumping in the cold water was that the sheets shrunk so that the boiler leaked all the pressure away.

Baldwin Passenger 4-6-o.

The Louisville & Nashville Railroad, of which Mr. T. H. Curtis is superintendent of machinery, have recently increased their motive power with some examples of very serviceable ten wheel power for passenger work. The engines were built at the Baldwin Locomotive Works, and are simple slide valve engines with cylinders 20 by 26 ins. The driving wheels are 67 ins. in diameter, and the engine truck has 33 in. wheels. All the wheels are flanged and the valve gear is of the indirect motion type, with transmission bar made to pass over and also to bolt under the leading driving axle. The pedestal binders are of the ordinary type with ends which are stepped down, making two reduced thicknesses where bolts pass through.

The weight of the whole machine is about 160,195 lbs., the adhesive weight being about 123,995 lbs., while the engine truck carries nearly 36,200 lbs. Taking the M. E. P. in the cylinders at 85 per cent. of the boiler pressure, the calculated tractive effort of this engine is about 25,000 lbs., and the ratio of tractive power to adhesive weight is as 1 is to 4.95.

The tender is of ordinary form and the tank has a water capacity of 5,000 gallons. Both injectors are on the right side and the tank has a well on that side with plugs in it by which the strainers can be reached without taking down the hose bags. A few of the principal dimensions are as follows:

Boiler—Thickness of sheets, 5/8 and 1 1/8 in.
 Fire Box—Length, 120 1/2 ins.; width, 40 ins.; depth front, 68 1/2 ins.; depth back, 65 1/2 ins.; thickness of sheets, sides, 3/8 in.; thickness of sheets, back, 5/8 in.; thickness of sheets, crown, 1 1/8 in.; thickness of sheets, tube, 3/8 in.
 Water Space—Fut., 4 ins.; sides, 3 1/2 ins.; bk., 3 1/2 ins.

when it is stated that this 22.14 per cent. increase of which we speak amounts to \$2,055.86. This calculation will be found to be much more simple and satisfactory than trying to find the age of Ann.

Tremendous Strain on the Memory.

We have noticed the following in a recent issue of one of our New York daily papers: "Engine drivers working from Crewe to London and back have to notice no fewer than 570 signals." We have seen comments upon the same subject made in other papers, all of which went to show the great strain which was put upon a man running an engine, and the strain was run up and the word "tremendous" was used when it was pointed out that at the same time he had lots of other things to look to and think about.

We do not belittle the good work done by any man running an engine; it re-

quires the use of trained faculties and is the work of brain and hand. The 570 signals which are presented to the gaze of the English engine driver on his run from Crewe up to London and back again, are not presented to him all at once or all together. They are strung out along the line at definite intervals, and as he looks for them there is no enormous strain on his memory. They stand there as a guarantee of good faith by the company, and they give him the right of track when they say, "all clear."

If any newspaper in the country was to print an article on "tremendous strain on the digestion," and then gave in detail the tons of beef, the bushels of potatoes, the pounds weight of turkeys, the number of lobsters à la Newburg, and the gallons of tea and coffee, etc., which the average man consumes in a year, it might well cause him to look upon the amount with fear and trembling if he had to eat all these things at one sitting. He does not, however. They are spread along the road of life at pleasant intervals and are no more

with the back edge of port 5, the valve is beginning to admit steam to the front end of the cylinder, and the valve moves forward until the extreme travel is reached.

With the slide valve the valve is traveling backward while the front port is being opened. Consequently with the internal admission valve the eccentric controlling the valve leads instead of follows the crank pin and is as much more than 90° ahead as it is less than 90° back of the pin when the external admission valve is used, provided both valves have an equal lap and lead.

With the piston valve the marking of the valve stem is more difficult than with the slide valve, because the position of the live steam rings cannot be seen when the valve is in the chamber. The positions of the valve when steam is beginning to be admitted to the cylinder can be found by measurement, by the following method:

Before the valve is put into the chamber, place a straight edge across the front chamber head joint, as at *g*, Fig. 1, being particular to have the straight

have to move 1 inch either way before the steam port commences to open.

After ascertaining the steam lap of the valve, lay the strip on the valve again, with the line *d* in line with the back side of ring 4, then if the line *a* comes back of the front side of ring 1 the valve has exhaust lap and its amount is equal to one-half the distance between the line and front side of ring. But if the line *a* comes ahead of front side of ring 1 the valve has exhaust clearance by half the difference.

The valve shown in Fig. 1 is line and line on the exhaust side, or, in other words, the distance from the back side of ring 4 to front side of ring 1 is the same as the distance between the front edge of port 5 and back edge of port 6, or *a d* Fig. 1 is equal to *a d* Fig. 2.

The lap of the valve has now been found and it can be put in place in its chamber.

Before marking the stem, two gauges should be made for finding the positions of the valve when it is beginning to open the steam ports. Since the valve is line and line on the exhaust side, the distance from *g* to the front side of ring 1, Fig. 1, is the same as *g a*, Fig. 2, and since the valve has 1 in. steam lap, it will move 1 in. either way from its central position before the ports open.

On the strip of iron represented by Fig. 2, and 1 in. (the lap of valve) each way from *a*, draw the lines *m* and *n*.

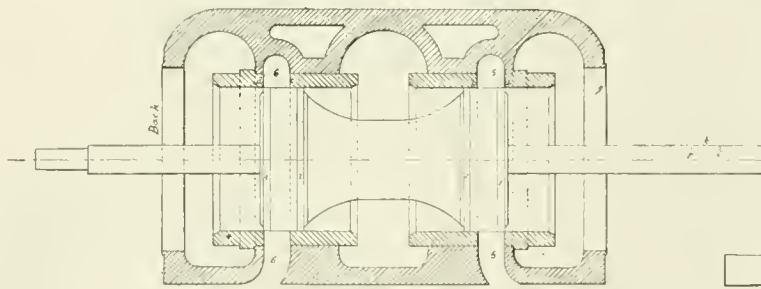

FIG. 1.



FIG. 2.—STRIP OF BAND IRON.

difficult of digestion when taken at the proper time and place than are the recognition and obeying of the 570 separate railway signals on the road between London and Crewe.

Setting Inside Admission Piston Valves.

BY IRA A. MOORE.

I have formerly dealt with setting the common form of slide valve, by which the steam is admitted to the cylinder past the front and back edges of the valve. Many locomotives are now equipped with the piston valve, the greater number of which are internal admission, similar to the one shown in Fig. 1. With this style of valve the steam comes from the boiler through the steam pipes into the cavity *s*, and is admitted to the cylinder past the rings 2 and 3, and through ports 5 and 6. The reader is cautioned to remember, that with an indirect valve motion, the eccentric always follows the crank pin, but the internal admission valve is an exception to the rule, as a study of Fig. 1 will show.

edge in line with the inner surface of the chamber wall. Fig. 2 is a strip of band iron, say $\frac{1}{8} \times 1\frac{1}{2}$ inches, with the end *g* made perfectly square.

On this strip lay off the distance *g a*, equal to *g a*, in Fig. 1. Similarly transfer the distances *g b*, *g c* and *g d* to the strip as shown at *b*, *c* and *d*, Fig. 2.

If this part of the work has been accurately done, the distance between *b a* and *d c* will exactly equal the width of the ports 5 and 6, Fig. 1, and the correctness of the measurements can be proved by setting a pair of callipers to the width of the port and then trying them on the strip of iron.

If the lines on the strip do not correspond to the calipers, the measurements should be taken again, to locate the error. Now lay the strip on its edge on the valve and parallel with the valve, placing the line *c* in line with the front side of the ring 3, Fig. 1, and then measure the distance between the line *b* and the back side of ring 2. This distance will be found, in this case, to be 2 inches, and the lap of the valve is one-half of this, or 1 inch, or, when the valve is in its central position it will

The distance *g m* is the distance the front side of ring 1 will be away from *g*, Fig. 1, when the front port is beginning to open, and the distance *g n* is the distance the front side of ring 1 will be back of *g* when the back port begins to open. Cut a piece of $\frac{1}{4}$ -in. round iron to the length *g m*, Fig. 2, and another piece to the length *g n*.

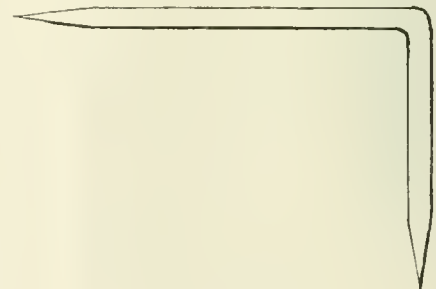

FIG. 3.—TRAM.

Place one end of the shorter gauge against the back edge of straight edge at *g*, Fig. 1, and move the valve until the gauge will just reach between ring 1 and the straight edge.

The valve is now beginning to admit steam to the front end of cylinder and

we will mark the stem in this position by means of a tram similar to Fig. 3.

At any convenient place on the end of the valve chamber make a center punch mark as at *h*, Fig. 1.

With the long leg of the tram at *h* scribe an arc *r* on valve stem.

Move the valve backward until the other gauge will just reach between the straight edge and ring 1, then with the tram scribe the arc *i*, as this indicates the valve's position when the back end of cylinder is beginning to take steam. The valve stem can be marked without the use of the gauges, and some workmen prefer not to use them.

Referring to the valve shown in Fig. 1, it was found to have 1 in. steam lap and to be line and line on the exhaust side; consequently, when the front side of ring 1 is in line with the front edge of port 5 the valve is at half travel, and the back side of ring 2 is 1 in. back of port 5, while the front side of ring 3 is

has exhaust lap, move it backward until the edge of port can just be seen. With the tram make a mark on the valve stem, then move the valve forward the amount of the exhaust lap, when it will be at half travel, and the arc *k* can be drawn and the points *r* and *i* found with dividers as before.

Notice here that when the tram reaches from *h* to *i*, that the back steam port is beginning to open.

If the valve had external admission, or if *e e* were the steam and *s* the exhaust port, then *i* would indicate the valve opening to the front end of cylinder, or, the forward point on valve stem would correspond to front end of cylinder and *vice versa*, the same as when the common slide valve is used. But with the piston valve under consideration, the back point on the stem corresponds to front end and front point to back end of cylinder.

Again, when the valve has lead, the

Freight Power for the Queen & Crescent.

The Rhode Island shops of the American Locomotive Company have recently supplied the Cincinnati, New Orleans & Texas Pacific, of which Mr. J. P. McCuen is superintendent of motive power, with some heavy freight power in the shape of a number of 2-8-0 engines. This system is commonly called the Queen & Crescent Route, in compliment to the two important cities which it reaches. Cincinnati is known as the Queen City and New Orleans as the Crescent City.

The consolidation engines, which we here illustrate, are simple, with 20x24 in. cylinders and 52 in. drivers. The weight on the drivers is 107,350 lbs., while the total weight in working order is about 125,220 lbs. With 180 lbs. working pressure, and on the assumption that the M. E. P. is 85 per cent. of the boiler pressure, the engine can exert



A QUEEN & CRESCENT CONSOLIDATION.

1 in. ahead of port 6. With the valve in this position the tram would reach from *h* to *k*, or midway between *i* and *r*.

Now, with dividers, set to the lap of the valve, or, in this case, 1 in., and with *k* as a center, scribe the arcs *i* and *r*, then, when the valve is moved enough to allow the tram to reach from *h* to *r* or *i*, the valve will be at the point of opening or closing, depending, of course, on the direction of its travel. Suppose the valve to have $\frac{3}{8}$ in. exhaust clearance, instead of being line and line. Then the front side of ring 1 would be that amount back of front edge of port 5 when the valve is central in the chamber, and this position could be determined without the use of the gauges mentioned above, by simply measuring between ring 1 and front edge of port 5.

Suppose again, that the valve has $\frac{3}{8}$ in. exhaust lap. Then the front side of ring 1 is $\frac{3}{8}$ in. ahead of front side of port 5 when the valve is at mid travel, and, of course, the port is out of sight. Hence, to mark the stem when the valve

tram point will come the lead back of *r* and in front of *i* when the crank-pin is on dead center, the same as with the slide valve.

To increase the lead with the slide valve the eccentric is turned toward the crank-pin. When the piston valve is used, the eccentric is moved away from the pin to increase the lead.

The manner of locating the dead centers, "squaring" the engine, and getting the engine to cut off the same in each cylinder is the same as with the slide valve. To equalize the cut off in each end of the cylinder the length of the blades must be changed opposite to the change when setting a slide valve, or, to make the cut off take place earlier in the front end and later in the back end of cylinder with the slide valve, the blade would have to be shortened; with the piston valve the blade must be lengthened to produce this result.

A careful study of Fig. 1 will be helpful in getting these things fixed in the mind. Cedar Rapids, Ia.

a tractive effort of about 28,250 lbs., when moving at a slow speed on the level, without sand. The ratio of tractive effort to adhesive weight is as 1 is to 3.8.

The wheels are all flanged. The pistons drive on the third pair. The valve motion is indirect gear with a balanced D slide valve. The pony truck wheels are equalized with the leading drivers in the usual way, and the main driver and the two trailers are equalized together. The main rod is of I section, and the side rods are rectangular in section with solid ends.

The boiler is of the straight top kind with wide fire box and the outside diameter of the first ring is 60 ins. The barrel, fire box and fire-box casing are made of carbon acid steel, $\frac{1}{8}$ ins. thick. The heating surface is 1,812.1 sq. ft. in all, distributed so as to have 1,685.9 sq. ft. in the tubes, which are 240 in number and 13 ft. 5 ins. long. The fire box heating surface is 109.4 sq. ft., and the heating surface in the water tubes sup-

porting the brick arch, amount to 16.8 sq. ft. The grate area is 39.3 ft.

The tender frame is made of 10 in. steel channels, and the tank has a water capacity of 4,000 gallons and the coal carried is 8 tons. The weight of engine and tender in working order is about 213,050 lbs. A few of the general dimensions are appended for reference, as follows:

General Dimensions—Wheel base, driving, 14 ft. 10 ins.; total, 22 ft. 8 ins.; total engine and tender, about 49 ft. 3½ ins.

Cylinders—Size of steam ports, 18x1½ ins.; exhaust ports, 18x3 ins.; bridges, 2x1 ins.

Valves—Greatest travel of slide valves, 5 ins.; outside lap, ¾ in.; inside, line in line; lead in full gear, ¼ in. forward; ¼ in. lap backing.

Boiler—Style, wide fire box straight top; outside diam. of first ring, 60 ins.; working pressure, 180 lbs.; mat'l of barrel and outside of fire box, carbon acid steel; thickness of plates in barrel and outside of fire box, ⅝, ⅝; ½ in.; horizontal seams, quadruple riveted, circumferential seams, double riveted; fire box, length, 83½ ins.; fire box, width, 65 ins.; depth, front, 60 ins.; back, 47¾ ins.; material, carbon acid steel; fire box plates, thickness, sides, ⅝ in.; back, ⅝ in.; crown, ⅝ in.; tube sheet, ½ in.; water space, front, 4 ins.; sides, 3 ins.; back, 3 ins.; crown staying, 1½ radial stays; stay bolts, 1 in.; tubes, material and gauge, charcoal iron, No. 12 B. W. G.; number, 240; diam., 2 ins.; length over the tube sheets, 13 ft. 5 ins.; fire brick, supported on water tubes; heating surface, tubes, 1,685.9 sq. ft.; water tubes, 16.8 sq. ft.; face, fire box, 109.4 sq. ft.; total, 1,812.1 sq. ft.; smoke stack, inside diam., 16 ins.; smoke stack, top above rail, 14 ft. 3⅞ in.

Tender—Weight, empty, 38,500 lbs.

Ingenious Tube Expansion Machine.

At the Port Richmond (Philadelphia) shops of the Philadelphia & Reading Railway there is a very ingenious air operated machine for making the ends of locomotive boiler flues exactly fit the tube holes in the front tube sheet. It is a home made machine, put together out of what the master mechanic, who got it up, calls scrap material.

It consists of what you may call a table, made of a piece of channel iron mounted on legs. Bolted to a pair of hangers below the channel is a vertical air cylinder which gives an up and down motion to a hook shaped clamp, operated by valve No. 1, the clamp in descending holds a boiler tube tightly down against two V-shaped grooves in a pair of stationary castings, as may be seen in the illustration. When the tube is clamped in position it is, by that operation, centered in line with the axis of the horizontal air cylinder at the end of the machine.

The horizontal air cylinder has screwed on the end of its piston rod a forging very much like a turn buckle, but with this difference: whereas a turn buckle has threads at both ends this "former" has a thread only at one end, and that is the end where it screws on to piston rod. The other end is made a trifle smaller than the exact size, so that when heated by contact with the hot flue end it comes very near to

the correct size of the flue hole in the front tube sheet. When the flue has had its end heated and has been clamped in position, moving the handle of valve No. 2 admits air to the horizontal cylinder and the turn buckle head is forced over the outside of the tube. Just inside the flue opening in this turn buckle head, if we may be allowed to so name it, is a cone shaped expander, which enters the mouth of the tube and expands it slightly more than is required. The return stroke of the horizontal cylinder, controlled by valve No. 2, draws the turn buckle head off, over the tube, and the tube is brought to the exact size of the opening in the turn buckle head. The slight variations in the size of tubes is thus taken care of, and every tube leaves the machine an exact fit for the tube sheet. The time occupied in expanding tubes when in the boiler is consequently reduced by reason of the closeness of the fit produced in this machine.

There are different sized turn buckle heads suitable for different sized flue sheet holes, but the operation is the

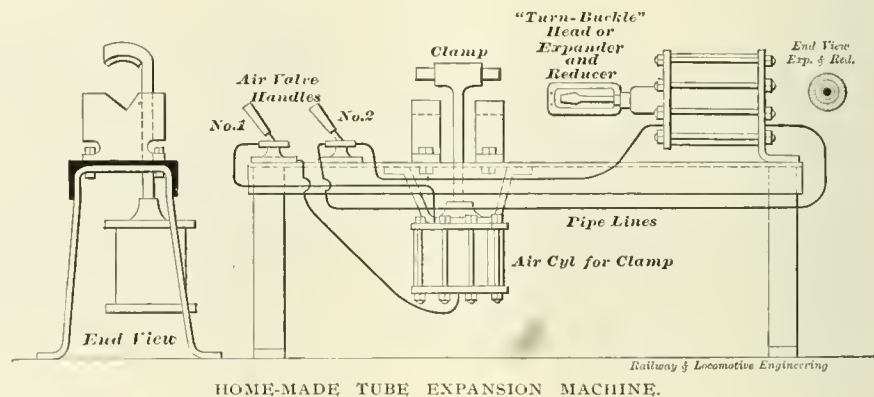

same for all. The tubes handled by this machine only cost about 40 cents per 100 to set.

As will be seen from the illustration the two valve handles stand at an angle of about 45°, leaning toward the left. The operator moves the handle of valve No. 1 to the right, through a quarter turn, and the tube is clamped. He continues the sweep of his hand to the right and moves the handle of valve No. 2 to the right also, and the turn buckle head runs over and into the tube, so to speak. The operator then puts, first the handle of valve No. 2 back to where it was and the turn buckle head draws off and leaves the tube end "finished." Handle No. 1, when put back to where it was, releases the clamp and the tube can be taken out of the machine. A minimum of motion on the part of the operator is thus secured with corresponding reduction of time in doing the work. The helper places and removes the tube as rapidly as he can handle them, and the work goes merrily forward.

The Work of Ross Winans.

BY C. H. CARUTHERS.

One crossing from New York to Liverpool is impressed by the Fastnet Rock standing far out from the mainland of the Irish coast; its precipitous cliffs, resplendent in metallic coloring, towering above the restless Atlantic and crowned by a lofty lighthouse whose belted form by day and intermittent light by night not only marks the beginning or the ending of the ocean voyage, but warns the mariner of the dangers of that iron-bound coast and indicates safe channels for his farther sailing.

So amid the reefs and quicksands which dot that tumultuous ocean of experience over which railway men have directed their courses in days gone by, the figure of Ross Winans shines out in unfading brilliancy; and although in the long ago many refused to follow the ways he indicated, and sailed away into fogs and darkness which often brought dire disaster, yet the winds of experience, sweeping fiercely down the passing years, cleared the air and revealed the light he

shed, glowing more brilliantly than ever, and many then turned into courses he so steadily indicated; proving unquestionably that he was a man greatly in advance of his times.

Gliding far back into the last century until we arrive at the year 1831, we will find Mr. Winans filling the position of Assistant Engineer of Machinery of the Baltimore & Ohio Railroad, his chief being Mr. George Gillingham.

Although the company owned but three or four locomotives, the duties of these men were by no means light.

The locomotive was as yet in its experimental stage and required close attention and care as the service developed new ailments and possibilities, and designing engines of improved types gave ample employment for all unoccupied moments.

About this time Phineas Davis brought out the "York" which, after an early rebuilding, became the first of the famous "Grasshopper" locomotives.

Along with many others, the writer was heretofore of the impression that Mr.

Winans was not identified with the development of this type of engine; but careful investigation of articles from the pens of Messrs. Latrobe and Forney, both of whom were intimately associated with Mr. Winans in his work at that period, shows that he not only assisted Mr. Davis in remodeling the York, but also in designing and building the next two of the type—the Atlantic and the "Indian Chief," the latter afterward renamed "Traveler." This work was done in Mr. Davis' shops at York, Pa., as the company owned no shops at that time; but in 1833 they erected shops in Baltimore and Mr. Davis built his later engines at that place; unquestionably under a close supervision of Mr. Winans.

Soon after the sad death of Mr. Davis in 1835, Messrs. Gillingham and Winans resigned their positions with the railway company and formed a partnership to build locomotives, and arranging with the railway company to use its shops in Baltimore for that purpose. How long this arrangement continued does not appear, but in later years the firm of Gillingham & Winans erected shops of their own on a piece of ground bounded by Poppleton, McHenry and Pratt streets, and the Baltimore & Ohio Railroad, and adjoining the Mount Clare shops of that company.

Mr. Winans built, between 1831 and 1834, the first passenger cars carried on two four-wheeled vibrating trucks. The first of these cars was named Columbus, and its wheels were so arranged that each could revolve independently of its mate on the same axle—perhaps the precursor of the Miltimore arrangement used on cars of the narrow gauge railway in the grounds of the Centennial Exposition at Philadelphia in 1876.

The latest was named Dromedary. It, and most probably the others, had the very simple form of truck used later under the tenders of the Camel engines. This truck consisted of two large half-elliptic springs, one on each side with the convex edge upward and the ends secured to the semi-circular journal boxes by U-shaped strap bolts, and the buckles of these two springs were attached to the ends of a transverse bolster which carried the center plate on its top.

These cars were followed by the building of a "wood-car" on similar lines; and this by a passenger car named Comet, which had the body hung much lower than its predecessors, and was fitted with reversible seats arranged on both sides of a central aisle. The seating capacity of the Comet was 42.

Cars on two trucks of four wheels each had been used as early as 1813 near Merthyr-Tydvil, in Wales, and Mr. Winans does not appear to have claimed to be the originator of the practice.

Mr. Winans' constant efforts were directed to increasing the size, power and

efficiency of locomotives; and in 1836 he brought out his first engine of the Crab type, the Mazeppa. This type differed from the Grasshoppers in having the boiler hung one foot lower, and in using horizontal cylinders by which the more intricate arrangement of rods, etc., which gave the name of Grasshopper to the other engines, was dispensed with, and in increasing the weight two tons.

The blowing fan and cog-gearing of the Grasshopper were retained. Although considered a superior engine, the Crabs do not seem to have been retained in service quite as long as the Grasshoppers.

In 1842 Mr. Winans built two large engines of this type, carried upon four pairs of driving wheels all connected by parallel rods, placed two pairs in front of the boiler and two pairs behind it. These engines were built for, and ran upon, the Western Railway of Massachusetts.

In 1844 he built for the Baltimore & Ohio R. R. an engine named Buffalo, later numbered 35, and always nick-named "Mud Digger" because its great weight sent the mud flying from under the rather loosely-set ties, across the neighboring landscape.

Briefly, it was the preceding type of engine improved by the use of a horizontal boiler and drivers set closely together, and the cylinders at what we now consider the proper end.

The cab shown in pictures of this engine was doubtless an addition of later years.

The year 1846 found Mr. Winans turning out his first direct connected locomotives. They were four in number, were placed in service on the Philadelphia & Reading R. R., and were named by Mr. Winans, Chesapeake, Baltimore, Maryland and Ohio. As the company already had an engine, built by Norris, in service, named Chesapeake, they changed the name of the Winans engine to Delaware.

The boilers of these four engines were of the same type as were afterward used on the first, or short-furnace camels, except that the large hay-stack dome was directly over the higher portion of the fire box.

A metallic jacket covered the upper half of the boiler barrels. The smokestacks had inner and outer sections—the inner straight, and the outer trumpet-shaped.

The enginemen stood upon foot plates, level with the top of the projecting ends of the fire boxes, and these foot plates were surrounded by iron railings but were without roofs.

The frames were double slabs about 8 in. in height, and the cast iron pedestals were placed between them. Although carried to the rear of the fire boxes, these frames were not united at that point by cross framing; and the provision for coupling the tender was substantially the same as followed in the camels.

The eight drivers were set close together between the fire boxes and cylinders, and the latter were set horizontally, line-and-line with the drivers.

The pumps also were placed and operated as in the camels, but the parallel rods were fitted with straps held in place by keys and gibbs.

The valve gear was of the same type as was afterward used on the camels, viz.: drop hooks of D pattern, raised or lowered by half-moon cams on a shaft operated through a spur wheel at its center moved by a sliding bar of cogs moving horizontally in guides and united at one end to the reversing lever. The heart-shaped cams for cut-off, used on the camels, were not on these engines.

The tenders had firing-pits similar to those used on the camels of short fire box type.

The springs were also placed above the frames in the same position as were those upon the camels of the Baltimore & Ohio after their partial remodeling by that company. These were followed in 1848 by the crowning work of Mr. Winans' life, in the placing during that year upon the Baltimore & Ohio R. R. of an engine named Camel, and afterward numbered 55; his first camel engine. It was, of course, of the short-furnace type and was soon followed by those of long furnaces.

These engines have been so often and so accurately described during the past seven or eight years that it will suffice here to mention that from the appearance of the first camel in 1848 to that of the last one in 1860, there were built, 119 for the Baltimore & Ohio R. R., 11 for the Pennsylvania R. R., 1 for the Pittsburg & Connellsville R. R., 21 for the Northern Central R. R., 42 for the Philadelphia & Reading R. R., 6 for the Delaware, Lackawanna & Western R. R., and a few for other roads, the names of which cannot be ascertained, making a total of about 200.

Two of those on the Northern Central came on that road in 1867, 7 years after Mr. Winans closed his shops, and must have been bought by the N. C. R. from some other company.

Referring to the frequent mention of explosions resulting from weakness of construction in the boilers of these engines, the writer can say that the only explosion of any one of the 11 on the Pennsylvania, was that of the Logan, 91, which occurred in 1876, 9 years after Mr. Laird had furnished it with an entirely new flush-topped boiler—except that the original large dome was retained, but placed near the rear of the boiler, and this explosion was principally an internal collapse of the fire box built in the Altoona shops.

The others ran successfully for ten years, and one, the Seneca, retained the original barrel of boiler with large dome on front sheet, until worn out in 1871.

These 11 were bought between January, 1853, and May, 1856, and the only changes made during their first ten years' service were closing the open furnace ends of, and removing the chutes from, the first four received.

Looking backward upon these camels, we are not now surprised that Mr. Winans clung to this type of construction with a pertinacity bordering almost upon monomania.

Boilers set high and provided with long fire boxes, driving wheels eight in number placed close together between fire box and smoke-arch; cylinders of large diameter and set line-and-line with all the centers of driving axles; parallel rods with brass bushed solid ends; all these features enter into the construction of the consolidation engines of to-day, and most of the features into the construction of other types.

His long-furnace camel boiler is closely copied on the "Altoona" boiler of 1875, still used on a large number of the company's consolidation and shifting engines.

His position of cab on the camels is closely followed on all engines built with "Wooten" boilers; but the construction of this boiler in preventing engine-men and firemen being in sight of each other, nullifies many of the benefits of this location of cab on the camels.

This matter of position of engineman appears to have entered largely into Mr. Winans' ideas of construction. He evidently laid stress upon the importance of placing him as close to the front as possible, and this led to his building at different periods, two engines not previously alluded to in this article because they do not exactly form progressive links in the chain of Mr. Winans' work, but are like split-links—merely attached to afford a place on which to hang later developments. Both of these two engines had the engineman's position at the extreme front—on the bumper.

The first was built in 1843, named Carroll of Carrollton, and was operated on the Boston & Worcester R. R.

Its cylinders had a stroke of 48 in.; the drivers were 84 in. diameter, placed under the center of the boiler, and in later years an arrangement of cylinders with pistons bearing upon the tops of the driving boxes was placed above each driver and increased adhesion gained by steam pressure from the boiler. Two four-wheel trucks were used, one under the smoke-arch and the other under the fire box; both of type already described as used by Mr. Winans under cars and tenders.

The other engine was built in 1851, named Celeste, and placed on Philadelphia & Reading R. R. It resembled the Carroll of Carrollton in some respects but used two pairs of drivers.

Indications rather incline one to believe the Celeste to have been more of an off-

spring of Mr. Thomas Winans, but of this I cannot obtain positive data. In many published articles it has unfortunately been confounded with the Carroll of Carrollton.

One other engine of Mr. Winans must be mentioned, the "Centipede," built in 1852, with 8 driving wheels of 43 in. diameter, all connected, and four-wheel truck; to all intents the prototype of the modern Mastodon. Cylinders, 22 in. x 22 in; weight, 45 tons; crosshead and piston forged together. The cab is stated to have been at the front end, but positive data seems wanting as to whether this means on the front bumper or merely in same position as on the camels.

Mr. Gillingham seems to have disappeared from the partnership at an early date and the last camel was built in 1860, and the shops closed in 1861, although reopened and operated for a time by Hayward Bartlett and Co., on other types of engines, but finally closed and torn down during the sixties.

Besides building locomotives, Mr. Winans did some literary work, and a book from his pen entitled, "One Religion and Many Creeds," is said to be well worth reading and to clearly set forth his views.

He has long passed into Eternity and his last camel was retired from service in 1898, but the memory of the remarkable man and of his remarkable productions will remain a permanent heritage of the history of the locomotive.

Railroad Expansion.

In one year alone—in 1897—upward of 13,000 miles of railway were built in this country; in the five years from 1896 to 1900 more than 38,000 miles of new railway were built—an increase of about 30 per cent. in the mileage, although the gain in the number of tons carried per mile of road in this period was hardly 12 per cent. The increase in the capital stock outstanding was about \$640,000,000, or about 16 per cent., and in outstanding funded debt about \$1,319,000,000, or very nearly 30 per cent. Between 1897 and 1902 the outstanding funded capital stock has increased by about \$470,000,000, or about 8 per cent., and outstanding funded debt by about \$904,000,000, or 16 per cent., while the increase in freight movement had been 60 per cent. and in the passenger movement about 66 per cent.—*Review of Reviews*.

What Is Color?

The question of color is one of great complexity, for it involves the profound problems of solar light composed of constituents, refrangible in different degrees, of atoms and molecules of bodies having the power of sifting solar light in

various ways, and thus producing the various colors observed in nature and art. And yet, strange as it may seem, color has no absolute material existence in nature outside of consciousness. It does not exist as an entity in the gorgeous hues of the rainbow, nor in the petals of the rose; these have molecular structures which reflect and refract the light back to the eye of the observer, an impression is produced on the retina of the eye and conducted thence to the sense centers of the brain, where it is transformed into a conscious sensation of color, and we speak of it as a property of things in nature, though in reality it is energy transformed in the brain of organized life forms. Here the mystery is indeed profound, for it is correlated with life and defies analysis or interpretation.

Rise of Paterson.

In 1791, through the exertions of Alexander Hamilton, an association was formed in New York for establishing and promoting useful manufactures. About 5,000 people agreed to subscribe \$100 each. A thorough search was made for a suitable location. As water power for driving machinery was regarded of the first importance, the promoters of the scheme selected a piece of land under the Falls of the Passaic, six miles square, which they called Paterson, in honor of Judge William Paterson, then governor of the State of New Jersey. The great falls are 104 feet high, and were considered capable of driving 247 undershot water wheels. Textile industries flourished in the new town. After the Rogers Locomotive Works were started an impetus was given to that industry and other works of the same character were started and Paterson was for years recognized as one of the foremost locomotive building towns in the country.

Satisfactory Test.

An Irishman was employed on one of our large railroads in some capacity which left the general manager pretty free from any serious Hibernian competition. This son of Erin was greatly impressed on hearing that railway material which gives the best results when tested to destruction, usually does well in service. Not long ago he drew from his pocket a box of matches which the railway company had intended for use in the smoking compartment of a sleeper, and turning his pipe bowl down proceeded to business. He struck several matches, but none would light. At last, after a vicious stroke, one match blazed up encouragingly. "Be gorra!" said Pat, "that's a good match I know—I'll keep that one."

General Correspondence.

Old Locomotive Philadelphia.

The accompanying illustration which is reproduced from an old lithograph issued by the builders, shows an engine of the type with which the P., W. & B. R. R. was almost exclusively equipped up to 1856, when the "Daniel Webster," built by the Taunton Manufacturing Co., with Dimpfel boiler, was placed on the road. The New Castle engines were all similar to that shown in the illustration, except that the truck boxes were outside and were connected by springs, which themselves constituted the side frames, as in the old Winans tenders. As is obvious from the restricted dimensions of the fire box, these engines all burned wood, and in their day they were very serviceable machines. If I remember correctly, their frames were of wood

ton. He went to sleep on the road with the injector stopped and the crown sheet wilted. Here was the report he sent in from a way station:

"Owing to a temporary deficiency of dampness on the roof of the furnace of engine 29, the active combustion of carbon produced caloric intensity sufficient to permanently derange the contour of the sheet, suspend active participation of this locomotive in the transportation department, and require the employment of skilled artisans and mechanical appliances, unattainable at the time and place of such unsolicited and unexpected derangement of crown sheet and schedule, caused by procrastination in the application of appliances for the introduction of water to the interior of the boiler."

do not the railroads transplant trees along their roadbeds, and interest themselves in forestry? Every now and then, as one journeys along the railroad track, he will see where some enterprising individual has planted his little patch of potatoes beside the rails, the authorities of the road giving tacit consent if nothing more. Why can not the great corporations make idle lands pay them thus as well as the individual can? Enormous quantities of timber could be supplied them from this source, for bridge building, and ties, and repairing, and of just the variety which they desired, or found most serviceable. Why are these long stretches of available timber land allowed to lie waste, year after year, with nothing done to make them of value?

Railroad men often complain of the open and exposed places along their lines, where the wind sweeps across with unbridled fury and piles the snow high

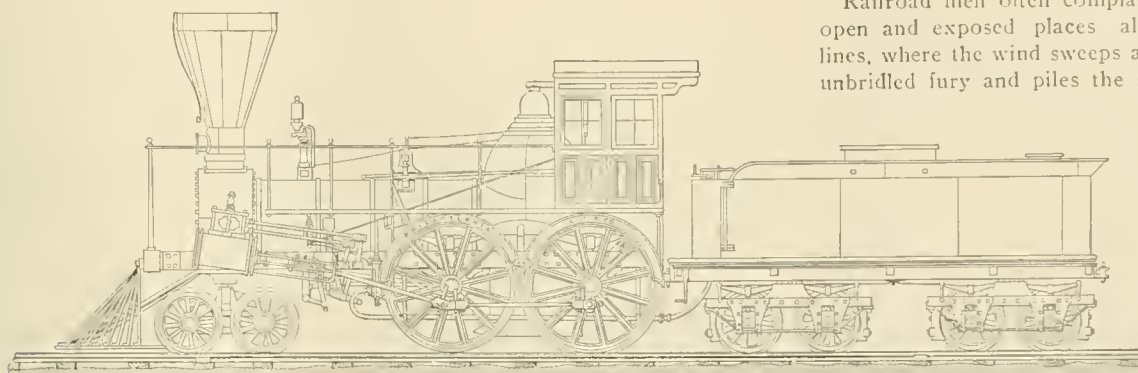

Railway & Locomotive Engineering

PHILADELPHIA, WILMINGTON & BALTIMORE ENGINE, BUILT IN 1852 BY NEWCASTLE MANUFACTURING COMPANY. MADE FROM LITHOGRAPH LENT BY J. SNOWDEN BELL, PITTSBURGH, PA.

with pedestals bolted on as shown, but I am not sure as to this, as they may have been two light plates with wood filler. Among the features which have disappeared from present practice, will be noted the Bury hemi-spherical dome and the independent cut-off valves. The "Philadelphia" weighed 39,250 pounds, and had 13x20 inch cylinders and 5½ feet driving wheels. Most of the other engines were heavier and had larger cylinders, some having 14, 15 and 17 inch. None of these engines were built after 1856, when engines of the ordinary American or 4-4-0 type became the standard of the road.

J. SNOWDEN BELL.

Pittsburgh, Pa.

Two Kinds of Messages.

You had an article some time ago about a certain railway man using big words in his reports. We had an engineer from Boston on the Atlantic & Pacific once who was always called Bos-

The master mechanic wasted no words. He wired, "John Boston, you are fired."

DYCE CONVETH.

Railroads Ought to Cultivate Timber Growing.

BY R. B. BUCKHAM.

To one who has been long in the woods making of lumbering and forestry a life study, there are certain questions in regard to railroading which recur again and again, and he wonders that they are not given wider and more serious consideration. As suggestions come to many which are of service to the railroad expert, through the channels of their daily occupation, so the woodsmen too has his, which he ponders often in the silence of the woods.

First among these is the matter of timber cultivation. Where is the future lumber supply of the country to come from? This is going to become a serious question before long, and one that must be answered in one way or another. Why

on the rails, causing the men a great deal of annoyance and expense to keep the way clear. Temporary shields of boards are frequently constructed at such sections to overcome the difficulty, whereas if evergreens should be planted here instead, they would not only end the trouble once for all, but also prove a valuable crop, increasing in price from year to year, and so serve a double purpose.

Where the railroad penetrates timber belts, and it lies about it on every hand, it treats it with the same utter indifference which it maintains toward it in the manner first mentioned. Timber is a crop of as sure and stable a value as any, yet in the ruthless destruction of it which the railroad causes by fire, it would almost seem to account it of no value whatever.

Every railroad line running through extended woodlands should have its fire avenues on either hand, some six or eight feet in width at least, cleared of all

brush and inflammable matter. These would stop at once the flames caused by an occasional spark in dry weather from spreading away into the woods, and so prevent the extended conflagrations which now, every year, terrorize and endanger whole communities. The railroads are as prodigal of timber where it abounds, as of available space for its cultivation where it is lacking. Surely this is burning the candle at both ends!

But perhaps what has impressed the writer as much as anything, in riding through the woods on the railroad, is the utter lack of attention displayed in the care of the timber along the track. In very many places, the trees stand shoulder to shoulder, for miles, right up to the very track itself, their branches overhanging it above, till the road seems to run through a lofty archway formed by the woods.

And every now and then an old monarch of the woods will be seen long since dead and gone to decay, and ready to drop to earth at the slightest provocation. Countless hosts of these arboreal barons have been destroyed by the railroads, like the Indians, in days gone by, but one of these old patriarchs along the track might reap sweet revenge, if in its final fall it should stretch its gaunt trunk across the track. More than one serious accident has been the result of a much less formidable obstruction than a fallen tree trunk.

Altogether, the suggestion of a woodsman is, that the railway authorities should interest themselves in the subject of forestry, more than they do; encourage the growing of trees upon their lands, take radical measures to prevent forest fires, and devote constant care to the pruning and thinning of such timber as stands immediately along the railway itself.

Fictitious High Speeds.

I note what you say in your last issue about high speeds with steam locomotives. You say that 120 miles an hour is often reported but seldom accomplished. I believe myself that these speeds are often thought to be more than they really are, from the fact that the time between stations or points is usually taken by the clocks or watches in the telegraph office. By this method it is possible to make a quarter or a half minute's difference which would result in giving the wrong time required to run the distance, but if some more accurate means were used to record the speed it would be found that the speed was much lower than was thought.

Even taking the time with a split-second stop watch at mile posts will give or take five or seven miles per hour. It is usually the case to figure the speed too high, for if a train is making a fast run, those men on the train

or in the telegraph office want it to develop into a very fast run. They will unconsciously favor the train and give it the benefit of all doubts.

The operator may take the time just as the train has passed, and take five or six seconds. The next operator may take the time just as the engine comes to the platform, thus favoring the train five or six seconds more.

The men on the train, in their anxiety may snap their watches and unconsciously favor the train. But the majority of impossible fast runs are not errors of timing by either the operator or man or the train. They are assumptions and assertions on the same order as the boy's ghost story, and the newspaper reporter puts on the finishing touches.

AMOS JUDD.

Boston, Mass.

Locating Defects in Schenectady Cross Compound Engines.

Referring to the above heading, the data is rather limited especially regarding the effects of blows in the compound feature, as well as proper way for an engineer to test for locating, so as to report intelligently where trouble is. Then, in case of breakdowns, to get engine out of the way or in running order again in the shortest possible time.

If either main valve or piston packing blows, it can be tested for and located as in a simple engine with separate exhaust valve open; if not found, then take out, and examine over pass valves; they are easy to get at, and are frequently the cause of a blow. If separate exhaust valve leaks it will cause a blow at stack between the exhausts when engine is working compound. If rings on reducing valve leak it will cause a constant leak at drip pipe in rear of intercepting valve. If rings on middle part of intercepting valves leak, it will not make a noticeable blow, but will increase the power in low pressure cylinder when engine is working compound. To locate this defect cover ports on high pressure side (so no steam can enter receiver), block intercepting valve in compound position by slipping a piece of gas pipe over stem of intercepting valve and secure with a nut; move reverse lever so as to open one steam port on low pressure side. Block engine so it cannot move with cylinder cocks and throttle open. Any steam leaking by these rings will blow into low pressure steam chest and out of cylinder cocks on that side. When separate exhaust valve leaks it reduces the power on low pressure side when engine is working compound, and at the same time engine will burn an excessive amount of coal.

Steam leaking by rings on reducing valve will cause it to remain open when engine is working simple (if drip pipe

is stopped up), thereby giving full boiler pressure in low pressure cylinder. Instances have occurred where the intercepting valve has been forced in, upside down; in this case engine will work all right when in compound, but with valve in simple position there will be no escape for exhaust from high pressure side, so engine will make a few exhausts and stop. If separate exhaust valve is opened there would be a terrific blow at stack, as live steam on low pressure side will pass out through separate exhaust valve to the stack. Engines have been run in this condition when, if a better understanding had existed, the trouble could have been located at once.

If main valve or cylinder packing leak on high pressure side the steam is not lost if engine is working compound, as it will pass through receiver and increase the power on low pressure side. If main valve or cylinder packing leak on low pressure side it will be lost, and decrease the power on that side in either compound or simple. If steam issues from both cylinder cocks at the same time on high pressure side when working compound, there is nothing wrong, for there will be boiler pressure on one side of piston and receiver pressure on the other.

If engine does not change to simple when operating valve in cab is opened, it indicates loose filling rings on separate exhaust valve piston; to get engine to change to simple, ease off on throttle, which will reduce receiver pressure on face of separate exhaust valve, and engine should go into simple. If not, drive in on stem of intercepting valve.

To test for poor fitting rings on separate exhaust valve piston, when operated by air pressure, tap the brake valve, and when pump stops open the operating valve and if pump goes to work, the amount of air compressed will be a measure for what is leaking past the rings. If engine does not change to compound when operating valve is closed, it would indicate that the separate exhaust valve had not closed. If rings on reducing valve leak faster than drip pipe can relieve it engine will not stay in compound. The separate exhaust valve should receive the most attention and should be examined and cleaned at least once a month.

If any part of the running gear breaks on either side, disconnect the same as with simple engine and run engine with separate exhaust valve open. With main valve on either side broken, remove the broken valve, plug up stuffing box hole (use valve stem for this, if possible) block intercepting valve in compound position by slipping piece of gas pipe over stem of intercepting valve

and fasten with a nut; leave separate exhaust valve shut. If the valve on high pressure side is broken steam will pass to high pressure cylinder then through the receiver to low pressure side. As the pressure relief valves on low pressure cylinder will only allow about 45 per cent. boiler pressure to stay in cylinder, regulate opening of throttle accordingly. If valve on low pressure side is broken, steam will exhaust through the receiver to low pres-

sure. Conditions often force the promotion of men, whose knowledge is very superficial. That man is thrown on his own resources, and the company increases the loss side of the ledger. Who is at fault? Does it all lie with the man?

The necessity of guidance was recognized, and recommended, in the advice, "Train up a child in the way he should go, and when he is old, he will not depart from it."

out to learn, there was placed in his hand a pamphlet, comprehensively written, comprising the duties of a fireman and a few questions and answers regarding coal, steam pressure, temperature and the boiler, and given to understand his position depended on his answer, not only would the road foreman gain an idea of the new man's mentality, but also start him in the right direction. When he is placed on the roll of eligibles, again give him a book of general questions concerning the locomotive.

How many young men, bright, intelligent and apt, have been spoiled by simply being sent out to learn firing and placed on an engine with a man who could not instruct?

The young fireman has, during his probationary years, seen men advanced who are sadly deficient. He has seen men take chances both on passenger and on freight, and knows it is not always the man who tries to follow rules and exercise judgment that is patted on the back and called good runner and good fellow.

He has fired engines, turned out on road in all conditions of the "good enough for this trip" plan, and if the engine survived the ordeal, returned. He has seen the closest kind of economy practiced in the machinery department; oil, material, supplies, cut to reduce expenses, and when a lull in business came, the shop force reduced, while in the other department, not a

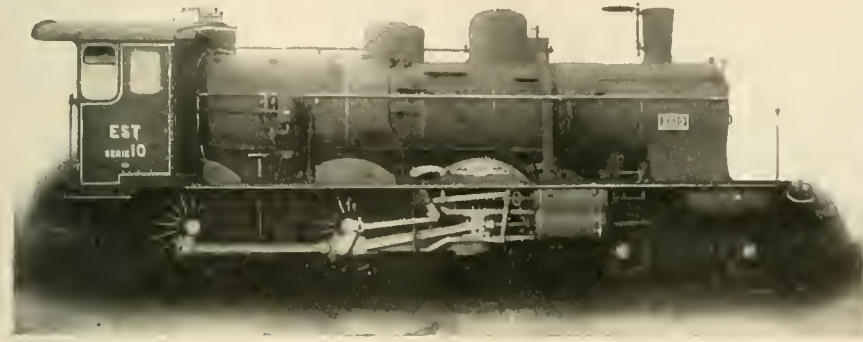

GERMAN BUILT ENGINE FOR EASTERN OF FRANCE.

sure cylinder and out exhaust to stack; in these cases there will be live steam on both sides of the piston on disabled side, but I would not take main rod down in either case, as that is quite a job, and, besides, I would try to get out of the way in as short a time as possible. If rod is taken down, block cross head securely as boiler pressure will be in cylinder.

Allowing for the differences existing between the motive power department of a railroad and other callings, still, the argument of commencing at the beginning of a young man's career, holds good. The fact of a man firing a number of years, and having access to shops, round houses and road service, and at the expiration of several years still unable to pass a creditable examination,

With nothing apparently broken, but engine refuses to move, see if high pressure side is on the center; if so, examine stem of intercepting valve, and if found extending back about 7 inches, drive it in to simple position; if only out about 3 inches the intercepting valve is in proper position, but reducing valve is stuck shut; in this case jar around back head of intercepting valve with throttle open which will open it and in either case steam will pass to low pressure cylinder. In case engine should be without air for operating separate exhaust valve, and it was necessary to work engine simple, take the head off the separate exhaust valve; block valve open and replace the head. In all cases see that oil dash pot is full of oil and no leakage at stem packing, for breakage of any part of intercepting valve is usually due to too rapid a movement, and this slamming, account of lack of oil in dash pot.

V. C. RANDOLPH.

Salamancus, N. Y.

Bend the Twig.

We frequently hear the comment passed on an engineer or fireman: "That fellow does not know anything." From time to time, after years of service, a position is lost because of a fail-

argues more blame than can be attached to the man.

Hiring a new man for a fireman, placing him on the road and just teaching him sufficient to enable him to keep coal in a fire box and then leaving him to get his knowledge by experience, is very much on the same plan as putting a boy in school and allowing him to do as fancy dictates. If, on the contrary, when that young man was sent

reduction has been made in the operating force, from high to low. He has heard the expression so frequently: "The engine belongs to the company; when she is broken down they will furnish another; and, if a man lives up to the instruction book, he will never get over the road."

Whatever ideals he had formed on entering the service have been shattered, and by seeing the department that



ENGINE FOR MINHO DOURO RAILWAY OF PORTUGAL.

is the pivot of the system belittled, paid less in proportion to responsibility, curtailed more in necessities, and forced to greater extremes than any other department. Where these conditions exist the effect on men cannot fail but be detrimental to progress, and it is no wonder that men are not overburdened with compliments when called on to advance.

Mr. Official, when you are inclined to find fault with some of your older fire-

a condition of affairs existed where five or six trains run past what were really danger signals without paying the least attention, it seems to me that the officers in charge were the men to be justly punished. A careless condition of operating had grown up, as it always will grow up, where the discipline is loose, so that the real parties at fault were the officials who permitted violations of rules to become habitual, without check.

such a road would be disgusted to hear a suggestion made that they should take part in a scheme to demonstrate their own incompetency. Of course, it was different with officials of the Chicago & Northwestern Railway.

JOHN B. STONE.

Chicago, Ill.

Slipping Shut Off.

I have been on an engine when the engineer claimed that the engine was slipping, but before one had time to get one's head properly out of the cab, and see what was going on, he would shut off, and apply brakes. The trouble, such as it might be, was always found on engines when out of quarter, due either to sprung axle, or bent crank pin, and I think the peculiar sensation that was experienced on the engine which sounded very much like slipping, was due to some conflict existing in side rods, which had a jarring effect upon the engine when brought up to a certain speed. I do not think it possible for the wheels to revolve faster than they would revolve when in contact with the rail.

MASTER MECHANIC.

[The remarks made by our correspondent are quite to the point. The expression "slipping when shut off" is misleading. Many persons seem to think that under the circumstances described, the wheels are revolving faster than the

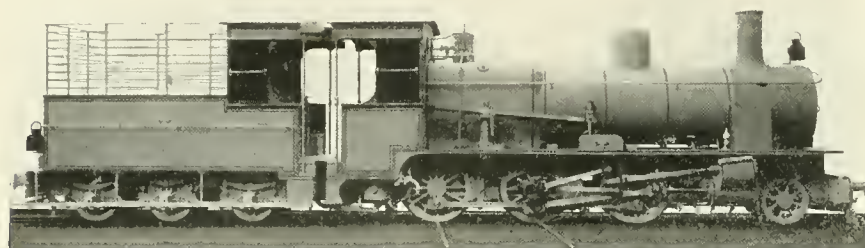

GERMAN MOGUL FOR ASSAM RAILWAY, BENGAL.

men and young engineers, temper your remarks with the thought: "Have I done all I can to improve him?"

You could get good work out of them, Mr. Official, and not have to use harsh measures, either, providing you commence at the right time.

It is at the start, Mr. Official, that you have the best opportunity to impress their minds with the facts that they are entering on an apprenticeship to fit them to take charge some day of life, limb and valuable property. You know, Mr. Official, if a man does not come up to a certain standard of excellence you can drop him out. The old adage, "As the twig is bent, so is the tree inclined," is a good one. Try it. The motive department of a railroad demands mental and physical force and you have a large amount of material to draw from. There is an attraction in road service that draws and holds men and that will assist you.

Recognize the fact that more and more is being placed on the engine. When you make rules carry them out personally, and see that others do it. Commence at the beginning and you will find an improved service.

TWIG.

Proving Their Own Incompetency.

On page 84 of your February number, you publish an account of how certain officials belonging to the Chicago & Northwestern laid a trap to show that their trainmen were in the habit of violating a certain rule by running past signals when the light was extinguished. They took a highly dramatic position to prove that their engineers habitually violated a rule, but do you think that the act was worthy of a real, practical railroad man? When

A good railroad officer, especially a division superintendent, on whose efficiency rests the safe movement of trains, checks loose practices in the bud. If he is the sort of man who looks upon rules as lines of defense for the company in case of accident, to be broken in the daily routine of getting trains over the road promptly, he has



MALLET 4-CYLINDER COMPOUND—SWISS GOVERNMENT.

no right to pose as a smart official when he detects men addicted to practices that they have been following all the time. There is miserably small merit in this species of detection.

Comparisons are odious, but imagine officials of the Chicago & Alton lying in wait to detect their trainmen violating the rules which the said officials are paid to have adhered to. Officials of

speed of the engine would warrant. As a matter of fact the wheels are not revolving as fast as they should for the speed of the engine, but the peculiar jarring effect produced very closely resembles the sensation caused by ordinary slipping under steam pressure, and has no doubt been mistaken for it. With throttle shut off, there is nothing to make the wheels spin round ahead of the

speed, but there is every reason with bent pins or twisted axle or engine out of quarter, to have motion of wheels slightly retarded, and a slipping sensation produced.—Ed.]

Slipping With Steam Shut Off.

Referring to the item in your January issue about slipping shut off, a few years ago I was running a ten wheel passenger engine, built by the Grant Works. During one of our trips the right side rod broke about 3 ft. from the back pin, the forward end of back piece went down into the ties and when the pin came over the rod, in order to get by, the engine was raised up and the strain was so great that it bent the back axle. I took the engine to the terminal and as the rest of the damage was light, the rod was welded and I took her on the run again the following day.

Everything went nicely until going down Yarmouth Hill, a grade on our line, about 60 ft. to the mile, the engine was drifting and had run about half a mile when I noticed her slipping very wickedly. My first impression was that she was getting steam; I tried throttle, and at the same time opened cylinder cocks, but cylinders were empty. This happened six times during the trip. I stopped the slipping each time by a light application of sand.

Never before had I heard or read of a case of this kind, but, taking into consideration our experience when the rod broke, I felt confident the back axle was sprung, and made my report to that effect, and when it was taken out it was found to be badly bent. My idea is that there is but one solution of this action. An engine badly out of tram through error in fitting up or a bent axle causes the rods to be on such a strain in passing the two points during the revolution that when they do get over they go with such force that they cause a rotary motion and each revolution adds to its own force until overcome by sand or otherwise.

I would like to hear from some of the boys who have had this same experience and who had made no report of it, simply because they could not locate the trouble. E. R. MOHR.
Washington, Ia.

Slipping Shut Off.

In answering the inquiry of superintendent of motive power of a prominent railroad in the January number of RAILWAY AND LOCOMOTIVE ENGINEERING, concerning the cause of an engine slipping after steam is shut off, I would say that too much or not enough counter-balance has nothing to do with it whatever.

Some time ago I read in RAILWAY AND LOCOMOTIVE ENGINEERING accounts of

engineers on different roads and their experience with their engines slipping after shutting off steam. I thought probably it might be indignation, caused perhaps by a poor quality of booze taken before starting out on trip. Shortly after reading these accounts I had the same experience on the Michigan Central, with a ten wheel engine or six wheel coupled, and no booze used of any kind before starting out on trip.

We had several cases following this one which puzzled the management for some time before they found the cause, which proved to be on account of engine being sprung out of quarter, and there is no doubt but that the cause of this is on account of side rods not being the proper length.

Solid end heavy steel rods if put up $\frac{3}{16}$ or $\frac{1}{8}$ in. too long or too short and a man obliged to pull down a wedge and move driving box ahead or back in order to get the rods on the pins and there will be trouble of this kind.

I do know for a fact that work on

Signals and Signaling.

BY GEORGE S. HODGINS.

(Continued from page 71.)

TRAIN ORDER SIGNALS—CONTINUED

A train order signal has been supplied to the Canadian Pacific Railway by the N. L. Piper Railway Supply Company, Ltd., of Toronto. It consists of a double semaphore on a single post which is placed near the center of the station, often on the slope of the roof adjacent to the track. This signal gives an indication of two kinds in both directions. In other words the enginemen of a train moving "down" the line and approaching a station have either the "stop" or the "proceed" indication before them. After he has passed the signal and has halted his train, he may look back, and he will see, in addition to the regular signal for the "up" line, a signal for his own or "down" train. The signal with this "back sight" for each direction makes it possible to draw past it and

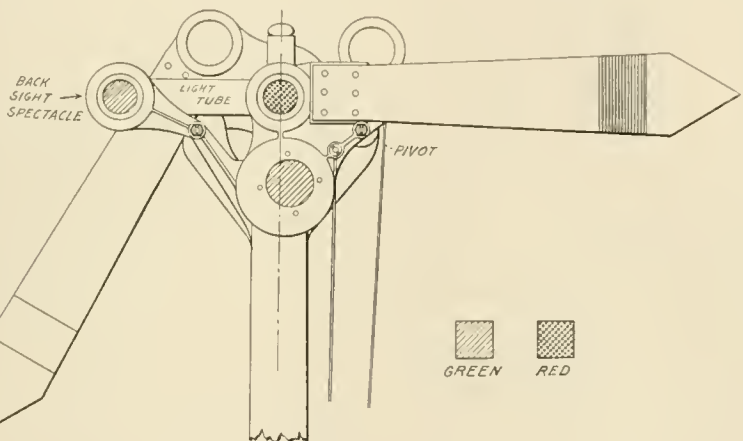

PIPER TRAIN ORDER SIGNAL WITH "BACK SIGHT."

hurry up repairs in our roundhouses have been done in this manner.

M. C. R. R. ENGR.

If you raise a circular valve a distance of one-quarter of its diameter off its seat you then have the valve full open and lifting it higher will not let more fluid pass through. For example, a valve 10 ins. in diameter has an area of 78.54 sq. ins. and the circumference is 31.416 ins., and $2\frac{1}{2}$ ins. is one-quarter of 10, and $31.416 \times 2.5 = 78.54$. So there you are.

The speed of a railway train in miles per hour can be found by counting the number of rails over which a car wheel passes in 20.4 seconds, because 20.4 seconds bears the same ratio to an hour that 30 feet, the length of a rail, bears to one mile. The wheel blows on the joints can easily be counted and the number passed in 20.4 seconds is the miles per hour.

yet at night look back and see what its indication is for the direction in which the train in question may be moving. In daytime the semaphore arms give the correct indication when looked at in either direction, but at night the regular signals and the "back sight" indication is given by an ordinary signal lamp placed on top of the post and having the two lenses for the "up" and the "down" lines covered by the ordinary spectacles of the semaphore arms. The two lenses which stand at right angles to the track are made to pour their light into two tubes which extend out perhaps eighteen inches from the signal lamp and terminate in two reflectors placed at an angle of 45° to the direction of the rays from the lamp, and thus light is again reflected parallel to the track, at a considerable distance from the illuminating flame. One of these reflectors shows light "up" and the other "down" the track. When the semaphore arm is horizontal, an auxiliary spectacle carrying a green

glass is interposed in front of the glass of the reflecting tube, and on looking back, after having passed the signal, the enginemen see a small green light to the left of the larger signal light, and they are therefore made aware of the fact that the order board is still against them or is not, as the case may be. If the signal assumes the "proceed" position, the smaller auxiliary light of the "back sight" becomes white. Neither of the "back sight" lights are shown through a lens. They are smaller and are not intended to be seen as far away as the train order signal lights, proper.

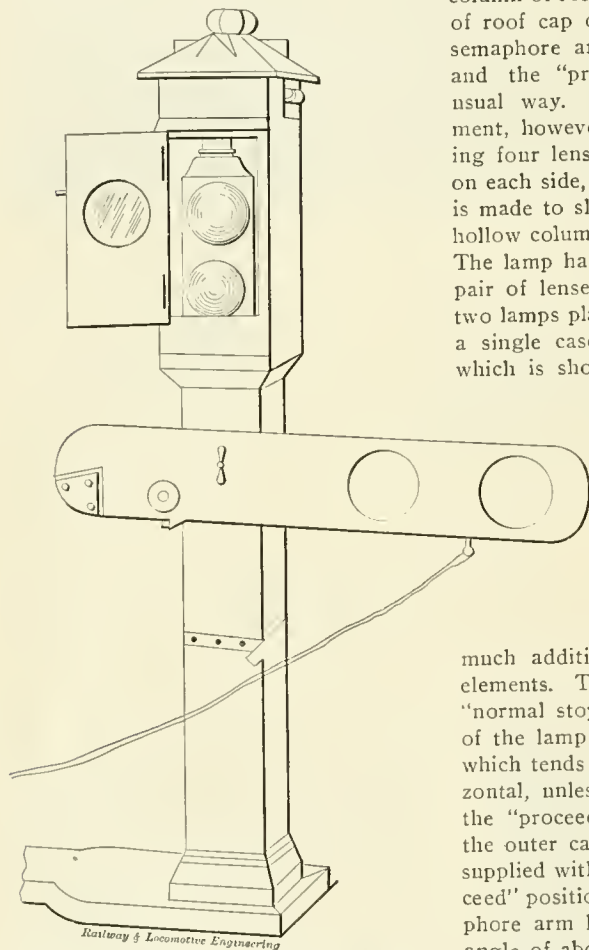

TRAIN ORDER SIGNAL, WITH LAMPS INCASED IN METAL POST.

On approaching one of these signals the enginemen see a bright red light for the night "stop" signal, or a large, strong green light for the "proceed" signal. They are also able to see the "back sight" signal which governs the movements of trains in the opposite direction. The advantage claimed for this device is that as the day indications are visible to the enginemen who have passed the signal, so the night signals will also be visible in the same way and that the men on the engine will be able by actual sight to check the report of the conductor as to the condition of the signal at night, when

he goes forward to the engine with his orders. The back sight, "proceed" color being white, and its "stop" indication being green, it is obvious that a red light will never be presented in either direction where it may be ignored. This is in accordance with the general principles of safe signaling which compels a stop to be made at a red light when displayed upon block, interlocking or train order signal equipment.

Another and earlier form of two position train order signal made by the same company is shown in the illustration. It consists of a light hollow sheet metal column of rectangular section, with a sort of roof cap on top. There is only one semaphore arm which gives the "stop" and the "proceed" indications in the usual way. The signal light arrangement, however, is unique. A lamp having four lenses, one red and one white, on each side, placed with the red on top, is made to slide up and down inside the hollow column which does duty as a post. The lamp has two burners, one for each pair of lenses, and is in fact practically two lamps placed one above the other, in a single case. When the little door, which is shown open in the engraving,

is closed the lamp is thus encased in a storm proof shell, which protects it from wind, rain and snow, and permits of its free up and down motion in all weathers. The lamp itself is of standard storm proof construction, so that the outside case is just that

much additional protection against the elements. The signal is operated on the "normal stop" principle with the weight of the lamp as a part of the mechanism which tends to keep the signal arm horizontal, unless purposely pulled down to the "proceed" position. The glasses in the outer case are plain, the lamp being supplied with parabolic lenses. The "proceed" position is assumed when the semaphore arm has been pulled down to an angle of about 60° and the white lens of the lamp pulled up to the level of the plain glass in the hollow column or signal post.

A form of train order signal used on the East Tennessee, Virginia & Georgia Railroad gives its "stop" or "proceed" indications in the daytime by means of both position and color. A suitable bracket bolted to the wall of the station building carries a red semaphore blade, surmounted by a lamp. The lamp turns on its axis as the arm moves from the vertical to the horizontal position and vice versa. Below the lamp hangs a cast iron case, if it may be so called. This so called case is composed of two flat parallel plates, between which the semaphore arm passes when in the vertical

position. The two flat plates are painted white and completely obscure the red semaphore arm when in the "proceed" position. When the "stop" position is assumed the white case turns about an axis and presents only two thin edges

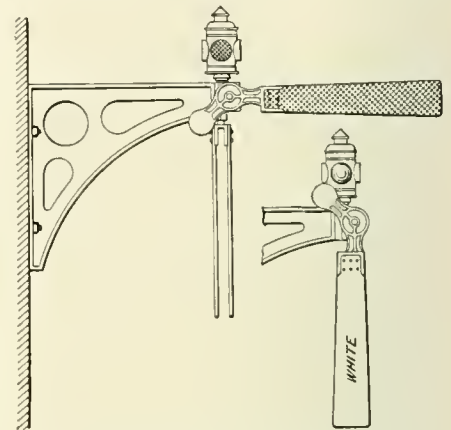

TRAIN ORDER SIGNAL USED ON E. T., VA. & GA., COLOR AND POSITION USED FOR DAY INDICATION.

to the view of the enginemen of an oncoming train, while the red semaphore arm is horizontal and the signal lamp above turns its red lens in the same direction. In this way the "proceed" position shows what resembles a white semaphore arm in the vertical position, while the "stop" shows a red signal arm in the horizontal position and only the two thin edges of the case hanging below it.

A primitive form of signal giving the right of entrance to a union terminal station is here shown. It consists of a mast with a cross piece at the top carrying pulleys from which hang chains used in raising or lowering signals. The signals themselves consist of large egg shaped globes of tin, painted vermilion, below which, at night, red lights are displayed. The method of operation is approximately as follows: One ball or one red light at the mast head allows X. & Y. Railway trains to enter the passenger station. Two balls or two red lights at the mast head permits trains of the A. B. C. division to cross the freight tracks in the yard and enter the station. Three balls or three red lights will allow trains on the V. & W. freight tracks to run in either direction to cross the A. B. C. division tracks. Absence of all signals stops all east bound trains outside the limit sign. At the other end of the station similar indications are made to govern the entrance of trains moving in a west bound direction. These signals while using colored balls and colored lights nevertheless depend upon position only for the indications given.

An ingenious train order signal used on the Lake Shore & Michigan Southern Railway consists of two semaphore

arms joined together at the pivot point, and no matter how they may be turned they make a right angle with each other. This is Gravit's railway signal, sometimes called the "bootjack." The arms are capable of making a complete revolution about the pivot point.

When the arms are in the position shown in the first illustration, in which they resemble the rafters of a roof, both "up" and "down" trains may "proceed." When the arms are as shown in the lower half-tone, with one arm vertical and the other horizontal and pointing toward the station, the "stop" signal for the "up" line is given, while the "down" line has the "proceed" signal displayed. Similarly when the "up" line signal is at "proceed" and the "down," at "stop" the arms would

what is the actual indication given and whether or not the signal lamps are burning.

This signal depends upon position for the day indication, and it may be ob-

Slipping When Shut Off.

Page 27 of the January, 1904, issue of RAILWAY AND LOCOMOTIVE ENGINEERING, in re slipping with steam shut off. In 1893 a 4-6-2 passenger engine on a western road slipped badly when drifting. Investigation showed it was caused by engine not being properly quartered.

In 1901 another case of the same nature happened on a 10-wheel passenger engine on the G. N. Ry., Mont. Div., cause, the engine not properly quartered.

In my travels I have found others who have run up against the same trouble in different parts of the country. This is my past experience and knowledge of this cause.

G. MORGAN MILLER.

San Luis, Potosi, Mexico.

The output of the Baldwin Locomotive Works for 1903 was the largest in the history of that establishment. It comprised a total of 2,022 complete locomotives. In addition to these, duplicate or repair parts were furnished, equivalent to about 250 complete locomotives additional. Of the completed locomotives, 1,966 were for service in the United States, and 56 for use in the following countries: China, Costa Rica, Cuba, Mexico, Japan, Newfoundland, Yucatan, England, Hawaii, Brazil, British Columbia, Nicaragua, Peru, and Porto Rico. Compound cylinders were applied to 300 locomotives, while 85 locomotives were operated by electricity, and 6 by air. This large output represents the united efforts of a weekly average of 14,720 men working 10 hours per day, some on day turn and some on night turn. The product of the nine preceding years was as follows: 1894, 313; 1895, 401; 1896, 547; 1897, 501; 1898, 752; 1899, 901; 1900, 1,217; 1901, 1,375; 1902, 1,533.

Considerate Newspaper Man.

The New York *Globe* is responsible for the following: "Representative Brownlow, of Tennessee, is a nephew of Parson Brownlow, who was a national figure thirty years ago. He is the editor of a country paper when he is not working in Washington, and began life as a reporter on his uncle's paper in Knoxville. In his early newspaper days he asked the superintendent of a little railroad for an annual pass. The railroad man wanted to know on what ground. 'I don't see that we owe you anything,' he said; 'you never say anything about our road in your paper.' 'That's the very reason I'm entitled to it,' replied Brownlow. 'It's the greatest kindness I can show.'"

All the theory in the world will not teach a person how to drive a nail. There are many things that can be learned only in the same way as we learn to drive a nail, which is by practice.



GRAVIT'S TRAIN ORDER SIGNAL "PROCEED" BOTH DIRECTIONS.

jected that these signal arms may actually assume one of two different positions and yet make the same indication. In our illustrations the "down" line "proceed" indication is given by the arm governing that track being at one time at an angle of 45° to the post, and subsequently parallel to it, and while there may not be any serious ambiguity in actual operation, on a well regulated line yet in railway signaling the broad and fundamental principle in which actual accuracy is the end sought should always be kept before the minds of future inventors and designers



GRAVIT'S TRAIN ORDER SIGNAL "STOP" FOR WEST BOUND, "PROCEED" FOR EAST-BOUND TRAINS.

of railway signals. This principle may perhaps best be put into words by using the biblical injunction, "But let your communication be yea, yea; nay, nay."

(To be Continued.)

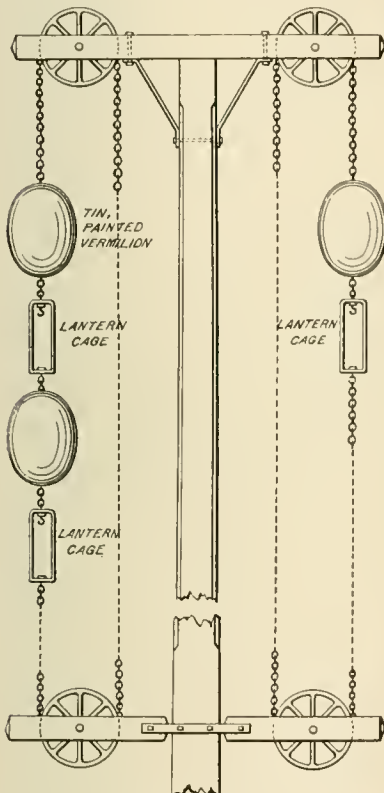

OLD BALL AND LAMP SIGNAL AT TERMINALS.

stand with the horizontal one pointing away from the station building and the other vertical. When both lines are blocked and orders are held for trains going in both directions the signal arms are both revolved to positions above the post, making the outline of the letter Y, with the signal post as the upright line. In this form of signal there is a lamp case below the signal arms. Within the lamp case, lamps are raised and lowered so as to shine through various spectacle glasses, and so give corresponding indications at night. The lights are so arranged to shine through spectacles placed so as to be visible by the operator in the station and he is therefore able to see

Railway and Locomotive Engineering

A Practical Journal of Railway Motive Power and Rolling Stock.

Published Monthly by

ANGUS SINCLAIR CO.,

174 Broadway, New York.

Telephone, 984 Cortlandt.

Cable Address, "Loceng," N. Y.
Glasgow, "Locanto."

Business Department:

ANGUS SINCLAIR, President.
FRED M. NELLIS, Vice-President.
JAMES R. PATERSON, Sec'y and Treas.

Editorial Department:

ANGUS SINCLAIR, Editor.
F. M. NELLIS,
GEO. S. HODGINS, } Associate Editors.
JOS. A. BAKER,

Advertising Department:

Eastern Representative, S. I. CARPENTER, 170 Summer St., Boston, Mass.
Western Representative, C. J. LUCK, 1204 Monadnock Block, Chicago, Ill.

British Representative:

THE LOCOMOTIVE PUBLISHING CO., Ltd., Amen Corner, Paternoster Row, E. C., London.

Glasgow Representative:

A. F. SINCLAIR, 7 Walmer Terrace, Ibrox, Glasgow.

SUBSCRIPTION PRICE.

\$2.00 per year, \$1.00 for six months, postage paid to the United States, Canada and Mexico. For other parts of the world, \$2.50 or ten shillings. Single copies, 20 cents. Remit by Express Money Order, Draft, Post Office Order or Registered Letter.

Mailing address can be changed as often as necessary—always give old and new address, and if you subscribed in a club, state who got it up.

Please give prompt notice when your paper fails to reach you properly.

Entered at Post Office, New York, as Second-class mail matter.

Copyright by Angus Sinclair Co., 1904.

For Sale by Newsdealers Everywhere.

Boiler Explosions.

In a report on boiler explosions made to the Railway Master Mechanics' Association the sentence occurs: "Explosions occur from over pressure; it matters not whether the whole boiler or a portion is too weak to resist the pressure." That sentence was written in 1869, and all the years that have passed since that time with the vast experience gained concerning boilers, has corroborated the great truth expressed. At that time numerous wild theories were rife, to the effect that boiler explosions were frequently due to some mysterious agency that human care could neither provide against or control. The good sense displayed by the Master Mechanics' Association on this question did much to disseminate rational views concerning boilers, and very few people now believe there is more occult cause for the explosion of a boiler than there is for the breaking of a valve stem. We are sometimes asked to discuss theories concerning mysterious causes of boiler explosions, but we think it would be waste of printers' ink.

We decline to publish irrational theories about boiler explosions, because they do not have a place in the gospel of

sound engineering, and we are apprehensive of our readers falling into heretical beliefs on a subject so important to their worldly welfare. Our motto is: "Keep the steam gauge correct, do not meddle with the safety valves and see that vigilant inspection is made to detect broken stay bolts. It is a safe plan to see that there are two gauges of water in the boiler. Leaks about the boiler are evidence of weakness, and every case of the kind ought to be carefully examined. The usage to which a locomotive boiler is subjected in ordinary service is sufficient to bring about deterioration, which will have a destructive effect if not properly remedied. The frames of the locomotive are regarded as two girders, and are supposed to be strong enough to bear the weight of the boiler and all that is on it without yielding, but this is not entirely correct.

The boiler and frames are secured to each other by the expansion braces at the fire box end, the cylinders at the front end, and by belly braces at intermediate points along the barrel of the boiler. The boiler and frames being bound to each other in the manner they are, it is the supposition that that combination is self-sustaining, but such is not the fact, as the boiler itself indicates. Keen observers, who are responsible for the care of boilers, know that the boiler yields by its own weight when it receives heavy shocks. Where the belly braces are riveted to the barrel of the boiler, which has run any length of time, it will be found that around the edge of the rivets, inside the boiler, the sheets are grooved. If these braces are not riveted, but are brought up to the boiler so as to fit around the under side, the working of the engine will show the chafing of the braces on the boiler, indicating the resistance it must offer.

Another sign of destruction is the small cracks that take place in the upper side of the throat sheet. These are generally supposed to be effects caused by some obstruction to the expansion of the boiler. When the upper corner stay bolts and others next to the flange of the throat sheet are found leaking, it is evidence of the strain put upon them when the boiler bends up or down. There is some spring between the flange and these stay bolts, but little or none in the upper sides, where the cracks take place. This spot may be looked upon as the fulcrum of the lever, as it receives the direct crushing effect, alternating as the boiler bends. The weight of the barrel and its contents, with the cylinder bolted to the smoke box, acts like a weight on the end of the lever, keeping that end of the boiler down and binding it to the frames.

These destructive strains mentioned may be regarded as mechanical while at the same time there are still some serious strains caused by the unequal ex-

pansion and contraction, due to heating and cooling. We have heard it said that certain boiler explosions were due to the act of God, but as a rule the neglect of inspection and proper reports by the men in charge are the real origin of the disaster.

As a rule, injustice is done to the man in charge when a boiler explodes. A worn out boiler, that has received no systematic inspection or repairs, but has held together with mysterious persistency, goes to pieces one day, and all those who are really responsible for the death trap being where it could do harm shout with one accord: "The water must have been low." This cry of low water is nearly always raised as a fog to hide the real culprit. Hot plates are weaker than cool ones, and boiler explosions have resulted from overheated furnaces; but cases of this kind have been rare compared to those that have resulted from broken stay bolts and corroded sheets.

There is some excuse for people thinking that something mysterious must have been at work to tear a boiler into pieces. The boiler has been working under the same pressure day after day without showing any signs of distress, and it suddenly goes to pieces without any warning. That seems strange when the whole particulars of the case are not properly understood. Although no weakness has been apparent, there have been stay bolts breaking gradually, or there may have been a crack on the edge of a seam, working deeper and deeper with every infinitesimal bend due to change of pressure or physical shock. A time comes when the stayed surface or the cracked plate becomes too weak to resist the pressure within, and the explosion is too sudden to give warning. The people sometimes found who allow a leaking hollow stay bolt to be plugged or who patch a crack without finding out the extent of the weakness, criminally neglect fair warning.

Unexpected and inexplicable failures or breakages are quite common in all lines of industry, but they do not attract so much attention as boiler failures, because the effects are not so destructive or conspicuous. A link in the chain of a crane breaks under a lighter load than it lifted two hours before. A crank shaft breaks, not with the engine working at its maximum power or speed, but under comparatively light duty. A locomotive axle breaks when the engine is jogging along at a quarter of the speed made the day before and sustaining much lighter shocks. Every man familiar with the handling of tools or familiar with appliances subject to shocks and severe strains, remembers cases of unaccountable breakage. These things are strange, but few people believe that Satan or some other evil power had a hand in the failure. They are not sufficiently strik-

ing to engender superstition. It is only when a boiler explodes that mysterious agencies are thought of. The most careful investigation may fail to identify the broken stay bolts, the cracked sheet, the corroded seam or brittle plate, but those who are given to reasoning between cause and effect will certainly abide in the faith that one of these or some other natural cause has brought the boiler to grief.

A series of experiments with boilers were made on the United States Government years ago that gave very valuable data about boiler explosions. One of the experiments was with flat stayed surfaces that would very well represent side sheets or crown sheets secured by stay bolts. Heat was applied with plenty of water over the heating surface until the vessel exploded from over pressure. Dr. Coleman Sellers, who was present, describing this explosion, wrote: "It was fired up, and when the steam reached 125 pounds we left the boiler and retired to a safe place. In about five minutes, with about 180 pounds gauge pressure, it exploded. The sheets went out in the form of dishes, each part where the stay bolt was presenting an indentation like a mattress. Every stay bolt was drawn out of its hole. No stay bolt was injured in the slightest degree on its thread, but every hole, from which a stay bolt was drawn, was enlarged sufficiently to allow the stay bolt and its head to come out."

This is information worthy of consideration by people who act as experts before the courts when boiler explosions happen. The writer was present at a law suit once over an exploded boiler, and the attempt was made to prove that the accident was caused by low water. We heard several so called experts testify that the sheets must have been hot because the stay bolts were pulled through the sheets without tearing off the threads.

The belief exists among many people that a boiler will not explode so long as it contains a good supply of water. Properly conducted experiments have repeatedly disproved the correctness of this theory. An easily made experiment is: Take a piece of steam pipe 3 ins. diameter and 3 ft. long. Screw a steam tight cap on one end and put water in the pipe till it is $\frac{2}{3}$ full. Then drive a pitch pine plug into the other end until it is within 3 ins. of the water, giving room for expansion. Put the pipe on a bright fire and get out of the way. For an explosion will follow in a few minutes. If all the water was converted into steam there would be no violent explosion. The violence of a boiler explosion is directly in proportion to the amount of water ready to flash into steam when a rupture is made great enough to suddenly release the pressure.

Another unfounded belief about steam

boilers is that injecting feed water upon heated plates is likely to cause an explosion. Iron and steel boiler plates do not act that way, although a hot cast iron plate might crack when drenched with water. If a piece of iron or mild steel is made red hot and quenched in the coldest water it will be annealed instead of cracked. For this reason there should be no hesitation in putting on the feed when the water in a boiler is found to be low. The most harm that can be done will be that the sudden shrinkage of the sheets will cause the seams to leak.

The Pennsylvania Railroad Company, years ago, carried out a series of experiments with locomotive boilers that prove most of the statements made. A locomotive which was condemned to be scrapped, was run out on a side track in the woods near Altoona, and experiments made upon it. The plan was to fill the boiler with water, raise a high pressure of steam, then run off the water until the crown sheet was exposed, permit it to become red hot and then pump cold water into it, to find out the effects. In the first experiment the boiler exploded before they had time to blow off any of the water. They then took another old engine whose boiler stood the steam of unusually high pressure. After steam was raised the water was drawn off until it was below the crown sheet. They waited long enough for the crown sheet and the upper part of the fire box to become red hot, then they forced a supply of water into the boiler by means of a powerful fire engine, and nothing happened except that the seams leaked and the steam went down. This was repeated several times, always with the same result. The boiler was damaged by the overheating, but no accident happened.

Rating Machine Tools.

The strenuous tendency in railway machine shop work to-day is well illustrated in two papers recently read before the Western Railway Club. One paper describes a Plan to Establish a Machine Rating in a Locomotive Machine Shop with Special Reference to New Tools. The other is on Machine Tools and High-Speed Steel. Both papers display a sentiment of discontent because machine tools are not worked up to their highest capacity, and because other tools are too weak to endure the greatest cut that high-speed tool steel can make. We do not know if these papers represent the prevailing progressive sentiment of railway master mechanics and general foremen, but if they do there is likely to be greater friction in the near future between shop workmen and their bosses than has ever been experienced in the past. The papers breathe the spirit of always rushing production at its highest ve-

locity and taking out of the workman the full pound of flesh.

At the Exposition of Railway Appliances, held in Chicago in 1883, an engine lathe was shown at work which displayed extraordinary capacity for slicing off metal. The maker of that lathe boasted that it had double the capacity of lathes of similar size common twenty years before. This high-capacity lathe marked the pace for other makers to follow, and within a very few years it had become standard. Now users of machine tools are again asked to double the capacity of their product because steel of greatly increased cutting properties has been put upon the market. The feature that was chiefly instrumental in effecting the radical improvement on the old lathe was strengthening the parts. This was generally done so that by improved distribution of the metal increased strength was obtained with small increase of weight. Improved workmanship also helped in producing a superior tool. The indications are that machine tools, such as lathes, planers, boring mills and slotters, the tools subjected to the most strenuous forcing are as rigid now as they can be made with the weight of metal employed, and that if a further strengthening process must be undertaken that a radical re-designing of the tools is necessary. It may pay railway companies to throw away their old tools and purchase new designs to render high-speed steel entirely efficient, but we doubt it.

The proposal made at the Western Railway Club of rating machine tools as locomotives are rated is a very radical suggestion likely to bring forth active opposition from the machinists doing the work. It is not a fair day's work that is asked, but the demand is made that workmen should rush their operations all day as vigorously as an athlete endeavors to win a race or defeat his opponent in a fight. There is more agitation among certain petty railroad officials to make the men under them beasts of burden than there is among any other industrial class. We caution railroad officials against any active move to put such an arrangement as rating tools into force. Engine rating has not been an unqualified success, and it has led to much heart burning that tended to antagonize officials and trainmen. It was of much greater importance to railroad earnings to have a locomotive work to its full capacity than it is to increase the work of a machine tool, yet the tendency of petty officials was to use their brief authority to overwork the engines. That would happen in a more iniquitous degree in the rating of machine tools, a consideration which should induce master mechanics to pause before they begin the practice of rating machine tools.

Motor Cars for Surface Railways.

The recent terrific speed made by automobiles on the beach at Ormond, Florida, has attracted the attention of the whole world interested in transportation problems, and railroad managers are naturally anxious to find out to what extent the power derived from the combustion of gasolene might be employed in moving railroad cars. The intense velocity attained by a light car carrying a very light load was a good object lesson, but we think that better examples of the efficiency of gasolene motors are to be seen daily in our large cities where heavily loaded wagons are to be found moving through the crowded streets without difficulty or delay. The motors which drive a wagon carrying six or seven tons over the rough streets of cities ought to be doing a good deal of work on light railways and on suburban lines where few cars per hour are run. A little progress is making in applying gasolene motors to inspection cars and one maker is offering to furnish motor cars for that purpose, but railway people have not yet wakened up to the high utility of this power.

The engineering department in charge of German railways appear to be more alive to the possibilities of the motor car than those of any other country. A French technical paper recently published illustrations and descriptions of a motor car used on the Wurtemberg State Railways which carries 56 passengers and weighs 27,500 pounds or about 500 pounds per passenger, which compares favorably with suburban cars on steam railways, and is little different from the dead weight of a touring automobile. That car is capable of maintaining a speed of 22 miles an hour and a gasolene tank holding about 30 gallons will supply power to run the car 217 miles.

Some British railways have been experimenting with gasolene motor cars for their light suburban traffic with promising results. They expect by running individual cars at frequent intervals to conserve part of the business which electric car lines are taking away. Many of our steam railroad companies could well afford to try the experiment of introducing motor cars in districts where suburban traffic is light.

It is my experience with machinists that they are always hungry after something to read if it refers to their immediate vocation, and brings knowledge not included in skill. A workman will often resent a thing which looks like instruction in something he thinks he knows all about, but will grasp with avidity at something regarding the material he works with, or the tools he uses. Of course, such reading is mostly done, and

mostly appreciated by the young fellows who are priming for the future. If owners of shops will keep one eye open for such tendencies they will find it an excellent index to character, and a pointer towards an excellent plan of encouragement which will repay ten fold.

Standardization.

Standardization does not exactly stop progress, though it certainly has a tendency to check the rapid or premature adoption of every new device which comes out. A good example of this is to be found in the M. C. B. vertical plane coupler.

When automatic couplers were first insisted upon by the Interstate Commerce Commission any number were invented which, although they filled all the requirements of the law, were not interchangeable with other couplers which also fulfilled the requirements of the law. When the M. C. B. Association decided in favor of the vertical plane coupler, their action practically consigned to the scrap pile a good many otherwise serviceable types, and many inventors were found to have spent their energy without hope of success.

In turning the attention of inventors and manufacturers exclusively to the vertical plane type, and in thus choosing a guiding principle rather than a particular device, they have conserved energy which would otherwise have been expended uselessly, while at the same time they did not seriously hamper inventive genius. This is proved by the larger number of couplers on the market to-day. By doing what they did, the Association practically placed a target before the firing party, and the result was a saving of intellectual ammunition, and, of course, fewer shots went wild. The skill of the inventor and the energy of the manufacturer have been directed to the improvement of interchangeable couplers which are all variations on the one type.

The New York *World* gives an example of a conservative policy with regard to the maintenance of standards. It says: "A curious instance of standardization is furnished in the German Navy. It is the present policy of the Kaiser to build warships in groups of five exactly alike. Suppose two of the five to be out of commission when a war breaks out. The experienced men of the three active ships are distributed among the five and are at home and able to teach the greenhorns of the new drafts. So valuable is the principle of uniform group building held to be that the German Admiralty has even rejected improvements in the latter vessels of a group, holding homogeneity more important than improvement handicapped by variation from the group type."

New Railway Policy in Canada.

There has been some change in the attitude of the Government of Canada to the railways of the Dominion, and the last session of parliament saw a new railway act passed. The Railway Committee of the Privy Council is now superseded by the Canadian Railway Commission composed of three members appointed by the premier, with the approval of the Governor General.

The new commission somewhat resembles the British Board of Trade, but deals exclusively with railway matters. Its authority extends even to the details of railway management, and the situation thus created practically amounts to the closest government supervision. The control of the commission rests with the cabinet which latter may rescind any act of the commission. The cabinet in Canada is, however, directly responsible to Parliament. The Canadian Commission is designed to be an impartial body, outside of, and above direct party influence. In dealing with cases which come before it, the commission will not act in the capacity of prosecuting attorney; it will act as judge, and its findings will have to be recognized and its orders obeyed throughout the whole of Canada.

It is possible to form such a commission by act of the Dominion Parliament, because in Canada there is no such thing as "state rights." The principle upon which the provinces of Canada federated, and became the Dominion is different from that of the United States. In Canada the provinces on coming together, gave to the Federal Government the largest share of authority, each province retaining only certain designated powers. The work of the new railway commission will be watched with much interest. The Hon. A. G. Blair, formerly minister of Railways and Canals, is chief commissioner.

Bells and Whistles.

We recently came across an editorial headed Bells and Whistles, in one of the many daily papers which come to the office. The writer of the editorial pointed out that the builders of modern churches usually consider the church bell unnecessary, and make little or no provision for a bell. The "church-going bell" he regarded as having outlived its usefulness, but expressed the hope that the bell would yet be retained because, as he said, "a well-tuned bell gives joy to the Sunday morning, and, as for chimes, there is little music that brings more pleasure to the populace as a whole."

The church bell has outlived its usefulness, it is true, in a community where nearly everybody carries a watch and where clock towers are scattered here and there in a city of any size, but a well-tuned bell has a charm all

its own. When we come to consider the factory whistle or the whistle used on many of our large railway repair shops, we are compelled to say that in many instances the whistle has outlived its usefulness and has no charm at all.

We remember, years ago, that a certain ferry company, which operated boats between a city and a neighboring island, used to cause its boat whistles to be blown many times, with long blasts, before the boats left the wharf. Whether those in authority imagined that they increased their traffic by whistling is not certain, but they certainly succeeded in creating a nuisance, and this was, in time, suppressed by law, and those who want to go to the island have to go there now without being allured by the shriek of a steam whistle.

To-day, important trains leave a terminus, and steamships depart, without unseemly noise, and yet, as a rule, the factory or locomotive shop whistle is blown long and loud before the hour for work, at the hour of work, and for noon hour, before and at one o'clock and at six in the evening. There seems to be a sort of hazy idea in the minds of many that a prolonged and strident blast of a whistle brings men in on time who otherwise would be late, while the fact is, that those who intend to work and those who do not, pursue their course irrespective of the sounds from the whistle. A whistle blown from three to four seconds is all that is needed to call attention to the fact that the hour has struck, because everyone is on the lookout for it and is ready before it blows. Nevertheless, there are many places where a shop whistle is allowed to destroy the comfort of a large section of the community and to waste steam for so long as a quarter of a minute each time it is blown and nobody can tell what earthly good all the hideous noise does.

Book Reviews.

The Metric Fallacy, by F. A. Halsey and S. S. Dale. Publishers, D. Van Nostrand Company, New York. 1904. Price, \$1.00.

This book has a very satisfactory and self-explanatory title. It is really two discussions of the same topic. The first 137 pages is on the Metric Fallacy, by Mr. Frederick A. Halsey, and the rest of the book, 94 pages, is on the Metric Failure, and is written by Mr. Samuel S. Dale. Mr. Dale's part of the book refers to the failure of the metric system in the textile industry.

The book is the outgrowth of a paper read by Mr. Halsey before the American Society of Mechanical Engineers in December, 1902. The points raised in

the discussion have been rewritten and placed in their proper position. Many of the arguments are reproductions of papers previously published by the authors.

Mr. Halsey claims that the Anglo-Saxon nations are the only ones that have ever dealt with the subject of weights and measures in a rational manner. He gives the pro-metric argument in brief, and the anti-metric argument also in brief in the first two or three pages of the book, and he then very carefully discusses the errors and misrepresentations by the metric advocates and reviews the persistence of old units in the various European countries. A table occupying 9 pages and compiled by the State Department at Washington, giving the non-metric units used in metric countries is given.

The idea that the metric system is the great desire of all nations does not get any support from Messrs. Halsey and Dale. The book is one which should be widely read and should be of special interest to those who are still halting between two opinions. The authors believe that for those engaged in engineering work, and in the manufacturing industries the compulsory introduction of the metric system would be little short of a calamity, and they give facts and figures and chapter and verse in support of their views. They also think that the confusion which would be introduced into the simplest business transactions of all sorts of people all over the country would far outweigh any advantage which might be secured by the introduction of the metric system.

Ancient and Modern Engineering and the Isthmian Canal, by William H. Burr, C.E. Publishers, John Wiley & Sons, New York. 1902. Price, \$3.50; postage or expressage 27 cents additional.

This book, by the professor of civil engineering in Columbia University, is a comprehensive statement of technical and non-technical matters, connected with the subject. The first part, which relates to ancient engineering works, gives one an interesting glance at the efforts of early engineers to construct substantial and enduring monumental and useful works. The great pyramid, the temples, aqueducts, military bridges, Roman roads and harbors, are described and illustrated with halftones and line cuts. Part II is devoted to modern bridges; Part III to water works for cities and towns; Part IV to some features of Railroad Engineering; Part V deals with the Nicaragua Route for a Ship Canal, and Part VI takes up the Panama route.

The work is the outcome of a course of six lectures delivered under the auspices of Columbia University, in New

York, at the Cooper Union, in February and March of 1902. The book has 473 pages, and is profusely illustrated.

Electric Traction, by John H. Rider. Publishers, The Macmillan Company, New York. 1903. Price, \$3.00.

This is a practical hand book on the application of electricity as a locomotive power, written by the chief electrical engineer of the London County Council Tramways. It contains, with index, 452 pages, and has 194 illustrations. There are fourteen chapters which, with an introduction, deal with generating plant, switch gear, distribution, motors, controllers, rolling stock, permanent way, overhead systems, conduit systems, surface contract systems, accumulators, combined lighting and traction stations, and electric railways; an appendix deals with the Board of Trade Regulations (English) and specifications of posts and brackets.

Testing of Electro-Magnetic Machinery and Other Apparatus, by B. V. Swenson and B. Frankenfield. Publishers, The Macmillan Company. 1904. Price, \$3.00.

This book is concerned with direct currents, and gives at the beginning the nomenclature of the subject in tabular form, a list of references and a list of experiments. The book itself opens with some preliminary remarks on general methods, etc. The next chapter is on Instruments, in which the various kinds of indicating instruments are classified, by considering the principles upon which they operate. The chapter following is devoted to the consideration of experiments, 96 of which are given. They are written for easy reference, the subjects being noted in the index at the back of the book. Appendix A takes up Shop Tests, and Appendix B, Standardization Report of Committee of A.I.E.E. The authors are well known in the electrical world; Mr. Swenson is connected with the University of Wisconsin and Mr. Frankenfield is with the Nerst Lamp Company.

The Treatment of Steel is the title of an interesting little book of 156 pages which is a compilation from the publications of the Crescent Steel Company on heating, annealing, forging, hardening and tempering, and on the use of furnaces with a chapter on hardening and tempering from a work by Mr. Geo. Ede, of the Woolwich Arsenal, England. The book is got out by the publication department of the Crucible Steel Company of America, Pittsburg, Pa.

"There are plenty of men," says Josh Billings, "who cannot to save their lives make a boys' wind mill that will turn, that do not hesitate for a minute to tell how to improve a steam engine."

QUESTIONS ANSWERED.

(15) M. F. P., Bradford, Pa., writes:

In an argument with a friend, he claimed that an engine to be "direct," must not only have a direct valve travel, but have a valve travel direct and equal to the throw of the eccentric. I claim this is not necessary to make a "direct" engine. Who is right? A.—You are right. The expression, direct acting valve gear, refers to the motion of the valve with reference to the motion of the eccentric rod. If, when the eccentric rod moves forward, the valve also moves forward and vice versa, then the valve gear is said to be direct, or the connection is said to be direct. This may be done by attaching the eccentric rod to the valve stem or by the interposition of a rocker with both arms on the same side of its center. Indirect valve gear means that when the eccentric moves forward the valve moves backward. This is usually done by the use of a rocker with one arm above and one arm below the center of the rocker. The words "direct" or "indirect," when applied to valve gear, do not have any reference to the throw of the eccentric or the length of valve travel.

(16) C.A.D., Memphis, Tenn., writes:

Will you kindly inform me if there is any chemical process to put coal through to ascertain the quality of the coal and the matter and properties it contains? A.—There is no simple chemical process which could be used in a round house by a foreman to test the quality of coal. The accurate testing of coal is intricate and difficult. Some people have tried to burn samples of coal on a small hand forge to find if the coal would clinker or not, but the testing of coal to be of any real value would have to be done by an expert with suitable apparatus.

(17) A.M.S., Topeka, Kansas, writes:

Some railroad men were talking about whistles and several stories were told of who invented the first whistle for locomotives and where it was first applied. We decided to send the question to you. A.—The bell steam whistle was invented by an engineer named William Stephens in the Dowlais Iron Works in Wales about 1830. It was first applied to a locomotive by Edward Bury, one of the early English locomotive builders.

(18) R. Y., Chicago, Ill., writes:

A question which I expect to be asked at a coming examination is; describe the course followed by steam from the boiler to the cylinders and then out to the atmosphere. Can you give me a clear description? A.—If you have Sinclair's Locomotive Engine Running, or our chart showing details of a locomotive, take the engraving that shows cross sec-

tion of boiler. In the dome you will see a stand pipe with the throttle valve closing the opening. When the throttle valve is opened the steam passes into the pipe, then traverses the dry pipe to the branch pipe in the smoke box. This it follows to the steam chest where the valve admits it into the cylinder. After doing its work there it passes through the cavity under the valve into the exhaust pipe which leads it through the smoke stack into the atmosphere.

(19) F.E.S., Bloomington, Ill., writes:

Please explain what is meant by the spread of the cylinders? A.—The spread of the cylinders of a locomotive is the distance between the centers of the cylinders when measured across the front, that is by a line parallel to the direction of the ties and at right angles to the rails, this is the spread of the cylinders. The word "spread" is often used to denote the distance between the centers of similar parts; for instance, if the distance between the leading and the trailing wheels of a truck, measured parallel to the rail, should be five feet, it is correct to say five feet is spread of the truck wheels.

(20) R. B., New York, asks:

What is the effect of lead, lap and inside clearance? A.—Lead is the opening of the steam port when the piston is at the beginning of its stroke. The advantage of lead is that it permits the steam port being wider open for the admission of steam when the piston begins its stroke than would be if there was no lead, and as it also opens the port a little before the piston reaches the end of its stroke, it provides a cushion of live steam to help take up the motion of the piston. Lap, or, more exactly, outside lap, is the portion of the valve which overlaps the steam ports when the valve stands in the central position on the valve seat. A valve with lap has an earlier cut off than one which has not, and the steam confined in the cylinder is given a certain amount of time to expand before the exhaust takes place. Inside clearance is the difference in the width of the exhaust cavity of the valve and that measured over the inner edges of the steam ports. The effect of inside clearance is to cause the release of the steam to occur earlier than it otherwise would and compression to take place later. We would advise you to get hold of some elementary treatise on valve motion, and go into the whole subject; it is very interesting. Our list of books will show you how to make a beginning.

(21) D. F. G., Chicago, writes:

Please tell me the size of double tips to run in an 18 in. cylinder engine, with $4\frac{1}{2}$ in. single tip. Will it be one half

the size of the single tip? What does the indicator show as to back pressure with single and double tips? A.—This involves the old question as to the relative areas of circles, which can be answered by reference to a table of areas of circles in any engineering pocket book. In this case a single tip $4\frac{1}{2}$ ins. in diameter would be equaled by two tips each about $3\frac{1}{16}$ ins. in diameter. You can tell from the indicator diagram whether the engine has single or double tips where the speed is low and the work heavy as in starting the train. If the pipe is single, the exhaust steam will partly back down the other pipe, even though the tip is larger than the choke, as in the M. M.'s partition exhaust pipe. It will do this even if the one tip is equal in area to the areas of the two tips, but the effect will be less marked for every increase in the size of the single tip. The single tip is shown by a slight hump in the exhaust line, which entirely disappears as the speed increases. The double exhaust does not show a defect of this kind, but as a general rule the smaller size of tips used with the double arrangement has a tendency to raise the whole exhaust line. The higher exhaust line is not so striking as the hump, but the higher exhaust line when it does occur is worse and it is very likely to be overlooked.

Engines for Louisville & Nashville.

The Baldwin Locomotive Works are building 55 consolidation locomotives for the Louisville & Nashville. These engines have cylinders 21 by 28 inches, driving wheels 57 inches in diameter, over tires with cast steel centers; weight on drivers in working order, 158,000 pounds; total weight of engine, 177,000 pounds; total weight of engine and tender in working order, 290,000 pounds. Capacity of tender cistern, 5,000 gallons.

Eleven ten wheel passenger engines. Cylinders, 20 inches in diameter by 26 inch stroke; drivers, 67 inches in diameter; weight on drivers, 123,000 pounds; total weight of engines, about 160,000 pounds; weight of engine and tender, 271,000 pounds. Capacity of tender cistern, 5,000 gallons.

Five six wheel switch engines are also being built. These have cylinders 20 by 26 inches, drivers 52 inches in diameter; weight on drivers in working order, 145,000 pounds, and total weight, 145,000 pounds; total weight of engine and tender in working order, 230,000 pounds. Tank capacity, 3,500 gallons.

There is an inclination to disparage the study of the English language by many college students, a piece of silliness that is liable to prejudice their business career.

Exceeding the Speed of the Locomotive.

BY ANGUS SINCLAIR.

For seventy years the locomotive engine has held the reputation of being the fastest manmade article to move through space, but it has lately descended to a second place. The locomotive had not been introduced on general railways two years when it attained a velocity of sixty miles an hour or, as the figures appealed to the popular mind, it ran at the rate of a mile a minute. That was remarkably fast compared to the speed of any other member of the transportation family, but subsequent improvements on the engine did not increase its speed making capacity. When people have talked about fast speed being maintained on certain railways, they always meant something under 60 miles an hour, and no regular trains, with one exception have ever averaged the velocity of 88 ft. per second, which the engineering world seemed to consider the limit of speed for a motor carrying its own source of power.

Now the humble looking automobile has suddenly jumped into prominence as a speed maker and carried away the laurels from the locomotive. In the course of a series of races held by automobilists on the beach of the East Coast of Florida in the end of January, W. K. Vanderbilt, Jr., broke the world's record for speed in running his German made 90 horse power Mercedes automobile one mile in 39 seconds, a velocity of 92.3 miles per hour; over 135 ft. per second. This was no isolated spurt where the partiality of timers would help out a few seconds, for the best developed electric apparatus was employed in recording the speed, and the single mile record was probably exceeded in a ten mile race which Mr. Vanderbilt accomplished in 6 minutes 50 seconds, an average of 41 seconds for each mile. During this race his friends say he made one mile in 35 seconds, equivalent to nearly 103 miles an hour, or close on 151 ft. per second. Think of passing three 50 ft. blocks every second!

The beach where the racing was done is wonderfully well adapted to racing purposes. The ocean, of course, covers it twice every twenty-four hours and leaves it about as hard as a macadamized road, with the added advantage that it is wet enough and cold enough to keep the pneumatic tires of fast running vehicles from becoming hot. One of the difficulties which people running fast racing motor cars have to contend with is the tendency of the tires to heat up and explode. I have frequently heard the question asked: Why does a pneumatic tire become hot under high speed while the steel tires of a locomotive hammer-

ing on steel rails remain cool. The explanation is that the compression shocks given to the air inside the tire are converted into heat just as a pump used to compress air becomes hot, or striking a piece of iron with a hammer produces heat. The heat inside the tire having no means of adjustment to the temperature of the surrounding atmosphere accumulates until it may reach the dangerous intensity that causes bursting of the tire. The wet beach keeps the tires so cool that the heat of concussion is dissipated. The tires of a locomotive, of course, are constantly passing through the air, which carries away the heat of contact as fast as it is generated.

There is an extraordinary peculiarity about the beach where this racing is done. It is composed of nearly pure silicon with a slight mixture of minute shells formed of lime. The mass becomes intensely hard as the water leaves it, but when it becomes dry the sand drifts like snow and is not unlike snow in appearance. There is a story

morning. The tide rises and falls only about two feet, so that the strip of nearly level beach is only about 150 ft. wide at low water. The period through which racing is practicable each day does not exceed four hours. This makes a good safe course when it is at its widest, but when it is narrowed up the driver is between a charybdis of dry sand on the one side, which has no more bearing strength than a bank of newly fallen snow and the tide washed Scylla, where, to quote ancient legions, "His vessel may be engulfed in the salt waters of the stern ocean." This is drawing an extreme picture for a detour from the straight and narrow way merely leads the motorist into a medium which will hold his vehicle fast. The tide washed beach is an ideal speedway in many respects.

I have picked out the Vanderbilt performance from several others that would have attracted wide world attention had they not been eclipsed by the achievements of the champion. This



VANDERBILT MAKING FIVE MILE WORLD'S RECORD.

The apparent deflection of the wheels and axles shown in the picture is an unexplained peculiarity of all photographs of automobiles taken when they are going at very high speeds.

told of two men named Wood, who had reached an age considerably over the four score years, and both were hale, hearty men. An investigator into longevity found that one of the Woods had led an unusually abstemious life, while the other kept himself constantly soaked in liquor. The investigator came to the conclusion that to preserve Wood it must be kept either very dry or very wet.

The Florida beach has a similar peculiarity. It is very soft when very wet, or when very dry. It solidifies immediately after the water goes off, but if an unlucky motorist ventures a few feet into the tide he is likely to remain there until he is pulled out, for the action of the driving wheels churns the sand like mortar. As there is practically no twilight in these parts, several of the automobilists were benighted on the beach and some of them having straggled into the water, by compulsion left their cars there until

is done because I wish to make comparisons between the work done by Mr. Vanderbilt's automobile and that of a first class modern locomotive.

In the February number of RAILWAY AND LOCOMOTIVE ENGINEERING there is an illustration and description of one of the latest passenger train locomotives belonging to the Pennsylvania Railroad which may be accepted as the highest development of that species of engine. I calculated that the engine develops some 2,000 horse power when running at 60 miles an hour, and is capable of hauling 400 tons at that speed. The weight is 183,130 lbs. for the engine and 90,000 pounds for the tender, a total of, say, 237,000 lbs., about 682 lbs. for every ton of train hauled. If that engine's speed was pushed to 90 miles an hour, I calculate that the load would have to be cut in two and that 1,360 pounds of engine would be needed for every ton moved, and one ton represents about half a passenger. The

Vanderbilt car weighs about 2,500 lbs. and carries two passengers, so it is nearly four times as efficient as a locomotive when considered merely as a prime motor.

The most extraordinary feature of the automobile considered from an engineering standpoint is the immense concentration of power in little weight and space.

There were great feats of skill displayed in some of the performances. For convenience in keeping the movements in short compass, the course was divided into sections of one, five and ten miles, requiring the racers to turn four times during the fifty mile race. In his second turn at the post where I was stationed, Mr. Vanderbilt went round in a style that was scarcely credible. Running about 40 miles an hour he turned on a radius of 150 ft. and came within 4 ft. 9 ins. of the post. One of the racers attempted to turn too sharp and his car was overturned, but the driver was thrown clear and escaped with a few bruises.

Speculations as to where a certain speed would carry a car or train in a given time are not very practical or edifying, but they are amusing. If Vanderbilt's velocity could be kept up all the way from New York to Chicago, the run between these cities could be made in 9 hours and 52 minutes. At the same speed the globe could be traveled round in 11 days and 6 hours.

Following up the idea of speed possibilities, when the highways are perfected, Mr. Vanderbilt or one of his racing successors might start from New York after an early breakfast for a brief tour. If he started at 8 A. M. he would reach Pittsburgh about 1 P. M. After an hour spent taking luncheon and a brief rest he would start about 2 P. M. and reach Chicago about 7 P. M., in time for dinner and a visit to the theater.

And so it may come to be that all the quarters of the globe will be brought into close contact by means of vehicles under the control of any owner. The speeds attained in these races are most eloquent in what they promise that the future may bring forth.

A Terrible Bear.

The following press dispatch was sent from Altoona, Pa., one day early in January: "While going up a steep grade near Dunlo early this morning, a Pennsylvania Railroad freight engineer saw a black object on the track ahead. Thinking it a man, he stopped, and as the light from the headlight flashed on the form it arose and walked toward the locomotive.

"Seeing it was a bear the engineer attempted to start the engine. Meantime, bruin leisurely inspected the lo-

comotive and tried to warm himself in the reflection of the headlight. The engineer tried in vain to start his engine. The steam pipes failed and the train lay frozen up for several hours until another engine could be secured. The bear, frightened by the whistle, ran off to the woods."

There is something mysterious to us about this story. Did the sight of that bear freeze the steam pipes? What would have happened to other trains if the bear had not taken to the woods?

Bung!

An ingenious method of handling a barrel of paint or oil so that the bung hole may be quickly placed where the contents will readily flow into a tank is to be found in the paint and oil store at the Reading shops of the Philadelphia & Reading Railroad.

The raising of the barrels is accomplished by the operation of an ordinary differential pulley block suspend-

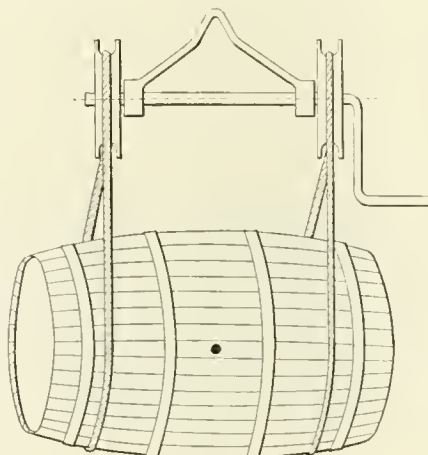

Railway & Locomotive Engineering
APPARATUS FOR TURNING A BARREL
OVER IN MID AIR.

ed from a run way overhead. The hook of the differential hoist holds a piece of apparatus such as is shown in our illustration. It is speaking generally, a small pair of grooved pulleys mounted on a shaft which has a crank handle at one end, the whole held up by a suitable hanger. A pair of rope slings are put over the grooved pulleys and around the barrel, and when hoisted to the proper height you just turn the handle and the barrel revolves in the air until the bung hole comes just where it is required.

Mr. R. Atkinson, the master mechanic of the shop, says that a sight at the handy little appliance generally provokes an approving smile from a visitor, and many wonder why they had not thought of so simple a rig. This reminds us of a story we once heard. A newspaper in the West which, in commenting on the intelligence of the horse, gave the example of one very sagacious equine

which had pulled the bung out of a barrel of water and had so got a drink. A facetious contemporary remarked that that was simply satisfactory, but that if the barrel had pulled the horse out of the bung hole and then had given him a drink, the thing would have been really wonderful. The P. & R. midair barrel revolver is not exactly wonderful, it is simply satisfactory, no one will deny that.

"We had a funny experience," said John Mackenzie at one time. "We had a fire claim and they said that the cause of the fire was a cracked stack which allowed the sparks to pass through and set fire to the right of way. When we came to look into the matter we found that quite a number of stacks were cracked. It appears that the men had been in the habit of putting bars of iron crosswise into the stack to intensify the draft. The bar would keep working down on the taper until it got jammed very tight and a sudden expansion would crack the cast-iron stack. The fire claims held good, but we stopped the practice of putting cross bars into the stacks."

A daily newspaper tells how a faithful employee of a large factory saved the whole establishment from fearful destruction. It gravely says: "Noticing that the water in the glass gauge was higher than it should be, and also that considerable steam was escaping, he hurriedly climbed up the ladder and shut off the steam, but the vapor blinded him and he missed a step, falling heavily to the floor. Unable to stand, he crawled to the injectors and shut them off, thus preventing an explosion.

There are so many inventors offering to save railroad companies 20 per cent. by the use of their inventions that a man claiming a saving of 10 per cent. for his device is laughed out of every railroad office he tries to work. As to fuel savers nothing will be considered that does not promise to save a quarter of the coal. Railroad officials are so much accustomed to listening to the talks of colossal liars that a modest man makes no impression.

The Frankfurter *Zeitung* in referring to the fact that the Khedive of Egypt, on his recent trip to Europe, rode from Calais to Paris on a locomotive, in preference to the special car provided for him, says that since Ferdinand of Bulgaria made such a trip from Salzburg to Munich, locomotive rides by royal personages have been officially forbidden on German railways, because of the danger of distracting the engineer's attention.

Air Brake Department.

CONDUCTED BY F. M. NELLIS.

Evils of a Dragging Hose.

Just now there is much discussion on water in the train pipe and the trouble it causes in cold weather by freezing. It is not believed there is now a very wide difference of opinion as to how the water gets into the train pipe. The greater part of it, as practically proved by many good air-brake men, comes from the air pump, and is due to a wrong arrangement of piping on the engine which permits the air to pass in a warm condition through the main reservoirs, into the train pipe, where

the neck of a horizontally held bottle and trying to blow the wad into the bottle. Of course the attempt was a failure. In view of this performance it was further argued that the snow in the coupling head met all the resistance that the paper wad did in the neck of the bottle, and a further resistance of having to climb against the force of gravity influence to get into the train pipe.

This is substantial argument as far as it goes, confirmed by practical experience, but it does not go far enough.

substantially co-operate in the movement to secure clear train pipes, by issuing and enforcing orders to train men, and others doing such work, to knock out the snow in the coupling heads, taking care not to injure the gaskets, before coupling up the hose.

The "Collision Energy Line."

A correspondent writes: "I note in last month's issue a description of the collision energy line, and how you draw it. I would like to know what right you

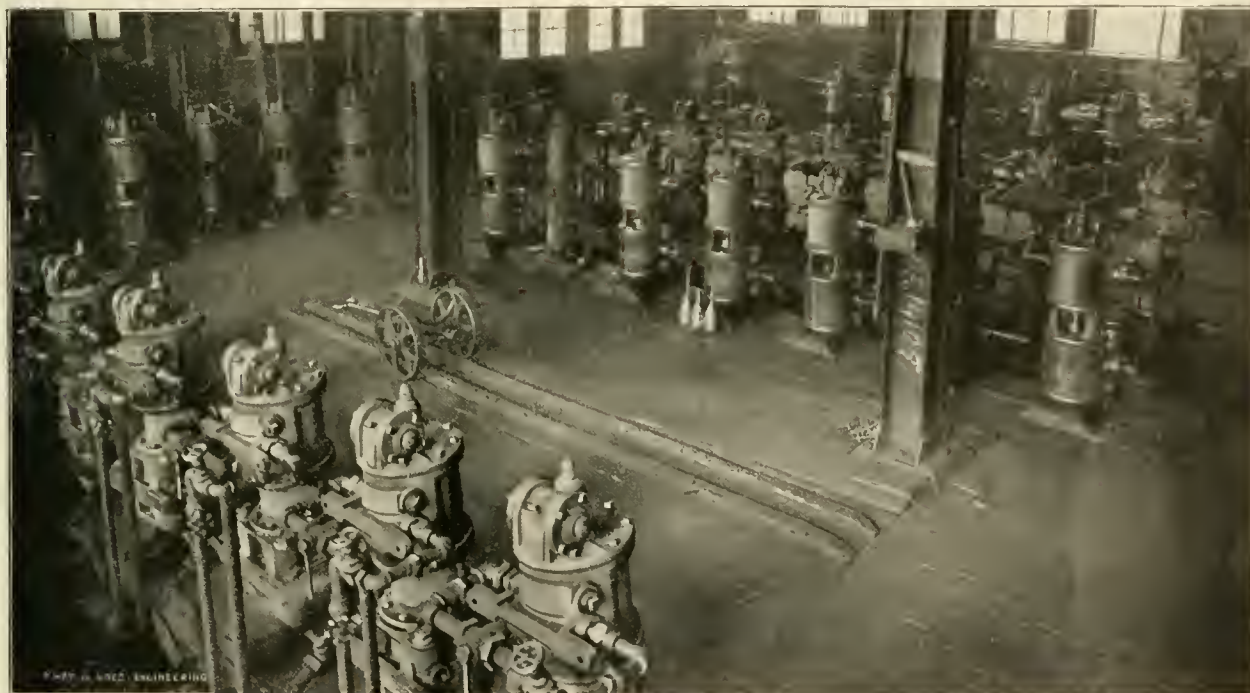

VIEW OF A CORNER IN THE PUMP ROOM OF THE WESTINGHOUSE AIR BRAKE COMPANY'S WORKS, WILMERTON, PA

it cools and deposits its moisture. A little snap of cold weather does the rest.

Another source of trouble is the snow which collects in the hose coupling head as the hose drags through deep snow, after a storm. This works into the train pipe, where it thaws if there is a warm spell, and when the cold snap comes, the train pipe freezes partly or wholly shut. A prominent railroad man once said he did not believe snow would work up through the hose into the coupling head, for to do so, the snow would have to perform some wonderful and impossible gymnastics. To clinch his argument, this official cited the case of a man placing a small wad of paper in the entrance of

Snow gets into the train pipe, nevertheless, but not by performing the extraordinary gymnastic feat referred to. The snow-clogged coupling heads are coupled together and the air pressure carries the snow into the train pipe where it melts and freezes. Reference to this feature seems unnecessary in view of its simplicity and familiar acquaintance by railroad men, but its frequent occurrence seems to demand greater prominence, else no remedy will be systematically applied, and frozen train pipes will be materially increased in number.

While motive-power officials are engaged in eliminating the causes of frozen train pipes on the head end of the train, transportation officials may

have to assume to draw this line and to make it represent collision energy."

In reply to this question we would say that there is no assumption whatever about this matter, the whole calculation being based on mathematical facts. The illustration we have used is a simple and graphic one of the comparative values of two stops made by the same train under the same conditions, and is used to give a more accurate measurement of the comparative values of the two stops than could be had if the ordinary method were employed, and the comparison were measured in feet. The ordinary comparison usually made merely shows that one stop is some few feet better than the other in respect to distance run, but it does not give

definitely the actual and essential difference. This difference, to be readily comprehended in its true light and importance, should be given in terms of destructive force, or ability to do damage if a collision occurred to the moving train the instant the other train had come to a standstill. The collision energy line does this, and shows the actual ability of the moving train, making the longer stop to do damage in a

conquered by the brakes, and that even though the train were to strike, it would be with such light force that no damage would be done. With this supposition the case would be dismissed with a very unjust and damaging misunderstanding. It will be seen, after all, that the only way to measure the advantage of one stop over another, is not in terms of the few feet betterment, which fails utterly of a satisfactory conclusion, but is

amount to very much, and that the difference could be easily overlooked, especially, if he takes refuge in the usual remark, "Oh, well, the speed is much reduced, and the train is running comparatively slow, and if it did strike anything, its force would be spent and the damage light." But this is a delusion and a serious mistake. By drawing a collision energy line, however, it will be seen that the ordinarily braked train, still running thirty-eight miles per hour at the point where the other stopped contains about 25,000,000 foot pounds of energy, capable of creating great destruction in case of a collision.

If this train were held like a rat by the tail up in the air 50 feet high, and were allowed to drop to the earth it would strike with a force of about 25,000,000 foot pounds. This would be about the same force of the blow it would strike in collision and as described by the collision energy line. Yet there are some heedless persons who would say that there is so little difference as indicated by the speed curve that the two stops in practice would have approximately the same value. But the "Collision Energy Line" tells a simple, truthful story of surprising value.

New York Air Brake Co.'s Compensating Valve for High Speed Brakes.

We illustrate herewith a "compensating valve" recently designed by the New York Air Brake Co. to be used in high speed brake service.

Fig. 1 is a view showing the pipe arrangement between the compensating valve and the triple valve and brake cylinder. As will be seen, the connection of the triple valve is made in the side cap of the triple valve, the other end of the pipe connecting to the lower part of the compensating valve. The brake cylinder pipe is connected to the upper part of the compensating valve. Fig. 2 is a top view of the piping arrangement.

Fig. 3 is the top view of the compensating valve, and shows the connections to the brake cylinder and triple valve.

Fig. 4 is a sectional view of the compensating valve. As will be seen, the valve may conveniently be divided into two separate portions, consisting of a lower portion and an upper portion. The upper portion consists of a piston, C, two packing rings, D, and a leather joint or seal on top of the piston. These parts operate in chamber B, which contains brake cylinder pressure. When in normal position, the packing rings, D, of the piston, C, cover small parts a and b.

The lower portion of the valve consists of chamber A, regulating spring, F, non-return check valve, G, and its spring, K. Z is the point at which pressure enters the compensatory valve to occupy cham-

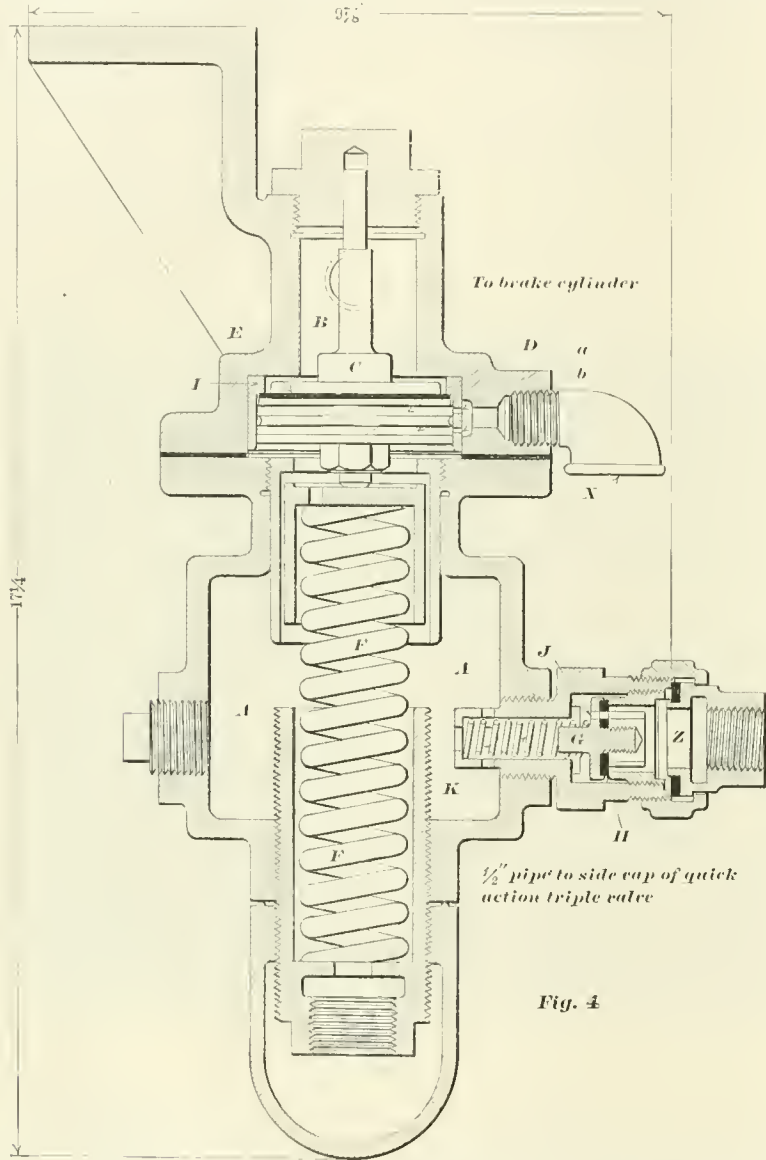

Fig. 4

SECTIONAL VIEW OF NEW YORK AIR BRAKE COMPANY'S COMPENSATING VALVE FOR HIGH SPEED BRAKES.

collision with its destructive energy at that instant.

The ordinary person, viewing the speed and stop curves of two trains, where stops have been made under the same conditions, is apt to say: "Its only a few feet—really no difference." But there is a difference, and a very great difference, too, although the casual observer is only too ready to let the matter pass as settled by believing that the train is nearly stopped, that all of the destructive force has, therefore, been

by considering the destructive energy contained in a moving train, which is capable of doing damage in case a collision occurred. For this reason we have adopted the "Collision Energy Line," believing that the name is appropriate and that the line shows the real difference in value at the two stops.

Take the illustration accompanying this article in which the collision energy line is plainly marked. At first glance one might believe that the few feet cut off by the high speed brake does not

ber A. The operation of the valve is as follows:

When an emergency application is made with the New York type of triple valve, train pipe air, as is well known,

pressure on piston C of about 78 pounds and a greater upward pressure, consisting of the combined pressure of the regulating spring and the air pressure in chamber A.

period of several seconds is required for the pressure in chamber A to reduce itself sufficiently low to permit the brake cylinder pressure on top of the piston to preponderate. Thus the greater pressure in chamber B will overcome the upward resisting pressure in chamber A, forcing piston C downward and uncovering ports a, through which the brake cylinder pressure will begin to reduce.

In this way the compensating valve is

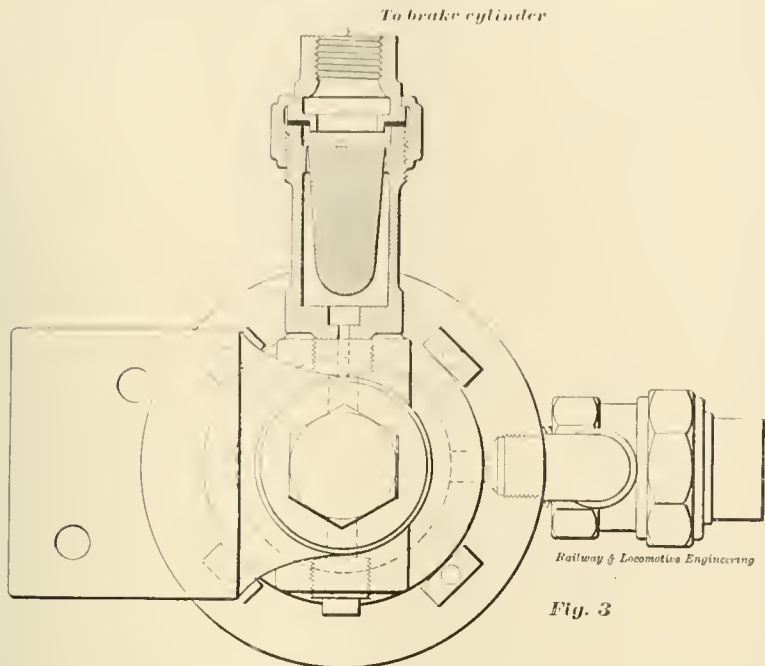

Fig. 3

is vented to the atmosphere. When the compensating valve is used, however, this air leaves the triple valve at the side cap connection of the triple, passes through the connecting pipe to Z, in the compensating valve, lifts the non return check valve G from its seat, passes into and occupies chamber A. The adjusting spring, F, having been previously set to give a resistance of 60 pounds, combined with the air pressure which has just entered chamber A, exerts an upward force on the piston C, greater than the downward pressure of the brake cylinder air on the top of the piston.

The emergency application, which gives only auxiliary reservoir pressure

Immediately upon the entrance of air to chamber A, this air leaks back

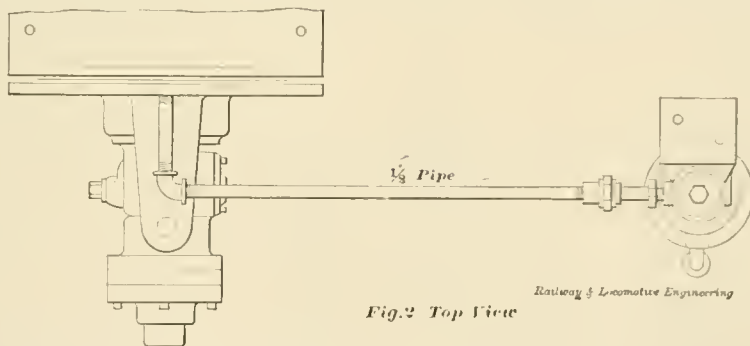

Fig. 2 Top View

made to hold the maximum brake cylinder pressure unreduced for a period of several seconds, then the brake cylinder pressure is gradually reduced until the pressure on top of the piston in chamber B is less than the upward pressure of the adjusting spring, 60 pounds, and the piston C returns to its normal position, which is its uppermost limit, and is sealed against the leather joint E.

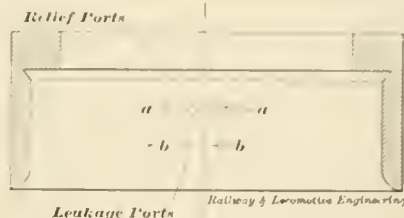

FIG. 5. PORTS IN BUSHING.

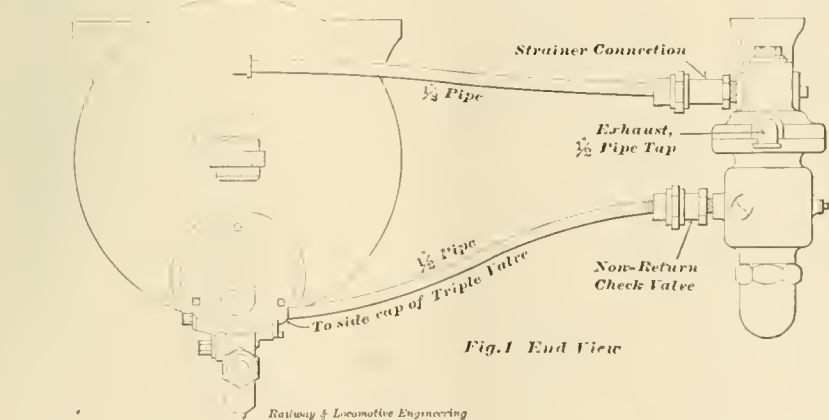

Fig. 1 End View

in the brake cylinder with the New York brake, amounts to about 78 pounds, assuming that 110 pounds train line pressure is carried and piston travel is closely adjusted. Thus there is a downward

triple valve, thence to the atmosphere, thus slowly reducing the pressure in chamber A.

The capacity of chamber A and small port J are so proportioned that about a

Fig. 5 shows a section of the bushing I in which the piston C and packing rings D operate. The upper row of six small ports are the relief or reducing ports a, one of which is shown in Fig. 4. The lower row, of two ports, b, (Fig. 4) are termed "leakage ports." However, inasmuch that said leakage would follow the same channel through which chamber A pressure escapes, ports b would seem superfluous for this purpose. They would seem to functionate to better advantage as additional relief ports in an abnormal service application.

In a service application the lower parts of the compensating valve do not functionate. However, if the brake cylinder pressure reaches a point higher than 60 pounds, the resistance of the adjusting spring piston C will make a downward movement and permit cylinder pressure to escape to the atmosphere through the series of ports, a, and possibly require the use of ports b also.

CORRESPONDENCE.

A Reminiscence of an Old Timer.

It might be of interest to your younger readers for an old timer to tell his reminiscence of the development of the retaining valve. The present standard retaining valve now used by the railroads throughout the country is the outcome of a series of practical tests and experiments made by the late Mr. H. C. Frazier, of the Westinghouse Air Brake Co., assisted by Mr. Levi Close, now dead and of the same company, on one of the heavy grades of the Rio Grande & Western nearly fifteen years ago. This grade has a fall of 200 feet to the mile, and a great deal of trouble was experienced on this grade with handling loaded trains. The trainmen would club the hand brakes to handle

Frazier then had some 25 and 30 lb. retaining valves made and tried them, but while they would hold the train from running away, they were such heavy valves that they would stop the train dead on a lighter grade. This put out of the question any heavier valves than the 20 lb. valve.

Mr. Frazier then took up the time element in the problem. Instead of having an unusually heavy weighted valve with a quick exhaust, he decided to use a small valve of 20 lbs. and restrict the discharge port through the valve. This he did for 20 lb. valves, and had a small escape port of about $\frac{3}{4}$ in. in diameter. The delay of the exhaust prevented the pressure from blowing out quickly and gave the train time to recharge. This is the Standard retaining valve of to-day, and is the outcome of Mr. Frazier's experiments on Soldier Summit, on the Rio Grande

the brake was released by the blow at the exhaust port.

The oil plug could be removed and a gauge attachment made, but plugs are so hard to get out and usually are in an inaccessible place, and could not be used when they were out because of being so near to the car sills that the gauge and connections could not be attached.

Surely some good test is needed for brake cylinders, for after this amount of important work has been done, it certainly should be tested. The practice of turning up the retaining valve when the brake is set, then releasing the brake, and afterwards turning down the retainer, noting the discharge, gives an approximate result, but it is not altogether satisfactory.

Chicago, Ill. H. B. HOWARTH.

An Air Brake Book That Is a Jewel.

While reading your very instructive paper this month, I wondered how many, if any, had as valuable an air brake book as I have.

The book I speak of contains one hundred and fifty-five pages, 11x8 $\frac{1}{4}$ ins., and is made of clippings from the RAILWAY AND LOCOMOTIVE ENGINEERING, treating on the subject of air brake appliances, questions and answers, and numerous other interesting air brake subjects.

The book has a cloth cover, and has on it a picture cut from the covering of a LOCOMOTIVE ENGINEERING dated "1896 Sinclair & Hill."

It took me a couple of years to get this book together, but I feel that I am fully rewarded by having so valuable a book. The RAILWAY AND LOCOMOTIVE ENGINEERING is without a doubt the best journal published for any one employed around a locomotive.

I will say further that I have begun a new air brake book, and in a couple years will add another jewel to my small library.

Round House A. B. Inspr.

Monett, Mo.

The coming convention of the Air Brake Association, to be held in Buffalo, beginning May 10, will be the eleventh convention of this body. The committee on arrangements has almost completed its work, and promises good hotel and entertainment facilities. The subject papers to be presented by committees and individuals are among the best yet offered to the association. Apart from these, topical subjects will doubtless be presented for discussion which will bring out the experience and progress made in air brake work during the past year. The opportunity to visit Niagara Falls on this occasion should not be ignored, and will doubtless be taken advantage of by those who have never witnessed the grandeur of this wonderful natural sight.

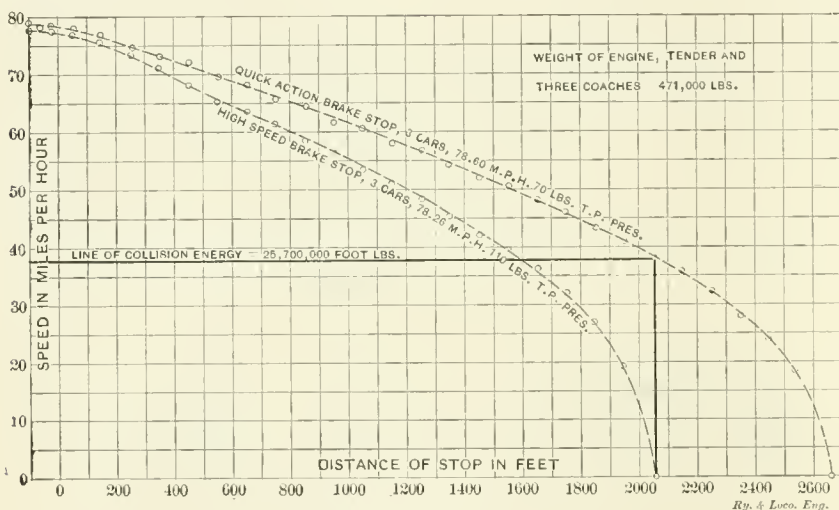

THE "COLLISION ENERGY" LINE.
(See pages 123 and 124.)

the train safely down the grade. These trains average something like 20 to 30 loads. The cars were 80,000 lbs. capacity, but were often overloaded with coal at the Provo mines.

It was found that the retaining valve at that time, which held but 15 lbs. pressure, and had an exhaust port of $\frac{1}{8}$ inch, would not hold the train down the Soldier Summit grade, ten miles long and almost straight track. A heavier valve was made in Pittsburgh and sent out to Mr. Frazier, by which 20 lbs. pressure could be held in the brake cylinder, but the train would get a start before it had fully recharged, on account of the quick blow down, in three or four seconds. Thus the train would get from under control. Mr. Frazier then blocked the retainers all down on their seats, and the train could be dropped with the air brakes and no help from the hand brakes. While this held the train safely on Soldier Summit, still it would not do for lighter grades, as it would stop the train. Mr.

& Western, on one of the heaviest grades in the West. C. E. BURNS.
El Paso, Tex.

Test for Brake Cylinder Packing.

I would like to ask your readers if any of them have a test for brake cylinders after they have been cleaned and lubricated. I want a test which will test the packing leather, the retainer pipe, and the retaining valve.

I have thought of the plan of disconnecting the retaining valve pipe at the union, next to the brake cylinder, making a quick and easy attachment for the gauge. Thus an accurate test of these parts could be made. It would also insure the union gasket being in good condition, because if a defective one was removed a good one would replace it when the coupling was again made.

Of course, a leak of the slide valve would let auxiliary reservoir pressure into the brake cylinder, but that would be so slight that it would not be very bad and could be easily detected when

QUESTIONS AND ANSWERS**ON AIR-BRAKE SUBJECTS**

(9) M. C. D., Pueblo, Colo., asks:

When two or more engines are coupled to a train in mountain service which man should handle the air going up, and which one going down the mountain? A.—In both cases the head man should handle the brakes. Possibly there is some extreme, or local condition, which prohibits this, and in which event, the second man handles the air. In ordinary service, however, the second man should cut himself out and allow the head man to do the work.

(10) J. R. O'D., Freeland, Pa., writes:

If you apply and release the brakes on a fifty car train, with main reservoir charged up, and the pump working, will the pressure fall into the train line faster than the feed groove in the triple valves can take it with the engineer's brake valve in full release? Will the train line raise higher than the auxiliary reservoir pressure. A.—With a good arrangement of train piping, so that the air has a free passage through, the train pipe pressure will be higher than that in the auxiliary reservoir; or, in other words, main reservoir pressure can be passed into the train pipe faster than the feed grooves of the triple valves can pass the pressure into the auxiliary reservoirs.

(11) B. M. R., Scranton, Pa., asks:

Is it possible for the retaining valve on a coal car to release itself by the continual jolting of the car on a down grade? A.—Brakes frequently leak off running down grades, when the retaining valves are turned up and supposed to be retaining pressure in the brake cylinder, but this is most generally due to defective leather packing in the brake cylinder and to leaky retaining valve pipes. The jarring action mentioned, while permitting a very small quantity of air to "spit out" at the retainer is comparatively infinitesimal, and will not seriously interfere with the pressure in the cylinder, and the consequent holding power of the brake. It should be remembered that the other sources of leakage mentioned are far more important and much more common than the escape of brake cylinder pressure, due to the jarring of the retaining valve. Again, it should be remembered that the pressure in the brake cylinder which is retained by the turned up retaining valve, is only held for a fraction of a minute, during the period of recharging, and not during the entire distance down the grade. Therefore, this escape of brake cylinder pressure, due to the jarring of the retaining valve on a rough riding car is rather far-fetched and overdrawn.

(12) C. B. E., Lynchburg, Va., writes:

On some of our cars here, when the cap is taken off the retaining valve, the little discharge port in the bottom is stopped up with rust and sand. Why wouldn't it be all right to make this port in cap and have it slope upward from the inside? Then no rust or sand would settle into the port and stop it up. A.—It is not believed that such a change would be a good one, inasmuch that rain and sleet would beat into the inside of the cap and freeze the valve to its seat. Snow and ice would also form on the top of the cap, and close up the port. Where the port now is, it would be difficult for these troubles to occur. Of course, the trouble would remain which now permits sediment to work into the port and stop it up, but that can be watched and controlled better than the other evil.

(13) J. E. S., Glens Ferry, Idaho, asks:

What is the advantage, if any, of carrying the New York Brake valve in running position while going up long grades, where no applications or recharging is required? and which is the proper position to carry this valve when using the air sand blowers continuously with a long train. A.—Excess pressure proves valuable on trains ascending a grade, in cases where the brake might creep on from any cause, or the train break in two, thus necessitating an excess or reserve pressure to release the braks. In these particular cases, and in others not mentioned, the value of carrying the brake valve handle in the running position is self-evident. Excess pressure is a good thing at any time, as a reserve, even though there may be no apparent immediate need for it. The continuous use of sand while aiding the engine in "keeping her feet," is a detriment, if used in large quantities, inasmuch that a great deal of the sand remaining on the rail after the engine has passed over it, will cause a hard pulling train. A small amount of sand, such as the engine actually needs and uses, will not remain on the rail to make a hard pulling train; but this amount will not work the sand blower hard enough to cause any trouble. However, if the sand blower is used excessively, and combined with train pipe leakage will aggregate an amount greater than the excess pressure valve can accommodate, and the air pump supply, then trouble may be experienced. The sand blower can be used just as well whether the main reservoir pressure is 20 lbs. higher or lower, providing train pipe leakage is not excessive and the air pump is maintained to a reasonable degree of efficiency. All things point to the advantage of carrying excess pressure at all times, and the advisability of keeping the apparatus in condition so it can be carried.

(14) M. J. McL., Mott Haven, N. Y., writes:

A brake stuck on the tender of a fast local passenger train. We could not release it by opening the release cock on the auxiliary reservoir, so we cut it out and let the pressure out at the brake cylinder by taking out the oil plug. After screwing in the oil plug, and cutting the triple in again, the brake would set but would not release. We cut the triple out again, but it would not release. Then we tried to pry the piston rod back into the brake cylinder, but could not do it or get the shoes away from the wheels, and had to take out the oil plug again. This delayed the train some time. We thought maybe the brake piston was froze in the cylinder, as we had taken water from a water crane at the end of the run, and the tank had been flooded, and the overflow leaked down over the auxiliary, triple valve, and brake cylinder, and froze. But the piston would work all right in setting the brake, and all right when the oil plug was taken out of the brake cylinder. But the brake wouldn't release with the engineer's brake valve nor with the release cock in the auxiliary. The brakes on the six cars in the train worked perfect, and so did the driver brake. We lost 20 minutes and was up for it. The next day the brakes worked all right on the whole train, including the tender brake. What was the matter with it? A.—The fact that you could set the brake proved that the triple was working and its inner parts were not frozen. Inasmuch that the brake was set two different times, it was thereby proved that the triple piston and slide valve would move to the release position as well as the application position. As the brake-cylinder piston moved out and in, proved those parts were all right and not frozen. But, as the oil plug had to be removed from the brake cylinder to allow the pressure to escape, and that pressure would not escape in the natural way, proves that the whole trouble lay in the release; that is, there was some obstruction between the brake cylinder and exhaust port of the triple valve. Undoubtedly the exhaust port of the triple was frozen up by the flooding of the tender in taking water. As the engine probably stood in the roundhouse over night, the ice in the exhaust port thawed out and allowed the triple to release all right next day. A plain triple valve which has the three position cut-out cock in the triple body, many of which are still in service, will not permit a brake to be bled off at the release cock in the auxiliary reservoir when the handle is in cut-out position, for then the brake cylinder and exhaust to the atmosphere are separated.

Who Really Invented the Link Motion?

BY W. L. CAMPBELL.

In *American Machinist*.

This may seem rather a late day to add to a discussion apparently closed half a century ago and to attempt to prove, despite all existing works on locomotive history, that Williams, and not Howe, invented the link motion. But facts supporting that view of the case have been brought to light, and it is but just and fair that they be here recorded.

William James, of New York, is said to have been the first to apply the link to a steam engine. This was between the years 1830 and 1840, while James was experimenting with steam road carriages. The road carriage venture proved a business failure, and the merits of the James link seemed not to have been recognized at the time. While some writers since then have given James due credit for his improved valve motion, they all concede to William Howe, a pattern maker in the Stephenson works, at Newcastle, England, the honor of inventing the ordinary shifting link, or what is known as the Stephenson link motion. It is this Stephenson link motion to which this article relates, and the facts presented come from no less an authority than Mr. Ralph L. Whyte, of Hamilton, Ont., who was not only chief draughtsman in the Stephenson works, when the link motion was invented, but was, in conjunction with Mr. William Hutchinson, who was manager of the works, the first to lay the link motion down full size on paper.

Mr. R. L. Whyte was born at Newcastle, England, in the year 1820. In 1835 he entered the drawing office of Robert Stephenson & Co., Newcastle.

Mr. Whyte remained with the Stephensons some eight years, attaining to the position of chief draughtsman, when he left England to take charge of an engineering works in France. A few years later, accompanied by his wife, who also is still living, he sailed for America, finally settling in Canada. For twenty years he was chief clerk in the Custom House at Hamilton. He is now in his eighty-fourth year, and although retired from business, is strong and active for his age.

Mr. Whyte possesses an exceptionally good memory. Although he has been out of active touch with locomotive building for more than fifty years, his recollections are clear and distinct, and he can throw direct light on many moot points connected with the early development of the locomotive. While at the head of the drawing office of Robert Stephenson & Co. Mr. Whyte had charge of much important work, not the least noteworthy of which was the designing of the "North Star," the first engine ordered by the Great Western Railroad.

The drawings for this engine were all made under Mr. Whyte's supervision.

Returning now to the link motion: Mr. Whyte, as chief draughtsman, was not only assigned to lay down this motion full size, but he was in direct touch with the circumstances preceding and attending its invention; and it might be said that it was the action of Mr. Whyte, in sending Williams with his sketch to Howe, that made it possible for the latter to claim the link motion as his own invention. Williams, a modest, unassuming lad, was the youngest draughtsman in the office, and to him Mr. Whyte insists that the credit of the invention rightfully belongs.

Before presenting Mr. Whyte's contentions and giving the true story of the invention of the link motion, in order to show how the matter has been distorted in history and how the present day version has come to be accepted, the



RALPH LITTLE WHYTE.

references to this subject in some of the more prominent works on locomotive development will be chiefly reviewed.

In 1846 the *Glasgow Practical Mechanic and Engineers' Magazine* published a series of articles describing the principal types of valve gear which had been in use up to that time. In the April number the locomotive link motion was taken up. This "elegant apparatus," the article states, was invented by Mr. Williams. In the continuation of the article in the May issue it is explained that a communication had been received from William Howe, of Newcastle, contradicting the statement that Mr. Williams was the inventor of the link motion, and claiming that Howe, himself, invented the link as originally applied by Mr. R. Stephenson to locomotive engines, but conceding to Williams the original idea of the link.

Howe forwarded to the magazine a sketch of Williams' scheme, stating that it had never been carried into effect. A front elevation and a side view of the Williams arrangement are shown in the article referred to, which, after dealing with the faults and impracticability of the device, reads: "Mr. Howe informs us, a fact which we need scarcely repeat, that the scheme was never actually put into practice, but leaves us to presume that it formed the ground work for the invention of the link motion." The matter is finally disposed of as follows: "As we have no wish to make our pages the vehicle of a useless controversy, we give insertion to the above drawings merely as a matter of common justice to Mr. Howe, the validity of whose claim we must leave our readers to decide."

The editor of this Glasgow monthly, though non-committal enough, would seem to accord to Williams at least some consideration, a tendency conspicuously lacking in subsequent writers on the subject, practically all of whom awarded to Howe undivided credit for the invention.

It is true that D. K. Clark in *Railway Machinery*, one of the first works on the locomotive, is generous enough to mention Williams' name in connection with the invention of the link motion. From Clark's introduction to the subject the following is taken: "Nothing but an impulse of genius could have given birth to this exquisite motion; and though in its first conception by Mr. Williams, at one time of Newcastle, it was rude and even impracticable, the idea was there, and it had only to be cleverly worked out by Mr. Howe to render it, in conjunction with the lap of the valve, the most felicitous acquisition to the locomotive since the introduction of the blast pipe and multitubular flue." Considering that the first inception of the link was by Williams and that had it not been for Williams and his idea it would have been impossible for Howe to work out his "invention" of the link motion, it might reasonably be wondered to whom Mr. Clark attributed the genius, "nothing but an impulse" of which "could have given birth to this exquisite motion," and if not altogether to Howe, why Howe should be given full credit for the invention. From Clark's "Railway Machinery," two sketches are produced herewith. Fig. 1 shows what is termed the Williams link. Fig. 2 is the familiar Howe, or Stephenson link. While ready enough to criticise the Williams arrangement, D. K. Clark tenders no information to strengthen Howe's claim and apparently takes for his authority for Williams' connection with the invention the letter written by Howe to the Glasgow magazine.

But in this respect "Railway Machinery" is hardly comparable with "Locomotive Engineering and Mechanism of

Railways," by Zerah Colburn, published 1864. In this illustrious work the subject is opened as follows:

"In 1842 or 1843 Mr. Williams, of Newcastle, is said to have designed the attempt at a link motion shown in Fig. 73 (Fig. 1), although this is copied from an *ex parte* drawing sent to the Glasgow *Practical Mechanic and Engineer's Magazine*, in 1846, by Mr. William Howe, of Newcastle, who claimed the form of link motion now in general use as his own invention. An apology is necessary for introducing such a mechanical blunder into these pages; but it has been said by those who ought to know better that Williams' contrivance 'contained the germ of the link motion, and needed only to be cleverly worked out to render it the most felicitous acquisition which the locomotive has received since the combination of the multitubular boiler and blast pipe!' It does not, on the contrary, require a second glance to perceive that the notable 'design' did not permit of making half a revolution of the driving wheels except by tearing this pseudo 'link motion' to pieces."

As it is not the purpose of this article to defend this "mechanical blunder," and as this "pseudo link motion" was never meant to be applied to a locomotive, and, moreover, as it was never intended by its originator to be seen outside of the Stephenson works—although this is anticipating—it is needless to deal at greater length with the criticism accorded the Williams design by Zerah Colburn.

It should be noted here also that the sketch referred to and showing the mechanism so fiercely criticised by Colburn was not made by Williams himself, but by Howe, and formed a portion of a letter intended by Howe to create the impression that Williams had invented nothing, or at least nothing of importance. There is nothing to show but that if Williams himself had made this sketch of his invention it might have been differently made.

While Williams fared badly enough at the hands of D. K. Clark and Zerah Colburn, he is ignored altogether by Angus Sinclair, Clement E. Stretton and other modern locomotive historians. These writers, however, appear to be possessed of more particulars connected with the invention of the link motion, and from C. E. Stretton's "Development of the Locomotive Engine" (1902), the following is quoted:

"Mr. William Howe, who was a fitter in the employ of R. Stephenson & Co., decided to place a curved link between the ends of the forward and backward eccentric rods to take the place of forks. He made a pencil sketch and wooden model, which were shown to Mr.

Robert Stephenson, who, seeing its merits, ordered it to be fitted to all engines constructed at his works." Further on, Mr. Stretton says: "Some correspondents to the newspapers have expressed the opinion that the 'introduction of the "link" was not an invention but an improvement.' By whichever name it be known, the fact remains that Mr. Howe's introduction of the link at once removed all the difficulties which had for years caused trouble with the 'fork motion,' and it did far more than this, by producing a complete and simple means of cutting off steam for expansive working." And

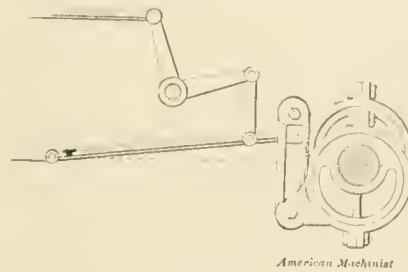

FIG. 1.

"The 'link motion' is frequently spoken of as Stephenson's, but this is an error, as Howe was the inventor, and Mr. R. Stephenson himself always spoke of it as Howe's."

How falsely Williams has been represented by the earlier writers and how unjust is the omission of his name in connection with the invention of the link motion by the later writers, can best be judged after reading the following account of the invention, related to the writer by Mr. Whyte, who probably alone survives those with whom he was associated at

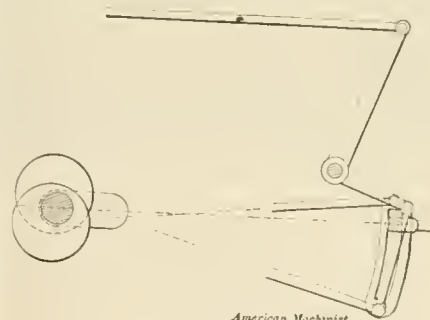

FIG. 2.

the Stephenson works, and than whom there is no one living competent to speak on this subject with greater authority. Mr. Whyte is a prominent citizen of Hamilton; he has always been known as a man of the strictest integrity and of the highest principles, and there is no questioning the veracity of any statement he would make. But he fully realizes the importance of this matter and desires it to be made known that he is prepared to take his affidavit as to the accuracy of what is said in this article concerning his connection with link motion.

In the year 1842, one morning about 6 o'clock, Mr. Williams, the youngest lad in the drawing office of Robert Stephenson & Co., of which Mr. R. L. Whyte was then chief, came to Mr. Whyte with a sketch of an improvement in the locomotive valve gearing. The chief draftsman was struck with admiration of the idea, realizing at a glance its possibilities. The sketch was the same as that shown in Fig. 1, consisting of a straight slotted link attached to the eccentric straps. The slide block in the slotted link hung from the end of a radius link from the valve spindle. The idea the sketch was made to illustrate was that by adjusting this slide block toward one or the other end of the link the valve could obtain the motion of either the forward or backing eccentric. Shifting the block toward the center of the link would reduce the travel of the valve and produce variable expansion. The motion would bring the engine under the direct control of the driver and allow him to make a quick reverse. Williams remarked that since making the sketch shown to Mr. Whyte (Fig. 1) he had further developed his idea, and that he had decided to place the link at the ends of the eccentric rods, curving it to the radius of the rods, and to attach the slide block directly to the end of the valve stem, effecting the reverse of the engine and variation in expansion by shifting the link vertically to any position required. Before doing anything further, Williams suggested that he make another sketch embodying these improvements. Mr. Whyte heartily accorded with this further development of Williams' idea; but as the introduction of the link itself was the most vital feature, he advised Williams, before proceeding with his suggested improvements, to have a skeleton model made from his first sketch, by Mr. Howe, who was then foreman of the pattern shop, and immediately to show this model to Mr. Wm. Hutchinson, a partner of Stephenson and general manager of the works. Williams then took the sketch to Mr. Howe, and it is but reasonable to assume that in explaining his ideas to the head pattern-maker the lad was just as frank as he had been when discussing the subject with the chief draftsman.

This sketch, it must be repeated, represented but one stage in the development of Williams' idea; the motion it outlined was not intended to be applied to a locomotive, and the drawing was not meant to go farther than the pattern shop in the Stephenson works, much less to be published and, as "Williams' link motion," made the target for shafts of misapplied criticism.

Two mornings after the incident mentioned, Mr. Hutchinson came to

Mr. Whyte and told him that Howe had made an important invention. This "invention" proved to be nothing more than Williams' link, but curved and placed at the ends of the eccentric rods (Fig. 2), embodying the identical improvements Williams had outlined two days before to Mr. Whyte, and which Mr. Whyte had advised the lad to defer making until he could get from the head patternmaker a skeleton model of the first sketch. At once detecting the deception, Mr. Whyte protested there and then that this "invention" was nothing but an impudent imposition, and he gave to Mr. Hutchinson the facts as stated above. Needless to say, the manager was surprised and shocked at this, and seemed scarcely able to believe what he had heard, as Howe had not mentioned Williams in any way and had given Mr. Hutchinson to understand that he (Howe) was alone responsible for the invention.

At that time Mr. Whyte was under engagement to go to France, but he was requested by Mr. Hutchinson to defer his departure for a few days and lay down the link motion full size. The managing partner and Mr. Whyte worked a fortnight at this, until they were fully satisfied with the importance of the invention—that besides bringing the locomotive perfectly under the driver's control, the motion afforded a variable cut off, allowing the steam to work expansively, thereby effecting a great saving in fuel. Mr. Whyte declares that there are absolutely no grounds for the contentions by some writers that all these capabilities of the link were not recognized when the motion was invented.

During the time that the link motion was being laid down, Mr. Howe was never in the drawing office, nor was his name even mentioned in connection with the invention, and Mr. Whyte left for France with the conviction that Williams would be well rewarded. As stated before, Mr. Whyte has been out of touch with locomotive building for over half a century, and it was not until a few years ago that he learned that Williams had been robbed of the credit of this invention.

Concerning the statement in C. E. Stretton's work that Howe made a pencil sketch and wooden model of the link, which were shown to Mr. Robert Stephenson, Mr. Whyte declares that as a matter of fact Mr. Stephenson was not in Newcastle at the time the link was invented, and that he did not see the sketch until the motion was drawn out full size and Mr. Whyte had started for France. Mr. Whyte never saw Mr. Hutchinson again, he having died, as had, also, Mr. Stephenson, before Mr. Whyte returned to Newcastle.

To any who still hold, notwithstand-

ing Mr. Whyte's revelations, that the improvements made by Howe on Williams' idea—improvements which were anticipated by Williams and which he intended to embody—constitute the invention of the link motion, and that Howe is entitled to full credit as such, this article will at least be of interest in the publicity it gives to certain relevant facts associated with this invention which the historians appear to have overlooked.

Whatever glory the link motion may have shed upon Howe, certainly his connection with its invention, in view of Mr. Whyte's disclosures, stands out in no enviable light, and perhaps the best that can be said for this patternmaker, unless he afterward made full restitution to Williams, is that such methods as he employed in "cleverly working out" this invention were not confined to William Howe, nor, it is to be regretted, to William Howe's day.

Publicity Better Than Secrecy.

Railroad officials have not been much given to taking the public into their confidence concerning the details of railroad management, but Mr. C. S. Mellen, president of the New York, New Haven & Hartford Railroad, is inaugurating a new policy in this respect. There is certainly a very violent prejudice against the N. Y., N. H. & H. in New England cities and the greater part of it is due to high handed treatment by the officials of the company, who acted on the principle that the public had no rights which were deserving of consideration. The change of sentiment led by the head of the company may be judged from the following extracts from an address delivered by Mr. Mellen before an organization of New England business men:

"Publicity, not secrecy, will win hereafter. Corporations must come out into the open and see and be seen. They must take the public into their confidence and ask them what they want and no more; and then he prepared to explain satisfactorily what advantage will accrue to the public if they are given their desires; for they are permitted to exist not that they may make money solely, but that they may effectively serve those from whom they derive their power. To my mind the day has gone by when a corporation can be handled successfully in defiance of the public will.

"Violent prejudice exists toward corporate activity and capital to-day—much of it is founded in reason, more in apprehension, and in a large measure it is due to the personal traits of arbitrary, unreasonable, incompetent and offensive men in positions of authority.

"The accomplishment of results by indirection, the endeavor to thwart the intention, if not the expressed letter of the law, a desire to withhold what is due, to

force by main strength or inactivity a result not justified, depending upon indifference of the claimant and indisposition to become involved in litigation, have created a sentiment harmful in the extreme and a disposition to consider anything fair that gives gain to the individual at the expense of the company."

Move to Modify the Interstate Commerce Law.

An act introduced into the United States Senate last month to amend the Interstate Commerce and Sherman Anti-trust laws created intense excitement among politicians, but one cannot understand what all the furor was about. The bill reads:

"That nothing in the act to regulate commerce, approved February 4, 1887, or in the act to protect foreign trade and commerce against unlawful restraints and monopolies, approved July 2, 1890, or in any act amendatory of either of said acts, shall hereafter apply to foreign commerce, or shall prohibit any act or any contract in restraint of trade or commerce among the several States, provided that such restraint be reasonable, or shall hereafter authorize imprisonment or forfeiture of property as punishment for any violation of said acts, except for perjury or contempt of court."

Some of the sensational papers immediately went to shouting that the measure was backed by the administration and that President Roosevelt had yielded to the trusts and to Wall Street. Probably this was not a good time to introduce such a measure, but something of the kind will be enacted some time. Certain politicians pretend intense hatred of any measure that would enable railroad companies to form some kind of agreement that would prevent ruinous competition in rates. If a privilege of that kind existed to-day there would be less consolidation of railroads by stock control.

This winter has sorely tried the patience of many passengers who had to wait long for belated trains, but abuse of the company or of the weather has not helped out any. A notice posted in some railroad stations seems to be very seasonable. It reads: "If trains are late go away back and sit down. Remember the old adage, 'Everything comes to him who waits.'" Don't make yourself conspicuous and others uncomfortable by 'throwing down' the road. The company is just as anxious to have the trains on time as you are."

When engineering papers first began to publish descriptions of new locomotives they always told the volume of steam used for each revolution of the driving wheels.

A New "Atlantic" for England.

The standard type for express locomotives on the British railways seems destined to be of the "Atlantic" pattern—and almost all of the leading systems possess engines of the class. One of the most modern examples is shown in the accompanying illustration, being for the Great Central Railway, and built by Messrs. Beyer, Peacock & Co., of Manchester. There are four engines built to the same general dimensions, but with this difference, that, whereas No. 192, shown, and another are of the "Atlantic" type, with four wheels coupled and a smaller pair of trailing wheels, the other two are of the "ten wheel" type, the trailing wheels being of the same

42 inches diameter spread over a wheel base of 78 inches; the drivers are 81 inches diameter, which is also the standard adopted by Mr. Robinson for coupled passenger engines; and the trailing wheels of the "Atlantic" are 51 inches in diameter. The cylinders, which are outside the frames and provided with tail rods, are 19½ ins. in diameter, with a stroke of 26 ins., and are inclined downward toward the second coupled axle at a slope of 1 in 48; the connecting rods measure 11 ft. 3 ins. between centers. The slide valves are of the Adams' balanced type, actuated by the ordinary curved link motion; as the links are in front of the leading coupled axle, the eccentric rods are curved in a portion of their length to

with a depth at front of 5 ft. 7¾ ins., and at back, of 4 ft. 7¾ ins. The grate area is 26 sq. ft., of which the fire box contributes 113.1 sq. ft. and the tubes 1,777.9 sq. ft. There are four 4 in. safety valves of a modified Ramsbottom pattern, which are adjusted to blow off at 180 lbs. per sq. in., though the boiler is designed to carry a working pressure of 200 lbs.

These engines are provided with steam sanding apparatus, delivering in front of the leading pair of coupled wheels; vacuum automatic brake fittings for working the train brakes; 40 mm. ejectors on the foot plate, with a valve for operating the steam brake which controls the coupled and trailing wheels of the engine, and the ten-



ATLANTIC TYPE PASSENGER ENGINE ON THE GREAT CENTRAL OF ENGLAND.

diameter as the drivers, forming a six coupled design. In all other respects the two series are identical, and it is, we understand, the designer's (Mr. Robinson) intention to test the two types on similar trains, and so obtain valuable relative data as to coal consumption, repairs and other items of cost as regards the "Atlantic" and "ten wheel" pattern respectively. They are designed to work the heavy passenger excursion services between London, Manchester and Grimsby.

From the reproduction it will be seen that these locomotives are designed on generous lines, and reach almost the extreme limits permissible by the loading gauge. The leading bogie is of the same pattern as was adopted in the six coupled engines last, having wheels

clear the axle in extreme fore and back gear; they measure 8 ft. 11½ ins. long from center to center; screw reversing gear is employed, the rod being on the right hand side of the engine. The boiler is of large size; the smoke box has a length inside 52¾ ins. and a breadth of 69½ ins. outside. The barrel is built up of three rings of 5⅝ in. steel plate, the smallest having an outside diameter of 57½ ins., and has a length of 15 ft.; it has its center line 8 ft. 6 ins. above the rail level, and contains 221 tubes, 2 ins. in diameter and 15 ft. 4¾ ins. long; they are 2 ins. higher at the fire box end. The Belpaire fire box has outside measurements, 8 ft. 6 ins. long by 4 ft. ½ in. wide; the internal fire box is 7 ft. ¼ in. long inside, by 3 ft. 4¼ ins wide,

der wheels; a Gresham & Craven re-starting injector, and a No. 10½ Davies & Metcalf exhaust steam injector on the left hand side.

The tender is provided with a water pick up apparatus of the latest type, and is of the standard pattern, having a capacity for 3,250 gallons of water and 5 tons of coal. It is carried on six wheels of 4 ft. 3 ins. diameter, distributed equally over a wheel base of 13 ft.

A Marvel.

At the classics he'd neer had a chance,
But in wisdom he led the whole dance.

Forsooth, he was able

To take a time table

And tell what it meant at a glance.

—Salt Lake Herald.

The Ogden to Lucin Cut-Off on the Southern Pacific.

The elimination of grades and the lessening of mileage, with all the economies which that means in railroad operation, has been the reason for the building of a short line across a piece of the Great American Desert and Great Salt Lake, on the line of the Southern Pacific. The cut off runs from Lucin, near the edge of the desert, to Strong's Knob, on the shore of the Salt Lake, and crosses the lake in a straight line to Promontory Point, from which it crosses the smaller or east arm of the lake and runs into Ogden. The whole line from Lucin to Ogden is practically a straight line, and the distance saved by the new location is about 50 miles.

The reduction in curves is considerable, the maximum curvature on the old line being 10° , while the new line maximum is 4° , and the construction engineers will tell you that the total angle degree saved is 12,690. That means that a train going round the old line had its direction of motion deflected so often that in comparison with the cut off line the straighter new route relieves the train from going round what amounts to more than 35 complete circles. That is what numerous reverse curves added together means, plus flange and tire wears, elevation of the outer rail, collar wear of journals and general discomfort of passengers when traveling over what many of them call a "seasick" line. The new road decreases the total gradient by 3,064 feet. The maximum grade on the original line being 89.6 ft. to the mile, while the cut off has only 21.12 ft. per mile, except for a short stretch, when the grade runs 79.2 ft. to the mile as the train rises from the level of the desert to reach the old line at Lucin. The trestle used in crossing Salt Lake is supported on 5 pile bents, and the trestle has a ballast top 14 ins. deep.

The work was dedicated on November 26, 1903, when the "last spike" was driven in presence of a distinguished company of railroad men. The original estimate of the cost of the cut off was \$4,000,000, but the engineering corps have encountered so many unforeseen difficulties and the handicaps imposed by nature have been so heavy that the original estimate is now far below actual figures.

At the present time, notwithstanding the recent opening ceremonies, the seemingly insatiable appetite of Salt Lake for tons upon tons of ballast has caused the track for a distance of 200 ft. to sink, to such an extent that a portion of the trestle is said to be useless. There is, however, no idea of giving up the work, and the Great Salt Lake, like the shifting and treacherous Chat Moss, on the old

Liverpool and Manchester Railway, will one day be conquered by the perseverance and skill of the indomitable railway engineer.

Have Your Pass Handy.

While Congressman Gardner, of New Jersey, was traveling from Trenton to Atlantic City the other day he could not find the pass which Congressmen are never supposed to accept. The conductor, who knew him very well, waited quietly by the seat until the Congressman had gone through his pockets and produced it.

"I had a lesson in that sort of thing once," the conductor said to a man on the train. "When George Roberts was President of the Pennsylvania Road, I found him in the smoker one morning on a run to New York, and just gave him a nod as I passed by.

"Here, my man," he said sharply, 'you have not looked at my pass.'

"But I know who you are well enough," I explained.

"That makes no difference. Duty is duty. If a passenger shows you neither a ticket nor a pass you should put him off the train. You may go.'

"But I haven't seen your pass yet," I said.

"The old man began to feel in his pockets, and I waited. 'Stop this way when you come again,' he said. In a few minutes I came back, and he handed me a five-dollar bill without a word. I took out a single fare and gave him the change. He had left his pass in the Broad street station."

Paying for the Kansas Floods.

The Kansas floods, which destroyed railway rolling stock and upset bridges and carried away what was not exactly permanent in the permanent way, was recently made the subject for arbitration before a committee of the American Railway Association.

The companies which had suffered loss by reason of their cars having been damaged or destroyed by flood claimed recompense from the companies whose tracks had been flooded, on the ground that the rule requiring the prompt return of cars to owners in as good condition as that in which they had been received was in force and applied to the case in question.

The flooded out companies protested that the whole matter formed an exceptional case, and that the destruction of cars by flood was really the act of Providence. This contention, however, was not sustained, and the companies upon whose tracks the cars stood at the time when the rising waters engulfed them were held to be debtors to the owning companies and were ordered to pay up in accordance with the pro-

visions of the M. C. B. rules as adopted by the American Railway Association.

This decision will have the effect of giving another incentive to railways to get foreign cars home in the shortest possible time. The per diem principle can be seen shining through every chink and cranny of the ruling of the committee.

The only legitimate use of a car on a foreign road appears to be when it is moving along with a revenue load or going back to owners on what signal engineers would call a "high speed route." If you side track your neighbors' cars or permit them to be caught in a flood or a fire or a cyclone you must pay for your fun; therefore, if you don't like the thought of such payments, get them home.

This reminds us of a story of a hard skulled ducky who, while walking beside a building which was being erected, was startled by the fall of some bricks from about the level of the fourth story. The first brick which fell on his head broke in two, a second and third followed and were also disintegrated in the same way. The negro thereupon called out to the bricklayer above in a sort of a sorry-for-you-but-I-can't-help-it voice, "Look here, mister, if you don't want your bricks broken, keep them off my head."

First Locomotive Brought Into Iowa.

It is just about fifty years ago that the first tie of what was then the Mississippi & Missouri Railroad was laid near the corner of Second and Main streets, in the town of Davenport, Ia. That line is now part of the Rock Island system. Two years after that interesting ceremony, being about July, 1855, the first locomotive ever brought into Iowa came across the river on a flat-boat. The engine was called the "Antoine Le Claire," in honor of the gentleman who had laid the first tie.

The Hon. A. C. Fulton, who was one at least, if not the prime mover in the Mississippi & Missouri Railroad scheme, speaking to a reporter not long ago on this subject, said he had often seen it stated in the newspapers that the first engine brought into the State of Iowa had been taken over on the ice. Mr. Fulton, who remembers the circumstances perfectly, says that the first engine floated into Iowa, while the one which made its way over the ice was the "John A. Dix," but the "skater" was not the first.

There is one ideal fact that we should never forget, and that is: we are here to make some one happy. We should compel each day to furnish an opportunity.

Of Personal Interest.

Mr. C. W. Jones has been appointed road foreman of engines on the San Joaquin division of the Southern Pacific Company.

Mr. W. S. Galloway has been appointed master mechanic at Grafton, on the Baltimore & Ohio Railroad, vice Mr. A. P. Prendergast, resigned.

Mr. S. Moffit has been appointed assistant road foreman of engines on the Saginaw and Grand Rapids districts of the Pere Marquette system.

Mr. A. Gordon Jones has been appointed superintendent of the Norfolk division of the Southern Railway, vice Mr. H. A. Williams, transferred.

Mr. D. D. Carothers has been appointed chief engineer on the Baltimore & Ohio, in charge of construction, reporting to the third vice-president.

Mr. W. J. Jenks has been appointed superintendent of the Fourth Division of the Seaboard Air Line Railway to succeed Mr. W. R. Hudson, transferred.

Mr. George Auchter has been appointed as an inspector by the Interstate Commerce Commission. Mr. Auchter was lately chief of Division 53, B. of L. E.

Mr. W. J. Wilcox, master mechanic of the Mexican Central, at Monteray, has been transferred to Chihuahua, on the same road, and in the same capacity.

Mr. W. R. Hudson, superintendent of the Seaboard Air Line Railway, has been transferred to the second division, vice Mr. A. W. Towsley, assigned to other duties.

Mr. A. W. Towsley has been appointed assistant to the president of the Seaboard Air Line Railway, with office at Portsmouth, Va., vice Col. T. M. R. Talcott, resigned.

Mr. John F. McNamee has been elected editor and manager of the Brotherhood of Locomotive Fireman's Magazine. The magazine office is at Indianapolis, Ind.

Mr. G. H. Wilson has been appointed superintendent of the Hartford Division of the New York, New Haven & Hartford Railroad, vice Mr. T. H. Fennell, transferred.

Mr. T. H. Fennell has been appointed superintendent of the New York Division of the New York, New Haven and Hartford Railroad, vice Mr. G. H. Wilson, acting superintendent.

Mr. H. H. Brown has been appointed superintendent of the Southern Division

of the Kansas City, Memphis & Birmingham Railroad, with office at Memphis, Tenn., vice J. A. Quinn, transferred.

Mr. F. G. Hatswell has been appointed to the position of assistant road foreman of engines on the Pere Marquette system. Mr. Hatswell will be on the Saginaw and Grand Rapids district.

Mr. J. A. Quinn has been appointed superintendent of the Western Division of the St. Louis & San Francisco Railroad, with headquarters at Neodesha, Kan., vice H. H. Brown, transferred.

Mr. J. P. Miller has been appointed road foreman of engines for the territory between Elkhart and Toledo on the Lake Shore & Michigan Southern Railroad, with headquarters at Toledo, Ohio.

Mr. Jno. D. Matheson, formerly traveling engineer on the Oregon Railroad & Navigation lines, has been promoted to the position of general foreman of the La Grande, O., shops of the same company.

Mr. J. J. Cavanaugh, who was lately appointed roundhouse foreman at Mexico City on the Mexican Central, has lately been transferred to Juarez, Mexico, as mechanical foreman by the same company.

Mr. N. E. Smith, superintendent of telegraph on the New York, New Haven & Hartford Railroad, has been given charge of the consolidated telephone and telegraph departments. Office at New Haven, Conn.

Mr. James Connors has been appointed district master mechanic of the Southern District of the Chicago, Milwaukee & St. Paul Railway, with office at Dubuque, Iowa, vice Mr. Geo. H. Brown assigned to other duties.

Mr. William Dellert has been appointed road foreman of engines in passenger service on the New York division of the New York, New Haven & Hartford Railroad with headquarters at 46th street, New York City.

Mr. J. J. Dowling, formerly road foreman of engines on the Montana division of the Great Northern Railway, has been appointed master mechanic on the same road with headquarters at Everett, Wash.

Mr. W. H. H. Webster, a well known railroad man, popular with the locomotive engineers of this country, has been appointed by President Roosevelt to the position of United States Consul at Niagara Falls, Ontario, Canada.

Mr. C. D. Shaft has been appointed traveling engineer on the Eastern Division of the Rome, Watertown & Ogdensburg Railroad, with headquarters at Watertown, N. Y. This road is part of the New York Central system.

Mr. David Patterson has been appointed general foreman, locomotive department, of the C. & C. B. Iowa division of the Chicago, Milwaukee & St. Paul Railway, with office at Marion, Iowa, vice Mr. James Connors transferred.

Mr. H. A. Williams, formerly superintendent of the Norfolk division of the Southern Railway, has been transferred to the superintendency of the Savannah division with office at Columbia, S. C., vice, Mr. P. I. Welles, resigned.

Mr. Walter S. Brazier, formerly an engineer on the Fitchburg division of the Boston & Maine Railroad, has been appointed traveling engineer of the Fitchburg division of the same road with headquarters at Mechanicsville, N. Y.

Mr. John Lonergan has been promoted to the position of foreman of the locomotive shop of the Delaware & Hudson Railroad, at Green Island, N. Y. Mr. Lonergan has been in the employ of the company for many years.

Mr. A. J. Cunningham, formerly general foreman on the Chicago, Rock Island & Pacific Railway at Trenton, Mo., has been transferred to Horton, Kan., and has been promoted to the position of superintendent of shops at that point.

Mr. Joseph McCabe has been appointed road foreman of engines on the New York division of the New York, New Haven & Hartford with headquarters at Harlem River, N. Y. Mr. McCabe is chief engineer of Division 589, B. of L. E.

Mr. S. Phipps, locomotive foreman at Medicine Hat, West Assn., on the Canadian Pacific, has been appointed to the position of master mechanic of the western division of the same road at Calgary, Alta., vice Mr. S. J. Hungerford transferred.

Mr. F. P. Brady, formerly assistant general superintendent of the Central Division, has been appointed general superintendent of the Lake Superior Division of the Canadian Pacific Railway, with headquarters at North Bay, Ont., vice Mr. G. J. Bury, transferred.

Mr. J. J. Reid has been appointed general master mechanic, with jurisdiction over all divisions on the Louisville & Nashville Railroad. He will have supervision over all shops, and will perform

such duties as may be assigned to him by the superintendent of machinery.

Mr. P. J. Cooligan has been appointed general foreman of the Illinois Central shops, Clinton, Ill., vice Mr. E. G. Hendrick, transferred. Mr. Cooligan has been round house foreman on the Rock Island for the past three years at Natick and 47th street, Chicago.

Mr. H. H. Vaughan, formerly assistant superintendent of motive power on the Lake Shore & Michigan Southern Railway, has been appointed superintendent of motive power for lines east of Port Arthur, Canadian Pacific Railway, with office at Montreal, vice Mr. H. E. Williams, resigned.

Mr. William Cross, heretofore engineer of tests on the Canadian Pacific Railway, at Montreal, has been appointed assistant to the second vice-president of that road with office at Winnipeg, Man. He will have general supervision of all mechanical matters on the lines west of Port Arthur, Ont.

Mr. W. E. Fowler has been appointed master car builder, Eastern lines, Canadian Pacific Railway, with office at Montreal. The car department was formerly in charge of the superintendent of rolling stock, but is now made a separate department. Mr. Fowler will report to the vice-president.

Mr. S. J. Hungerford, formerly acting master mechanic on the western division, Canadian Pacific Railway, has been transferred to the central division of the same road in the position of superintendent of the locomotive works, which is the name the company's enlarged shops are now called, at Winnipeg, Man.

Mr. E. A. James, heretofore general superintendent of the Canadian Northern Railway, has been appointed general manager of that road and subsidiary lines with office at Winnipeg, Man. Mr. James commenced his duties with the Canadian Northern on October 25, 1902, and since then has made a showing which must be gratifying to the company as well as to himself.

Mr. J. J. Sullivan, master mechanic of the New Decatur shops of the Louisville & Nashville, has been promoted to the position of general master mechanic of the New Decatur shops and of the following divisions of the Louisville & Nashville system: Nashville and Decatur, Nashville, Florence and Sheffield. Mr. Sullivan takes the place of Mr. A. Beekart, resigned.

Mr. C. F. Giles has been appointed assistant superintendent of machinery on the Louisville & Nashville Railroad, vice Mr. Harry Swoyer, resigned. Mr. Giles will have full authority to act for the

superintendent of machinery in all matters pertaining to locomotive service and distribution of power. He will also perform such other duties as may be assigned to him by the superintendent of machinery.

Geo. W. Wilden.

Mr. George W. Wilden has resigned as mechanical engineer of the Central Railroad of New Jersey to accept the position of assistant mechanical superintendent of the Erie Railroad with headquarters at Meadville, Pa. Mr. Wilden, who is a technical graduate, entered railway service in July, 1892. He served in the following positions on several of our leading roads. On the A. T. & S. F. he held the position of draughtsman and machinist at Topeka, Kan., and machinist and fireman at Raton, New Mexico. He was locomotive engineer, and assistant in the chief engineer's of-



MR. GEO. W. WILDEN.

office, on the Mexican Central. Superintendent of machine shop of the Aer Motor Company, Chicago. Locomotive engineer on the Chicago & Alton. Machinist, locomotive and car inspector and mechanical engineer on the Plant System, and for the past three years he has been mechanical engineer on the Central Railroad of New Jersey. He is first vice president of the traveling engineers' association, a member of the A. S. M. E., of the M. M. and M. C. B. Associations, of the Air Brake Men's Association, of the Franklin Institute, and of the New York Railroad Club. The varied experience which Mr. Wilden gained both in the technical and practical work which he has done is a guarantee of success in the larger field which he now enters. RAILWAY AND LOCOMOTIVE ENGINEERING congratulates Mr. Wilden on his promotion and wishes him every success.

Mr. T. McHattie, master mechanic on the Grand Trunk Railway at Montreal, was recently elected president of the Canadian Railway Club. He was vice-president of that organization for the past two years. He has always been identified with any movement which had for its object the improvement of motive power men and efficient methods of handling and caring for locomotives and train service generally. He was born at Dufftown, Banffshire, Scotland, August 8, 1854.

Mr. M. P. Cheney, who for the past year has been traveling engineer for the American Locomotive Company in connection with their Brooks Works, has been appointed engine foreman on the Chicago, Rock Island & Pacific Railway, with headquarters at Trenton, Mo. Mr. Cheney is an air brake man of considerable ability, and up to the time he entered the services of the Brooks Locomotive Works, had been road foreman of engines on the Grand Rapids District of the Pere Marquette Railway in Michigan.

Mr. H. Swoyer, assistant superintendent of machinery of the Louisville & Nashville at Louisville, Ky., has resigned his railroad position to become assistant general manager of the Rogers Locomotive Works of Paterson, N. J. Mr. Swoyer began railroad work on the Pennsylvania. He held the positions of general foreman and master mechanic on the Atlantic Coast Line Railway, and was general master mechanic on the Louisville & Nashville, and later was assistant superintendent of machinery on the same road before going to the Rogers Locomotive Works.

E. W. McKenna has been appointed assistant to President A. J. Earling, of the Chicago, Milwaukee & St. Paul Railroad. Mr. McKenna was formerly for many years associated with Mr. D. W. Caldwell, on the P., C., C. & St. L., and was later general superintendent of the Great Northern Railroad's Eastern division. He was born in 1848, and during the civil war was connected with the United States military telegraph service. He is the inventor of the process for renewing steel rails, and was the organizer of the McKenna Steel Working Company.

Mr. Joseph Billingham, the well known master mechanic, who lately resigned from the Baltimore & Ohio, to enter the employ of the Galena Oil Company, has gone to represent the company in Great Britain, with headquarters in London. Mr. Billingham will be at home in his new sphere, for he learned the machinist business in the shops of the Great Northern Railway, and his father was an engine driver on that road for about half a century.

His mother is still alive, and Mr. Billingham feels as if he was returning home from a far country.

Railroad engineers visiting Washington, D. C., will receive a kindly welcome by calling on Mr. Frank P. Sargent, Commissioner General of Emigration. Mr. Sargent was for many years Grand Master of the Firemen's Brotherhood, where his popularity was world-wide. He appears to be as popular among the high officials of the nation's capital. During a recent visit which the writer made to Washington Mr. Sargent steered him to an interview with President Roosevelt, who displayed his usual cordiality to one who had handled the locomotive throttle. The fact of being an engineer insures a man a warm handshake from the President.

Mr. George J. Bury has recently been transferred to Winnipeg as general superintendent of the central division of the Canadian Pacific Railway. Mr. Bury has for several years been superintendent of the Lake Superior division, and, as it was almost entirely on his suggestion that the company originally decided to place the headquarters of that division at North Bay and spend over a quarter of a million dollars there on improvements, the citizens of that thriving town naturally feel that they are under more than ordinary obligations to him. The regret at losing Mr. Bury is general. A banquet was given to him before his departure for the West.

Mr. D. P. Kellogg, who has lately been appointed master mechanic of the San Joaquin division of the Southern Pacific, with headquarters at Bakersfield, Cal., is well known to the readers of RAILWAY AND LOCOMOTIVE ENGINEERING, having been for years a valued contributor. He commenced railroading as an apprentice on the Missouri Pacific in Kansas, in 1886. Worked in contract shops in Utah as machinist and setting up machinery. He went to the Chicago, St. Paul, Minneapolis & Omaha as round house foreman in 1890, and held that position until 1894, when he went to the Duluth & Iron Range, as back shop and machine foreman until November, 1898. In that year he went to Southern Pacific as air brake inspector of the Western division car department. One month later he was made general foreman, mechanical department, at Oakland, which he left for the higher position.

Mr. P. H. Wilhelm, formerly representing the New York Car Coupler

Co., the Washburn Car Coupler Co., the Buckeye Malleable Iron & Coupler Co., the Railroad Supply Co., of Chicago, with headquarters at Atlanta, Ga., has accepted a position as railroad representative of the American Steam Gauge & Valve Mfg Co., Boston, Mass., with branch offices at New York, Chicago, Philadelphia and Atlanta, Ga. Mr. Wilhelm has spent the greater portion of his life in active railroad service. In 1893, he was, on the recommendation of the majority of the railroads concerned, appointed division superintendent of transportation at the World's Fair, in Chicago. After the close of that exposition, he took up the business of railroad supplies which he has followed up to the present time. The American Steam Gauge & Valve Mfg. Co., being the oldest house of the kind in this country, Mr. Wilhelm will certainly

ship for about one year. He then went to Chicago and entered the real estate business. This led him into an investigation of Government land frauds in Iowa, in exposing which he was brought to the attention of the public as a forceful writer, which led to his becoming city editor of the Chicago Times.

When that paper was sold to McCormick he went to New York City and engaged with Thomas Prosser & Sons, and was the first to introduce Krupp tires in America. Severing his connection with this firm he went to the old firm of Nathan & Dryfus, which, in 1884, was succeeded by the Nathan Manufacturing Company, in which firm, from that date to the time of his death, he was vice-president.

Mr. Toothe was one of the most widely known railroad supply men in the country, a genial, kind and courteous gentleman. He was a member of the Literary Club, the Colonial Club, the Lawyers' Club, the Metropolitan Museum of Art, the New York Botanical Society, the New York Zoological Society, the New York Railroad Club, the Southwestern Railroad Club, as well as the Juniata Club, of Altoona, during its existence.

He is survived by his widow, three daughters, Mrs. Jennie W. Hughs, Mrs. Walter A. Coe and Mrs. J. D. McGuire, and a son, Edward S. Toothe, western manager of the Nathan Manufacturing Company. The home of the late Mr. Toothe was in Madison, N. J., but he spent the winter months at the Fifth Avenue Hotel, New York City.

Mr. A. H. Gairns has been appointed master mechanic of the Missouri Division of the Chicago, Rock Island & Pacific Railway, with office at Trenton, Mo., vice Mr. M. S. Monroe, resigned. Mr. Gairns was formerly master mechanic at Estherville, Ia., on the same road.

Mr. J. A. Sheppard has been appointed roundhouse foreman at Cedar Rapids, on the Chicago, Rock Island & Pacific Railway, vice Mr. C. E. Langton, resigned.

Mr. J. H. Stubbs has been appointed master mechanic of the Nebraska Division of the Chicago, Rock Island & Pacific Railway, vice Mr. D. A. Hathaway, assigned to other duties.

Mr. Thomas Hopkirk, chief clerk of the mechanical department of the Canadian Pacific Railway, at Montreal, has accepted the position of chief clerk to Mr. W. S. Morris, mechanical superintendent of the Erie Railroad, at Meadville, Pa.



THE LATE WILLIAM TOOTHE.

be able to keep up his reputation in representing this well known concern.

Obituary.

WILLIAM TOOTHE.

Mr. William Toothe, vice-president of the Nathan Manufacturing Company, died January 24, at the Fifth Avenue Hotel, New York city, in his 73d year. Mr. Toothe was born in Birmingham, Warwickshire, England, in 1831. After learning the metal and electroplate trade with his father, he left after a year or two and entered the office of James Denham Barney, an American merchant. On becoming of age he came to Brooklyn and took up a clerk-

Handy Shop Appliances.

I send you herewith a sketch of a slotter bar which has proved to be the best of any we have ever used. We have made a number of different kinds of bars, but they have all been sidetracked for this one. You will notice that the position of the tool may be changed without stopping the machine, and if you wish to change tools, it is not necessary, as in the case of a solid tool, to stop the machine and loosen up four large clamp nuts. The small tools in this bar do not

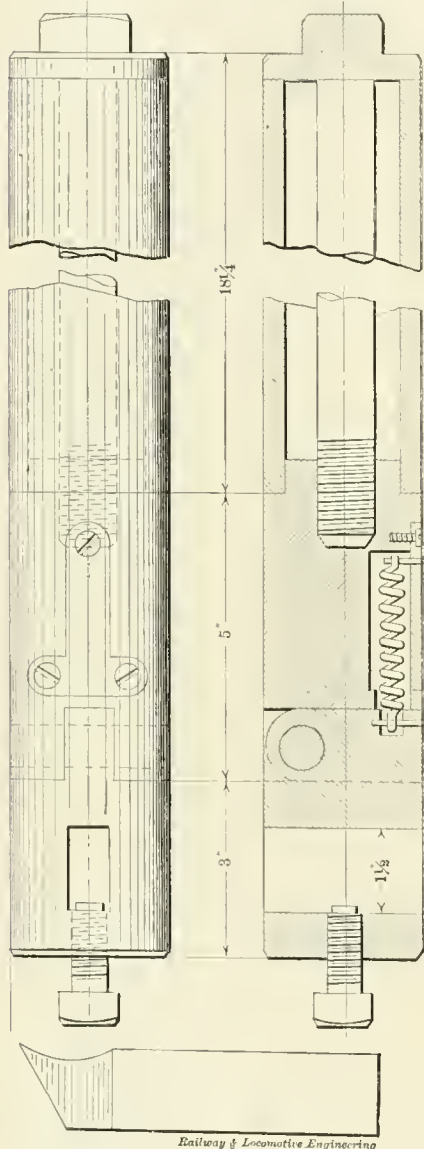

SLOTTER BAR, SANTA FE SHOPS.

require dressing owing to the fact that they are small enough to be easily ground to shape. This of itself is quite a saving both at the tool fire and at the steel rack. Instead of having three or four hundred pounds of steel in the form of solid tools piled up by the slotter, which pile represents expensive blacksmith work, we use an easily made, neat little tool which gives every satisfaction. I made this bar several years ago. It is not patented, and those who wish to prove its merits may do so by giving it a trial.

I also send you a sketch of the mandrel for turning up locomotive eccentrics used in our shop. There are quite a number of styles in use throughout the country, but for simplicity and accuracy I believe this one hard to beat. You will notice that each block is large enough to give three different throws; the extended center in head stock of lathe is a neat fit in the mandrel block, which prevents any variations in throw. The mandrel block is held firmly against spider of lathe by suitable bolt which acts as a driver and at the same time makes the mandrel rigid. If the readers of RAILWAY AND LOCOMOTIVE ENGINEERING have anything better along this line, I should be glad to see it published in your paper.

J. B. PHILLIPS,
Machine Shop Foreman A., T. & S. F.
San Bernardino, Cal.

The Pennsy's Exhibit at St. Louis.

The Pennsylvania Railroad are going to have an extensive exhibit at the St.

Long Island Railroad. The portals at both ends of the tunnel and sufficient area to give a good idea of the terminal facilities will be shown. A full sized section of the tunnel about twenty feet long will be exhibited to make clear the construction and the method to be used in supporting the tube upon its foundations.

Another model which will appeal to New York visitors especially is that of the Manhattan Island terminal of the Pennsylvania Railroad to be at Thirty-first to Thirty-third streets and Seventh to Eighth avenues. This model will be about 31 ft. 5 ins. long, 16 ft. wide, and 6 ft. deep.

A model of the West Philadelphia improvement from Thirty-second and Market streets to Fifty-second street, 6 by 18 ft., will be on exhibition.

The United States Government will exhibit a standard postal car built by the Pennsylvania, and loaned by the railroad to the Post Office Department during the Exposition.

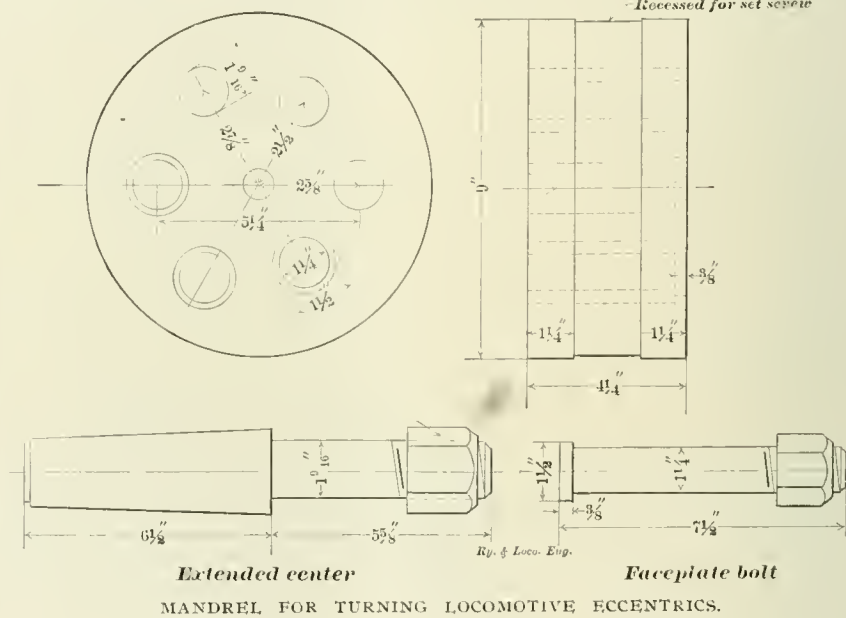

Extended center
Faceplate bolt
MANDREL FOR TURNING LOCOMOTIVE ECCENTRICS.

Louis World's Fair this year. The space to be occupied in the transportation building will be 33,000 sq. ft. of floor surface. That is equal to about 11 3/4 lawn tennis courts put side by side, but it only equals the heating surface of a little over six of those Santa Fé decopods which we illustrated in June and July, 1902. Each of those engines has about 5,300 sq. ft. of heating surface. The Pennsylvania have made an appropriation of about \$100,000 to meet the expenses of the exhibition.

In addition to the laboratory testing plant, which will be installed, and the De Glehn compound from France, there will be a 33 foot long model of the system of tunnels to be driven under Hudson River, Manhattan Island and the East River, connecting the Pennsylvania Railroad with the New York City and the

Wanted—A Train Order Holder in the Cab.

A serious accident occurred on the Canadian Pacific Railway a few weeks ago, which resulted in loss of life. A head on collision occurred at a place called Sand Point, which is about 59 miles west of Ottawa. The trains concerned were the two "Soo" expresses. The report of the accident as given in the daily papers was that the west bound train No. 7 had orders to meet the east bound train No. 8 at Sand Point, but that the engineer and conductor of No. 7 failed to remain at Sand Point, but went on and collided with No. 8 about three and a half miles beyond.

In giving an account of the accident the Montreal *Witness*, says: "Sir Thomas Shaughnessy, president of the company, was much concerned about the accident.

and ordered the fullest reports. Mr. C. W. Spencer, the traffic superintendent, in personally giving Sir Thomas an account of the accident, said that when two such men as the engineer and conductor of No. 7 could apparently be at fault, then one might feel like throwing up his hands, for they were two of the finest men in the service, who could be depended on to do their full duty."

This looks like a clear case of "forget," and in the light of this and similar fatal accidents which have happened all over the country to trains in charge of men with the best kind of record behind them, it seems as if some help to the memory ought to be devised. Both fireman and brakeman should receive copies of all train orders as well as the engineer and conductor. The fireman and the brakeman are supposed to be cognizant of the contents of all train orders, but

movement is concerned. Let the two junior men carry more responsibility and keep the vitally important order always before the eyes of the men on the engine.

Baldwin 4-4-2 for the Union Pacific.

The Union Pacific Railroad, of which Mr. W. R. McKeen, Jr., is superintendent of motive power, have recently received a number of simple fast passenger engines of the 4-4-2 type from the Baldwin Locomotive Works, of Philadelphia. The cylinders are 20x28 ins., and the diameter of the driving wheels is 81 ins. The carrying wheels at the back are 51 ins. in diameter. The driving wheel base of the engine is 7 ft., and the rigid wheel base, which is measured from the center of the forward driver to the center of the carrying wheel is 15 ft. 9 ins.

ins. at the back, and the crown sheet is parallel to it. The crown sheet is stayed with crown bars made out of steel T's and to the roof sheet similar T-bars are riveted with a system of sling stays between. The horizontal seams of this boiler are of the Vauclain pattern which is claimed to have 96 per cent. of the strength of the solid plate. It is a butt joint with double welt, the under one being diamond shaped. A detailed and illustrated explanation of this seam is to be found on page 337, August issue of RAILWAY AND LOCOMOTIVE ENGINEERING. The heating surface is arranged so that the fire box gives 179.8 sq. ft., and the tubes 2,475.1 sq. ft., and the total is 2,654.9 sq. ft. The grate in the wide fire box has an area of 49.5 sq. ft.

The tender has the Vanderbilt circular tank holding 7,000 gallons. The



ATLANTIC TYPE PASSENGER ENGINE, WITH VANDERBILT TANK, FOR THE UNION PACIFIC.

there is now on the majority of roads no official proof that they are so informed.

A suitable order holder could easily be made part of the cab equipment, which would enable the men on the engine to keep a meeting order in view, and if it happens that engineer and fireman are separated by reason of the style of the engine they are on, a train order holder could be supplied to each. We do not say that these suggestions, if adopted, would prove infallible in all cases, but they do not involve any great expense and are worth trying. As it is now the engineer and fireman read an order over, perhaps together, then it is usually put in the engineer's pocket and is completely out of sight after that, while both men turn their minds to the immediate work before them. The conductor is generally busy with the passengers—a most mind distracting kind of work—and the brakeman never has been looked upon as carrying much responsibility as far as train

The weight of the engine is distributed as follows: On the drivers are 106,590 lbs., which is called the adhesive weight. The front four wheel truck sustains 41,520 lbs., and the carrying wheels support 45,100 lbs. These added together give a total weight of 193,210 lbs. When the weight of the tender is taken into consideration the grand total runs up to about 323,000 lbs.

The valve motion is of the indirect type, the eccentrics being on the rear or main driving axle, the transmission bar encircles the leading driving axle, passing over the top, with bolt and filler below the axle. The driving springs are overhung and the rear pair are equalized with the carrying wheels by means of an equalizer having three pivot points, so that a readjustment of weight can be made in the shop if required at any time.

The boiler is of the straight top variety, 70 ins. in diameter, with wide fire box. The roof sheet slopes down

fuel space has sloped sides which keeps the coal always where the fireman can reach it. A few of the principal dimensions are appended for reference, as follows:

Valve—Balanced piston.

Boiler—Working pressure, 200 lbs.; fuel, soft coal.

Fire box—Length, 180 ins.; width, 65 ins.; depth, front, 65 ins.; depth, back, 64 ins.; thickness of sheets, sides, $\frac{3}{8}$ in.; back, $\frac{3}{8}$ in.; crown, $\frac{3}{8}$ in. tube, $\frac{1}{2}$ in.

Water space—Front, 5 ins.; sides, 5 ins.; back, 5 ins.

Tubes—Wire gauge, 0.125; number, 2,7; diameter, 2 ins.; length, 16 ft 0 in.

Driving wheels—Journals, main, 9x12 ins.; others, 9x12 in.

Engine truck wheels—Front diam., 33 $\frac{1}{2}$ ins.; journals, 6x10 ins.

Trailing wheels—Journals, 8x12 ins.

Wheel base—Total engine, 27 ft. 7 ins.; total engine and tend., 56 ft. 11 $\frac{3}{4}$ ins.

When we hear that heating surface is augmented in any particular type of engine, it is well to ask at which end of the boiler (front or back) the augmentation has taken place.

Buffet Car on the Chicago Great Western Ry.

The Chicago Great Western Railway have recently bought some very elegant passenger cars from the Pullman Company. The cars are represented by three types, first the express buffet, in which an express compartment occupies one end of the car with kitchen between it and an elaborate parlor in the other end. The buffet parlor has a first class compartment and a parlor, these are separated by a kitchen. Lastly the café parlor car which has kitchen at one end, café compartment next, parlor compartment next and smoking and observation compartment at the rear end.

Our illustrations are of the express buffet car and they serve to show the type of car which the passenger department has running on day trains between St. Paul, Chicago, Des Moines and Omaha. This car, No. 142, is mounted

wire screens, while the ornamental curved form used inside and the open brass work opposite each ventilator produces a pleasing "dome" effect. The sofa at the far end of the compartment has a locker under it in which pillows, etc., can be kept. The general appearance of the car inside is exceedingly handsome and when it is remembered that a well appointed cuisene is "part of the programme" on this road, traveling on the Maple Leaf Route may be made a most enjoyable experience, and one long to be remembered.

Old Time Railroad Reminiscences.

BY S. J. KIDDER.

As a prelude to this article I was thinking of saying something about how it seems to get "fired," but I guess many of my engineer readers have experienced such impromptu removal from active service sometime or other, hence will not

do was to accept it as a closed incident and hie himself away in search of another job.

I had been running an engine on the road ten years or more and during that period extremely good fortune had attended me, for I had never been laid off—this was before the days of merit and demerit marks—censured or even stood "on the carpet" and had every reason to believe that the way I had performed my duties—you know we owned our engines in those days—my job was secure so long as I cared to retain it. Subsequent events, however, proved that my fancied security was delusive and that the general manager was after me so precipitantly that a letter of dismissal was too slow, so he sent the verdict by telegraph.

I was pulling passenger on the Eastern division and on the day in question came into Burlington on No. 4, arriving there at 10 P. M. My return left



EXPRESS BUFFET CAR, CHICAGO GREAT WESTERN RAILWAY.

on two six wheel trucks in which every wheel is braked. It is 79 feet long over all and 9 feet 8 inches over the sheeting. The forward or express end has no platform, the end construction being made very solid. The rear platform has the ordinary passenger vestibule. The car weighs 94,900 lbs., and is equipped with very convenient lockers and ice boxes below the car floor.

The interior view shows the style of decoration which has been followed. The parlor compartment, which occupies more than $\frac{2}{3}$ of the car, is carpeted throughout and the drawing room effect is heightened by the polished table in the center with the quaint center lamp, and the various kinds of chairs which line both sides. The car is lighted both by electricity and gas. There is at the far end an electric fan, which is the joy of all travelers, especially in warm weather. The arrangement of the clear story is interesting. Outside its walls are verticle and the ventilators are provided with ordinary

attempt to recount the sensations incident thereto as they, no doubt, are of a somewhat painful sameness regardless of whether the recipient has by acts of commission or omission contributed to his forced retirement or not.

As suggested in a former communication I propose relating an incident which was one of the biggest surprises ever experienced during my railroad career for when I got fired it came like a Kansas cyclone, out of an apparently cloudless sky, with no intimation that such was in prospect and the victim did not even have a suspicion that his forced retirement from the company's service was being considered or that he had done, or failed to do, anything meriting the special solicitude of the general manager.

It happened years ago when, as a very general rule, little or no redress could be obtained against the arbitrary rulings of a railway official so inclined and when the verdict was rendered, without the victim being given an opportunity to even present his side of the case, all he could

the following morning at 6:40, and when I awoke somewhat later than that hour and learned the call boy had not left a call for me thought nothing of it, supposing I was being held in for some special service—something, by the way, not at all unusual.

Rolling over I took another nap, then got up, performed the usual morning ablutions, ate breakfast, then sauntered down to the railway shops. Passing through the roundhouse I noticed my engine was gone and that the shopmen and others I passed eyed me in a curious way which particularly attracted my attention. Walking along I entered the roundhouse foreman's office and, as I did so, he looked up, passed the time of day, then handed me a telegram addressed to the master mechanic reading, "Discharge ———— for insubordination," under which was the signature of the general manager.

To say that I was surprised is to express it but mildly and the foreman noticing my discomforture inquired

“Take Time By the Forelock”

Have things in such good shape that you'll come in on time, week after week, and not trail through the yard at the tail-flags of a suburban local.

Have pins and journals and eccentrics so well lubricated that they can't get hot. Have the air equipment so smooth that you can stop when you please, and therefore “speed her up” with confidence.

In other words—Have a can of *Dixon's Flake Graphite* with you when you oil up and get the benefit of all its marvelous lubricating value.

Less Coal.

Half the oil.

None of the trouble of the old way of doing things with oil alone.

Profit by the experience of others as set forth in Booklet 69c. Write for it and a free sample, and see an end of friction troubles.

**JOSEPH DIXON
CRUCIBLE CO.
Jersey City, N. J.**

what was the matter, to which I replied I did not know.

“Did you have your headlight covered last night when you met No. 1?”

“Yes; I attended to that myself.”

The general manager had gone west on that train and the foreman thought possibly I had been caught neglecting the rule to always cover the headlight when on a side track.

“Had trouble with your conductor or any one else?”

“No,” said I.

your job isn't secure on this road with your record, the rest of us might as well pack our grips and be prepared to get out at a moment's notice.”

Reaching the master mechanic's office I stepped up to his desk and said: “Mr. West, what am I discharged for?”

“Don't you know?” said he.

“If I did I would not be here asking you.”

The emphatic manner I replied to his question caused him to quickly comprehend that he had touched a tender spot



DRAWING ROOM COMPARTMENT, EXPRESS BUFFET CAR ON CHICAGO GREAT WESTERN.

“Can't you think of anything that has gone wrong or that they could get after you for?”

“No; everything has been moving along in a perfectly smooth channel and I haven't the slightest idea why they are on my trail, but will go down and see what the old man knows about it.”

Again passing through the engine house on my way to the master mechanic's office I met several engineers who were discussing my case and who wanted to know what the trouble was, but of which, of course, I was unable to enlighten them. “Well,” said one, “if

and he immediately took measures to placate me by remarking that all he knew about it was the telegram, and supposed I knew.

“Well, I don't,” said I, “but before departing from this particular neighborhood will endeavor to find out.”

My next call was on the assistant superintendent of the division, with whom I was on very friendly terms. Entering the office I intimated a desire to talk with him and was invited to a seat after which I remarked that he no doubt suspected the nature of my mission.

“Yes,” said he, “and I will tell you. It

has been reported that you laid off several weeks, some time ago, for the purpose of working up a spirit of dissatisfaction among the engine men and that you have frequently been seen riding on Illinois division engines to get those men to join with ours in creating a strike on the road."

"That is news, indeed," said I laughing, "but who gave this information?"

"That I am not at liberty to disclose," he replied.

"Pretty good evidence," I remarked to prove the falsity of the assertion, for when facts are dealt with the author does not desire his name concealed.

"I did lay off at the time you mention, having an affection of the throat, which prevented my speaking above a whisper, and during the time I neither left the house or had a conversation with any one connected with the road."

"As to riding on Illinois division engines," I continued, "I was at the river bridge one evening and as the engine of No. 1 came along I jumped aboard and, standing in the gangway rode through the yard, alighting before the train reached the station. During the time I did not converse with the engineer or fireman, and that is the only time I ever rode on an engine of that division in my life."

We discussed the subject at considerable length and finally the superintendent complimented me on my long, faithful and efficient service and remarked he wished there were more like me.

"Well," said I, "it must be confessed that I fail to comprehend the company's appreciation of my work when no opportunity is afforded me to protect myself and I am summarily fired by telegraph so that my discharge is made public from one end of the line to the other."

I next inquired when Vice-President Potter would return and found he was not expected for nearly three weeks. Well, I'll wait and possibly something will develop about that time. Mr. Potter was among my early acquaintances on the road and a man who meted out equal and exact justice to all. The superintendent sat for a moment in thought then wheeling in his chair said: "You had better take a vacation."

"I have already got one," I ventured to remind him. Continuing he said:

"I will get you passes to go wherever you wish and when Mr. Potter returns will see him and you shall hear from me shortly after."

"That is hardly necessary, for I am quite able to plead my own case."

"True," said he, "but you do as I say and every thing will come out all right."

"Very well," I answered, and a few days later, supplied with the biggest deck of passes I had ever carried. I was off on a two weeks' swing round the circle.

The day after Mr. Potter's return I dropped into the master mechanic's office, which, by the way, was but two blocks from that of the vice-president, and was handed a telegram reading: "Reinstate _____ at once," signed T. J. Potter, Vice-President.

Long after the superintendent related to me his conversation with the vice-president at the latter's home, on the Sunday morning before my reinstatement.

Upon stating that I had been discharged the vice-president inquired: "What for?" "I told him and," said the superintendent, "I have seen him mad many times, but never to the extent of that morning." "It's a d--d lie," said he. "Take a telegram and see that it is sent first thing in the morning. I will make his reinstatement as public as was his discharge." And the day after that telegram was handed me the 245 rolled out of the Union station with its long-time engineer again holding down the seat box.

Now, to this day I have never known positively what was the basis of my discharge, but in putting this and that together there was but one logical conclusion. Several months before a new division superintendent had been appointed, he coming from another road, and among the peculiar orders issued by him was one to the effect that dispatchers would be relieved from directing the movement of freight trains, such trains to be run on their time card rights. As east bound trains had the right of road they made pretty good time, but with three to six sections to each of these trains, stringing along from five to forty-five minutes apart, it was no unusual thing for west bound trains to suffer frequent and extended delays which could have been very largely avoided had the train dispatcher been permitted to help them along. In some instances west bound trains were 24 hours or more making the 75 mile division and when they reached the terminal the engines were immediately turned and sent to the yard, not infrequently waiting several hours for their train, the enginemen meantime being obliged to remain with them. While this state of affairs was going on a constantly increasing feeling of unrest was developing among the engineers which finally culminated in a meeting at which I was delegated to call on the general manager and verbally present the grievances to him and simply ask for their correction.

It might be here stated that no overtime was allowed, no matter how many hours were consumed in making a trip or for delays waiting for trains at division points, and all the men asked for was that the dispatchers be permitted to resume their former method of assisting trains to get over the road and that the engines be allowed to remain in the

GOLD CAR HEATING AND LIGHTING COMPANY

Catalogues and Circulars Cheerfully Furnished

MAIN OFFICE
FRANKFORD AND CLIFF STREETS
NEW YORK

BRANCH OFFICE
THE ROOKERY
CHICAGO

Manufacturers of ELECTRIC STEAM AND HOT WATER APPARATUS FOR RAILWAY CARS

Are You Prepared?

Don't wait until the day of examination comes, but send immediately for the following books—

Study Them and Your Promotion is Assured.

15TH EDITION OF Air Brake Catechism

Just issued. By Robert H. Blackall. Entirely rewritten, revised and enlarged. Contains 1,500 Questions and their Answers on the Westinghouse Air Brake, which are strictly up-to-date. Includes two large Westinghouse Air Brake Educational Charts printed in ten different colors. The latest practical work published. Endorsed and used by all Air Brake Inspectors and Instructors in the United States. Send for a copy and get posted on How to Handle Air Brakes. \$2.00.

Locomotive Catechism

By Robert Grimshaw. 23d Edition. Is right up-to-date and contains twelve large Folding Plates and 1,600 Questions and Answers on How to Run a Locomotive. The Standard Book on the subject, being written in plain language and free from mathematical formulae and complex problems. Endorsed by all Railroad Journals. Price \$2.00.

Combustion of Coal & the Prevention of Smoke

By Wm. M. Barr. Contains over 800 Questions and their Answers on The Science of Steam Making. Price, \$1.50.

Locomotive Breakdowns and their Remedies

Just issued. By Geo. L. Fowler. Tells how and what to do in case of an accident or breakdown on the road; includes special chapters on Compound Locomotives. Better procure a copy so you will be able to cope with any accident or breakdown. Price, \$1.50.

NEARLY READY

New York Air Brake Catechism

By Robert Blackall. The only complete treatise on the New York Air Brake and Air Signaling Apparatus, giving a detailed description of all the parts, their operation, troubles, and the methods of locating and remedying the same. Including and fully describing and illustrating the Plain Triple Valve, Quick-Action Triple Valve, Duplex Pumps, Pump Governor, Brake Valves, Retaining Valves, Freight Equipment, Signal Valve, Signal Reducing Valve, and Car Discharge Valve. 200 pages. Price, \$1.25.

These books contain many Questions and their Answers asked by the examiner on your road, so don't put off until examination day comes, but get them now. Send for a special circular describing the books in full. Any book sent prepaid on receipt of price.

Agents Wanted. Write for Particulars.

The Norman W. Henley Publishing Co.
132 Nassau St. New York, U. S. A.

roundhouse until a seasonable time before they were needed, thereby giving the enginemen an opportunity for rest.

To my written request for an interview the general manager replied that if the men had any grievances the proper way to present them was through the master mechanic, in other words via the old, slow, exasperating red tape method. This I reported to the men and having done all that had been delegated to me retired from further effort.

My temporary exclusion from the pay car proved a blessing in disguise for the obnoxious orders were canceled forthwith, making it possible for the men to make a round trip daily with plenty of time for rest, incidentally relieved the freight yards of frequent congestion and instigated an order that no engine should be sent to the freight yards until 30 minutes before the train was ready to leave.

As for myself I suffered the only discharge of my life; drew full pay for the entire time I was on the black list and, so far as I know, had an experience en-

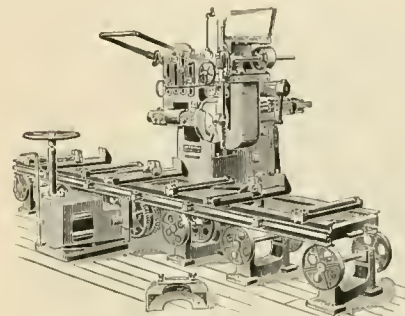

NO. 3 EXTRA LARGE AUTOMATIC CAR GAINING MACHINE.

tirely new and novel to locomotive engineers, that of drawing pay from a railroad company for services not actually rendered at so much a mile.

No. 3 Extra Large Automatic Car Gainer.

We are pleased to show our readers a cut of a new and improved Gaining Machine for car shops, patented January 30, 1900:

The machine is very powerful, simple in construction, and has a greater range and capacity than any other gainer now on the market. It possesses so many features and points of advantage to facilitate making adjustments and assuring accurate work that we call attention to a few:

It is designed for hard work, with capacity for timbers 16 inches thick and 20 in width. It has three speeds of feed, for narrow, deep and wide gaining. The gaining head moves forward and backward automatically and stops at each end of stroke, which can be varied to 22 inches wide. The head has a vertical movement of 15 inches, is under instant control of operator, and is so built that

it will make a clean cut whether feeding forward or backward. A feature of this head is that it will open to work twice its width. A 1½-in. head will cut a gain from 1½ to 3 ins. wide. Special heads for gaining to 6 inches can be furnished.

The carriage is strong and light, has a feed of 100 feet per minute, and through lever in front, is under instant control of operator. Stops are provided for regulating distances between gains. A boring attachment can also be furnished with the machine.

The makers of this gainer, J. A. Fay & Egan Co., of No. 445 West Front street, Cincinnati, Ohio, will be pleased to furnish any further information on request, will send cuts showing it and other machines, and will also forward, charges prepaid, their new catalogue, showing every machine they make.

Not long ago we recorded the fact that some of the little puffers formerly used on the New York Elevated road had been overhauled and had been painted yellow and had Chinese hieroglyphics put on their tanks—which lettering always remind one of a “celestial” washing bill. Now we have to record the fact that five large passenger coaches have just been built by the Wason Company for shipment to China. These coaches are similar to those used in this country except that they can be taken apart and packed for shipment. They each have hieroglyphics on their letter boards. It may be that over in China our little “L” puffers will help to show these Wason cars what the Celestial Empire looks like, and help to keep the “open door” policy in good working order.

Young graduates of scientific colleges who think they have learned everything worth knowing are noted in their writings for the use of positive adverbs. As they grow in experience they become less positive and veterans in science who have been schooled by experience to acknowledge the prevalence of error are noted for the frequent use of modifying clauses and expressions of uncertainty in their statements. A positive statement is attractive to unthinking readers, but positive people make many mistakes.

On January 10, last, a case of malicious train wrecking, near Booneville, Mo., caused the death of Engineer W. Trogley. The Denison division, No. 177, of the Brotherhood of Locomotive Engineers unanimously passed a resolution condemning malicious train wrecking and pledging their order to endeavor to secure punishment of all train wreckers. The resolution is being passed by every division of the Brotherhood throughout the country.

Niles Cylinder Boring Machine.

Annexed engraving shows a Cylinder Boring Machine, made by the Niles Tool Works, Hamilton, O., is driven by direct-connected motor through Renold silent chains. The machine will take cylinders up to 37 ins. in diameter and 60 ins. long. The boring bar which is 10 ins. in diameter is provided with various sizes of interchangeable cutter heads traveling on the bar by hand and variable power feeds. The bar may be traversed out of the work by moving the tailstock by ratchet. Speed change clutch levers are conveniently located for the operator, and with a range of speeds in the motor enables a very quick and close adjustment to the desired speed. It is driven by a Bullock electric motor. The machine is provided with double-facing heads.

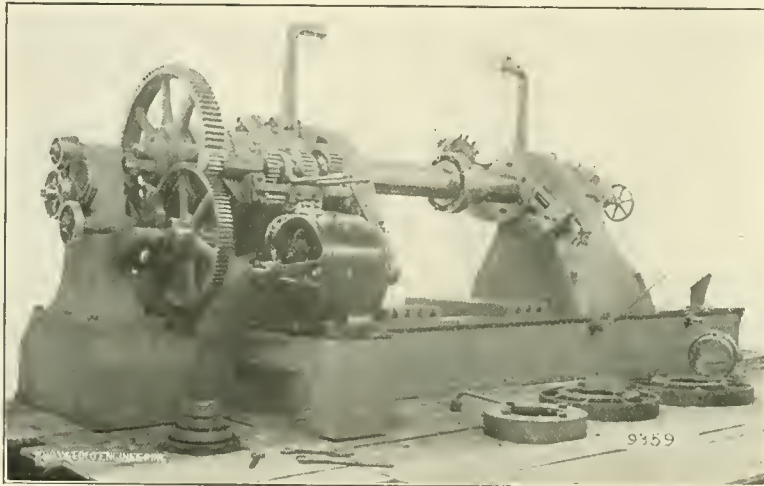

NILES CYLINDER BORING MACHINE.

Speaking by the Book.

There is a rather curious expression that you will sometimes hear a public speaker make use of when he is endeavoring to give some facts or statistics from memory. If he does not want to be tied down hard and fast by what he says he will probably remark, "I am not speaking by the book." He means by that, that if he had the book he would give his audience absolutely accurate information. You see that there are two things implied in the use of this expression, first that the speaker has a good, working knowledge of his facts, and second, that a book by a competent author is regarded as an authority upon the subject treated, or at least something upon which a good argument can be based. Under the circumstances verification is possible as soon as the book in question can be referred to. The good, working knowledge of facts, of which we speak, can only be gained by reading books, and when you do read, it is always advisable to select those which are authorities on the sub-

jects with which they are concerned. Now, we believe we can give you books which will enable you to gain the good, working knowledge of railway and locomotive engineering, and if you possess the book you can easily verify your facts. Here are some of them:

The first on the list is, of course, **RAILWAY AND LOCOMOTIVE ENGINEERING**, a practical journal of railway motive power and rolling stock. It costs only \$2.00 a year, and is well worth the money, and besides the paper is a welcome visitor in every household. Let your wife and children see it.

"Locomotive Engine Running and Management," by Angus Sinclair, is an old and a universal favorite. A well-known general manager remarked in a meeting of railroad men lately, "I attribute much of my success in life to

the inspiration of that book. It was my pocket companion for years." We sell it for \$2.00.

"Practical Shop Talks." Colvin. This is a very helpful book, combining instruction with amusement. It is a particularly useful book to the young mechanic. It has a stimulating effect in inducing him to study his business. The price of it is 50 cents.

"Examination Questions for Promotion." Thompson. This book is used by many master mechanics and traveling engineers in the examination of firemen for promotion and of engineers likely to be hired. It contains in small compass a large amount of information about the locomotive. Convenient pocket size. We cordially recommend this book. The price is 75 cents.

"Compound Locomotives." Colvin. This book instructs a man so that he will understand the construction and operation of a compound locomotive as well as he now understands a simple engine. Tells all about running, breakdowns and re-

Keep Your Mind On It

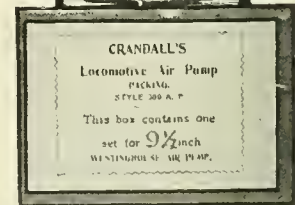

**CRANDALL'S HELIOS
AIR PUMP and
THROTTLE VALVE**

PACKING

Put Up in Sets
Exact Fit to Rod and Box
Send Trial Order

The Crandall Pkg. Co.
123 Liberty Street
N. Y. CITY

Chicago Office, 30 La Salle St.



**Over One
Thousand
Miles
A DAY**
on
"The Colorado Special"

Dinner in Chicago Today
Breakfast in Omaha Tomorrow Morning
Dinner in Denver Tomorrow Evening

**SPLENDID TRAIN SERVICE
to DENVER via UNION PACIFIC**

Full information cheerfully
furnished on application to
G. P. and Tkt. Agt.,
Omaha, Neb.

**THE NEW BARRETT
GEARED
RATCHET LEVER JACK**



**30 Tons Lifting
Capacity.**

An improved **QUICK-ACTING JACK** for the rapid handling of loaded freight cars, Pullman cars and all heavy loads. Has the simplicity of an ordinary Lever Jack, the leverage being specially compounded to permit **EASE of OPERATION** and **QUICK-ACTION**. No complicated features. Cannot get out of order. Send for Special Bulletin "L" and further information.

MADE EXCLUSIVELY BY

The Duff Manufacturing Co.,
Works: Allegheny, Pa. **PITTSBURG, PA.**

BOSTON & MAINE RAILROAD

**LOWEST RATES
Fast Train Service**

BETWEEN

**BOSTON and CHICAGO
ST. LOUIS, ST. PAUL
MINNEAPOLIS and all points
West, Northwest, Southwest**

**Pullman Parlor or Sleeping Cars on all
Through Trains.**

For tickets and information apply at any principal ticket office of the Company.

D. J. FLANDERS BOSTON
Gen'l Pass. & Ticket Agt.

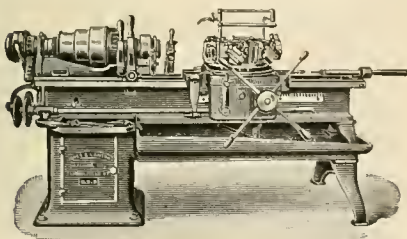

JONES & LAMSON MACHINE CO.

Main Office and Works:

SPRINGFIELD, VERMONT, U. S. A.

A, B, C and Lisber's Code used.

British Office: Jubilee Buildings, 97 Queen Victoria St., London, E. C. France and Spain: Ph. Bonvillain, 6, Rue Blanche, 6, Paris, France. Germany, Belgium, Holland, Switzerland and Austria-Hungary, M. Koye mann Charlottenstrasse 112, Dusseldorf, Germany.

pairs. Convenient pocket size, bound in leather, \$1.00.

"Catechism of the Steam Plant." Hem-enway. Contains information that will enable a man to take out a license to run a stationary engine. Tells about boilers, heating surface, horse power, condensers, feed water heaters, air pumps, engines, strength of boilers, testing boiler performances, etc., etc. This is only a partial list of its contents. It is in the question and answer style. 128 pages. Pocket size. 50 cents.

"Care and Management of Locomotive Boilers." Raps. This is a book that ought to be in the hands of every person who is in any way interested in keeping boilers in safe working order. Written by a foreman boilermaker. Also contains several chapters on oil-burning locomotives. Price, 50 cents.

"Locomotive Link Motion." Halsey. Any person who gives a little study to this book ceases to find link motion a puzzle. Explains about valves and valve

"Standard Train Rules." This is the code of Train Rules prepared by the American Railway Association, for the operating of all trains on single or double track. Used by nearly all railroads. Study of this book would prevent many collisions. Price, 50 cents.

"Mechanical Engineers' Pocket Book." Kent. This book contains 1,100 pages 6 x 3/4 inches of closely-printed minion type, containing mechanical engineering matter. It ought to be in the bookcase of every engineer who takes an interest in engineering questions. We use it constantly as a reference for questions sent to us to be answered. Full of tables and illustrations. Morocco leather, \$5.00.

"Locomotives, Simple, Compound and Electric." Reagan. An excellent book for people interested in any kind of locomotive. It will be found particularly useful to men handling or repairing compound locomotives. It is the real locomotive up to date. \$2.50.

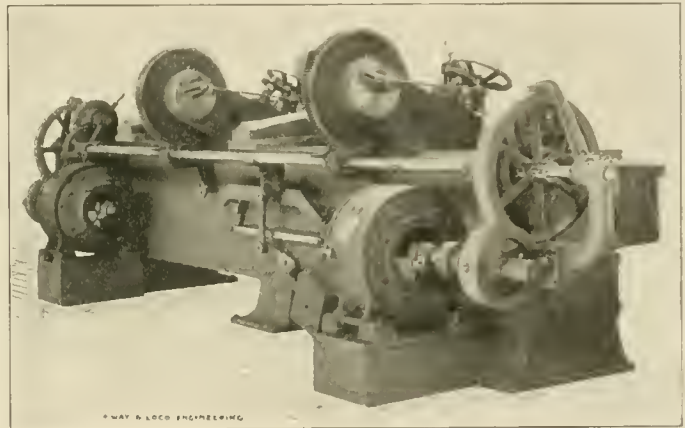

DOUBLE HEADED SHAPER.

motion in plain language, easily understood. Price, \$1.00.

"Machine Shop Arithmetic." Colvin and Cheney. This is a book that no person engaged in mechanical occupations can afford to do without. Enables any workman to figure out all the shop and machine problems which are so puzzling for want of a little knowledge. We sell it for 50 cents.

"Firing Locomotives." Sinclair. Treats in an easy way the principles of combustion. While treating on the chemistry of heat and combustion it is easily understood by every intelligent fireman. The price is 50 cents.

"Skeevers' Object Lessons." Hill. A collection of the famous object lesson stories which appeared in this paper several years ago. They are interesting, laughable and best of all they are of practical value to-day. \$1.00.

"Stories of the Railroad." Hill. Best railroad stories ever written. Those who have not read these stories have missed a great literary treat. \$1.50.

RAILWAY AND LOCOMOTIVE ENGINEERING. Bound volumes. \$3.00.

Mr. Geo. W. Taylor has been appointed Master Mechanic of the Cedar Rapids Division of the Chicago, Rock Island & Pacific Railway, vice Mr. J. H. Stubbs, transferred. The position of superintendent of the Cedar Rapids locomotive and car shops has been abolished, and the authority of the master mechanic of the Cedar Rapids Division has been extended over these shops.

Mr. W. J. Lawrence, formerly superintendent of the Cedar Rapids Division of the Chicago, Rock Island & Pacific Railway, has been appointed fuel agent for the system.

The Cincinnati Shaper Co.'s Double Headed Traverse Shaper.

The annexed cut shows the Cincinnati Shaper Company's electrically-driven double head Traverse Shaper, which has been installed in the shops of the Locomotive & Machine Co., of Montreal,

Can., being one of two machines thus equipped, the other being a 24-in. double-head machine, and one of four placed there, the other two being belt driven shapers.

This machine is operated by two Westinghouse motors, arranged for a two-voltage, three-wire system, rating at 3 and 6 h.p. at 115 and 230 volts respectively. The variation in speed of machine is obtained through variations in the motor and also by back gear on the machine, which may be seen through the large gear wheel on one of the two splined shafts at back of the machine, this large gear wheel being driven by pinion mounted on the motor shaft.

The two heads on the Traverse Shapers are driven independently, one from each end of the machine, and as they

volving driving wheels when the operation of valve setting is going on, will appreciate the arrangement shown in the annexed engraving in which the power from a pneumatic drill is used to operate the well known Sherbourne rotating mechanism. To a shopman who is interested in valve setting the picture needs no description. Those who do not understand it are not of sufficient consequence to waste description on. The apparatus is sold by Sherbourne & Co., Boston, Mass.

Bulletin No. 16, issued by the Union Switch & Signal Company, of Pittsburgh, Pa., is a very neat reprint of the description of their signal equipment exhibit room and demonstrating apparatus in the general office of the com-

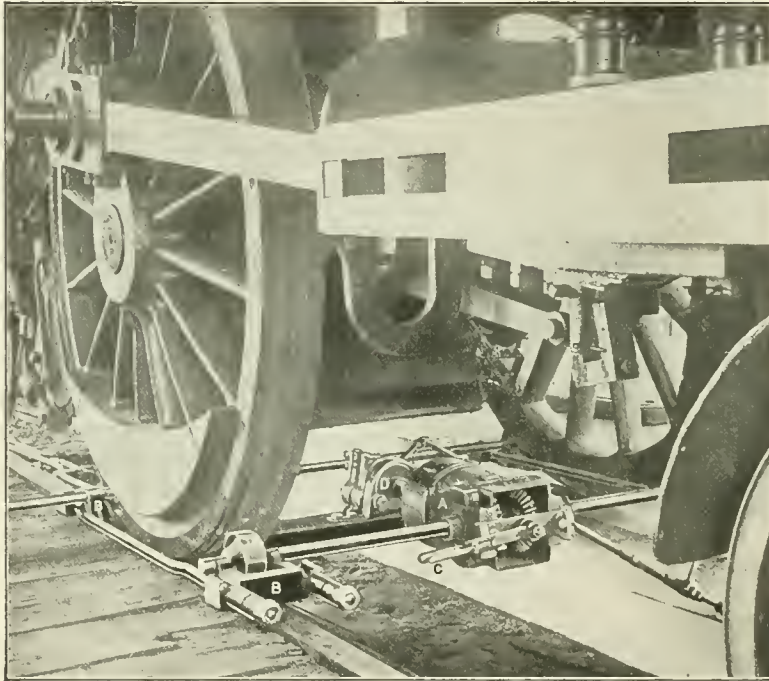

WHEEL ROTATING APPARATUS.

are arranged to work at any point along the bed, it is necessary that they travel past the center; but owing to the length of the splined driving shaft, by which the heads are driven in a machine of this length, the makers have provided a support at the center of the bed for the splined shaft, which is clearly shown and have made this support to be depressed automatically when either head is passing the center of the bed. The arrangement is very clearly shown in the cut. In the machine in question, the travel of each saddle is 118 ins., and the maximum distance from the tools 144 ins., the minimum distance 26 ins. The weight of the machine is about 14,000 lbs.

Wheel Rotating Apparatus.

Those who have had to wrestle with the various old fashioned methods of re-

pany at Swissvale, Pa., which appeared in the January, 1904, issue of RAILWAY AND LOCOMOTIVE ENGINEERING, under the title of "A Signal Success." There are two good half tones printed in the bulletin, which show the tracks and signals and the "Demonstrator Express" making a trip.

Monett Educational Club.

On the Frisco System, at Monett, Mo., they have a Railroad Men's Educational Club. A short time ago the club met in the Y. M. C. A. hall and listened to an address by Mr. J. J. Whyte, an engineer on the Southwestern division. The speaker took up the subject of "combustion." Mr. Whyte, after being introduced to the club by the president, Mr. W. O. Pellam, began by describing the formation of

H. S. PETERS'
BROTHERHOOD OVERALLS

have gone to almost every part of the World where Overalls are worn and are everywhere conceded to be the **BEST**. Every point of material, cut, construction and finish is carefully looked after; the only way that superiority can be attained. Every garment is absolutely guaranteed. The Patentee, Fleece-lined, Safety Watch Pocket is alone worth a whole suit of any other make.

I'll send sample suits, charges paid, to any place in the World where mail or express goes, where I have no retail agency; sample materials and full particulars for the asking.

UNION MADE
OF COURSE —
B.L.F. 3—H.S. PETERS—BLE. 171
DOVER, NEW JERSEY, U. S. A.

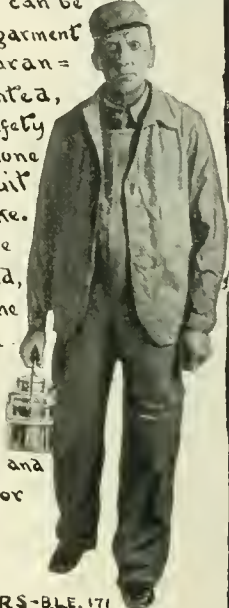

The Twentieth Century Master Mechanic

Won't use solid Mandrels. Cost too much, take up too much room and don't give satisfaction.

Nicholson Expanding Mandrels

Take everything from 1 to 7 inch holes. Take up little room—always ready and you can buy four sets for the cost of one of the solid kind.

Are You Using Them?

Catalogue tells you more about them.

W. H. Nicholson & Co.
Wilkesbarre, Pa.

Ball's Official R. R. Standard Watches

16 AND 18 SIZE.



17 AND 21 RUBY JEWELS, SAPPHIRE PALLETS

BALL'S IMPROVED SAFETY DOUBLE ROLLER

Are without question the finest watches that American talent and skilled labor can produce, and they are giving such universal satisfaction that we have no hesitancy in claiming that they are the best and safest railroad watch on the market.

Tests severe and numerous have proven this fact to the most critical users in all sections of the country, to which thousands of good Railroad and Brotherhood men are ready to certify.

We have an authorized agent in nearly every railroad center. Call on him for information and facts. Write us for descriptive matter.

The Webb C. Ball Watch Co.

Watch Manufacturers

Ball Building, Cleveland, Ohio, U. S. A.

Handy Folding PILOT COUPLER

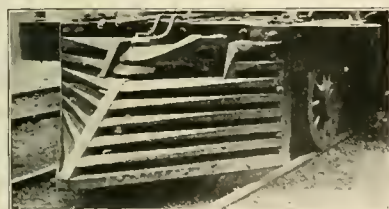

A safe and neat construction for front ends of road locomotives

Handy Car Equipment Co.

Old Colony Building
Chicago

THE ROBERT W. HUNT & CO.

Bureau of Inspection, Tests and Consultation,
1137 THE ROOKERY, CHICAGO.

66 Broadway, New York. Park Building, Pittsburgh
31 Norfolk House, London, Eng.

Inspection of Steel Rails, Splice Bars, Railroad Cars, Wheels, Axles, etc. CHEMICAL LABORATORY—Analysis of Ores, Iron, Steel, Oils, Water, etc. PHYSICAL LABORATORY—Test of Metals, Drop and Pulling Test of Couplers, Draw Bars, etc.

Efficiency Tests of Boilers, Engines and Locomotives.

coal in the earth. He explained the action of air, rain and snow on coal exposed to the atmosphere and followed with a statement of what happens when the coal gets into the fire box. He took up the subject of depth of fire, draught, the cause of clinker formation and altogether gave a useful and instructive address.

At the meetings of this educational club the book of rules is occasionally the subject for explanation by the trainmaster of the division, and various other subjects relating to railroad operation are taken up from time to time. Such lectures as that given by Mr. Whyte cannot fail to do good, and the men are to be congratulated on the formation of a club for educational purposes.

adjustable automatic stop brings the slide to rest at any point of the stroke. A safety lever prevents the clutch being thrown in gear except through the use of the foot or hand lever, thereby preventing accident through premature starting of the cam shaft. Provision is made for taking up wear in slide through tapering gibs and the face plate. An open front punch holder provides for removal of the punch stock or adjustment of same.

The machine is made by the Long & Allstatter Company, Hamilton, Ohio.

The Cleveland Twist Drill Company of Cleveland, Ohio, have issued a neat little brochure on "Twist drills; their use and abuse." The object which the company have in view in issuing this

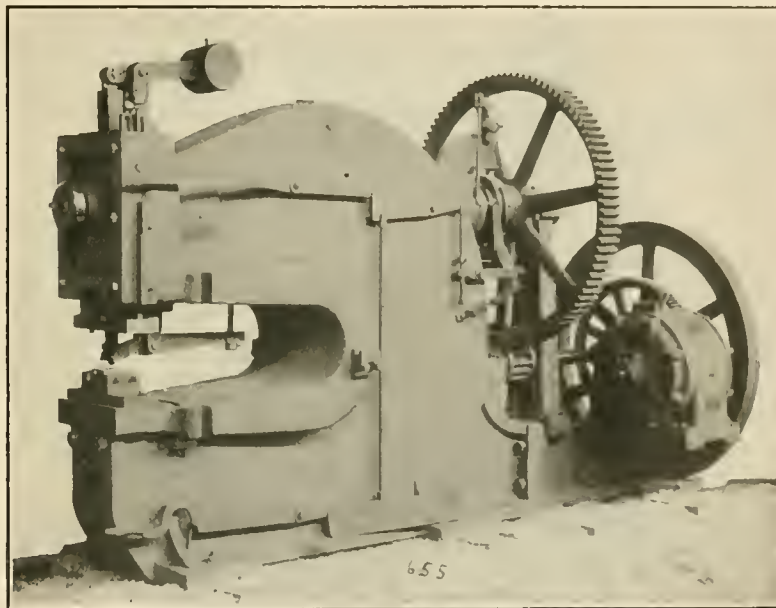

PUNCHING AND SHEARING MACHINE.

Punching and Shearing Machine.

Annexed engraving illustrates a single punching and shearing machine with 36-in. throat, driven by a 7½ h.p. induction motor.

The lower jaw is made with a removable block, increasing the scope of the machine's work so as to punch the flanges and webs of I-beams, channels, angles, etc. When this removable block is out the die block overhangs, providing room for the lower flange, while the upper flange rests on the die. The web can be punched with the same tools.

When the removable block is in place all other tools for plates and bars—for splitting, cross cutting and punching—can be used the same as on a regular machine.

Machine has steel forged cam shaft—steel faced clutch jaws—and steel forged stripper, foot and hand levers. The slide is spring weight balanced. An

little publication is to present to their friends a brief but comprehensive collection of ideas concerning twist drills, and these ideas are based on their own experience and observation. It is hoped that the perusal of the reading matter, which, by the way, is very fully illustrated, will assist users of twist drills to obtain an increased cutting capacity combined with durability of the drill. Along the margin the heading for each paragraph is printed in bold type, which facilitates reference to any article. Technical words or phrases have been eliminated as far as possible, and the work is easy to understand and should be very useful in any shop where twist drills are used. If you are interested write the Cleveland Twist Drill Company.

The Wabash at the St. Louis Fair.

The passenger department of the Wabash Railroad has issued a very handsome folder giving information

concerning the "Universal Exposition, St. Louis, 1904." The folder may be had by writing for one to Mr. C. S. Crane, general passenger and freight agent, at St. Louis, Mo., or to any of the numerous local passenger agents of the Wabash in any of the cities or towns along the line.

A description of what is called the greatest world's fair in history, is given, with the significant sub-title, "processes rather than products." The folder is illustrated in clean and well executed half tones, showing the various buildings and views of the grounds. There are two colored plates, one a plan of the exposition grounds and the other a plan of that part of St. Louis which surrounds the grounds. The Wabash line, with city

table is $37\frac{1}{2}$ ins. in diameter, is powerfully geared, and has ten changes of speed. The teeth on both table and pinion are accurately planed. The heads are entirely independent in their movements, both as to direction and amount of feed. They can be set at any angle and carry the tool bars, which have a movement of 19 ins. Either head can be brought to the center for boring. The feeds are positive, have ten changes, and range from $\frac{1}{32}$ to $\frac{3}{4}$ of an inch horizontally, and from $\frac{1}{50}$ to $\frac{1}{2}$ an inch in angular and vertical directions. The cross rail is raised and lowered by power. The cone has five sections for $2\frac{1}{2}$ in. belt, the largest being 18 ins. in diameter. A brake and belt shifter are both provided as shown. The countershaft has two pulleys 14 ins. in diameter, for $4\frac{1}{2}$ in.

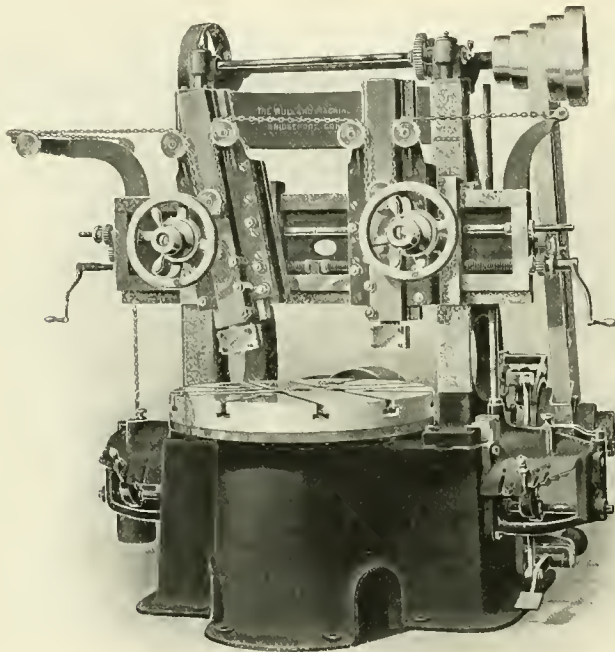

BULLARD BORING AND TURNING MILL.

terminal and station near the exhibition, is clearly shown. This latter station is illustrated by a large half tone insert, and a plan with minute description on the last page. The folder contains a good general line map of the United States and border portions of Canada and Mexico. On this map the line of the Wabash Railroad is traced in a bright, red line. The folder will be most useful to those desiring information concerning what is officially known as the "Louisiana Purchase Exposition," at St. Louis, Mo.

37 Inch Boring and Turning Mill.

The annexed engraving shows the 37 inch boring and turning mill made by The Bullard Machine Tool Company, Bridgeport, Conn. The capacity is 42 ins. in diameter and $32\frac{1}{2}$ ins. in height. The

belt, and should run 400 revolutions per minute, forward.

A "Pocket" Test Gauge.

The Ashton Valve Company, of 271 Franklin street, Boston, have recently got out an extremely handy appliance in the shape of a standard pocket test gauge, which has been used by a considerable number of air brake inspectors, boiler inspectors, master mechanics, shop men, etc. It is a neat, light, little gauge so made that it can be carried in the pocket, hand bag, or otherwise, without danger of injury. It has a bevel plate glass front and is fitted with a metal cover which completely protects the glass.

This standard test gauge, like all the other Ashton gauges is made of solid drawn seamless tubing, and it has a

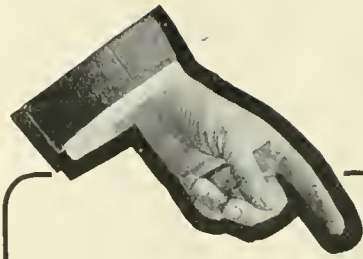

Better Belt Service ^A

Cling-Surface is a filler and preservative for belts, making and keeping them pliable, elastic, waterproof, preserved.

It stops slipping entirely, allowing all belts to run easy under fullest loads.

It is not a sticky belt dressing.

Used by Pa. R. R., D. L. & W., P. & R., D. & H., Iowa Cent., N. Pacific, A. T. & S. F., American, Rogers, H. K. Porter Locomotive Cos.; American Car Co., Carnegie and Westinghouse Cos., and many others.

Order on approval. We guarantee it. Ask for book, "New Knowledge on Belt Management."

Cling-Surface Mfg. Co.
Virginia Street Buffalo N. Y.
Branches in leading cities

JUST PUBLISHED

—THE— LOCOMOTIVE UP TO DATE

The greatest accumulation of new and practical matter ever published treating upon the construction and management of modern locomotives, both

SIMPLE and COMPOUND

By CHAS. McSHANE

Author of "One Thousand Pointers for Machinists and Engineers," Special Exhaustive Articles were prepared for this new book by the

Baldwin Locomotive Works
Rogers Locomotive Company
Schenectady Locomotive Works
Pittsburg Loco. and Car Works
Brooks Locomotive Works
Dickson Locomotive Works
Cooke Loco. and Machine Co.
Richmond Loco. and Machine Co.

With contributions from more than one hundred prominent railway officials and inventors of special railway appliances.

736 Pages, 6x9 Inches 380 Illustrations
An Absolute Authority on All Subjects relating to the Locomotive

Bound in Fine Cloth, \$2.50

ONE THOUSAND POINTERS

—FOR— MACHINISTS and ENGINEERS

By CHAS. McSHANE

(Practical Machinist)

Assisted by CLINTON B. CONGER, Air Brake Expert; J. P. HINE, Mem. Div. 37, B. of L. E.; J. G. A. MEYER, Mechanical Engineer; W. M. F. GOSS, Mechanical Engineer; JNO. C. WHITE, Indicator Expert. The only complete work on the locomotive combining both theory and practice. 342 pages, 187 illustrations.

BOUND IN FINE CLOTH, \$1.50

The only book ever endorsed by the International Association of Machinists. Agents wanted everywhere; write for terms, commissions and club rates. Will be sent prepaid to any address upon receipt of price.

GRIFFIN & WINTERS, Pub.
171 La Salle St., CHICAGO, ILL., U. S. A.

Patents.

GEO. P. WHITTLESEY,

McGILL BUILDING,

WASHINGTON, D. C.

Terms Reasonable. Pamphlet Sent

Do You Boil Glue?

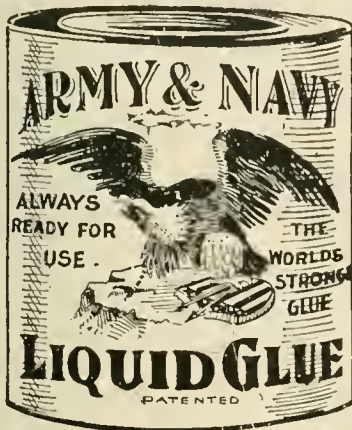

ARMY & NAVY LIQUID GLUE

does away with this work. A pure hide and sinew glue in liquid form. No smell; clean and convenient. Will reduce your shop expense for this line of work twenty-five per cent. **The Glue of the Twentieth Century.** Put up in cans, kegs and barrels.

Not a Fish Glue

Samples for testing and prices are yours for the asking.

WACHTER MFG. CO.
BALTIMORE, MARYLAND

non-corrosive movement. The diameter of the gauge is about 3 ins. and is graduated for any pressure up to and including 500 lbs. It is nickel plated and with cover weighs about one pound. The test gauge and a gauge hand puller for resetting gauge hands, makes a very serviceable outfit for those who have to do the important work of testing and caring for steam gauges. The Ashton people have issued a circular describing the pocket test gauge and will be happy to send the circular and quote prices to any one interested enough to them for it. Every air brake inspector and boiler inspector in the country ought to have one of these gauges. Send for price list.

The Becker-Brainard Milling Machine Company of Hyde Park, Mass., have issued a large plain calendar for the year 1904. The whole sheet is 24x18 ins. and the figure spaces are 2 by 1½ ins. so that the calendar is of use in a large room or factory. Write to the Becker-Brainard people if you want to get such a calendar.

The Standard Tool Company, of Cleveland, Ohio, has issued an exceedingly neat little calendar for 1904. It measures 11¾x8 ins., with monthly sheet, 6½x5¾ ins. The figures are clear and the whole calendar is artistic in appearance. Under the calendar pages there is some useful information concerning machine and hand taps, machine screw taps and pipe taps. Write to the company if you would like to get one of the calendars.

We are short of the July issue of 1903 and will credit subscribers who send us a copy with two current issues. Those who send us papers will please put their names on the wrappers for identification.

In our book review column in the February issue we stated that "Practical Lessons in Electricity" was a book of 63 pages. As a matter of fact, it was a book of 226 pages. It contains what may be called four chapters, each written by a separate author. The pages of the book are not consecutively numbered, hence our mistake. The book is sold at 70 cents, but the edition has been exhausted and a new and enlarged edition has been got out. The price of the book is now 90 cents.

Col. Jno. T. Dickinson, vice-president of the Consolidated Railway Electric Lighting & Equipment Company, General offices, Hanover Bank Building, New York, is authority for the statement that the Consolidated Company has more of its "Axle Light" equipments of electric car lighting in use on

the best cars constituting the finest trains of leading railway lines than all other systems of electric car lighting combined. Also, that the chief mechanical officials of several of the great railway systems in the country, where a large number of "Axle Light" equipments have been in service for the past few years, have concluded that Consolidated "Axle Light" is the cheapest to install and maintain and the most efficient system of electric car lighting ever yet devised. Each car carries its own independent electric car lighting apparatus, ready for immediate and constant use, no matter in what service the car may be placed.

A very neat little catalogue has been issued by the Crandall Packing Company of Palmyra, N. Y., whose New York City office is at 123 Liberty street. The list of the various forms in which the Crandall packing is made is quite large, and many of them are illustrated on the pages of the catalogue. An alphabetical index at the beginning of the book accounts for 59 separate varieties, and each one of these represents several sizes. Though the size of the rings be different, for the variety of kinds is large, yet the quality remains uniform throughout. The style shown on page 28 is especially designed for air pumps and throttle valves on locomotives, and is furnished in sets for steam and air ends of pumps. It is made the correct number of coils to exactly fill the depth of the stuffing box. It is easily applied and is handy for emergency repairs. Write the company for a copy of the pamphlet on Crandall packing if you are interested and want to know something of a product which is made in more varieties than those of a famous brand of pickles.

The McCord Axle Box.

The McCord axle box has several unique features which should commend it to railroad officials and to the men who work on the repair track. In the first place the box is made of malleable iron and if it becomes dented or battered it is not necessary to scrap it on that account. The box can be hammered into shape again and is as good as ever.

The lid, while conforming to the M. C. B. Association requirements, "goes them one better," so to speak, in that the lid is made tight and kept tight by the presence of a lip on the inside which fits down over the lower edge of the box opening. This "fitting down" is accomplished by means of a slotted hole for the hinge bolt by which hinge bolt and cover slip down when the box is closed and the lip on the inside of the cover engaging with the edge of the box holds

The essential features of design of our . . .

Water Softening Apparatus

and minor details as well appeal strongly to technical men

Industrial Water Company
126 LIBERTY ST., NEW YORK

the box lid tightly shut. The opening of the box is done by slightly lifting the lid. The lifting motion is one which would naturally be made by a car oiler when opening the box for oil or waste. The spring cover on the lid fits tightly over the boss in the center of the box and when the lid is shut, a lip which is on it, slips down with the whole lid and fits into a groove in the boss, thus making a dust proof cover on all four sides.

The dust guard consists of three pieces. There is a malleable iron casing ring which slips over the axle and is held to the box by a couple of loosely fitting lugs cast on the back corners. There is also a gray iron ring which fits closely to the axle and is held in the casing ring by a couple of turns of spring wire. The dust guard

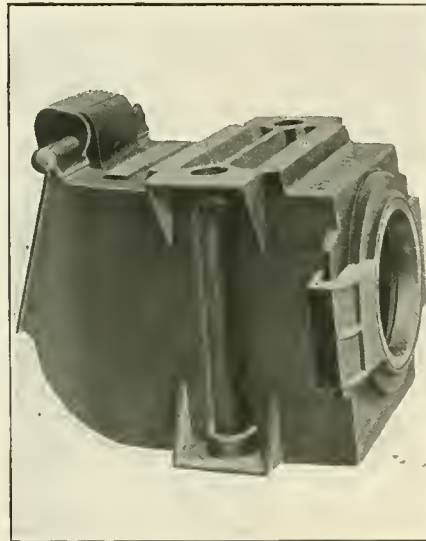

MCCORD AXLE BOX, SHOWING METAL DUST GUARD.

casing ring has a machined face which fits closely against a machined face on the box. An up and down and a side motion of the dust guard is secured, together with absolute dust proof contact between box and guard at all times, due to the pressure of the spring. The parts are few and can only be put together in one way. A box with this dust guard and the McCord lid is a box, the inside of which does not know what dust means, and its wearing and lasting qualities are of the best.

A new volume of the decisions of the arbitration committee of the Master Car Builders' Association has been issued and is for sale by Mr. Joseph W. Taylor, Secretary of the Association, Rookery Building, Chicago, Ill.

LOCOMOTIVE ENGINEERS AND FIREMEN

Wanted to buy December, 1899; February, 1900; September, 1902 issues Railway and Locomotive Engineering. Address H.R. Newcomb, 200 Woodward, Detroit, Mich.

Besides **ASHTON** LOCOMOTIVE STEAM GAGES



WE MAKE
Duplex Air Gages
Gage Testers
Blow-off Valves
Chime Steam Whistles
Pop Valves

ALL OF A SUPERIOR QUALITY

Catalogue L on Application

The Ashton Valve Company, 271 Franklin Street Boston, Mass.

American Locomotive Sander Company

13th & Willow Sts., Philadelphia, Pa.

Proprietors and Manufacturers,

LEACH, SHERBURNE, DEAN, SANDERS
HOUSTON, "SHE" and CURTIS



Moran Flexible Steam-Heating Connection, All Metal. . .

ESPECIALLY APPLICABLE BETWEEN ENGINE AND TENDER.

MORAN FLEXIBLE STEAM JOINT CO., Inc.

No. 149 Third Street, Louisville, Ky.

CONTENTS.

	PAGE.
Air Brake Department.....	123
"Collision Energy Line".....	123
Hose, Evils of a Dragging.....	123
*Valve, New York Air Brake Co.'s Compensating.....	124
*Appliance, Shop, for oil barrels.....	122
*Automobile, Extraordinary Speed of, By Angus Sinclair.....	121
Bells and Whistles.....	118
Boiler Explosions.....	116
Boiler, Hot, Does not Cause Explosions.....	103
Book Reviews.....	119
*Car, Builet, for Chicago Great Western Ry.....	118
Cars, Motor, for Surface Railways.....	108
Color, What Is?.....	109
Correspondence.....	110
Expansion, Locating Defects of.....	108
Expansions, Railroad.....	108
Explosions, Boiler, 116; Hot Boiler Does Not Cause.....	103
Law, Move to Modify Interstate Commerce.....	130
*Link Motion, Real Inventor of, By W. L. Campbell.....	128
Locomotives.....	103
*Louisville & Nashville 4-6-0.....	103
*Freight Power for Queen & Crescent.....	105
*Old Locomotive "Philadelphia".....	109
*Atlantic Type for Central of England.....	131
Locating Defects in Schenectady Cross Compound.....	110
Slipping Shut off, of.....	112-113-115
Memory, Strains on.....	103
*Machine Tools.....	147-148
Ogden to Lucin Cut-Off on Southern Pacific.....	132
Personals.....	133
Publicity Better Than Secrecy.....	130
Questions Answered.....	120
Railroad Expansion.....	108
Railroads Ought to Cultivate Timber Growing.....	109
Railway Policy, New Canadian.....	118
Shipping of Locomotives Shut off.....	112-113-115
*Signals and Signaling, By George S. Hodgins.....	113
Speeds, Fictitious High, 110; *Extraordinary, of Automobile.....	121
Standardization.....	118
Stories and Narratives.....	109
"Last Call for Dinner in the Dining Car," By A. O. Brookside.....	102
Old Time Reminiscences, By S. J. Kidder.....	138
Timber Growing, Railroads Ought to Cultivate.....	109
Tools, Rating Machine.....	117
*Tube, Expansion Machine.....	106
*Tunnel, The Radehaugh, on the Pennsylvania.....	101
*Valves, Setting Inside Admission Piston, By Ira A. Moore.....	105
Winans, Work of Ross, By C. H. Caruthers.....	106

Hydraulic

Riveters—Fixed and Portable.
Punches, Shears,
Presses, Lifts, Cranes
and Accumulators.

**MATTHEWS' FIRE HYDRANTS
EDDY VALVES,
VALVE INDICATOR POSTS.**

The Camden High-Pressure Valves.

Cast Iron Pipe.

R. D. Wood & Company
Engineers, Iron Founders, Machinists,
400 Chestnut St., Philadelphia, Pa

... THE ...

CHAPMAN JACK SCREW.

PATENTED.

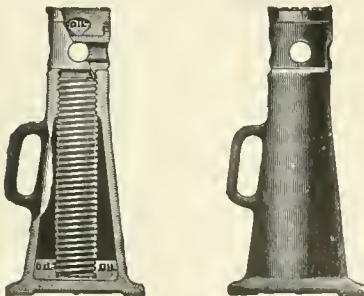

Always Lubricated and Ready for Use.

THE CHAPMAN JACK CO.
CLEVELAND, OHIO.

Railway and Locomotive Engineering

Copyright by Angus Sinclair Co.—1904

A Practical Journal of Railway Motive Power and Rolling Stock

Vol. XVII.

174 Broadway, New York, April, 1904

No. 4



R'WAY, & LOCO. ENGINEERING

A COMPOUND LOCOMOTIVE ON A HEAVY PULL.

Rogers Engine for the N., C. & St. L.

Our line engraving of a passenger locomotive illustrates one of the four which Mr. F. H. Scheffer, superintendent of machinery of the Nashville, Chattanooga & St. Louis Railway has recently received on behalf of his company, from the Rogers Locomotive Works, of Paterson, N. J.

The engines are simple 4-6-0 passenger machines, with 19x26 ins. cylinders and 66 in. driving wheels. The boiler carries 200 lbs. pressure. The calculated tractive effort is about 24,170 lbs. The center pair of wheels are the main drivers, and the valve motion is indirect, with rocker, its arms being above and below its center. The transmission bar is a

on fast freight work when necessary as well as in passenger service.

A few of the principal dimensions are appended for reference:

Cylinders—19x26 ins.

Driving Wheels—Diam., 66 ins.; axles, material; steel; journals, 8x11 ins.; wheel base, 13 ft. 0 in.; total wheel base of engine, 23 ft. 9 ins.; weight on drivers, 115,000 lbs.; truck, 31,000 lbs.; total engine, 146,000 lbs.

Heating Surface—Total, 2035 sq. ft.; grate area, 29 sq. ft.

Boiler—Thickness of barrel, $\frac{3}{8}$ in.; thickness of dome course, $\frac{3}{8}$ in.

Fire Box—Crown, $\frac{3}{4}$ in.; thickness, flue sheet, $\frac{1}{2}$ in.; thickness, sides and back, $\frac{3}{4}$ in.; grate, length, 123 ins.; width, 34 ins.; flues, number 264; thickness, 11 B. W. G.; length, 13 ft. 6 ins.; diameter, 2 ins.

Tender—In working order, weighs 102,000 lbs., trucks, diamond, cast steel bolster.

viction shall be fined \$1,000, or not more than one year's imprisonment or both. This shall not apply to any steam railroad which shall have had any tunnel or subway described herein in use for railroad purposes twenty-five years prior to January 1, 1905, the day when the law is to go into effect.

A Remarkable Train.

There will be grouped together in one train what may be called the history of railroad motive power for more than a century, when the Field Columbian Museum railroad exhibit will be coupled to a modern locomotive and drawn to a convenient shipping point for the St. Louis Exhibition.

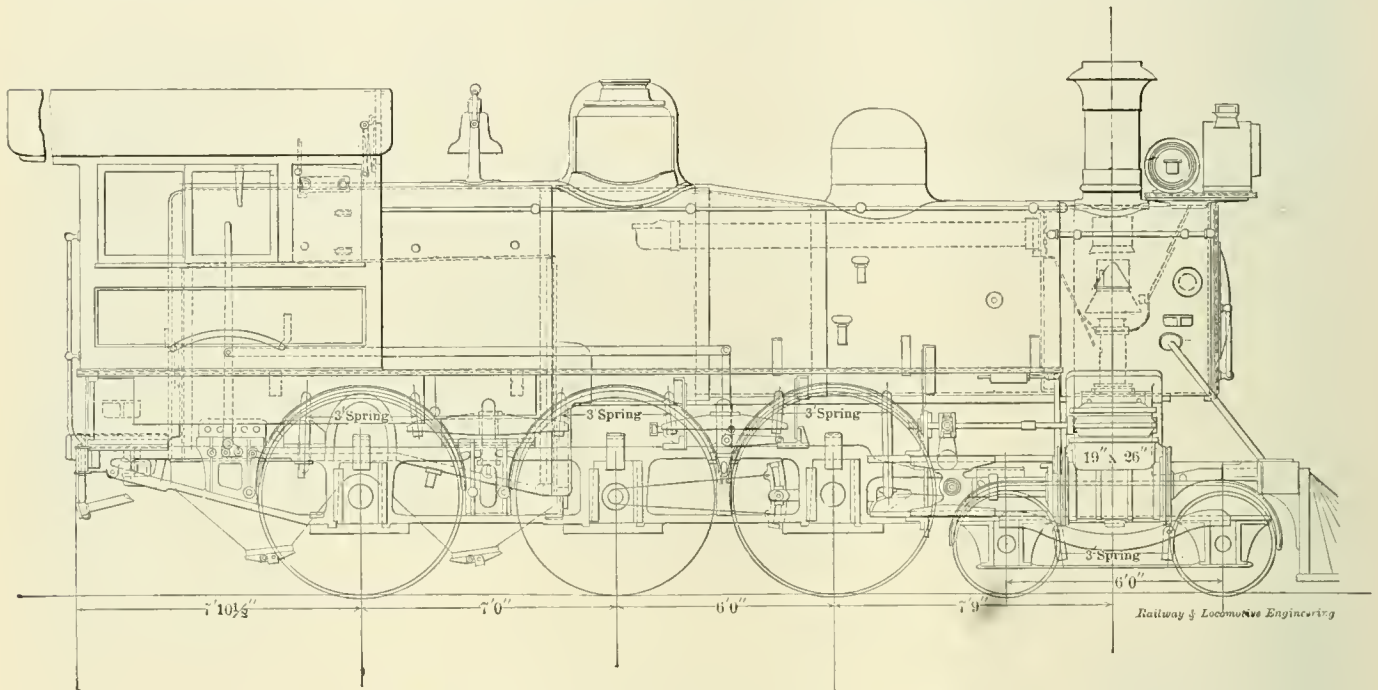

ROGERS TEN-WHEEL ENGINE FOR THE N., C. & ST. L.

steel casting which passes over the first driving axle in the form of an inverted Π , with a bolt and spacer between the open parts. All the wheels are flanged and all driving springs are overhung.

The heating surface contained in the boiler is 2,035 sq. ft. The flues give 1,866 sq. ft., and the fire box has 169 sq. ft. in it. The boiler is an extension wagon top type made of flange steel. The crown sheet is very nearly horizontal, having only a very slight fall toward the back, and the dome is set forward on the gusset sheet.

The tender frame is made of 10 in. channels, the tank holds 5,000 gallons of water and the fuel space holds 8 tons of soft coal. The weight of the engine is 146,000 lbs., of which 115,000 lbs. is carried on drivers, while the weight of both engine and tender in working order is about 248,000. The engine truck has the bolster suspended on three point hangers. The whole machine is a good, serviceable type of engine and can be used

Safety valves—2 ins. and $3\frac{1}{2}$ ins.; lubricator, triple sight feed; headlight, electric; brakes, automatic air drivers, tender and train; boiler covering, sectional magnesia; valves, balanced slide; cab, material, ash.

Politicians Want to Regulate Tunnel Operations.

The extensive introduction of underground railways in the neighborhood of New York is giving assemblymen their opportunity to make small political capital by introducing bills to regulate the working of these tunnels. It is wonderful how much small fry politicians think they know about railway management.

One bill recently introduced into the New York State Legislature provides all railways running through tunnels more than a mile in length must use steel passenger cars to be approved by the State railway commissioners. For violation a fine of \$500 per car is imposed and the directors of the companies are made guilty of a misdemeanor and upon con-

The Baltimore & Ohio exhibit, which was donated to the Field Museum at the close of the Chicago World's Fair, includes thirty-eight full sized working reproductions of locomotives covering a period from 1680 to 1848, and nine locomotives which were in actual use from 1832 to 1876.

The Chicago & Northwestern Railway are going to send the first locomotive used west of Chicago, the "Pioneer," and a reproduction of "Old Ironsides," the first locomotive built by Baldwin, will also be sent. The Illinois Central will lend the first engine used in the Gulf States, called the "Mississippi," and the Pennsylvania will contribute models of early cars and coaches.

We have no doubt that when the time comes "The General," now belonging to the Southern Railroad, and standing in that Company's Chattanooga, Tenn., station will also appear at St. Louis. This famous machine

when in the possession of the Western & Atlantic Railroad figured in the civil war as the engine which was stolen by the "Raiders," and which was so gallantly pursued and recaptured by the crew after a most exciting chase.

Suburban Tank Locomotive.

The Lancashire & Yorkshire Railway has recently put into working a new class of suburban tank locomotive, illustrated here, which promises to be a very successful engine for their heavy traffic on short lines. It is designed by Mr. H. A. Hoy, the locomotive engineer, of the L. & Y. R., and built at the Horwich Works, near Bolton. It is designed so as to be capable of obtaining rapid "acceleration" and of maintain-

Railroad, a little narrow gauge road about 20 miles long, running between the two places designated in the road's name. One of the stories is to the effect that in its busy days the general manager acted as engineer, fireman, switchman, train dispatcher and brakeman, and also filled several other official and subordinate positions. One of the results of this ideal state of affairs was that there was little or no friction between the management and "the men," though from another story which is told of this road, some of the departments were allowed to shamefully neglect their business. It is said that one night the round house at Forest City collapsed and so damaged all the motive power of the road at one blow

timers will have lay figures at the throttles, representing engineers garbed in the style and dress of the times in which they lived. The dummy engineers are to be made of appropriate materials. The skeleton of each is to be made of iron piping, and upon this, the rough shape required, will be achieved by the use of reed like fibers, and the final and definite form will be moulded in a superior sort of plaster of paris, mortar, something like that by which a modern engineer keeps his headlight glass in place. The costumes of the countries represented will be faithfully reproduced from the time of Newton, 1608, to the present day. We may have a chance to see the engineer of early days wearing a frock coat and a "topper" such as we are



2-6-2 TANK LOCOMOTIVE ON THE LANCASHIRE & YORKSHIRE.

ing a high average speed. The cylinders are 19 ins. in diameter, with a stroke of 26 ins., and have double ported valves; the radial leading and trailing wheels are 43 5/8 ins. in diameter and the six coupled wheels are 68 ins. in diameter, the total wheel base being 27 ft. 7 ins. The boiler is of large dimensions and has a total heating surface of 2,038.64 sq. ft. The coal bunker has a capacity for 3 3/4 tons, and the tanks contain 2,000 gallons of water, but in addition the engine is provided with a water scoop apparatus, which can pick up water when traveling in either direction.

A Railroad Poo Bah.

There are some funny stories told about the Forest City & Gettysburg

that traffic was entirely suspended until some blacksmiths could be brought in to repair it. While the locomotive was out of commission mules were used to haul the company's rolling stock from one end of the road to the other, over the two streaks of rust called the track, and then other mules brought both the cars back again. This road was recently sold to satisfy a mortgage, and then all the employees were discharged, and he packed up his things and went home.

Lay Figure at the Throttle.

The interesting announcement is made that the exhibit of the Baltimore & Ohio Railroad at the St. Louis Exposition, consisting of modern engines and old-

familiar with in the pictures and prints about 1850. The face coloring of these gas pipe "plug pullers" is said to be very lifelike and it is predicted that at 10 feet distance a spectator will be puzzled to tell whether he is looking at a flesh and blood engineer of to-day or a made up being from one of the preceding centuries.

A Reminiscence of the Early Sixties.

BY SHANDY MAGUIRE.

RAILWAY AND LOCOMOTIVE ENGINEERING, last November, made a request on anyone who had anything to do with pioneer locomotives to communicate the same. I can take an excursion back through memory's halls and can toss up out of the dust and cobwebs of

about 40 years, a few things relating to those days which are no more.

I was employed on a road 35 miles long. It had three locomotives, one a 12x22 in., another 13x24 in., and we looked upon the third as a leviathan, it being a 15x24 in. They were named respectively Vixen, Champion and Hercules. It is with the Vixen my story lies. It was a V hook motion, had two domes, the whistle on the forward one, put there presumably to extort Ave Maries from the heart of the delighted block tosser; a brass jacket all over, except the bands, which were of Russia iron; and all had to be cleaned every day. Many a heart felt prayer went up to the Deity to bless Commodore Vanderbilt for having the engines of the New York Central "Black Crooked" about the time of which I am telling. He got sick of jewelry.

A man named George Wendell was the engineer of the Vixen, and he was the beau ideal of one. He would step into the cab in as unsullied an appearance as Beau Brummel: laundried shirt, cuffs, broadcloth, and a silk hat constituted his daily wardrobe. There was no coal. There were very few engines, consequently but few engineers, and those were deified by spectators, particularly by the way station grangers. A son of the soil named Ed. Casey was Wendell's fireman. He was named "Flip" by his familiars from his continuous habit of saying "I'll flip a cent with you to see who'll buy it," and he rarely lost. He was a good fireman, which meant more as a cleaner than a block tosser. George thought a great deal of him, and as human nature was vastly more bigoted then than now, "Flip" couldn't hold his job but for Wendell.

George was under 30 years of age, single, a singer in the choir of a fashionable church, and he was considered a first rate catch by husband hunters, which were scattered around in those days just the same as they are to-day. The Vixen ran a passenger train of three coaches, not much bigger than present day cabooses, and the trips were made by Wendell as enjoyable as if they were being made over a private right of way, with continuous flower gardens on each side, for at many houses as he'd pass, he was well and favorably known, and his salutation was always responded to in a very friendly manner by the occupants.

One house in particular had a charm for George, for a very charming young lady used to come to the door to salute him, which was done in a sort of wig wag way, understood only by the interested parties. "Flip" wasn't the brightest child ever sent into the world, yet he fancied he could interpret a variation of the wig wagging at times,

which he kept to himself. They had four hours between runs every other day, and George's apparel would be more studiously arranged on the lay-over days than on the intervening ones, also, his absence from the engine house more prolonged.

One day, arrayed in his best, as he was passing the house of his apparently best girl, whose name was Carrie Preston, he varied up the salutes; "Flip" supposed she comprehended it. Miss Preston was a singer in the same church choir as George sang in. She was an estimable lady, and one to make any accepted suitor proud.

"How much steam have we, Ed?" said George, after they had run about two miles from the Preston house and were within three miles of the terminal.

"About 110," said Flip, who lifted the spring balance scales until he heard the escape of steam from the top of dome.

"Do not give her any more wood; we have enough in the fire box to take us in."

Flip jumped up on the seat to rest, and ring the bell at crossings. If enough of wood was brought in in the fire box after the trip was made, it had to be taken out with a tongs, so as not to waste the water, and have to reduce steam to run up with a hose, as there was neither an injector nor blower yet heard of on the road.

When they got to the end of the trip the agent had a car to place at the freight house, and there was no appeal. Before the notice had been given, George had divested himself of his overclothing. He had weak lungs, and was being treated with cod liver oil. He carried the bottle with him, so as to take a small dose regularly every hour. He was also prescribed the best whisky, a tablespoonful of which he was to take after any great physical exertion. He changed the cod liver oil bottle into his trousers pocket, thinking he would be kept out switching longer than he expected, for he knew the agent would shuffle every car in the yard once he got the engine out. It was a down grade to the freight shed where they were taking the car. It was gaining momentum rapidly, and George knew that no reliance could be placed on the pin puller to set a brake, so he gave a big yank to the lever to get the motion unhooked, and after he had succeeded it took possession and traveled from head to back in a continuous frolic until caught by Flip. Poor Wendell, from the unusual exertion, was prostrated on the deck, and the bottle of cod liver oil got broken. The odor was decidedly unpleasant. He tried to wipe out the stains from his clothing, but the odor remained, and when they

got back to the house after completing the switching, he had to use Flip.

"Ed."—he was too gentlemanly to call him Flip—"please get me half a pint of the best rye whisky, and I will be thankful to have you go to the parlor of the Tremont House, where you will find Miss Preston. Please tell her that owing to a mishap I am unable to keep my engagement with her to-day, but the day after to-morrow, if she observes me pass, I shall be at her service."

Off Flip started. He first got the bottle filled. It had an alluring look as he shot a glance through it at the sun. He had no money to buy himself a smile, and boarding masters, with bars, did not flourish then to give credit and fire the bills into the offices, duly itemized, as they do now, so he—took one swallow out of the bottle. He smacked his lips and called it good. He had another, for he knew one swallow never made a summer, and his stomach was decidedly wintry for a drink. It seemed that the two couldn't agree, so he sent down a third to keep them company, but when he saw the amount taken from the bottle he knew the jig was up, and he drank the remainder.

Half an hour later he walked into the parlor of the Tremont House with a swagger of "I don't give a damn," Miss Preston, pervading his whole swelled head. The lady received him in a very gracious manner, knowing he came from George. After salutations were over, which Flip was fain to prolong, Miss P. asked if he had any message for her.

"Yes; he told me to tell you that his engine broke down and he couldn't make out to keep his date with you to-day."

She gave him a peculiar look, and slowly said: "I think this is strange; I saw the engine getting wooded to return as I came by the engine shed."

"That's true for you; the Vixen is all right, but George isn't."

"What do you mean, Mr. Casey?"

"I mean that Wendell is now over in the Windsor, swapping kisses and lies with Kittie Munroe."

"Mr. Casey, I do not understand your language, and wish to close this interview."

"It is just as true as I am telling it to you. I didn't want to have a girl as handsome and accomplished as you are —"

"Sir! I appreciate all you intend to say about my personal appearance, but decline to listen."

A queen of tragedy could not make a grander exit than did the lady, leaving Flip nearer to being sober than when he entered the room.

They left at 6.10 on their return. Flip didn't show up till leaving time, and

Wendell knew that something was wrong. He had yet a fighting jag. He pulled up on the scales, then on the damper, so as to fill the cab with smoke and to keep George from questioning him. At last, after they got started, he asked: "What kept you, Ed.?"

"I was tagging Carrie Preston around Front street, where she was parading with Jack Parson, to keep tag on her."

"Wasn't she at the Tremont House?"

"Yes; the instant she saw me enter the parlor she said she was glad I came, as she was only waiting to tell you she could not remain with you any length of time, as she had very important business up town."

"Casey, you are lying and you are drunk. Where is the whisky I sent you for?"

second day after and he was met at the door by Carrie's mother. The first question George asked was if she was in.

"Yes, George; she is a little indisposed; I'll go and fetch her." In a few minutes they met. As they looked into each other's eyes they read constancy, truth, love and suffering. After explanations were given, George said: "I'll make Casey pay for this."

"You must not say or do anything to him, George. It was the whisky. You know you always liked him. No praise was too lavish for you to give him when his name was mentioned. He always had the good, willing hands to help you out in your physical condition; think of that, and also that he is a very young man, who is helping to take care of his widowed mother, and

"He is, but he ran to hide when he saw you approaching. He is in the room there, ashamed to meet you for some reason or other. Did you and he have any trouble between you?"

"Not any, Mrs. Casey. He got some bad whisky that did not agree with him and I reprimanded him too severely. I am here for your sake, as well as his, to get him to promise to quit drinking, and come out with me tomorrow. I have his absence from duty accounted for."

Ed. heard every word. He made a bound out of the room and gave his consent in the handclasp he gave him. Mrs. Casey lifted her eyes heavenward, saying: "May the God of the widow and fatherless ever bless you and be your stay in sickness and sorrow, should they ever be your portion, and give you

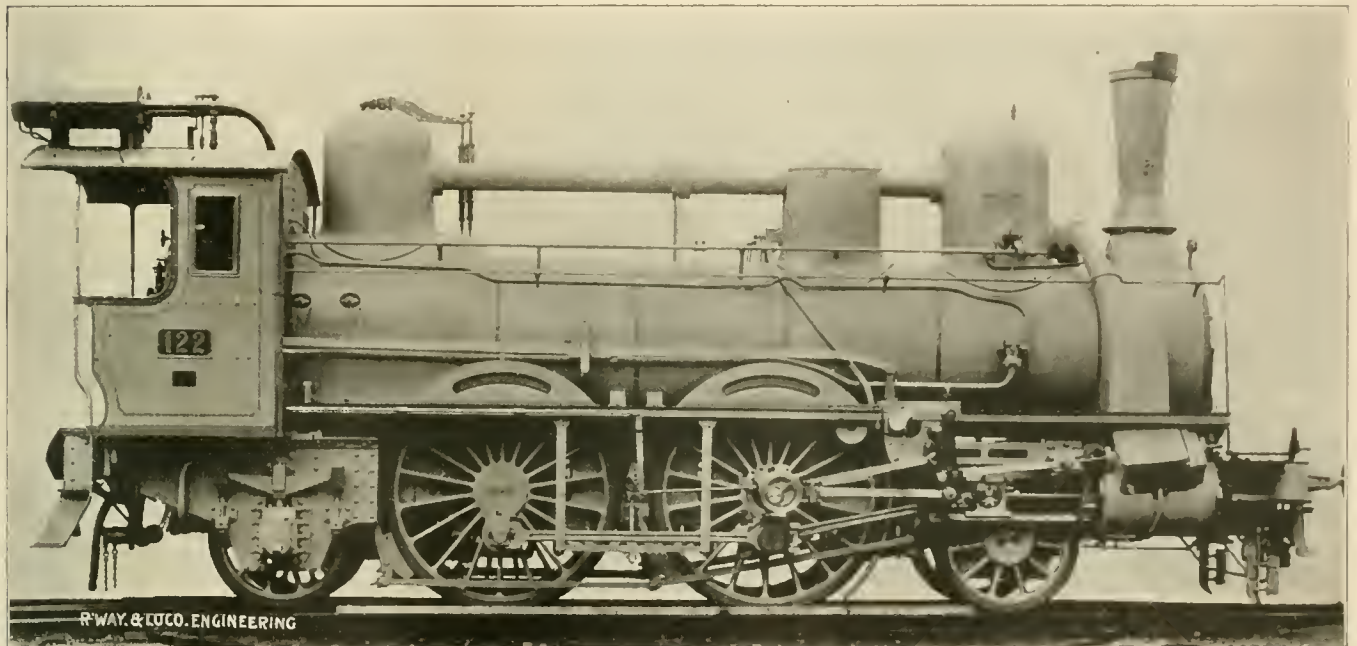

LOCOMOTIVE FOR AUSTRIAN STATE RAILWAYS.

"I threw it into Boyd's creek to razzle-dazzle the fish, for I charged it with causing you this humiliation with Jack Preston's haughty daughter."

Wendell ceased talking, which showed he was very mad. He was thinking laboriously, and the only conclusion Flip came to was that he was not through with the day's actions, for when Wendell was leaving the engine, he said: "Casey, you'll hear from me again about this."

Flip did not report for duty the next day nor the next. The truth is, the fellow was stricken with remorse when he found that he did not act properly with George Wendell, the best friend he ever had, and he kept trying to flood out his penitent thoughts in Mother Downey's shebang, gulping down her bad whisky.

George drove back to Preston's the

to educate his little sister, and for my sake take him in hand and save him from bad company and drinking."

The lady gained her wish. After he had supper that same night he went direct to Casey's house. The old lady admitted him. The poor soul did not know what sort of a mission he came on, and in frightful suspense she scanned his face; she could get nothing out of her son; she surmised they quarreled, and that Ed. was to blame.

"Good evening, Mrs. Casey," said George, in his heartiest manner, which did more to banish her fears than any other words he could utter.

"Good evenin' and God bless you, Mr. Wendell; I am glad to have you honor my humble home by your presence."

After a few commonplaces, he asked if Ed. was in.

the same joy your words give to my suffering heart, Mr. Wendell."

Casey drank no more liquor. A few weeks later Carrie Preston and George Wendell were married. After about seven years of a happy union he succumbed to lung troubles. He provided well for his widow and 5 year old daughter by life insurance. He also got Ed. Casey the train he used to run. He was buried out of the church to which he and his wife belonged. It was packed to suffocation the day of his obsequies. When they were concluded and the funeral director stated for all who wished to take a last look of the deceased ere the casket was closed, an old lady, modestly attired, came along with others, and when she reached the casket she rested her head upon her hands, gazing on the face of the dead. One loud sob escaped from her, which

penetrated to the remotest part of the edifice; then, in a voice trembling with the keenest emotion, regardless of rituals or rubrics, creeds or congregations, she said: "George Wendell, here your body lies; but may the good God who gave up his life to save souls, grant that yours may live forevermore in glory with Him, to reward you for the friendship you have always shown to me and mine."

It was Mrs. Casey, and the united "Amen" of the multitude was the response to her prayer.

Old Time Birkenhead Engine Still Pulling Trains.

Our engraving shows an honorable "old timer" still in passenger service on the Carillon & Greenville Railroad, in the province of Quebec, in Canada. This road is operated in connection with the

The throttle valve is an interesting piece of mechanism. It is a hollow brass valve of the plunger type, fitted into a cast iron cylinder. The cylinder is flanged at both ends, one flange is bolted to the inside of the back sheet. The forward end of this cylinder is bolted to the dry pipe, thus making a solid stay between back sheet and front flue sheet. Another pipe comes down from the top of the dome and connects with this cast iron cylinder, which supplies steam to the cylinders when the plug valve has been drawn back.

Two brass guides are attached to the stuffing box flange, of the inclined plane or wedge type. The throttle handle extends up through the guides, and as the engineer pulls the handle from left to right, the inclined plane guides force the valve from its seat and the pulling of the valve back, admits steam to the dry pipe.



OLD TIME "BIRKENHEAD," STILL IN SERVICE.

steamers of the Ottawa River Navigation Company. Mr. H. W. Shepherd is the president of the road, and Mr. John E. Halsey is general superintendent.

The engine was built in Birkenhead, England, more than 40 years ago, and performs her work at the present time to the satisfaction of all concerned, she is a good steamer and is very economical in fuel. The cylinders are 15x20 ins. and the driving wheels are 60 ins. in diameter. The cylinders are on the outside, but the valves are old fashioned D slide valves and are inside, and are so placed that the run on their edges, if one may so say.

The boiler is 48 ins. at the smoke box end. There are 180 brass flues $1\frac{7}{8}$ ins. diameter, each with a length of 10 ft. 6 ins. The fire box is 3 ft. 6 ins. by 3 ft. 10 ins. and is 4 ft. high. The fire box and boiler are both made of Low Moor iron. The flue sheet is $\frac{1}{2}$ in. thick, and the fire box sheets are $\frac{3}{8}$ in. thick.

The rigid wheel base is 7 ft. The total length of the engine is 21 ft. The tender is 17 ft. 6 ins., and the total length of engine and tender is 38 ft. 6 ins. This interesting locomotive is one of the oldest machines, if not itself the oldest, which is in active service at the present time.

A Slow Community.

In talking at a meeting of railroad men some years ago Senator Depew referred to the stimulating effect that railroads have upon every community which they touch. He said: "I don't like a man who stands still. I was brought up in a community where things stood still. It was the proper thing to stand still; it was undignified to move and was not good form. The horse which I first drove when I first used to go around the country practising law, was called Beeswax because he stuck to the ground, but he was considered highly respectable.

I remember when I was a student at Yale, on going home during holidays, I would go up to the grocery which was the center of the intelligent circulation of the town, and listen to the oracle of the village as he sat beside the stove. He thought he was a constitutional lawyer. He was constantly debating with the people who came in whether the powers of the Constitution permitted the Federal Government to exercise certain authority over the State. I said to him once: "John, such a provision of the Constitution gives this power to the Government." He said, "When I get home to-night I shall read that provision." Ten years after I was in that grocery store again, and the oracle sat in the chair alongside the stove. As I went in he was discussing the power of the general government over the States. Said I: "John, I think I have remarked to you in a recent conversation that there is a direct provision of the Constitution giving that power to general government." "Well," he said, "I have not had time since I saw you to look it up."

Where the Color Line is Tightly Drawn.

The Brotherhood of Locomotive Engineers on the Lehigh Valley Railroad displayed great indignation lately owing to a false report having been circulated that a colored engineer was employed on the road.

The story containing this false report was first published in Ithaca and was taken up by several papers in the State. When it reached the hearing of the officers of the fraternity it caused quite a sensation. As a matter of fact, not a single colored man is employed by the Lehigh Valley Company, either as engineer, fireman or brakeman.

In a meeting of the officials of the brotherhood this matter of the false report was discussed in rather angry terms. A delegation was sent to the official staff of the railroad company where the indignation of the fraternity was approved.

Never in the history of railroads has there been so many complaints about the failure of railroad companies during this winter to keep the cars at the ordinary comfortable temperature. This is a fair illustration of how demand increases with supply. The time was when a passenger car having two candles for light and a small stove for heat was spoiling the passengers by according them unreasonable luxuries. But the desire for comfort grew with the efforts to supply the most exacting wants of passengers, and now no excuse of bad weather or of accidents will induce travelers by railroad that anything less than the luxuries of the best hotels is due to them at all times.

The Plate Rack Idea in the Wheel Shop.

People who like to decorate their dining room walls with ornamental plates held in racks, are aware of the fact that in order to make a plate stand up pretty nearly perpendicular, the floor of the rack must have a slight groove cut in it or have a cleat fastened along so that the plate cannot slip forward on the rack and assume the position in which they would be useful if on the dinner table.

It has been reserved for the shop people at Reading, Pa., on the Philadelphia & Reading, to put this esthetic and artistic plate rack idea to prosaic but labor-saving use where they handle their cast iron car wheels. The floor of the shop is planked, and at one side on the floor is secured a stout timber, a little heavier than the outside sill of a wooden car. Against this timber a wheel is placed like a plate in an ornamental rack, and a piece of $\frac{1}{4} \times 1$ in. iron laid parallel to the timber and a few inches away from it, holds the wheel pretty nearly upright just as the cleat holds the plate in the rack.

When one wheel is thus secured another can be laid against it and another and another, all in the same nearly vertical position, until perhaps a dozen are side by side, like a stack of poker chips on edge. The nearly vertical position is of importance because it brings the axle holes all in line, and a piece of 3 in. shafting can be passed through the dozen wheels, and have six or eight inches projecting out at each end. The timber against which the first wheel leans is below the center, so that the shaft is able to project out at that end as well as at the other and a sling chain from an overhead crane can take hold of the projecting shaft ends and lift the twelve wheels at once and waft them away through the air to a flat car, which is to carry the load. But on the flat car the beautiful plate rack idea is abandoned and at each end of the full line of wheels a few are thrown down to a more comfortable angle, so that none will fall off, and the load cannot shift. By this means about 150 wheels can be loaded in about twenty minutes. New or old wheels can be handled in this way with great facility, and the economy in the shop makes as ornamental a showing on the company's ledger as the most beautiful plates could on a highly artistic rack.

Ten-Coupled Prussian Tank Engine.

The illustration which is here presented is of a ten-coupled tank locomotive for the Prussian State Railways, and the uniformed engineer and fireman are in keeping with government ownership.

The driving gear of this engine is probably the feature which an observer

would first pick out on looking at the general make up of the "foreigner." The pistons drive on the third pair of wheels in the usual way with side rod running forward and coupled to the second and first pairs.

There is a pin passing through the end of the main rod close to the crosshead, and entirely distinct from the wrist pin. This pin is attached to and gives motion to a rocker arm which stands above it. We say that this rocker stands instead of hangs because the upper or pivot point works up and down in a girder which is bolted to the metal running board.

About half way down this rocker a pin with sliding connection connects with a rod which gives motion to a similar rocker the top of which shows in the recess visible in the center of the tank. The lower end of this second rocker is the little end of a second connecting rod which drives on the fourth pair, with



TEN-COUPLED TANK ENGINE, PRUSSIAN STATE RAILWAYS.

side rod to the fifth pair in the usual way.

The forward rocker is pinned to the front connecting rod and though the rocker is pivoted so as to be a lever of the second class, yet it slides up and down at the pivot point and the horizontal driving rod has a knuckle joint about half way along its length.

Another curious feature is that this locomotive carries a spare connecting rod on each side. Four connecting rods are in use when the engine is working and opposite the lower end of the central rocker there is a hanging brace bolted to the frame which carries one end of the spare connecting rod and the other may be seen where it is bolted to the parallel brace outside the wheels.

Russian Railway Schools.

Every day the influence of railroads in promoting education is becoming more and more apparent. Until railroad companies began to require certain educational attainments in the peo-

ple they employed, there was scarcely any sentiment among employers of labor in favor of education; but as soon as railway companies took the lead many others followed their example, and educational tests before employment is given to young men have become almost universal. There is no civilized country where ignorance among the masses has prevailed to such an extent as it has done in Russia, but now, even the subjects of the Czar are being drawn into the educational column with railway men in front.

A recent number of Harper's Weekly says: The railway schools of Russia are among the most interesting of all nations. When the great Siberian Railway is completed it will form a practical westward continuation of the American trunk lines, connected by international ferries in the form of gigantic steamship lines. It was the construction of the wonderful Siberian

Railway which largely liberalized all Russia and turned its attention to the education of children. At the latest report Russia was teaching 6,000 children of railway men all branches of modern railway construction and operation. Russia recently sent two eminent ministers of affairs to this country to examine the workings of the railway branches of the Young Men's Christian Association for the immediate introduction of the service at division points of the railways of all Russia.

The Ninth Biennial Convention of the Brotherhood of Locomotive Firemen, whose membership in the United States, Canada and Mexico is over 54,000, will be held in Buffalo, from September 5 to 26, 1904. While the number of delegates will be only about 700, the visiting members of the order during the three weeks' session are expected to swell the number to 20,000 at least.

Work of the Pennsylvania Railroad in New York City.

The Pennsylvania Railroad Company is carrying on stupendous tunneling operations in working their line under the Hudson river to the heart of New York City. Mr. W. H. Baldwin, Jr., president of the Long Island Railroad, gave a public address recently in which particulars were given of the great engineering work which the Pennsylvania Railroad is carrying out. In connection with tunneling under the Hudson and East rivers, Mr. Baldwin said that the tubes forming the tunnel had to be carried on screw piers.

These screw piers are only used in passing through the very deep silt beds of the North river. While a tube, resting unsupported in the silt, might be built which would carry ordinary trolley traffic, it was quite another matter

breadth. These piers will be in the neighborhood of 15 ft. all the way across the silt tract in the river bed. In other words, the tunnels practically are built on a bridge deck, and this bridge deck is supported on the piles.

Experiments with the piers have been going on for a year and have been tested up to 600,000 pounds. They will give, Mr. Baldwin said, absolute solidity and safety to the tunnels. The total length of the single track tunnel will be seventeen and a half miles and twenty-four miles will be the total tunnel trackage exclusive of the Manhattan underground station and yards, in which there will be eight miles of trackage.

The total weight of the cast iron in the entire tube tunnels will be 200,000 tons, and of the concrete with which they are to be lined there will be 700,000 cubic yards. The amount of exca-

laborious way as the regular railway bills have to be. Often in car repair or mileage bills a great deal of correspondence takes place because the biller wants money at "your earliest convenience" and the "billee" does not see it exactly that way, and would like an explanation and more details.

As there are about 1,088 roads in the United States, pretty nearly all of them billing a large number of what each calls a foreign road, it is evident that the clerical work necessary to carry on the business is very great. Under the proposed clearing house plan each road will only have to send statements regarding car hire to the clearing house, and the settlements will be effected by the clearing house. Car repair bills will be handled in much the same way, though it is probable that some preliminary correspondence in certain cases may have to be carried on either directly or through the clearing house before the account "presented" has been "allowed."

The clearing house as a means of adjusting charges between railway companies has been in successful operation for many years in Great Britain, though they do not have the car interchange and mutual repair system which is in vogue in this country.

The economy which the clearing house system introduces in the reduction of clerical work and the minimum transference of money or checks, is very large, because before payment takes place the accounts of any two companies can be compared and the charges of one offset by the charges of the other with the consequent transfer of balances only, which is in strict accord with the correct rules of banking.

The various economies which the clearing house can bring about may be likened to the economy of heating a number of flats in an apartment house by the operation of one heating plant in the basement, while the present system may be likened to the endeavor of the tenant families to keep warm, each with a separate fire in stove or grate. The clearing house idea is "community of interest" in the right sense of the expression.

About 500 miles of railroad are now in operation in Japan, and of this 35 per cent. is operated by the government, while all of it is more or less under government regulation, a special department of the government being maintained for that purpose. The roads in Japan are all narrow gauge, the standard there being three feet. The building of locomotives has only been attempted in the country in a very small way, but all of the cars, both freight and passenger, are built in their own shops, some parts, such as wheels, being imported.



NORTH COAST LIMITED ON THE NORTHERN PACIFIC, NEAR PORTLAND, ORE., BESIDE THE WILLAMETTE RIVER. SPEED, 45 MILES PER HOUR.

when it came to a traffic consisting of 100 ton electric engines and 80 ton Pullman sleepers.

The problem before Mr. Jacobs, Mr. Baldwin explained, was to make a support for the tubes when the bed rock of the river was from 100 to 150 ft. below the water. He solved the matter with the screw piles. These piles will be driven by means of a steel hydraulic screwdriver of terrific power, which will seize the pile at the top and twist and grind and force it down through the silt until the bottom of it reaches bed rock.

These piers are built upon from the top as they are forced down and are iron tubes 2 ft. and 8 ins. in diameter, except at the screw end, which is of steel, and for a number of feet from the bottom, has a diameter of 4 ft. 8 ins. with screw flanges nearly a foot in

vation in the tunnels and station area will be more than 2,000,000 cubic yards.

A Railroad Clearing House.

A very important question will come up for discussion at the April meeting of the American Railway Association. The question is concerning the establishing of a clearing house for the expeditious adjustment of car service accounts between railways.

The present way the work is done is for each railway to make bills against the other roads for repairs to cars and for car rental, under the per diem system, and these bills are copied as many times as either of the roads think fit. Vouchers are made out by the road which has to pay the bills, and a settlement is thus effected. The mileage accounts of the 436 private line companies have all to be settled in the same

General Correspondence.

A Few of the Mistakes We Have Made.

The mission of the press is to educate and while writing plain facts as they see them, they often make enemies. The railway journal should not swerve from the path of duty, even tho' they lose subscribers and circulation is lessened. A few years ago the one scoop idea was prevalent among railway officials and you, Mr. Editor, espoused its cause and gave it your full endorsement without thought of the after effect. That your contention was right on some cases and wrong in others, stands unquestioned. Changed conditions and the rapid growth from the little 8 wheels of a few years ago to the full grown "battleship" with its mile of cars of to-day has relegated that theory to the rear and makes it one scoop of almost continuous firing. That you lost subscribers among the firemen and engineers is true and that after you gave the matter fuller investigation and more serious consideration, you were manly enough to admit that it was not altogether a success, is equally true.

This brings to my mind one of Skee- yer's stories of the Irish fireman that always had plenty steam, but more black smoke than the superintendent thought necessary. One day his car was on the train and he went to the engine to instruct the fireman how to fire without smoke and took the scoop and stalled on first grade for want of steam. Handing the scoop back to the fireman he said: "You had better try her." Pat, looking from the superintendent to the steam gauge, asked: "Do ye want me to fire for sthream or for shmoke?" The fact that there was plenty of steam after that enables us to conjecture the reply.

I do not want you to think that I am trying to reopen the pages of LOCOMOTIVE ENGINEERING to this forgotten theory; I am referring to it to show how hard it is to eradicate a prejudice when once imbedded in one's mind. There is not a subscriber to your journal here in Dalhart prejudiced against the above theory and its endorsement by you seems to have been the cause. It is also a well known fact that a fireman likes to see the lever near the center of quadrant that you advocated the lever "on the center and the throttle in the tank" idea as earnestly as the one scoop can be proved from your editorials. Did the firemen rally to your support? No! they could not forgive your former theory. If your first contention was bad from the fireman's point of view, the

last was equally bad from the engineer's standpoint, and decidedly not the best or most economical way to run an engine—a fact that your research soon proved. And again, you admitted in a manly way—this should have brought back your lost subscribers. RAILWAY AND LOCOMOTIVE ENGINEERING is an educator and should be in the hands of every engineer. I am citing these few cases as they were given me as a reason why there are no subscribers here. I hope to see the prejudice overcome and soon a good package come every month. We should take the bitter things of life

the boiler head, in order to render the tallow cups readily accessible, it being before the time of automatic lubricators.

The object desired to be accomplished in designing this stand was to reduce the number of openings in the boiler inside of the cab to one, and to protect that one against the escape of steam as much as possible. This was accomplished by using a heavy flange base to stand, secured to boiler by four studs, the connection of the stand to this flange being weakened by a groove, so that in case of a collision or other

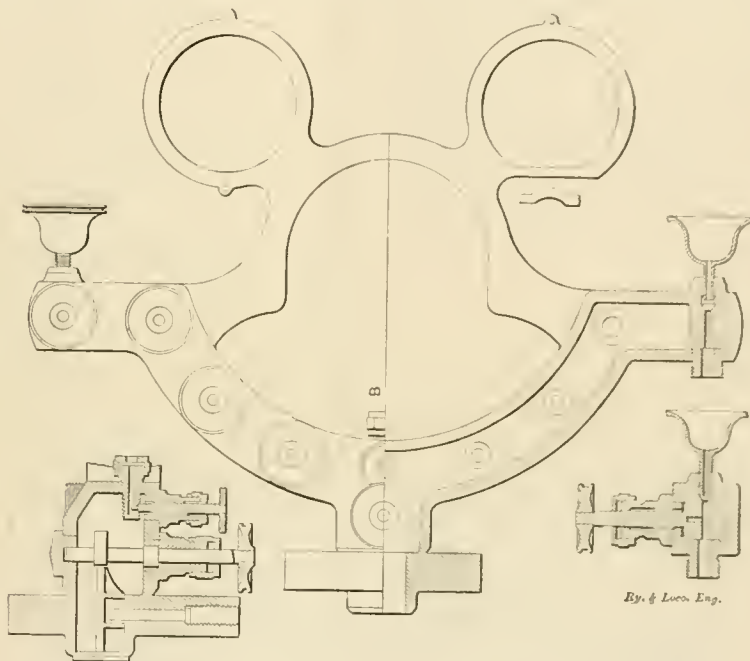

BOILER HEAD STAND.

without a murmur that we may better appreciate the sweets. J. McD.

Dalhart, Texas.

The First Boiler Head Gauge Stand.

Referring to the communication on page 67, of your February number, from Mr. H. F. Colvin, in reference to the standard steam gauge stand as designed by Mr. Johann, and used by him on the Wabash Railway as early as 1877, and in which communication Mr. Colvin refers to me for corroboration.

If it may be of interest, I send you herewith a blue print of the gauge stand so used, arranged for use on 17x24 in. engines, having straight top boilers.

For engines having wagon top boilers, a similar device in every respect was used, with the exception that the steam "horns" arched downward instead of upward, following the circle of

cause disturbing the cab, the stand would break off at this groove, allowing the safety valve, which seated on the flange connection on boiler side, to close and shut off the escape of steam.

In service this safety valve was held open by a cam spindle, which was operated from the stand on the outside, which also rendered it convenient in case it became necessary to adjust any of the connections, or grind in any of the various valves connected to stand, as it could be readily closed, and the work done quickly and conveniently with the engine under steam.

We had several demonstrations of the efficacy of this device in cases where the cab was torn off, tearing the stand from the base flange, and allowing the safety valve to close, positively shutting off any dangerous escape of steam.

For obvious reasons, the first stand had been in service but a few days before it had been christened "Soda Fountain" by the enginemen.

I do not believe that Mr. Johann claims absolute originality as to the utilization of one opening in boiler for two or more steam connections, as such an arrangement had been in more or less modified use many years before. The idea, however, of taking all steam connections from one opening, in conjunction with protecting that opening by an internal seated safety valve, to prevent escape of steam, in cases of breakage brought about by accident, I do think he considers as original with him.

Incidentally, the blue print sent you was made before either suitable blue print paper or the prepared paper became merchantable articles, and we were of necessity compelled to prepare our own paper. I also believe that the use of blue printing in a railroad shop was first utilized by Mr. Johann, while on the Wabash Railway, at Springfield, Ills., and I have a pleasant recollection that we "broke in" the draughtsmen from a large number of railroads who were sent to Springfield to learn the process.

GEO. D. BROOKE.

Minneapolis, Minn.

Reflects on the Link Motion.

On page 71, of your issue for February, there is an item reading as follows:

"Theoretical reasoning would teach and does teach that the distribution of steam in locomotive cylinders that most nearly approaches a hyperbolic expansion curve, as shown by the steam engine indicator diagram, represents the most economical use of the steam for production of work; yet no engineers ever saw a locomotive that produced indicator diagrams which approached in form diagrams taken from a good automatic engine, that was not wasteful with fuel. How this should be so is exceedingly difficult to understand, but we venture to assert that every engineer who has been accustomed to making tests of locomotives and has no reason to distort facts will agree with this conclusion."

Your comments as quoted above are erroneous and misleading.

In the first place you say, "Theoretical reasoning would teach and does teach that the distribution of steam in locomotive cylinders that most nearly approaches a hyperbolic expansion curve, as shown by the steam engine indicator diagram, represents the most economical use of steam for the production of work."

The error in this statement lies in its incompleteness. Under the Stephenson

link motion on a locomotive having cylinders 20x26 ins., cutting off at 6 ins. of stroke, the exhaust port will be opened under the influence of the Stephenson links when the piston has completed only about 16 ins. of stroke, and necessarily exhausts the steam from the cylinder at a relatively high pressure, whereas it is manifestly true and acknowledged by everybody who knows anything about the laws governing the use of steam, that if we could delay the opening of this exhaust port until the piston had reached, say, 21 ins. of its stroke, we would necessarily get more work out of the steam admitted to the cylinder, and would in the same proportion decrease the terminal pressure of exhaust.

In the locomotive with the Stephenson link motion cutting off at 6 ins. of stroke and exhausting at 16 ins. of stroke, you would find in case of a tight valve that the expansion line as between the 6 ins. of stroke and 16 ins. of stroke would approach very nearly "a hyperbolic expansion curve," and yet everybody knows that we have exhausted the steam from this cylinder at a relatively high terminal pressure, and, therefore, have not secured a high ratio of expansion. It is also true that under the Stephenson link motion cutting off at 6 ins. of stroke, that the exhaust port on the return stroke will close when the piston is within about 9 ins. from the end of the stroke, thereby entrapping in the cylinder a large volume of vapor and atmosphere, and necessarily absorbing an increased amount of power from the inertia of the moving train in compression. If, therefore, we could delay the closing of the exhaust port until the piston has reached, say, within 3 ins. of the end of its stroke, we would materially decrease the volume in compression, and would decrease the work of compression in the same ratio as the volumes are decreased, and, therefore, in that same ratio decrease the negative work, and, if therefore, able to delay both exhaust opening and exhaust closure until the piston has completed approximately 90 per cent. of its travel both forward and back, it is a self-evident proposition that you will do more work with the same quantity of steam admitted to the cylinder than is possible in an engine where only about 65 per cent. of either stroke is completed before release takes place on the one hand and exhaust closure takes place on the other hand.

With the delayed events as stated, you would find that the expansion line "approaches a hyperbolic curve," and in all probabilities this expansion line in the latter diagram will only be superior to the diagram in the former instance where release takes place at 16 ins. of stroke, because the latter re-

veals a greater ratio of expansion, but the first diagram may just as nearly approach a theoretical expansion curve as the latter, in that I have tested a large number of locomotive diagrams under both the conditions herein outlined, and have found frequently the expansion curve under the link motion to approach as closely the theoretical curve as I have ever found it in the case of any Corliss engine that I have ever tested, but you lose sight of the fundamental principle that governs the use of steam in the cylinder of an engine, and that is this, speaking generally: The ideal use of steam is had with the greatest ratio of mean effective pressure of the diagram to the terminal pressure of the diagram, and you will find by examining the two classes of diagrams from locomotives herein referred to, that in the one case at a 6 in. cut-off, in many instances, the terminal pressure is the same pounds per square inch as the mean effective pressure of the diagram; in other words, you are throwing away as much steam as you have utilized in work, whereas in the latter case, you will find that the mean effective pressure will frequently be more than twice the terminal pressure, and when you remember that the mean effective pressure is the measure of the work accomplished, and the terminal pressure is the cost of doing the work, it will not take you long to see that you are entirely wrong, as I have stated, in your statement which I have quoted in the opening of this communication.

In refutation of the statement that "no engineer ever saw a locomotive that produced indicator diagrams, which approached in form diagrams taken from a good automatic engine, that was not wasteful with fuel," I hand you herewith three indicator cards that are fair samples of diagrams taken from the locomotives I have referred to and which locomotives show a marked economy in the use of steam and fuel, and are acknowledged by all familiar with them, to be quick, reliable and to stay longer in service than any other engines of same dimensions in use on these lines.

There is no reason why we cannot have the correct use of steam in the engines of the locomotive just as well as we do in the engines of the best type in stationary practice, or in marine service. It is simply the intelligent application of the well known laws of steam that are familiar to every steam engineer, and are simple and can easily be learned by any man of ordinary intelligence.

In justifications of the statements I have made in regard to the performance of locomotives equipped with correct steam distribution, I have this morning

received report from one line which has these locomotives in daily use, stating that out of 110 engine failures in freight service during the month of January, these locomotives took no part and the party states also that at no time during the month were any loads or trains set out by these locomotives for any reason whatever, except to deliver freight at destination to which billed. A large percentage of the engine failures for January were due to "no steam," while the locomotives equipped with the correct steam distribution are recognized as the best steamers on the road, and for the simple reason that they do not use as much steam in doing a certain specific amount of work as is unavoidably required by the locomotives where the steam is exhausted and compression begins early in the stroke.

IRA C. HUBBELL.

Will Drivers Slip With Closed Throttle?

In the January issue of RAILWAY AND LOCOMOTIVE ENGINEERING appears an article on this subject and the writer of that article claims that an engine was badly damaged by such an occurrence. Sober thought tells us that it is an utter impossibility to produce increased motion after the force that produced this motion has been withdrawn. In designing locomotives it is customary and good practice to have the proportion of tractive effort to that of adhesion as 1 to 4, or greater. Since this tractive effort can only be secured by the admission of force (steam) to the cylinders of a locomotive operating against the pistons and they in turn transmitting this energy by means of connecting rods to the crank pins, producing motion or rotation of the driving wheels, how can it be possible to increase this exertion of the drivers after the steam pressure has been withdrawn?

The natural tendency of any rotating object is to begin its return to complete rest as soon as possible after the applied force has been withdrawn. If we can not, under normal conditions and with force applied slip the drivers, how can it be possible without this power to slip them, bend axles, rods or crank pins?

We must look to other causes for such dire results as the accident at Liberty. Catching the drivers on sand while they are slipping is one of them. In the February issue one correspondent suggests that the accident was due to overweight in the counterbalance, and another suggests that the engine was quartered wrong. These are suppositions merely with no proofs to base any facts on. It might be barely possible with an overbalanced driver, a well greased rail and

the momentum of the train, to produce such results, but with an engine quartered wrong, never.

Since this argument has been revived in RAILWAY AND LOCOMOTIVE ENGINEERING I have had an opportunity to visit a number of railway shops and get the opinions of able and experienced men on the subject. Through the courtesy of Mr. Geo. W. Smith, M.M. and Mr. G. J. Hatz, Gen. Foreman of the Illinois Central shops at Burnside, I got records of an engine worthy of consideration. This record appears on another page of this issue under the head of Correcting Errors in Counterbalance. The Illinois Central method of counterbalancing is ideal and the annexed form is the stand-

taken for slipping of the drivers was a chattering in the driving boxes and rods. When the wheels were dropped and weighed, the counterbalance was found perfect. Further investigation showed that at some previous time the engine had broken the wedge bolts, and the artist who put in new ones had substituted for the regulation taper head bolt—which gave freedom of movement to the wedge—a bolt with a straight head that caught on the pedestal and prevented free movement. No other work was done on the engine except putting in the proper taper head bolt, and since then the engine has been giving entire satisfaction and the trouble previously complained of has entirely disappeared.

JOS. A. BAKER.

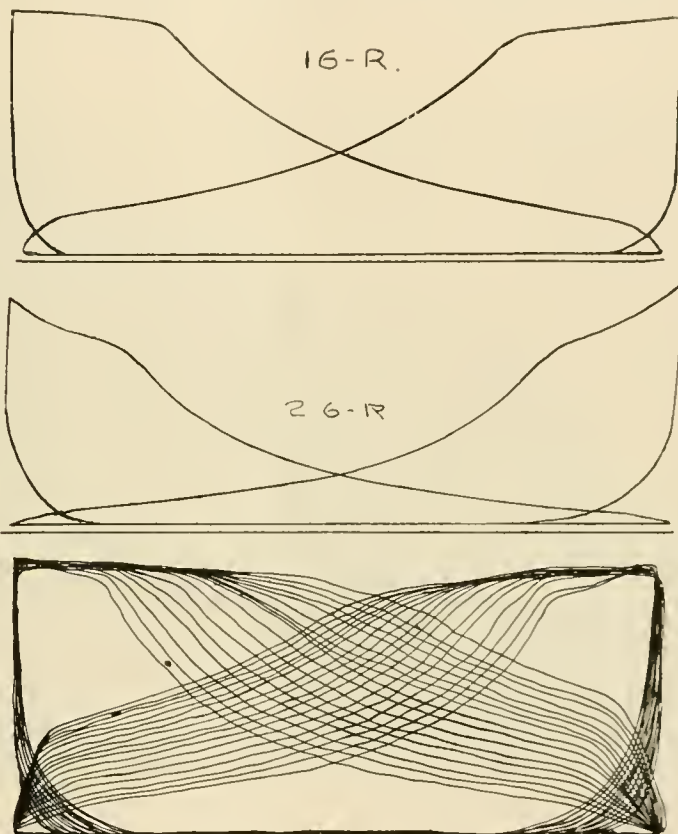

The above diagrams are all from an Allfree-Hubbell locomotive with cylinders 30x26, cylinder clearance 2.4%. All diagrams taken with No. 120 spring. Diameter of driving wheels over tires 61 ins.

Card 16 R was taken at 83 revolutions per minute, speed 15 miles per hour. Card 26 R was taken at 275 revolutions per minute, speed 50 miles per hour.

The continuous diagram without number was taken from same locomotive working from 4 ins. to 13 ins. cut-off to show relative uniformity of exhaust opening and exhaust closure regardless of point of cut-off, and to establish variable exhaust closure with point of cut-off.

ard used on all engines that enter these shops.

This form shows engine 901 badly overbalanced. No complaint of her slipping when shut off has ever been recorded against her. Engine 214 Baldwin build and counterbalanced perfectly was sent from a southern division to the Burnside shops on account of continuous complaint that she slipped when shut off and could only be quieted down by use of the air brake. Observations taken at the shop showed that what had been mis-

The Brotherhood of Locomotive Engineers have decided upon the beautiful city of Los Angeles, Cal., as the place where their next annual convention will be held. May 14 next is the date set for the meeting. It is expected that many of the engineers will have their families with them, as the trip to the convention city will be through the most picturesque portions of the country, crossing the Rockies and plains. Arrangements are being perfected for interesting side trips.

Engine Slipping When Shut Off.

The question has been asked me to make a reply as to engine slipping when shut off. Referring to page 67, of February issue of RAILWAY AND LOCOMOTIVE ENGINEERING. I find that in all cases this is due to a sprung axle, or engine being out of quarter, as you may call it, which, in most all cases, is caused by the use of only one sand pipe, allowing the opposite side to slip on the rail and spring the journal. Mr. C. J. Veig states that in two cases the engine had slipped so bad that it sprung the journal, but the reader will find that the engines had sprung journals, which caused them to slip in all cases. I should advise good sanders. Hoping this information will be of some benefit to the readers.

J. F. KURTH.

Jamestown, N. D.

Driving Axles Get Cracked in Wheel Lathe.

Having watched the game closely, it is the writer's opinion that broken driving axles get their initial fracture in the driving wheel lathe. Do you ask how, and why? Bad dogging in the lathe is the "how." Ignorance or indifference on the part of men who are paid to look after the work, is the "why." In the engraving is shown a pair of modern driving wheels hanging in the lathe centers. Wheels will always assume this position when first put in the lathe. The operator will put the lathe dog or driver in either of the openings, A, because it is easiest to do so. We will suppose he is working on the right wheel first. Dotted lines show left crank and counter balance. The lathe is now turned over until he can dog the left wheel at a point opposite the right dog, or where the right dog is up, the left dog is down. So far, so good; but he stops at one dog for each wheel, which is a mistake. Wheels should never be turned without two dogs for each wheel placed as nearly opposite as possible. Try to bore a hole with an auger, keeping one hand in your pocket; not much of a success, is it? Well, the principle applies to turning driving wheels with but one dog for each wheel. The tool, D, being the fulcrum, and the dog the power, between the points C and B, the dog is lifting the wheel in the line of the arrow E, while the opposite dog is forcing everything down. The deadly counterbalances, as they are brought in from the road, having lost none of their weight, are assisting in this up and down movement, hanging back on one part of the revolution, hanging down on the other, and aggravating the work of destruction caused by the one dog for each wheel. Watch the work when flanging tools are being used;

notice the action of the wheels; also listen to the fuss the gears are making. Is there not something radically wrong? The whole trouble is caused by trying to turn tires by using one dog for each wheel, and when done the wheels are not round.

On the face of all this there is the foreman posing as a wise man and who thinks he has everything down fine!

Another bad feature is in placing the dogs too close to the center. What is the condition of the lathe centers? Do they run true? You cannot bet on them, unless they are looked after. In speaking of lathe centers, it is a question that should be taken up by the M. M. and M. C. B. Associations, which should adopt some standard taper for all car, tender, engine truck and driving axle centers. Make them all one taper and of a generous depth. Sixty degrees is a good taper, but the lathe centers want to go well into the work.

Speaking of standards, a machine tool builder advocates standardizing all parts of lathes of certain size, while

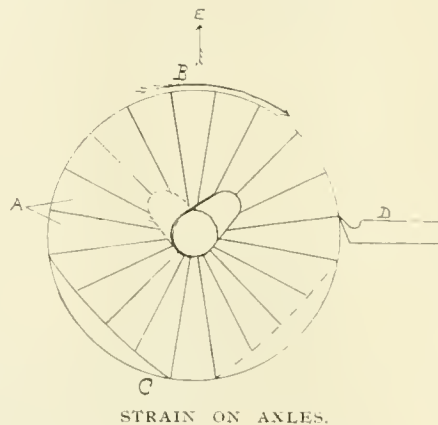

his own shop is putting 12 threads on $\frac{1}{2}$ inch bolts, but I am digressing. A good machinist or blacksmith, when he wants to strike ringing blows, reduces to his hammer handle between the grip and hammer as small a size as possible. The modern steel wheel center, with its long, slender spokes and heavy counterbalance at the end of them, is the locomotive's hammer that gets in its work in the wheel lathe.

The writer is working on the details of some new features in driving wheel practice, which, it is thought, will do away with some of the troubles mentioned above.

LEAKY FLUES.

Now comes the question of leaky flues and fire boxes, and of the means to cure them. My good brethren, why not try to prevent them? Is it not possible that these leaks are started right at the ash pit? Does it ever occur to you that the deadly blower in the hands of an irresponsible man is the cause of a great many of the ills that locomotive

boilers are heir to? An engine comes in with a heavy fire; she is run over the ash pit; the blower is put on, and while one man knocks out the fire, another is cleaning out the ash pan, and the blower is getting in its deadly work, and the "band plays on" until the victim is housed out in the snow or over a cold, damp pit in the round house. In either case the dampers are left open, giving a free circulation to the cold air through the flues. Is it any wonder they leak? On a road where the undersigned once had the sayso, our engines had to stand out of doors during their layover; there was trouble with leaks. Having some old tank iron on hand, I had smoke stack covers made and sent to each end of the road, and insisted on having the stacks covered and dampers and fire doors kept closed while the engines were not in use. The result was that leaks were reduced to the minimum and after twenty-four hours' standing the fire box was found quite warm. When a boiler is not to be washed out, keep it warm. General foreman, round house fireman and road foreman of engines should look after these little details if they individually care a hurrah about the engines.

In regard to broken stay bolts, if there was less brute force used in riveting up the ends, perhaps they would last longer. We cannot hammer the life out of a piece of metal when cold and then expect it to have any strength.

WHEELS SLIPPING WHEN RUNNING DOWN HILL.

It is known as a fact that the wheels are all of one size on those engines that slip while drifting down hill? Yes, I know, the weight is about the same on all four wheels, but the main wheels are heaviest on the rail. I do not understand your correspondent from Osawatomic, in saying the engine was quartered wrong. What was the trouble with the quartering? W. DE SANNO.

San Francisco, Cal.

Employees of the Delaware and Hudson and dependent members of their families will no longer be given passes over the road. They will be privileged to buy 500 mile tickets at \$2.50 each, but must have been in the company's employ ninety days before being entitled to this concession, and can buy only one ticket in thirty days. If an employee leaves the service the unused portion of his ticket will be redeemed at the rate of half a cent a mile. The tickets are not good on special or excursion trains. The practice of selling special tickets to railway employees is very common in Europe and is highly popular.

Elk Rock Trestle.

I send you a photo of Elk Rock and trestle. This scene is five miles south of Portland, Oregon, on the Willamette river. The trestle is 1,040 long and 50 ft. high; the rock is 400 ft. from the water to the highest point. This is a beautiful sight, and a fine piece of engineering.

F. S. CAAW.

Portland, Ore.

Capital or Lower Case Letter?

I notice that in giving the name of a railroad in RAILWAY AND LOCOMOTIVE ENGINEERING you nearly always use a capital for railroad or railway. This is not done by other railroad publications, which makes me believe that the editorial staff of your paper are weak on English grammar. There is a right way of doing things of that kind and I believe you are on the wrong side, since the most pretentious publications in the United States do not use a capital for railroad or railway. I am a warm admirer of RAILWAY AND LOCOMOTIVE ENGINEERING, which moves me to write this letter, for I believe the blunder is made through a misunderstanding.

RALPH WILMARD.

Philadelphia, Pa.

We do not make any blunder in the cases where we use a capital letter in writing railroad or railway. If the word is part of a corporate name of a company it is part of a proper name and, therefore, ought to have a capital letter. When we use the words railroad or railway in a general sense, the rule of the office is to use lower case letters. The people who use lower case letters in printing railroad in a corporate name commit a grammatical blunder, no matter who they may be. For instance, Erie Railroad and Great Northern Railway are correct. To use a lower case letter in these words, displays as much ignorance of the rules of grammar as the person who uses *i* as the first personal pronoun.—Ed.

Device to Help the Memory Concerning Meeting Points.

In years past the writer had considerable experience on single track railroads, and has seen some close calls caused by forgetting train orders; and he has long had in mind a plan which, if adopted, would always keep the next meeting point before the eyes of both engineers and not allow them to forget it. Your article in the issue of RAILWAY AND LOCOMOTIVE ENGINEERING for March, page 136, under heading, "Wanted—A Train Order Holder in the Cab," has awakened my interest in the matter, and here is the plan:

Have all engine cabs equipped with a lamp cage, made of tin, said cage to be suspended from roof of cab or from

any convenient place, in plain sight of engineer and fireman. The front side of cage to be fitted with a sliding section, or, I should say, a receptacle for same. In these sections should be cut the names of the stations on each division of the road, one name on each section. A sufficient number should be made so that each station where there is an operator could be supplied with sections containing the names of all other stations on the road or division.

These sections are to be fitted with red glass, back of names cut in same. Now, when engineer of, say, train No. 7, stops at Streeter and receives orders to meet and pass No. 8 at Clinton, operator at Streeter would give him a section containing the name "Clinton." The engineer of No. 7 would compare same with written order, and

Designing of Locomotive Boilers.

BY ROGER ATKINSON.

Before entering into the details of boiler design it is advisable to give some consideration to the general principles which pertain to the subject. The object to be attained is the conversion of water into steam at a rapid rate, since the total weight of boiler and water which can be carried is very limited compared with the horse power to be developed. This object, namely, to obtain the greatest horse power from the least possible weight of boiler and water has been the principal reason why locomotive boiler designers have hitherto led the way in the adoption of higher pressures, until recent years when other branches of engineering, such as torpedo boat builders, etc., have found it



ELK ROCK TRESTLE, NEAR PORTLAND, ORE.

if both say "Clinton," he can put written order in his pocket, if he wishes to, but takes his section into the cab and slides it into the lamp cage, and goes ahead. Now, with a bright light back of the red letters in the section he and his fireman will always have the next meeting point staring them in the face, and it is not likely that they would forget. When No. 7 is held up for orders again, engineer would take section from cage and leave it with operator to be replaced with one for next meeting point. Each section could be stamped with the name of issuing office, and returned to the proper places by local trains every day, thus insuring a sufficient supply for each station.

E. C. ALLEN.

Richmond Furnace, Mass.

necessary to proceed upon similar lines to go to even greater lengths.

In designing a locomotive boiler the first part of the subject to be considered is the kind of fuel which is to be used. This naturally divides itself into three sections, viz.: the consideration of wood, coal, and oil. The use of wood for fuel has almost disappeared on railways, and in those cases where it is still used, the boilers are generally designed with a view to the eventual use of soft coal. The only characteristic of the fire box designed for wood burning is that it is usually small as to grate area and large in capacity, with the fire hole rather high and near the top, to enable the fireman to fill the fire box entirely with wood and keep it in that condition as far as possible while in ser-

vice. In order to adapt such a fire box to burn soft coal, it is advisable generally to lower the fire door one foot or more, according to depth of box, which enables the fireman to distribute the coal to better advantage over the grate, and attend to the condition of the fire generally, and this alteration also prevents cold air entering the open door from striking directly on the crown sheet.

When designing a boiler for the use of coal we have to divide the subject into two sub-heads: anthracite or hard coal, and bituminous, or soft coal, and all the various grades and qualities of these have to be considered in assigning the various proportions of grate surface and heating surface, etc. The principal reasons for this are: (1) The different rate at which these fuels burn, and (2) the amount of hydrocarbon gas evolved or produced in the process of combustion.

The eminent engineer, Dr. Siemens, commented upon the locomotive fire box as being a very bad example of designing. His remarks were to the effect that, first, the fire box is designed to burn fuel in; that is, to maintain and facilitate combustion of the fuel, and second, it is surrounded by a water casing with the apparent object of cooling off the fire and flame, and there is much truth in his comment.

Referring to the rate of burning we know that soft or bituminous coal burns quickly and gives off much hydrocarbon gas by distillation, all of which must be burned, if possible, and as this gas, together with the necessary air for its combustion, requires a large space in which to mix thoroughly, we have to give the fire box considerable volume. If this is not done, the comparatively cool surface of the fire box sheets chills these gases below the point of ignition and they pass off unconsumed as carbon or smoke, and as partially burned carbon in the form of carbonic oxide gas, in the latter case about two-thirds of the heat value being lost.

In a similar manner, if the flues are small in diameter, any flame which enters is soon extinguished by the comparatively cold flue and unless the flue is very short, a loss of combustion is entailed. It is, therefore, plain that the longer the flues are (from considerations of design) the larger their diameter should be, to avoid extinguishing the flame. On the other hand, if the flues are too large for their length there will be a loss of heat due to sufficient time and surface not being provided to absorb as much heat as possible. In this case the smoke box temperature would be unduly high owing to waste heat, and it is generally considered advisable to so proportion the size and length of the flues that the

smoke box temperature will not be over about 800° F. In order to attain such a result, flues which have a length of 10 ft. or less are frequently made 1½ to 1¾ ins. diameter; from 10 to 12 ft. long. 1¾ to 2 ins. diameter; over 12 ft. and up to 14 ft., 2 ins. diameter; above 14 ft., 2¼ ins. diameter. However, the present tendency of designers is to use 2 in. flues even up to 20 ft. long.

In considering the use of anthracite or hard coal we know that it burns slowly, and, therefore, in order to provide for the combustion of an amount sufficient to produce a given horse power in a limited time, a large grate surface must be provided, since the depth of the fire cannot be increased above a certain limit which is found best for the air supply. Thus it is common practice to make such a grate surface as large as 80 sq. ft., especially for culm burning, or for any size up to pea coal. Where larger sizes of this fuel are used, the grate area may be diminished, as the fire may be made deeper, since the larger blocks of coal permit a freer access of air. Next, as there is but little flame produced from the combustion of anthracite, the volume of the fire box need not be large, and it is better to have the crown sheet rather close to the grate. For the same reason the flues are usually not made more than 1½ to 1¾ ins. diameter, depending upon the length, as there is little or no flame to extinguish by the chilling action of the flue. Flues of 1½ ins. in diameter are usually adopted up to about 12 ft. long and 1¾ ins. diameter from 12 to 15 ft. long.

The use of bituminous coal in fire boxes with large grate areas, such as those designed for anthracite culm, is sometimes practiced under special conditions but it is not economical from a common standpoint, as it has been shown by careful experiment that excessively large grate areas are wasteful. For inferior kinds of soft coal which cannot be made to produce sufficient steam on a grate of ordinary proportions, it is usual to design special types of fire box such as those which rest on the top of the frames, with area about 30 to 35 sq. ft., and when the engine is large, it necessitates the fire box being still further widened as in the "half wide" type, with an area of 50 to 65 sq. ft.

From the foregoing remarks the object of the brick arch, which is sometimes used, is obvious, viz.: It causes the mixture of hydrocarbon gas from soft coal and the air drawn through the fire to mingle more perfectly, to take a longer course before reaching the flues, and on account of its capacity for absorbing heat, it facilitates the combustion of the gas and smoke by its high temperature. In this connection

it may be said that various attempts have been made to construct locomotive fire boxes of fire brick or lined with fire brick to facilitate the combustion of the coal gas, but practical difficulties in maintenance have been found too great to permit of its being used. This brings us to the consideration of oil as fuel. The oil is usually thrown into the fire box in the form of spray, by means of one or more steam jets, which are either inserted through the back of the fire box, or under the back of the mud ring: the spray is thrown against the back of a brick chamber built inside the fire box which thus protects the plates and by the heat which it attains assists the combustion of the oil, the flames rising into the upper part of the fire box in the same manner as in the case of the ordinary brick arch. The construction of the fire box for the use of oil does not, therefore, differ materially from the fire box of a soft coal burning engine and, in fact, most of the oil burning locomotives are simply converted coal burners.

(To be continued.)

German Spark Arrester.

An ingenious locomotive spark arrester has been devised by a German engineer named Heydemann which has been successfully used on the Mecklenburg State Railways for the past two years. It consists of a series of three rows of bars, each about 2 ins. wide by 1/16 of an inch thick, set so that the edge of each only is opposed to the draught. The bars are set in a frame made to fit the smoke box and the bars, though held securely, are yet free to expand or contract with changing temperatures.

The arrangement of the bars is in three rows and the position of each may be more clearly indicated by considering for a moment what might be done with a single file of soldiers. Suppose the soldiers to stand side by side without a rear rank. To arrange them as the bars of the smoke arrester are arranged it would only be necessary to make Private No. 1, on the left of the rank stand where he was, No. 2 would step back one pace, No. 3 would stay where he was, No. 4 would step forward one pace, and No. 5 would stay where he was, and so on all down the line. In this new arrangement all the odd numbers would be in the center row and privates 2, 6, 10, 14, etc., would be in the back row and privates 4, 8, 12, 16, etc., would be in the front row.

Applying this to the spark arrester bars it will be seen that there are twice as many bars in the center row as there are in either of the others. As the back edge of front row slightly overlaps the line of the front edge of the second row and the back edges of second in like manner slightly overlaps the front of the

back row, it is evident that the space between the rear edge of any bar and the front edge of the row behind is the space through which any spark must pass. This space is the $\frac{1}{8}$ of an inch, and the sparks are, therefore, reduced to that size in order to pass through. The arrangement, however, allows the freest passage for the smoke box gases to pass through.

New Freight Engines on the Erie.

The Erie Railroad, of which Mr. W. S. Morris is superintendent of motive power, have lately been extensively increasing and renewing their power equipment, and the 2-8-0 engine shown in our illustration is from the Schenectady shops of the American Locomotive Company.

The engine is simple, with 22x32 in. cylinders, and the driving wheels are 62 ins. in diameter. The weight carried on the drivers is 179,000 lbs. and the

carried between the top and bottom bars of the frame. A couple of coil springs fore and aft in suitable cases on each side complete the spring gear for these wheels.

The boiler is a straight top one, 74 $\frac{3}{4}$ ins. in diameter in the first ring. The total heating surface is 3,230.8 sq. ft., divided between tubes and fire box, there being 3,065.7 sq. ft. in the former and 165.1 in the latter. The grate area is 54.4 sq. ft. The crown and roof sheets are level, with about 22 ins. of space between them. The back sheet slopes about 20 ins. from the perpendicular. The horizontal seams are butt joint, sextuple riveted.

The tender is of the usual style, with water bottom tank, capable of holding 7,000 U. S. gallons of water and 12 tons of coal. The frame is made of 10 in. steel channels and the trucks are diamond pattern, of the Barber type. A few of the principal dimensions are as follows:

road companies. Mr. Thorn, director of purchases for the Harriman lines, announces that the equipment of the entire Harriman system will be standardized. When the plan has been carried into effect it will be possible to duplicate any piece of rolling stock at any shop of the system. The work of bringing the equipment to a uniform style will be worked out gradually as new stock and repairs are required. The plan of standardizing will include the Union Pacific, Southern Pacific, Oregon Short Line, Oregon Railway and Navigation Company, Illinois Central and Chicago and Alton. The officials belonging to the Spencer lines, which include the Southern Railway, the Cincinnati, New Orleans & Texas Pacific and other southern lines, are working a system of standards to make the rolling stock of all the properties as nearly uniform as possible.

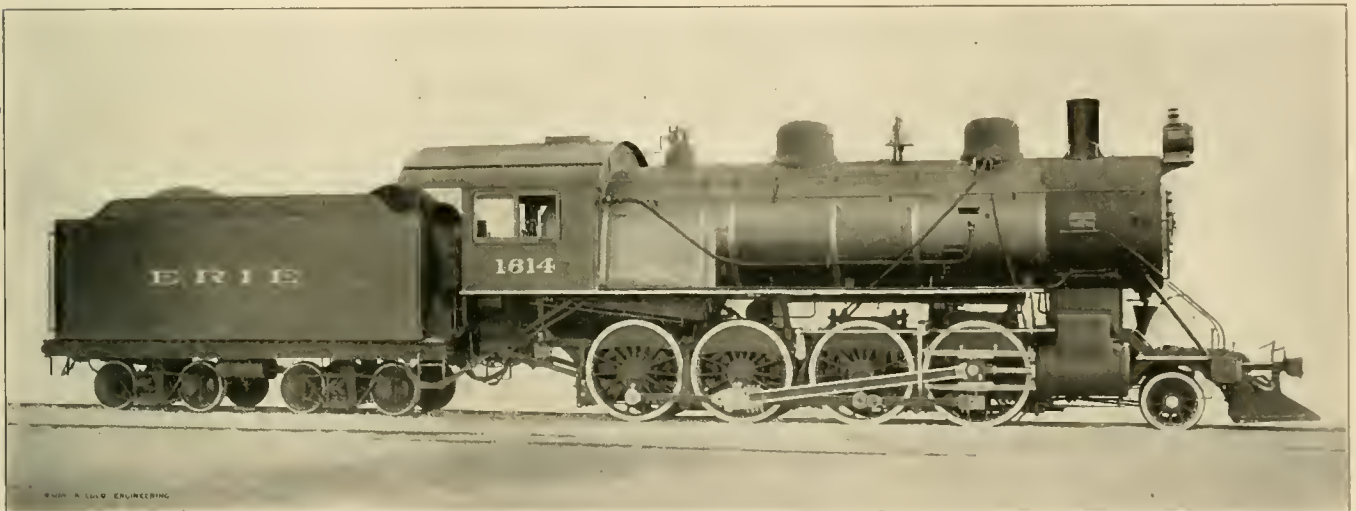

HEAVY CONSOLIDATION FOR THE ERIE RAILROAD.

total weight of the whole machine is 202,000 lbs., thus leaving about 23,000 lbs. on the pony truck in front. The valves are the Richardson balanced type. They are set line and line in full forward gear, and have $\frac{1}{4}$ in. lead at 8 in. cut-off. The main drivers are the third pair. The eccentrics are carried on this axle and the radius of the expansion link is 50 ins. The valve motion is indirect, and as the link is placed forward of the rocker, the transmission bar runs from the link block back to the lower rocker arm pin.

The spring gear of this engine is arranged so that the pony truck and the two leading pairs of drivers are equalized together, and these driving springs are overhung. The second pair of drivers are the only wheels under the engine which are not flanged. The equalization of the two rear pairs of drivers is accomplished by a spring placed between them on each side and

General Dimensions—Weight engine and tender in working order, 331,100 lbs.; wheel base, driving, 17 ft. 0 in.; wheel base, total, 25 ft. 11 ins.; wheel base, total, engine and tender, 56 ft. 0 in.

Cylinders—Size of steam ports, 19x1 $\frac{3}{4}$ ins.; size of exhaust ports, 19x3 ins.; size of bridges, 1 $\frac{1}{2}$ ins.

Valves—Greatest travel of slide valves, 6 ins.; outside lap of slide valves, $\frac{3}{8}$ in.

Wheels, etc.—Dia. of driving wheels outside of tire, 6 ins.; dia. and length of driving journals, 9x9 $\frac{1}{2}$ ins. dia. x 12 ins.; engine truck journals, 6 ins. dia. x 10 ins.; dia. of engine truck wheels, 33 ins.

Boiler—Working pressure, 200 lbs.; thickness of plates in barrel and outside of fire box, $\frac{11}{16}$, $\frac{3}{8}$, 1, $\frac{3}{4}$ and $\frac{5}{8}$ ins.; fire box, length, 104 $\frac{1}{2}$ ins.; fire box, width, 75 $\frac{1}{4}$ ins.; fire box, depth, front, 71 $\frac{1}{2}$ ins.; back, 57 $\frac{1}{2}$ ins.; fire box plates, thickness, sides, $\frac{3}{8}$ in.; back, $\frac{3}{8}$ in.; crown, $\frac{3}{8}$ in.; tube sheet, $\frac{1}{2}$ in.; fire box, water space, 3 & 7 ins., front; 4 & 5 $\frac{1}{2}$ ins., sides; 4 & 5 ins., back; tubes, number, 372; dia., 2 ins.; length over tube sheets, 15 ft. 10 ins.

Tender—Weight, empty, 46,800 lbs.; journals, dia. and length, 5 ins.; dia. x 9 ins.; wheel base, 16 ft. 8 ins.

Standardizing of railway machinery is about to be carried out systematically by the principal combination of rail-

The International Association of Machinists, Keystone Lodge No. 226, at Sayer, Pa., which is composed of Lehigh Valley Railroad shop men, has an educational feature at its lodge meetings that is worthy of imitation all over the country. The feature is only a modest question box in which queries of various kinds are placed by any number of enquiring mind. The questions are concerning general mechanics, steam engines, locomotives and boilers, and the questions are forthwith discussed at the next meeting. The action of the members in discussing live questions concerning their employment shows that they all take an intelligent interest in their work. Boswell, in his life of Johnson, says: "Knowledge is of two kinds, we know a subject ourselves, or we know where we can find information upon it." We think the question box applies very well to the latter part of this quotation.

Railway and Locomotive Engineering

A Practical Journal of Railway Motive Power and Rolling Stock.

Published Monthly by

ANGUS SINCLAIR CO.,

174 Broadway, New York.

Telephone, 984 Cortlandt.

Cable Address, "Loceng," N. Y.
Glasgow, "Locanto."

Business Department:

ANGUS SINCLAIR, President.
FRED M. NELLIS, Vice-President.
JAMES R. PATERSON, Sec'y and Treas.

Editorial Department:

ANGUS SINCLAIR, Editor.
F. M. NELLIS,
GEO. S. HODGINS, } Associate Editors.
JOS. A. BAKER,

Advertising Department:

Eastern Representative, S. I. CARPENTER, 170 Summer St., Boston, Mass.
Western Representative, C. J. LUCK, 1204 Monadnock Block, Chicago, Ill.

British Representative:

THE LOCOMOTIVE PUBLISHING CO., Ltd., Amen Corner, Paternoster Row, E. C., London.

Glasgow Representative:

A. F. SINCLAIR, 7 Walmer Terrace, Ibrox, Glasgow.

SUBSCRIPTION PRICE.

\$2.00 per year, \$1.00 for six months, postage paid to the United States, Canada and Mexico. For other parts of the world, \$2.50 or ten shillings. Single copies, 20 cents. Remit by Express Money Order, Draft, Post Office Order or Registered Letter. Mailing address can be changed as often as necessary—always give old and new address, and if you subscribed in a club, state who got it up. Please give prompt notice when your paper fails to reach you properly.

Entered at Post Office, New York, as Second-class mail matter.

Copyright by Angus Sinclair Co., 1904.

For Sale by Newsdealers Everywhere.

Stopping With Engine Reversed and Air Brakes Applied vs. Stopping With Air Brakes Alone.

A correspondent writes: "Can a train of seven cars, tender and locomotive be stopped quicker by applying the air brakes and reversing the engine than it can if the air brakes are applied alone?"

This question has been asked several times during the past few years, and each time we have replied to it through the columns of this paper, believing it advisable to make numerous replies, in order that this important matter might become generally understood. We believe that our efforts have been largely successful, especially in the direction of enlightening railroad people, and partly so with respect to the legal fraternity which occasionally seeks information along these lines. A case has recently come up in court in the state of Georgia, in which the railroad company has been defeated in a suit for the killing of a hog by a passenger train, on the grounds that the engineer did not reverse the engine, as this failure to reverse is in direct contradiction to the requirement of the statute which reads that railroads shall, in such cases, "use all means known to

a skilful engineer" to stop the train quickly.

In view of the fact that this statute is very old and was doubtless enacted before a brake was ever placed on the driving wheels of the locomotive, it would seem that a discussion of the question would be unnecessary, and that the court certainly appears in error in deciding against the railroad company. Various methods of railroad operation have greatly improved in the past few years, and train braking has likewise kept pace, and even managed to creep a little ahead of some other departments in railroad service. Many years ago when air brakes were applied to the train alone, and through prejudice or for other reasons, brakes were not applied to the driving wheels of the locomotive, it was the prevailing practice, founded on good reasons and practical experience peculiar to that period, to reverse the locomotive after the train brakes had been applied in order to make the shortest possible stop. Since the introduction of air brakes to the driving wheels of the locomotive, thus putting the entire train and engine brakes under the engineer's single operating brake valve handle, however, it has been found that quicker stops may be made with the air brakes alone; and, in fact, if the engine be reversed after the driving brakes have been applied, locking of the driving wheels will result in their skidding and in a loss of braking power, which would otherwise be retained and be available were the air brakes not thus interfered with and their action thus impaired.

As far back as the Westinghouse-Galton brake tests in England, it has been known that the greatest retarding power to a revolving wheel under a car or locomotive of the train, is obtained by applying as much pressure to the wheel, through the medium of the brake shoe, such as will all but stop the rotation of the wheel. The period of "impending slip," in which the braking power is limited to "almost slipping," is the highest value which can be obtained with the brake. After rotation is stopped and skidding begins, the retarding power is correspondingly reduced and lost.

Several years ago, in order to acquire some absolutely reliable data on this matter, Mr. J. W. Thomas, Jr., general manager of the Nashville, Chattanooga & St. Louis Railway at Nashville, Tenn., in coöperation with a committee appointed by the Air Brake Association, made a series of tests to determine whether the highest efficiency in train braking could be accomplished by applying the train brakes and reversing the locomotive, or by the use of the train brakes alone, brakes being applied to the driving wheels and forward truck of the locomotive. The result of these

tests, which were carried on for over a week and extended through more than one hundred runs, was that it was found that the advantage lay decidedly with the application of the train brakes alone. These practical tests have been widely accepted by railroad people and by legal authorities.

The successful effort to secure the highest efficiency in train braking, is not confined alone to the effective work of the brakes after that work is once begun, but is largely increased by the quickness with which the brakes are put into effective operation. The old method of a separate brake valve handle for the driver brake, another handle for the train brakes, and the reverse lever to be used if deemed necessary, resulted in a great loss of time in getting the brakes down to business. In some of the tests made, from two to three seconds time was consumed from the beginning of the setting the brakes to the finishing up of the same. Under these circumstances if a train was running 70 miles per hour, which is not an uncommon speed for today, and at which speed the train is covering the ground at the rate of over 100 ft. per second, the time of the stop will be very much lengthened if two or three seconds is required in which to put all of the mechanism into operation. In a stop recently made in a brake test, a train was running 70 miles an hour, and was stopped in 1.425 ft. Such a loss of time as three seconds in the operation of setting the brakes as above indicated, would have permitted the train to run nearly 300 ft. further. When the train should have been brought to a standstill, it would have been actually running at a speed of 35 miles per hour, containing much energy to do damage in event of a collision.

In view of the foregoing, and of the very practical tests conducted by Mr. Thomas and the Air Brake Association, it would seem that there should be no further doubt as to the advisability of applying the train brakes which are continuous throughout as a preferential practice to the old method of reversing the engine.

The Winter Crop of Engine Failures.

To the average traveler there appears no reason why railroads should not be able to land him at his destination on time as well in January as in July, or why engine failures should be more numerous in winter than in summer.

The railroad companies have brought this unreasoning censure on themselves. In order to divert travel to its own line, each company has added comforts and conveniences until now the public demands as necessities of travel what were a few years ago unheard of luxuries. At the same time the railroads have tried to maintain

summer schedules during one of the hardest winters the country has ever known. Comfortable coaches have given way to luxurious palace cars with all modern conveniences of hot water, steam heat and baths, while the cost to the traveler has remained the same. An unusual drain is put on the locomotive in order to supply the steam which makes these conveniences possible.

Few travelers realize that with zero weather the locomotive is at its greatest disadvantage. Trains pull harder; frosted rails which destroy adhesion cause the engine to slip badly. Foggy weather also makes fast time impossible. Real estate, sometimes called coal, which burns fairly well in good weather, but which has a large percentage of snow and ice mixed with it in winter, furnishes the firemen with poor material for keeping up a fire to supply the steam necessary for moving the train, warming coaches, heating water, etc., for the grumbling traveler who pays for one seat and occupies four.

Nor is this all the trouble. The transportation department which insisted on the mechanical department installing steam heat in the coaches, fails to instruct the train crews in the proper operation of these appliances. From personal observation one line was found heating its cars and maintaining a temperature of 70° with a 40 lb. steam pressure and keeping its trains nearly on time, while another line was using an 80 lb. pressure and giving a 50° temperature. On the latter line steam traps, valves and hose couplings leaked badly and allowed pressure to escape, and in addition to this, the train crews delighted in throwing open the doors the moment the engineer whistled for a station, transforming the coaches into refrigerators. On still another line, one proverbially late, the condensation from the valves and piston glands was sufficient to cover the entire train of eight cars with a coating of frost. This meant a loss of time due to the loss of power escaping by these avenues, coupled with the heavy drain on the boiler to maintain steam heat in the coaches with poor hose connections.

This overtaxing of the boiler is a prolific source of engine failures in winter. Carelessness on the part of those whose duty it is to know that more time is needed for inspection is another cause of delayed trains. Slower schedules which can be maintained in winter season are a necessity. Crews must be carefully trained in the manipulation of new appliances in order to make these successful. The "man higher up," who goes over the road in a luxuriously furnished private car supplied with various gauges and speed re-

orders to secure data of the trip, might learn something worth knowing if he would occasionally ride in the cab with the engine crew during a "cold snap" and see and feel the disadvantages under which the most loyal branch of the railway service does its work in winter. It would also convey needed experience if he would ride at irregular intervals in the day coaches, where he could note the vagaries of trainmen in refrigerating the temperature through carelessly leaving doors and ventilators open.

Truth is Better Than Comfortable Error.

The poet, Cowper, tells us that "He is a freeman whom the truth makes free, and all are slaves beside." With this as a text, we would like to say a few words concerning a species of special pleading, as lawyers would call it, which we have recently seen in regard to the railway accident statistics of this country and of Great Britain. We call it special pleading because it appears to be an effort to prove a special case by finding an argument which apparently fits, while ignoring the broader considerations which should have weight in a general conclusion.

It has been conceded, and facts and figures bear out the assertion, that fewer people are annually killed or injured on British railways than are killed or injured on railways here. That is the fact at present and it is the part of candor and honesty to admit it frankly, because it is only by the realization of this truth that we can hope to make progress in the direction which all desire. That we are making progress, no careful observer can doubt.

Mr. Slason Thompson, of Chicago, who has recently published a very interesting pamphlet on Railway Accidents in the United States and Europe, has adopted a method of reasoning which we do not think helps to a right understanding of the matter. His argument has been taken up by a western contemporary and, although logically elaborated, the unreliability of the assumption made in the calculation appears to us to destroy the correctness of the inferences drawn. The solid railway mileage of this country has been introduced into the calculation, and all previous deductions on the subject have apparently been upset.

The mileage idea as worked out by our friends in the West is briefly this: In 1902-3, for instance, the balance for safe railway travel was in favor of Great Britain. The railways of the United Kingdom carried more people than our railways carried in the same time. Where 100 persons traveled here, 181 traveled there. In all kinds of railway accidents on railways, Great Brit-

ain killed 1,171 persons and injured 17,814. The railways of the United States killed 8,588 persons and injured 64,662 in the same time. These are the plain figures taken from Whitaker's Almanac (English) and from the New York *World's Almanac*, both for the current year. When the mileage idea is introduced the whole look of the thing can be changed in the twinkling of an eye.

The United States has about 9 $\frac{1}{10}$ times as much mileage as that of England, Ireland and Scotland put together. Now, if on their comparatively small mileage they kill 1,171 persons in a certain year, what would they do if they had our mileage? The answer given is that they ought to kill 9 $\frac{1}{10}$ times more people than they have killed. Therefore, $1,171 \times 9.1 = 10,656$ persons killed "on the mileage basis," while we killed only 8,588 persons. Our railways actually killed more than 7 times the correct British figure, but our mileage is over 9 times greater than theirs and our train operation therefore appears so much safer "on the mileage basis," that unless we kill something over 9 persons to their one, we come out ahead.

To push this process of reasoning, one step further without doing it any violence; just imagine a coral island in the South Pacific Ocean having a railway 2 miles long. Further, imagine that only one train was run during the entire year and that on this solitary occasion two persons had been killed. The proposition problem used by our friends stands as before, because it takes no account of the relative number of people carried in the countries compared. The question in proportion is, therefore, if the Coral Island Railway, with two miles of track killed two persons in one year, how many would they kill in the same time if they had over 200,000 miles of track as we have? Manifestly they would slaughter over 200,000 innocent people annually. We killed only something over 8,000 persons in the year 1902; therefore, our railway operation is far safer "on the mileage basis" than the one imaginary coral island railway which does not do any real transportation of passengers. In other words, it is safer to do something with a certain amount of risk in it than not to do it. Your chances of drowning when you are in the water are less than when you are on land, according to this strange method of reasoning.

What good can figures derived in such a way do to serious, sensible railroad men who want to know the plain truth in the matter, and who by knowing where they stand may take heed to their ways. These kind of "mileage basis" figures are not worth the cost of the paper and ink necessary to print them, because they convey a false idea

to the mind, and the false is always a poor substitute for the true. We are not at all anxious to praise our friends across the sea at the expense of those at home, but we are concerned in telling the plain truth when it ought to be told. It is always in the interests of honesty and fair dealing to nail the counterfeit coin to the counter, so that its false markings and unreliable figures may never be mistaken for the image and superscription of the true.

The British Isles have a population which stands to that of the United States as 1 is to 1.83. That is not quite 2 to 1 in our favor. We transported in the year 1903 over 8 times our entire population, while British railways carried in 1902 more than 28 times the population of Great Britain and Ireland. The total number of persons who traveled in the United States in 1903, according to Poor's Manual, were 655,139,236, while in Great Britain, 1,188,219,269 persons were carried the year before, which are the nearest years for which figures are published. These figures are in the proportion of 1 to 1.81 or, as we said before, for every 100 persons who traveled here, 181 traveled there. To put these interesting figures another way, we may say that in almost the same proportion that we now exceed Great Britain in population, Great Britain exceeds us in the number of people carried on railways.

In the second part of his pamphlet Mr. Thompson gives expression to the belief that "the lack of strict discipline and the presence of negligence accounts for nine-tenths of the collisions, not only where the block system is used, but where it is not." We agree with Mr. Thompson concerning the lack of discipline, but we entirely disagree with him as to the cause of the laxity. Speaking of the brotherhoods, he says: "But beneficial as these organizations may be in other directions, they exercise an influence over the entire field of railway employment detrimental to discipline." We believe, on the contrary, that the influence of the brotherhoods is such that it tends to strengthen the hands of any railroad operating officer who consistently enforces discipline without heat and passion and without caprice. We do not call it "discipline" for an official to wink at or even smile on a chance-taker making up time by disregard of rules on Monday and to discharge him for unsuccessfully attempting the same thing on Tuesday. The striking picture drawn by this author of the railroad officer always between the devil and the deep sea may be true in some cases, but where it is true the official himself and not the demands of the public or the action of the brotherhoods is generally to blame for his predicament.

A strong, impartial government commission, capable of inquiring into, not only the immediate, but the proximate cause of all railroad accidents, is now in order, and all the more so on account of the growing belief in the public mind that a large number of these so-called "accidents" are really preventable by the strict enforcement of obedience to rules, not for two or three days or a week, but always and all the time. It is the duty of railroad officers not only to emphasize the necessity for taking the safe course in times of emergency, but to see to it that the taking of the safe course in all railroad operation becomes the habit of thought and of action in all branches of the service.

An impartial government examination of every railway disaster, conducted by men who are not under any political pressure, can only be productive of good results. The man who fails in his duty constitutes the weak spot in railroad operation, and the relative importance of the offenders should make no difference in the integrity of the inquiry. If the discipline of the road is lax, the fact must be authoritatively known before a remedy can be applied, and without such authoritative knowledge, improvement is impossible. Where the safety of the traveling public is concerned no fine spun distinction between common clay and exquisite china can hold good. The investigation must be as to the behavior of the railroad employe and the view which an honest court of inquiry must take is that, in the service of the company, there is only an employe in the officials' chair just as surely as there is on the road. The man who is not guilty, high or low, has nothing to fear.

When this is done in a manly and straightforward way all over the country there will be no need to claim comparative safety of operation by multiplying the number of those killed abroad by 9, and then examining our own performance most complacently. We should judge ourselves only by undoubted success actually achieved and there will be no need to mete out blame except to the chancetaker whether he be standing behind the throttle or be clothed with authority and seated in the official's chair. The influence of the brotherhoods one way or other would also stand revealed by such an inquiry as we have described, and we think they have nothing to fear in this respect. What we need are facts, and in this as in all other departments of human life the Biblical statement still holds good: "Ye shall know the truth, and the truth shall make you free."

The Poor Inventor.

No people in the world have displayed so much fertility of inventive ability as Americans, and the Government very wisely provides fairly good and easy means whereby our inventor may protect by letters patent the product of his inventive talents and industry. But one cannot read over the record of patents granted monthly without being impressed with the vast amount of money and energy being constantly expended on devices that can never be of use to the inventor or to any one else. It frequently happens that a man of an inventive turn supposes that an improvement is wanted on some device, such as air machinery or valve motion, and he sets to work thinking and planning and experimenting to devise something better than others have produced. After a time he gets a combination of parts ready, and if they will act even by a stretch of the imagination to actuate a slide valve in a different way from the eccentric, a patent lawyer is applied to and the inventor is protected by letters patent.

We have repeatedly known of inventors mortgaging their homes and other meager belongings to raise the money to defray the expense of obtaining a patent on an article that no one but the patentee imagined had the least claim to merit as an invention. Perhaps it is impracticable to establish a supervising bureau in connection with the Patent Office, but it seems only just that the Government, which accepts the fees of inventors, should provide some means of advising the inventor who is offering to pay for the protection of a worthless device.

When the patent attorneys' fees are paid the poor inventor's outlay on a worthless production is by no means over. As soon as his name appears in the Patent Record he becomes the object of attack by a set of patent brokers who appear to thrive by fleecing patentees on the false pretense that they are able to sell the patent or to have capitalists take an interest in it. He will receive letters from oily knaves, saying:

"We have carefully examined your patent, and find it both meritorious and of practical utility." With a few more words of flattering, in the course of which he may be informed that he is dealing with no patent broker swindling concern, he is requested to send ten dollars to the benefactors of the human race who are addressing him, and he will at once enter the road to fame and fortune through the medium of a patent inventors' association. He may send any number of contributions of money to be expended in advertising by the frauds doing business in the name of an inventors' association, but the chances are that he will never receive any return except renewed promises intended to act as fresh bait. The writer has paid di-

rectly for the knowledge he has on this subject.

The Government makes the best provision possible for the protection of inventions, so far as the rights to the patent are concerned, and this is the means of bringing in business from every part of the Union, many of the persons taking out patents having small opportunity of judging the ways of swindlers who are lying in wait for the unwary. Under these circumstances it would only be fair and just for the Patent Office authorities to take cognizance of the harpies who habitually prey upon the hopes, poverty and want of experience of inventors. Rogues use the U. S. mails to snare their victims. If the Government officials were anxious to stop this species of swindling the crime of using the mails illegally would provide the means of punishment.

At present the poor inventor is like the frog under the harrow; whichever way he turns is only to put himself in the way of receiving a new blow. The Patent Office takes his money and raises his hopes; the sales agents suck out of him his last dollar without rendering him any return; and the public jeer at his misfortunés. There is now and again a big prize for inventors, but the industry is very much of a lottery, where the blanks are as the sands of the seashore in number.

The Real Inventor of the Link Motion.

We were pleased to publish in our March number from the *American Machinist* an article throwing new light on the inventor of the link motion, and we readily hasten to give what justice our publication can do to the man who was robbed of the credit he deserved for the great invention. The story told by D. K. Clark and Zerah Colburn about the invention of the shifting link motion was, that it was worked out by William Howe, a pattern maker in the employ of Robert Stephenson & Co., Newcastle, England, and that a gentleman apprentice in the works had suggested the invention by sketching an impracticable arrangement with the link close to the eccentrics. In 1846, the *Glasgow Practical Mechanic and Engineers' Magazine* published a sketch sent them by Howe pretending to be the plan proposed by Williams and since that time writers on the subject have credited Howe as being the real inventor of the link motion.

Now comes Mr. R. L. Whyte, who was chief draftsman of the Stephenson works when the link motion was invented, with a statement that Howe did nothing for the invention of the link motion further than work out patterns from drawings made according to sketches made by Williams. Mr. Whyte is still alive living in Hamilton, Canada, is in full possession

of his mental faculties, and tells a clear story which indicates that that man Howe was nothing more than a sneaking thief of another man's invention. There have been many such robbers of other people's fame in the world, and we are glad to find that even at this late day a man has come forward to perform an act of justice towards Williams the real inventor of the so called Stephenson link motion.

Book Reviews.

Alternating Currents. By George T. Hanchett, M.E. Publishers, John Wiley & Sons, New York. 1904. Price, \$1.00.

This book, of 175 pages, 7¼x4½ ins., is divided into fourteen chapters. The aim of the author is to explain as clearly and simply as possible, the phenomena as well as the apparatus of alternating currents of electricity in their various practical phases. The book opens with hydraulic analogies of inductance and capacity combinations, and gives the student a sort of working theory of the way alternating currents act. Some subjects treated in the book are single phase constant potential transformers. Phase difference and Vector summation; copper calculations for polyphase circuits; alternating current measurements; the induction motor; the rotary converter; the management of alternating machinery and the management of induction motors. The book is clearly illustrated throughout.

Facts About Peat. By T. A. Leavitt. Publishers, Lea & Shepard, Boston. 1904. Price, \$1.00. Postpaid, \$1.10.

This book, 115 pages, 7¼x4½ ins., deals with peat fuel and peat coke, and tells how to make it and how to use it, what it costs, and what it is worth, with brief notes concerning its use and value for numerous purposes. Among what may be called the chapters or subjects taken up is the intensity of heat generated by peat fuel which is much greater than that produced by coal. Peat as a fuel for generating steam and peat in the manufacture of iron and steel are dealt with. The working of iron is said to be improved by the use of a peat fire, and exceedingly good welds may be made with iron so heated. We are told that peat has been found preferable to all other fuels for case hardening iron and tempering steel. The cost and market value of peat are taken up and discussed and other uses for peat are enumerated. The book is illustrated by a number of good half tone plates which are placed at the end of the reading matter and before the appendix. The book ought to be very useful to those interested in the subject and interesting to the general reader.

QUESTIONS ANSWERED.

(22) H. D., South Omaha, writes:

I have noticed that locomotive cylinders wear more on the top. Can you tell me why this is? A.—The reason why a cylinder wears more on the top than on the bottom is that probably the guides are lined up too low. The wear should take place more on the bottom of the cylinder than on the top with an engine habitually running forward in good shape and with everything all right. Natural wear on the bottom is due to the weight of the piston and rod. On a forward running engine the top guide sustains all the pressure of the crosshead and top guide and crosshead gib wear faster than the bottom, and if there is lost motion between guide and crosshead, the crosshead goes up to the guide at the beginning of every stroke, and when the guides are lined up too low it helps to increase this wear.

(23) I. M. S., Biwabik, asks:

Will you please tell me how the water brake on a locomotive operates? A.—The water brake is the name given to a process of retarding the motion of the driving wheels of an engine usually employed when engine has to do a great deal of drifting for long distances on down grades. There is a small pipe about ¼ in. diameter inserted in the boiler in the cab below the water level and this pipe runs to the cavity in the exhaust passage in the cylinder saddle. When the engine is drifting forward the reverse lever is pulled over into back gear and the cylinder cocks are opened and the valve on the small pipe is opened sufficiently to allow a supply of hot water to be poured into the exhaust cavity. It is then drawn into each cylinder at every stroke and its own stored heat is sufficient to cause it to turn into steam in the cylinders and the pressure thus generated is sufficient to cause a slight but constant check on the speed of the engine. The steam is blown out of the cylinder cocks. This is, in general, the operation of the so-called water brake. A good description with illustrations of the Baldwin back pressure brake, which is a brake of this class, is to be found on page 377 of the September, 1902, issue of RAILWAY AND LOCOMOTIVE ENGINEERING. This back pressure brake is used on some Baldwin ten wheel engines belonging to the Northern Pacific and on nearly all Southern Pacific Company's engines.

(24) M. A. H., Stratford, Ontario, asks:

Should a compound be operated in simple or compound position while drifting? A.—We presume from your question that you are familiar with the latest types of compounds now in use. In answer we would say, work the engine

in the compound position and instead of a closed throttle use just sufficient steam to take up the lost motion in the running gear to overcome the excessive pounding, and to maintain a higher temperature in the cylinders and thus prevent the smoke box gases from entering the cylinders and destroying lubrication. With the two cylinder compound when drifting with closed throttle, the greatest shock is on the low pressure side due to the greater weight of the larger piston, etc. The lever should not go much below half stroke, nor should the starting valve with which the latest compounds are equipped, be set in simple position. It is obvious that to drop the lever in the extreme forward notch is not only wasteful of steam, but very hard on the valves as in that condition they travel a greater distance and materially increase in speed; allowing these things to happen is not considered good practice.

(25) D. C. H., Providence, R. I., writes:

A and B have made a bet on a little mechanical matter. A claims that the piston of a locomotive does not come back when the engine is running forward, and not slipping. He says that the cylinder goes ahead, and the piston does not make a backward stroke. B claims that the piston does make a backward stroke on all occasions whenever the drivers are turning or whether they are slipping or not? Who is right? A.—The man who supports B's argument is right. The piston does make a backward movement in the cylinder. This is a case of relative motion. If you were to uncouple the back end of the connecting rod and lay it down so as to rest against the edge of a tie and were then to use steam with other side of the engine disconnected, the cylinder would relatively move over the piston, because the piston would remain opposite any object on the ground which it happened to be opposite at the beginning of the stroke. But when the butt end is coupled to the crank pin the half revolution of the wheel due to the back stroke carries the whole engine along perhaps ten feet or more, and the crosshead and piston are carried along with it, though the piston is moving from the front cover to the back cover with a positive motion all during the back stroke. See an item called Crosshead Mileage on page 462 of the November, 1902, issue of RAILWAY AND LOCOMOTIVE ENGINEERING.

(26) W. M. C., Rocky Mount, N. C., writes:

A ten wheel Baldwin engine was pulling a passenger train, when about two miles from the terminal, she lost bottom guide bar on right side. Engineer shut off at once and let train drift to station, one mile from where guide was lost.

When train stopped piston rod was found to be slightly bent. Train was taken to terminal one mile further on by another engine. The question is, should engineer have worked steam instead of shutting off, and made station stop with some steam in cylinder and started train and taken it to terminal. In going ahead the pressure of crosshead is all upward and on top guide. A.—When the bottom guide fell off, the engineer should have stopped at once, disconnected butt end and pushed piston and crosshead full ahead and let main rod hang in guide yoke. He then should have placed valve so that steam would enter back of cylinder and hold piston ahead, clamped valve there and gone forward on one side. He should have blocked crosshead as well, as an additional precaution if he had had time. This is good practice but it is probable that the bending of the rod was done before he could stop, because at each of the dead points and especially at the back one, the crosshead drops down onto the lower guide. You can notice this on any engine where the guides and crosshead have much lost motion between them. It is true, as you say, that the pressure of the crosshead is on the top guide in forward motion, but it is equally true that at both ends the crosshead rests on the lower guide for a moment. When the lower guide fell off there was nothing to prevent the crosshead going down too far and so causing the bending of the rod. The reason he should have stopped and disconnected is for fear the rod would keep on bending and do more damage, and the tilting of the piston and running on the edge of the packing rings in the cylinder due to the loss of the lower guide when running shut off would have a tendency to cut the cylinder.

(27) Master Mechanic writes:

I am troubled with stay bolt breakage on a locomotive boiler. The breakage is confined mostly to the six top rows. The bolts are $\frac{7}{8}$ in. in diameter. The lower two are in the ogee. The water space is 3 ins. wide, increasing somewhat above the ogee, as the fire box side sheet is straight and the outside sheet is curved with same radius as the boiler shell, viz.: 28 ins. Pressure carried, 165 lbs. Outside sheet is $\frac{1}{2}$ in. thick. It forms the casings and roof sheets and is without horizontal seam. Fire box side sheet is $\frac{3}{8}$ in. thick. Why do these bolts break? A.—The cause of all stay bolt breakage is the unequal expansion and contraction of the sheets of the fire box and the outside sheet. In the case you cite you have very short staybolts, and the shorter they are the stiffer they are. They resist any force tending to bend them and, therefore, break. The fact that the outer sheet is curved and the inner one not curved, does not help matters, and in the ogee the tendency to break is increased

because the bolts do not stand at right angles to the vertical line of movement of the inner sheets. This increases the strain on the bolt. Another reason is that the outside sheet is heavy, and bolts screwed through it and riveted over are held very firmly, and cannot "give" as they cannot make the sheet bend slightly. Some authorities hold that the side sheets when made thick enough for strength do not require to be as heavy as the roof sheet, and that as far as staybolt breakage is concerned, where short bolts are used, it is preferable to have lighter outside sheets, and two horizontal seams and a heavier roof sheet. In renewing you should try to get as much flexibility as possible in the bolt.

(28) W. T. G., Svensen, Ore., asks:

(1) Which way is considered the best to fit crank pin brasses of a light 30 ton geared locomotive to have the points tight together and keyed up so the brasses are like one solid piece, or file the points to about $\frac{1}{4}$ in. space. The engine to run fast and pull hard? A.—The brasses should be fitted up so that when keyed tightly up they should be free enough on the pin to work without heating.

(2) Is there likely to be any damage to come from filling up a fire box with wet, cold wood, when she has just stopped from a hard pull and is to start up again; would it cause the flues to leak? A.—It might cause the flues to leak if, in order to burn this wet, cold wood, the blower was put on. If the engine is shortly to start again wet, cold wood is not a good way to keep up a good fire.

(3) Is there any more danger of the crank pins getting hot when starting up in the morning on a hard, up hill pull than when they have been warmed up? A.—No, there is not if you see to it that oil gets to the pins from the very outset. When everything is cold oil feeds slowly and a pin becomes hot before the oil gets to it in sufficient quantity.

(4) Will the common D slide valve wear its seat hollow by running with the reverse lever hooked up close to the center? A.—It will wear its seat hollow in time.

(5) Is there danger of breaking off a crank pin by slipping the wheels in starting a heavy load? A.—Yes, there is this danger, especially if one rail is sanded and the other not.

A recent press dispatch from Lafayette, Ind., says: "A grant of \$50,000 has been made by the Trustees of the Carnegie Institution in Washington to Professor Goss, of Purdue University, to be used in research work in locomotive engineering."

Air Brake Department.

CONDUCTED BY F. M. NELLS.

Some Hints on Care of the Automatic Slack Adjuster.

A correspondent writes us, asking why the piston in the small cylinder and the teeth in the ratchet wheel of

mitted to the adjuster cylinder, the pawl would catch on the teeth of the ratchet wheel and become locked on account of the inability of the piston to return to the end of the cylinder.

justers, due to the fact that brake inspectors and other persons engaged in brake shoe and foundation brake gear slack work were not familiar with this unlocking feature, and have attempted by force to run out the slack, resulting in the breaking out of two or more teeth in the ratchet wheel or of breaking the piston itself.

We illustrate herewith cuts of the adjuster which will make clearer our explanation. Fig. 1 shows the familiar attachment of the automatic slack adjuster to the brake cylinder under the car, the predetermined piston travel being set at the point in the cylinder from which the adjuster takes its air pressure, and when the travel reaches this point brake cylinder air is passed to the adjuster cylinder permitting it to operate.



FIG. 1. ATTACHMENT OF SLACK ADJUSTER TO BRAKE CYLINDER.

the automatic slack adjuster are sometimes found broken.

Our brief reply to this question is that when all slack has been taken up that the adjuster is capable of taking the final movement at the device, leaves the pawl engaged in the teeth of the ratchet wheel. If a wrench be now placed upon the nut to turn out the slack, and force is used, either the piston or the teeth in the ratchet wheel will be broken. It is necessary to first disengage these parts before running out the slack.

The automatic slack adjuster is provided with a stop screw which serves

When the jaw comes to the end of its travel it strikes the top screw which holds it a short distance from its extreme traverse, it will be seen that, when this condition occurs, and the pawl becomes caught in the teeth of the ratchet wheel, it will only be necessary to take out the stop screw which will allow the pawl to release itself automatically in the usual manner.

This is a point to which all air brake inspectors and other persons engaged in replacing brake shoes on cars and adjusting foundation brake gear should give their careful attention for, when the adjuster becomes locked, after tak-

Fig. 2 shows the operation of the

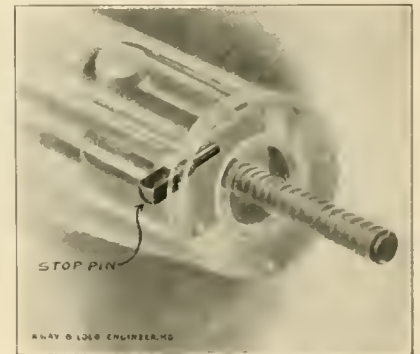

FIG. 3. LOCATION OF STOP PIN.

adjuster cylinder, the pawl and the ratchet. The air admitted to the cylinder pushes out the piston, compressing the spring and engaging the pawl in the ratchet wheel, and the spring returning the piston, after the air has been exhausted from the adjuster cylinder into the nonpressure side of the brake cylinder, and after the pawl has been turned, thus making up a pressure and taking up that much slack.

Fig. 3 shows the location of the stop screw in the housing of the adjuster. When the crosshead strikes this pin, as shown in this cut, the adjuster becomes locked. To unlock the device remove the stop pin and the spring in the adjuster piston will return the piston to release, the pawl will turn the ratchet wheel and release itself, whereupon the slack may be run out as usual.

Fig. 4 shows the location of the stop pin in the adjuster which should be

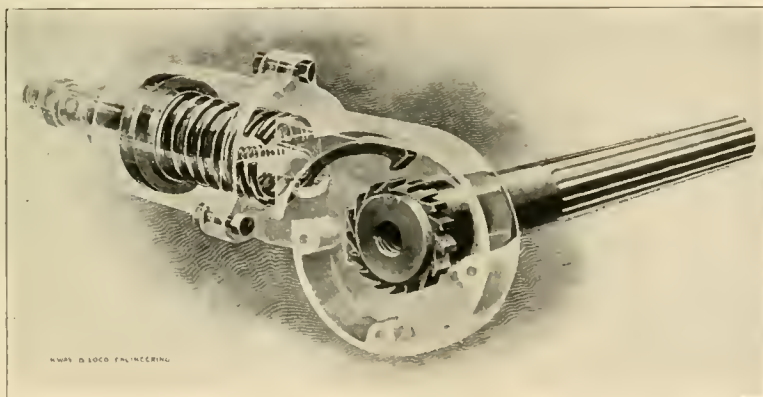

FIG. 2. OPERATION OF THE PAWL AND RATCHET.

to check the movement of the jaw on the adjusting screw near the end of its traverse. If the jaw of the adjuster were free to travel until it came in contact with the outer end of the housing, and if at that time air were ad-

ing up all the slack it possibly can, it is impossible to run out the slack until the pawl has been released from the teeth of the ratchet wheel.

It has been necessary, at times, to renew ratchet wheels and pistons in ad-

removed to unlock the adjuster after all slack has been taken up, new shoes applied and it is desired to run out the slack on the adjuster.

In the older form of adjusters the stop screw was omitted, and in order to unlock the pawl it was necessary to remove the bolts in the ratchet wheel casing so that the pawl could be disengaged.

Coming Convention of the Air Brake Association.

The eleventh annual convention of the Air Brake Association will be held in Buffalo, N. Y., beginning May 10, 1904, and probably running through a three days' session.

The headquarters will be at the Niagara Hotel, which is one block from Niagara street, on Porter avenue.

A splendid list of subjects has been selected and will be reported upon at this convention. In addition to these a series of very interesting topical discussions will take place and, in all, an excellent program has been arranged.

A heavy attendance is looked for, inasmuch that this is the first time the

divisions. Since, to release brakes when set, it is necessary to increase train line pressure above the pressure remaining in the auxiliary reservoir, if we could increase auxiliary reservoir pressure equally with train line pressure,

regardless of the position of the piston in the triple.

The manner of using the device is this: Immediately after making an application of the brakes, and while brakes are still set, move the brake

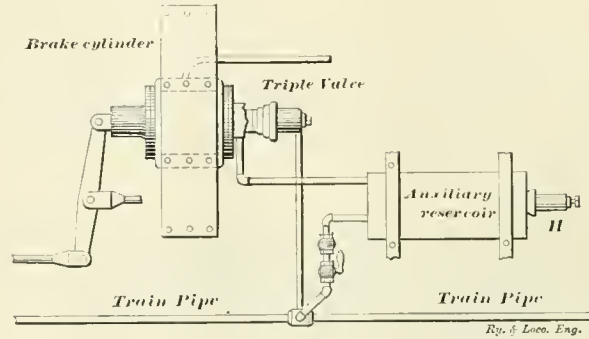

RECHARGING DEVICE ATTACHED TO PASSENGER BRAKE.

then the brakes would not release; or, in other words, would retain until such time as there is thrown into the main line a large amount of excess pressure.

Therefore, would it not be possible

valve handle slowly back to running position. The air flows through the brake valve into the train line from the main reservoir from the train line by the way of the by pass into the auxiliary.

The train line and auxiliary, therefore, will recharge equally, retaining the brakes set until within a few pounds of standard train line pressure. Then, by a sudden movement of the brake valve handle into full release position, the brakes will release.

Safety valves may be put on the auxiliary reservoirs to insure against over charging, and it will be found that it works like a charm.

The release is accomplished by the sudden rush of twenty or twenty-five pounds of excess pressure into the

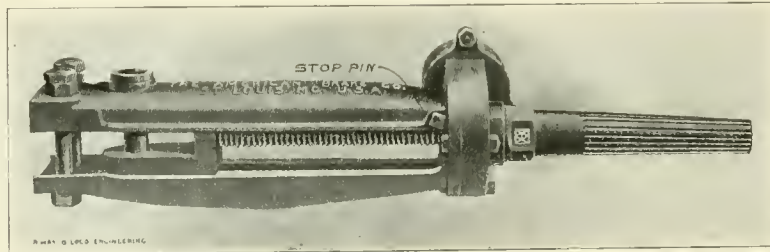
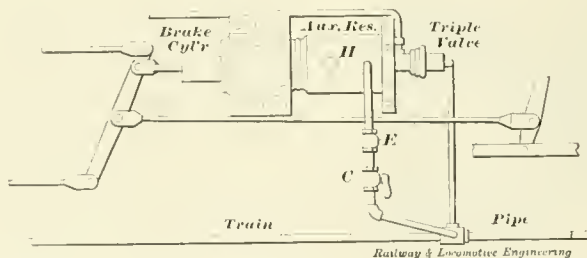

FIG. 4. STOP PIN IN ADJUSTER HOUSING

Air Brake Association has been held in the vicinity of Buffalo. Persons other than members, desiring to attend this convention will be made welcome, and in order to be sure of securing transportation they should make their application for passes as early as possible

to put in a "by pass" pipe with a cut out cock and check in it, the check to retain pressure in the auxiliary reservoir when a train line reduction is made?

This by pass pipe could be tapped into the tee strainer in the train line



RECHARGING DEVICE ATTACHED TO FREIGHT BRAKE.

in order to give the officials time in which to obtain the same.

A Recharging and Retaining Device.

I have a retainer and recharger for air brakes to be used on mountain

and other end tapped into the auxiliary. The cut out would have a small hole in the plug, just large enough to allow air to flow through the by pass into the auxiliary slowly, thereby keeping the train line and auxiliary pressures equal,



BY-PASS.

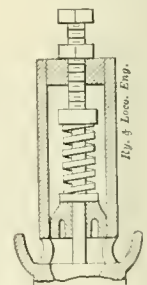

SAFETY VALVE.

train line, and will shove the triple pistons over before the air can feed through the small feed port on the "by pass."

The small amount of air that does feed through into the auxiliary over the normal will quickly escape by the safety valve, rendering sticking of brakes impossible while there is any excess in main drum.

I had an engine and ten cars equipped

with this device, also one coach. They worked perfectly in unison.

HENRY VAN WERT

Coatzacoalcos, Mex.

Air Brakes in Street Car Service.

At the Detroit meeting of the Air Brake Association a valuable report on

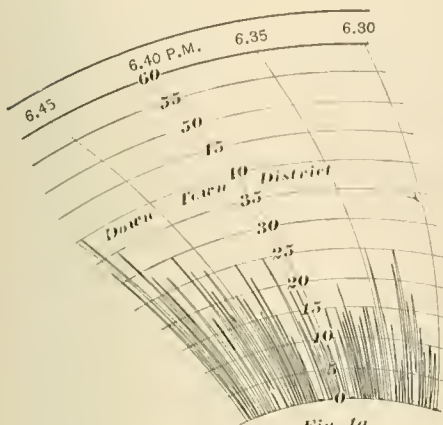

Fig. 1a
Ry. & Loco. Eng.

the use of the recording gauge in air brake service was presented by Mr. George R. Parker, chairman of the committee having the subject in charge. The charts submitted with the report were, however, confined to those taken from train pipe pressure. In a committee report to the convention of 1900, on handling of trains on heavy grades, a number of charts showing pressure developed in the brake cylinder while descending steep grades with heavy trains were shown. Brake cylinder chart No. 14, accompanying the 1900 committee report, was from a train of 53 cars, 40 of which were air braked, weight of

Some time ago the writer had occasion to take some brake cylinder charts from street cars operating in city service, and, believing the results obtained would prove interesting to air brake men generally, send you herewith these charts for comparison with steam road practice.

A connection was made in the brake cylinder direct, with suitable rubber tubing, carried into the car where the recorder was located.

The car was fitted with a straight air brake, and pressure carried in the main reservoir would permit of a cylinder pressure of 60 lbs., if desired.

The car entered service at about 3.27 P. M., at which time the recorder was cut in (see Chart No. 1), and allowed to operate until 6.23 P. M., when the chart was removed. The speed of the chart was three hours for a complete revolution.

The number of brake applications made during this period of three hours was between 370 and 380; those occurring between 5.30 and 6.00 P. M. when the car was in the down town district during the busy hours being particularly close together. Many of the applications were in the nature of slow-

might be said that the car weighed approximately 34,000 lbs., and was braked about 90 per cent. of the estimated weight, based on 60 lbs. cylinder pressure.

Before starting the experiment, the piston travel was adjusted to 4 1/4 ins. standing, and again measured after the nine hours' run, the travel having in-

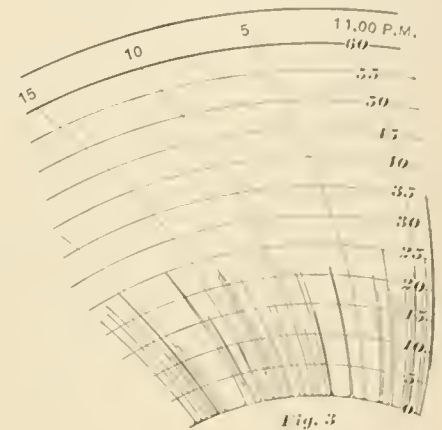

Fig. 3
Ry. & Loco. Eng.

creased to about 5 1/4 ins. The shoes with which the car was fitted were extremely hard, and the brakes being applied but a few seconds at each application, accounts largely no doubt for the small amount of brake shoe wear.

C. P. CASS.

St. Louis, Mo.

A Puzzling Port.

In the number of RAILWAY AND LOCOMOTIVE ENGINEERING for May, last, A. P. Newton, Sydney, New South Wales, inquired as to the object of a small port in the rotary of the equalizing discharge valve. I have been hoping that

R

ATTACH THIS CARD INSIDE OF CAR NEAR Defective Retainer.

ALL CARDS MUST BE ATTACHED ON ONE SIDE OF TRAIN ONLY.

J. C. VINING, TRUN MASTER.

DEFECTIVE RETAINING VALVE CARD USED ON COLORADO MIDLAND R.R.

downs for teams, pedestrians, crossings, etc., but serve to indicate what the street car motorman is "up against" when using a hand brake.

It is interesting to note the highest cylinder pressure obtained on Chart No. 1 was 45 lbs., and that but once, indicating skilful handling on the part of the operator.

Chart No. 2 was taken between the hours of 6.30 P. M. and 8.45 P. M. and, on account of reduced passenger travel, shows less applications for a given time. It will also be noticed a higher average of cylinder pressure was employed after 8.00 P. M., this being due, no doubt, to darkness having fallen and, therefore, less chance to judge speed and points at which the stop was desired.

Chart No. 3 was taken between the hours of 9.15 P. M. and 12.10 A. M., at which time the car was turned into the shed. During the taking of the latter card the speed was slower, owing to the fewer stops required and generally low pressures were used.

As a matter of further interest it

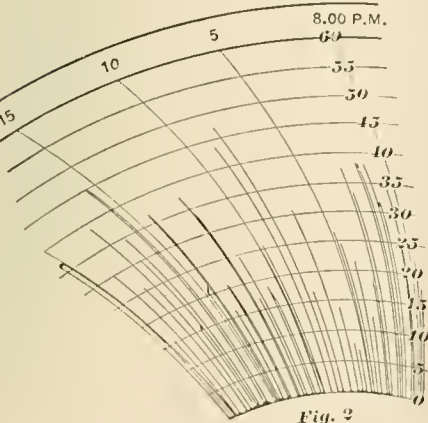

Fig. 2
Ry. & Loco. Eng.

train, about 1,600 tons, and taken while descending a grade of about 2 per cent. Examination of the chart mentioned shows some 14 brake applications during a period of 30 minutes and represents severe grade conditions.

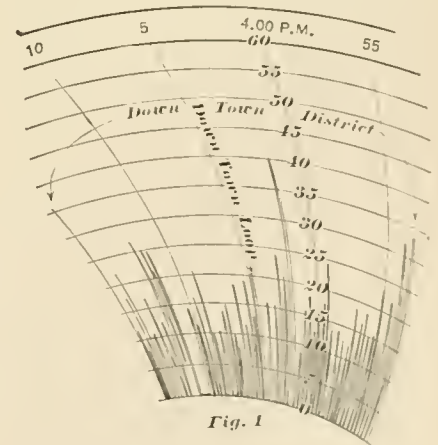

Fig. 1
Ry. & Loco. Eng.

Mr. Newton would make further inquiries, as I think that the way in which he stated his question has led you into mistaking the port he inquires about, for the warning port in the American discharge valve, G 6.

My reason for thinking so is this: New South Wales, like New Zealand, is using the "Made in London" brake, which differs somewhat in construction from the American, although in operation there is no difference. The London equalizing discharge valve was illustrated in the Air Brake Department of April last.

Now, the London people are supplying two valves, the difference being in the excess pressure arrangement, the first valve sent out has the D8 excess pressure valves.

The second valve has the seating and studs as in the F-6 to receive train line governor, but instead of that excellent arrangement, there is a cast iron attachment containing the same excess pressure valve, the valve being in this case placed vertical. It is in this second valve the port in question is found. It registers with the feed port in the rotary seat when in full release and with the equalizing port with the handle about 3/4 in. from emergency stop.

It will, therefore, be seen that this

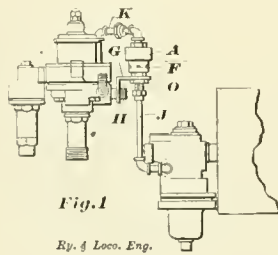

Fig. 1

By. & Loco. Eng.

cannot be a warning port, as it is never in communication with any port through which it can give warning. Of course, Mr. Newton was right in saying that it was "situated to the right of the excess pressure port." It is so if seen from above. The G 6 warning port would also be to the right, looked at from below; hence the mistake. Can you tell us now what the object of the port is?

J. F. GREIG.

Palmerston, New Zealand.

[Our correspondent most probably refers to the driver's equalizing valve, which is fitted with the simple feed valve, or excess pressure valve, in which case the port referred to is not necessary in the valve's operation, but does no harm. However, this port is necessary when the slide valve feed valve, or train pipe pressure regulator is attached to the equalizing brake valve. In this case, when the rotary of the brake valve is in full release position, this small port maintains full main reservoir pressure on the back of the slide valve feed valve and thus prevents the valve from being forced off its seat by any excess of pressure on the other side. In short, the port

functionates only when the slide valve feed valve attachment is used on the driver's brake valve, and not when the ordinary excess pressure valve, or simple feed valve is used.—Ed.]

Air Brake Retaining Device for Locomotives.

The object of the device is to provide means for maintaining the driver

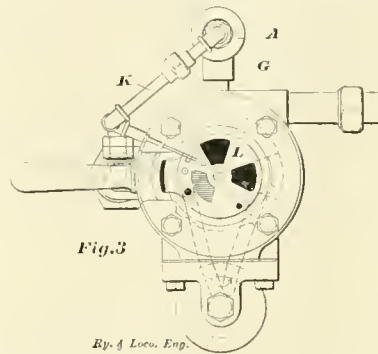

Fig. 3

By. & Loco. Eng.

brakes in operation after the train service brakes have been released. It consists in modifying the engineer's brake valve and making additional connections between the essential elements of an air brake system located upon the locomotive, whereby the brakes upon the same may be operated independently of those upon the balance of the train.

Figure 1 is a diagrammatical view showing an engineer's brake valve, triple valve, the retainer valve and connections between said parts.

Figure 2 is a vertical sectional view through rear retainer valve.

Figure 3 is a plan view of the valve seat of an engineer's brake valve of well known construction, showing our improvement applied thereto, and

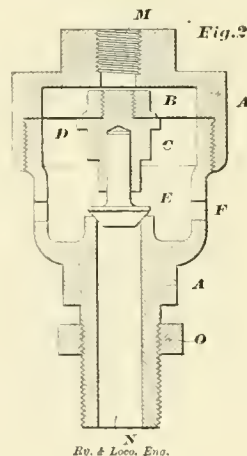

Fig. 2

By. & Loco. Eng.

Figure 4 is a bottom plan view of the rotary element or valve proper showing our improvements thereto.

Referring more particularly to the drawings, "B" denotes the shell or casing of an engineer's valve, of the

usual and ordinary parts, including the rotary valve. The improvement to this valve consists in providing in the valve seat of passage "L" (Fig. 3), which is preferably formed by drilling a small hole vertically down through the seat and another horizontally through the hole "B" (Fig. 1), to communicate with the bottom of the vertical passage.

The rotary valve is provided in addition to its usual ports with a port or opening "L," which is adapted to register with the passage "L" in the valve seat when the valve is in the "full release."

The rotary is also provided with a groove "P" (Fig. 4), upon its under face, which is adapted to afford communication between the passage "L" in the seat and the main exhaust of the valve when the latter is in the "running position."

"X" denotes the exhaust port in the ordinary Westinghouse type of triple valve, which is connected by the pipe or connection "J" to the lower end of the retainer valve "A." A pipe or other connection "K" is tapped into the horizontal portion of the passage "L" in



Fig. 4

By. & Loco. Eng.

the engineer's valve and connects with the top of said valve "A."

The retainer valve "A" comprises the body portion or shell "A" (Fig. 2), and a screw cap between which is held the diaphragm "D" to which the stem or guide sleeve "C" is attached by the nut "B."

The said sleeve guides the upper end or stem of a valve "E" which is adapted to co-act with the valve seat formed in the lower portion of the body, and to control an exhaust of the triple valve through the pipe "J."

A compartment or chamber in the body of the retainer valve below the diaphragm and above the valve "E" is in communication with the atmosphere, through the openings or apertures "F" in said body portion. The compartment in the cap above the diaphragm is in communication with the passage "L" of engineer's valve through the pipe "K."

The retainer valve may be attached to the engineer's valve in any desired manner, but preferably as shown in the

drawing, by providing the angled bracket "G" (Fig. 1), which is secured to a stud or connection upon the engineer's valve "H" and by forming the lower end of the body of the retainer valve with a threaded end, which passes through an aperture in the bracket and is locked upon the same by the nut "O."

In the operation of the invention, when the handle of the engineer's valve is turned to the "full release" position, the port "L" in the rotary valve (Fig. 3), will register with the passage "L" in the valve seat, and thereby permit the air from the main reservoir to pass through the pipe "K" to the retainer valve "A," above the diaphragm "D" (Fig. 2), in order to hold the valve "E" upon its seat, and thus retain the pressure in the driver brake cylinders by preventing the exhaust from the triple valve, and, consequently, hold the brakes on the engine set, while the train service brakes are being released.

In order to release the driver brakes the handle of the engineer's valve is turned so that the rotary valve is in the "running position," when the groove "P" (Fig. 4), upon the same, will afford communication between the passage "L" and the main exhaust of the engineer's valve in order to permit the air in pipe "K" and in the compartment above the diaphragm "D" to exhaust, and thereby release the valve "E."

The exhaust from the triple valve at the port "X" will then pass through the pipe "J," valve "E," and out through the opening "F" to the atmosphere, and the driver brakes will be thereupon released.

S. B. HAMILTON.

Toronto, Ont.

QUESTIONS AND ANSWERS

ON AIR BRAKE SUBJECTS.

(26) J. W., Tocco, Ga., asks:

What effect has a leaky graduating valve on the brake? A.—It will release a set brake, if the leakage of the auxiliary reservoir pressure past the graduating valve can escape to either the atmosphere or the brake cylinder in sufficient quantity to permit the triple to go to release position.

(27) M. J. F., New Haven, Conn., asks:

Why is the push rod loose in the sleeve in freight equipment and bolted rigid to cylinder lever in passenger equipment? A.—Because it is undesirable to move the piston in the brake cylinder each time the hand brake is set, as that would tend to wear out the leather packing unnecessarily. Owing to the different types of foundation brake gear on passenger and freight

cars, the former type pushes the piston harder into the brake cylinder when the hand brake is set, and works opposite to the air. On the freight car the push rod only pulls out when the hand brake is set, and works in the same direction with the air.

(28) E. W. E., Paterson, N. J., asks:

If the main reservoir is full of water, or nearly so, will a 9½ in. pump pump up standard pressure; if not, why not? A.—A 9½ in. pump, or any other pump, will pump the same pressure into a main reservoir having either a small volume or a large volume, providing proper time is allowed. In pumping up a small volume the work would be accomplished in a much shorter time than in a reservoir of much larger volume. In other words, the presence of water in the reservoir would have nothing to do with the pumping up of the pressure except that the space the water occupies would lessen in that amount the space to be occupied by air, and would, therefore, allow less air to be placed in that reservoir. The presence of water in the main reservoir reduces the volume, thereby robbing the brakes of that amount of air pressure which the water occupies. In the event of releasing brakes, there would be less volume to draw from, and the air pressure would not reach as far as if the reservoir were free from water. Again, the air would take up moisture from this water in the main reservoir and carry it back in a certain degree into the train pipe, but the presence of water in the reservoir would not prevent the pumping up of pressure to the standard.

(29) A. R. L., Philadelphia, Pa., writes:

Why do we find so many of the pistons in the little cylinder of the automatic slack adjuster broken, and why are so many teeth broken out of the ratchet of this machine? A.—The breakage of these parts is due to an attempt of the car repair man, or other man, putting new shoes on the car, to run out the slack adjuster when all the slack has been taken up to the limit of the machine, without removing the small stop screw in the side of the adjuster. When the slack is all taken up as far as the machine will take it, the pawl has reached out for the last time and is left locked in the teeth of the ratchet wheel. In order to release this pawl, the square headed stop screw must be removed from the side of the machine, and the pawl will release at once, and the slack can be run back without difficulty. However, if force is applied to run out the slack without removing the stop screw, the pawl

remaining in the teeth of the ratchet wheel will be unduly strained, and either the teeth or the pawl piston will break. In adjusters not supplied with the stop screw, the outer casing may be removed and the pawl released. See further illustration of this subject elsewhere in this department.

(30) C. P. McG., Chicago, Ill., writes:

In the 1903 edition of Conger's Air Brake Catechism, an explanation of figuring braking power pressure on pressure reduction of train line. I don't quite see where the 15 lbs. atmospheric pressure comes in. Still it is a case where piston displacement is involved. I should like very much to have this made plainer if such is possible. A.—This matter puzzles most air brake men, more or less, until it is thoroughly understood. Suppose, for example, before the brake is applied, that by the most artificial means such as pulley tackle or other arrangement, we were to couple onto the piston rod and cylinder end of the cylinder lever, and pull the piston out of the brake cylinder, thus forcing the brake shoes tight up against the wheels. If the leather packing and other connections to the brake cylinder are perfectly tight, there will be a perfect vacuum or 14.7 pounds below the outside atmospheric pressure in the air cylinder resisting the efforts of the pulley tackle and tending to draw the piston back again. If a vacuum gauge were attached to this cylinder it would show a vacuum of 14.7 lbs. per square inch. Now, if pressure from the auxiliary reservoir is permitted to pass to this cylinder, containing the vacuum or negative pressure, 14.7 lbs. will be consumed in destroying the vacuum and making a pressure therein equal to the atmospheric pressure outside. Then, further pressure being passed from the auxiliary reservoir to the brake cylinder, would begin to register on the ordinary air gauge. In reality, the cylinder has received the amount of pressure registered on the ordinary air gauge, and in addition to this, 14.7 lbs. have also been passed to the cylinder and actually been eaten up to destroy the vacuum. This special case of pulling out the brake piston artificially has been used for illustration, but the same amount of air from the auxiliary reservoir would have been consumed had it been permitted to pass into the brake cylinder in the ordinary service way, instead of having the piston pulled out and the vacuum produced, for the first air passing to the cylinder destroys the vacuum produced by the outward movement of the brake piston, and builds up gauge pressure simultaneously.

Growth of the Locomotive.

BY ANGUS SINCLAIR,

(Continued from page 62.)

After making a fair start in railroad construction, the people of New England displayed vigorous enterprise in pushing the work of providing means for quick land transportation. Statistics show that in 1850 there were 8,589.79 miles of railways in operation in the



WILSON EDDY.

United States, of which 2,507.48 miles were in New England. The State of Massachusetts alone had 1,035.74 miles, being exceeded by only one State of the Union, New York.

GROWTH OF LOCOMOTIVE BUILDING IN NEW ENGLAND.

The New England States being the principal seat of manufactures of a metallic character at that time, it was natural that the people should expect that their mechanics would secure the greater part of the business of building locomotives for railroads throughout the whole country. A good start was made in this industry and it prospered for years, but its glory has now departed, and New England has now ceased to build the locomotives needed for operating its own railroads.

The loss to New England of its locomotive building business is a curious illustration of trade vicissitudes. Within the first three decades of the railway era thirteen or fourteen different works had built locomotives in New England and some of them were for a time among the most prosperous establishments of the kind in the world. One or two of the first locomotives built in New England were turned out of a shop on the Mill Dam, now South Boston, and then came the Locks & Canal Company of Lowell. After them came Hinkley & Drury, followed by John Souther of Boston, Seth Wilmarth of Boston, Taunton Locomotive Works of Taunton, Amoskeag Locomotive Company, Manchester, N. H.; Mason Locomotive Works of Taunton, McKay & Aldus of

Boston, Lawrence Machine Works of Lawrence, Mass.; the Manchester Locomotive Works and the Portland Locomotive Works, Portland, Me.; and the Rhode Island Locomotive Works, Providence, R. I.

LOCKS & CANAL COMPANY'S WORK.

The first concern to establish any mark as locomotive builders in New England were the Locks & Canal Company, Lowell, Mass., which afterwards became known as the Lowell Machine Shops Company. They began building locomotives in 1834 owing to prostration of their canal operations due to the depression in that kind of business through the growth of sentiment in favor of railroads. The Locks & Canal Company took the Stephenson's Planet type of locomotive for their model, and built quite a number of them for different new England railroads. These engines had a single pair of driving wheels in front of the fire box inside connected and one pair of carrying wheels under the smoke box. As the proportions of these engines became for a time the prototypes followed by the early New England locomotive designers, their dimensions will be of interest to people interested in locomotive development.

THE MODEL PIONEER LOCOMOTIVE OF NEW ENGLAND.

The cylinders were 11x16 inches, the driving wheels 5 feet diameter outside of the tires, and the leading wheels were 3 feet diameter. The boiler had a slight wagon top with dome on top and was 34 inches diameter, containing 66 copper tubes $2\frac{1}{4}$ inches outside diameter, and 82 inches long. The fire box was 22 ins.

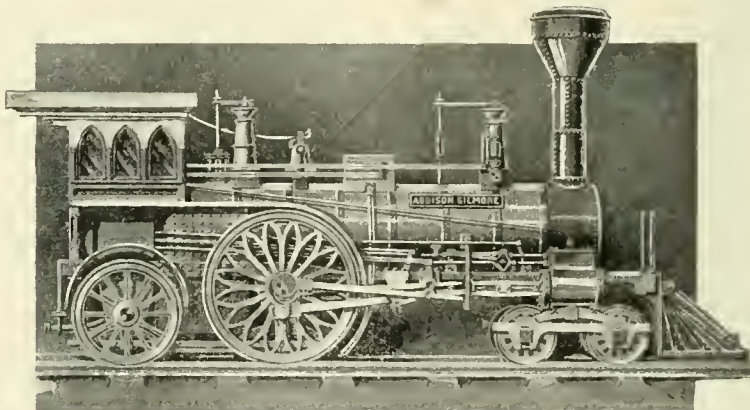

ADDISON GILMORE, EDDY'S FIRST ENGINE, 1851.

long inside, 42 ins. wide and $37\frac{1}{2}$ ins. deep, the grate area being 6.4 square feet. There was about 37 square feet of heating surface in the fire box and about 262 square feet in the tubes, making a total of about 300 square feet of heating surface.

The engine had drop hook valve motion operated under the smoke box. The steam ports were $1\frac{1}{4}$ x6 ins., and the exhaust port $1\frac{1}{2}$ x6 ins. There were two

nozzles each $1\frac{1}{2}$ ins. diameter. The engines weighed in working order about 23,000 pounds, of which 14,500 was on the driving wheels. The fuel burned was wood.

The Lowell Machine Shops suspended locomotive building after they had turned out about twenty engines, but in 1847 they tried that line of work again and built two engines for the Boston & Lowell Railroad, which displayed some development, for they were four wheel inside connected with a four wheel truck in front. The cylinders were $15\frac{1}{2}$ x18 ins., the driving wheels being 66 ins. diameter. That ended the work of the first locomotive building company in New England. Their engines never were popular and made little mark on the art of locomotive building.

HINKLEY & DRURY'S START IN LOCOMOTIVE BUILDING.

In 1839 Hinkley & Drury began locomotive building in Boston, their first engine being the "Lion," which was carried on four wheels connected and had outside cylinders. That engine resembled the De Witt Clinton, belonging to the Mohawk Valley Road, but had a slightly larger boiler with a small wagon top fire box and a big dome on the middle of the boiler. Hinkley & Drury engaged seriously in the work of locomotive building and eventually turned out many excellent locomotives that compared favorably with the productions of the best shops in the country. In their second engine they yielded to the popular trend of New England practice, introduced by the Locks & Canal Company, and made an inside connected and four wheel con-

nected engine which had, however, a four wheel truck in front. This practice of building inside connected engines was followed by Hinkley and Drury for about ten years, until the demand of railroad companies for outside cylinder engines induced the builders to conform to the popular taste and do away with the necessity for a cranked axle.

It is curious how wedded some men become to the idols of their own con-

struction. Isaac Hinkley, the head of the Hinkley Locomotive Works, reluctantly consented to build outside connected engines; yet it is said that on his death bed he expressed the belief that the most serious mistake of his life was changing from the making of inside to outside connected locomotives.

The Hinkley Locomotive Works built up a good business very rapidly and some of their engines became famous. The "Antelope," built for the Boston & Maine in 1845, had a single pair of drivers 6 ft. diameter, a four wheel truck in front and a single pair of carrying wheels under the foot plate. This engine was noted for fast running, but was too much given to slipping to hold popularity. Express engines with a single pair of large driving wheels were then becoming popular in Europe and many of them are still to be found at work there; but they have never been successful in the United States, although many of them have been tried at various times.

LARGE DRIVING WHEEL ENGINES.

The early locomotive designers the world over made a common mistake of imagining that the size of driving wheels, instead of the size of boiler, controlled

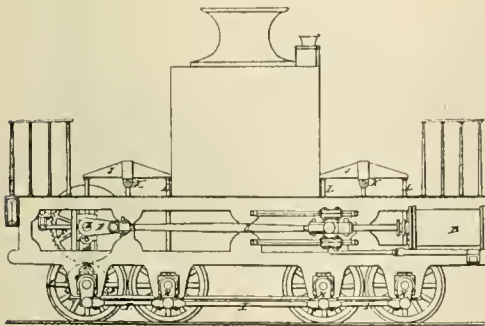

ROSS WINANS' ENGINE. FOR WESTERN RAILROAD OF MASS., 1843.

the speed capacity of a locomotive, and American designers did not keep clear of the fallacy. This sentiment was what led to the building of the Stevens' Crampton engine for the Camden & Amboy Railroad with driving wheels 8 ft. diameter, illustrated and described on page 544 of our 1903 volume. A few others noted for the large size of their driving wheels and the small capacity of their boilers were built, and provided object lessons that were not soon forgotten.

The "Stevens" already mentioned was the first engine conspicuous for its great size of driving wheels. In 1849, the year that the Stevens was put to work, Edward S. Norris, of the Schenectady Locomotive Works, built the "Lightning" for the Utica & Schenectady Railroad, with a single pair of driving wheels 7 ft. diameter, cylinder 16x22 ins., boiler 42 ins. diameter, with 116 2 in. tubes 10 ft. 3 in. long, providing about 670 sq. ft. of heating surface. About one year's serv-

ice proved the engine to be a failure. The "Mam Luke," built by the Amoskeag Company in 1849, had inside cylinders

and locomotive designers went gradually back to driving wheels about 5 ft. diameter, which was the popular size for many years and



LOWELL ENGINE, BUILT ABOUT 1837, REBUILT 1846, BELONGED TO STONINGTON RAILROAD. JAMES M. ANDERSON, MASTER MECHANIC OF ROAD, IN FRONT. Photograph from which engraving was made loaned by Mr. Orman L. Pratt, Providence, R. I.

15x24 ins. and two pairs of coupled driving wheels 7 ft. diameter. The "Carroll of Carrollton," made by Ross Winans in 1852, had a single pair of driving wheels 7 ft. diameter, and had four wheel trucks in front and rear.

Winans tried to strengthen the weak point of previous single driver engines, viz.: deficiency of adhesion, by providing the "Carroll of Carrollton" with a traction increaser shown in the engraving of the engine, but it did not secure success, for the engine never did any regular work.

The Philadelphia & Reading, also the Hudson River Railroad, each had two locomotives built by the Trenton Locomotive Works, Trenton, N. J., with single pair of driving wheels 7 ft. diameter which seemed to be the standard size for that style in those

were quite large enough for the prevailing speed of trains. As late as 1864 the average speed of express trains in the United States was 32 miles an hour for a few of the most important lines, and 26 miles an hour on others with long mileage.

THE LOWELL LOCOMOTIVE RACES.

While the movement favoring high speed of locomotives was at its height, the New York Association of Railroad Superintendents arranged for a contest of locomotives to demonstrate both speed and hauling power. This extraordinary event took place on an unused portion of the Lowell Railroad belonging to the Boston & Maine system in October, 1851. The distance run was 8 miles 36.16 ft. A committee consisting of scientific and practical men was in charge.

The *American Railroad Journal*, February 14, 1852, gives the following ac-

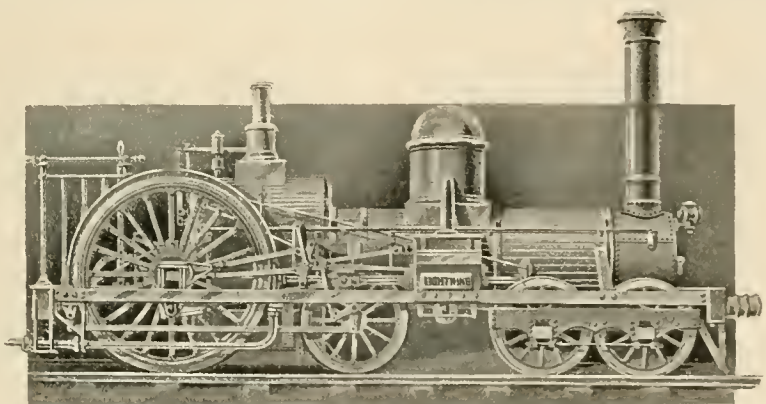

LIGHTNING, BUILT BY EDWARD S. NORRIS AT SCHENECTADY LOCOMOTIVE WORKS, 1849.

count of the competition as being the committee's rules and findings: "The trial of locomotive engines for

When the short lived movement in favor of big driving wheels died out, the loco-

speed and draught was held on a piece of unused track belonging to the Boston & Maine Railroad, and under control of the New York Association of Railway Superintendents.

pared with the others, to which is to be added the consideration that she was worked at a pressure above that proposed by the committee's rules.

"The Dedham, a small tank engine,

tail with the others, but with such disproportionate load, we think it inexpedient to make any comparisons.

"The trial of the freight engines was made upon the track connecting the Boston & Maine R. R. at Wilmington, over a distance of 9,100 ft. in length. The load consisted of 114 loaded cars, estimated to weigh, cars included, 650 tons.

"Each engine first backed its train down to the starting point, which was at the top of an inclined plane of 14 ft. to the mile, and from this point was started at a given signal, making their best time to the point at the other extremity of the course.

"The time of the passenger engines was:

	Weight, Tons.	Time.
Neponset.....	43,775	13 min. 25 sec.
Nathan Hale.....	47,993	12 " 30 "
Addison Gilmore.....	50,885	11 " 29 "
Union.....	46,320	13 " 28 "
Addison Gilmore M.....	46,320	14 " 25 "
Essex.....	48,470	14 " 33 "

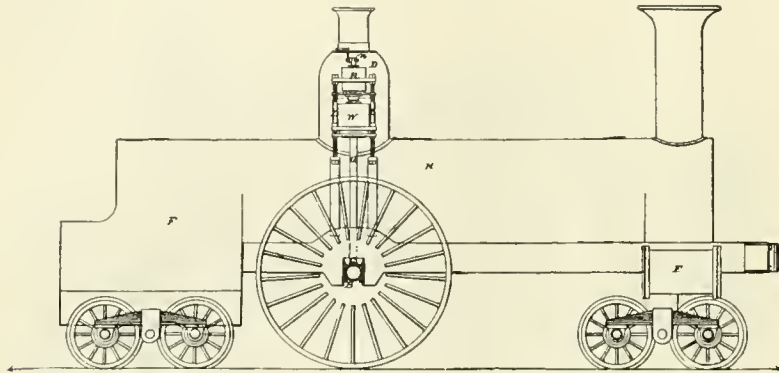

CARROLL OF CARROLLTON, ROSS WINANS' IDEA OF HIGH SPEED ENGINE, 1852.

"The rules adopted were:

"First.—That all engines upon this trial should carry the same load over the same distance.

"Second.—That the pressure of steam in the boilers should not exceed 120 nor be less than 70 lbs. per sq. in.

"Third.—That the pressure at starting should be taken as the pressure at which the engine worked over the whole distance, the safety valve balances remaining unaltered.

"The constant load in the trial of speed consisted, besides the tender, of six covered freight cars each loaded with five tons, one long passenger car and twenty-one passengers, the whole weighing 85 tons.

"The report shows we have confidence that equal justice has been done to all, with exception of the Addison Gilmore, of the Connecticut & Passumpsic River Road.

"This engine was worked at a much higher pressure than the others and would, under the circumstances, have

built by G. S. Griggs for the Boston & Providence Road, was run over the

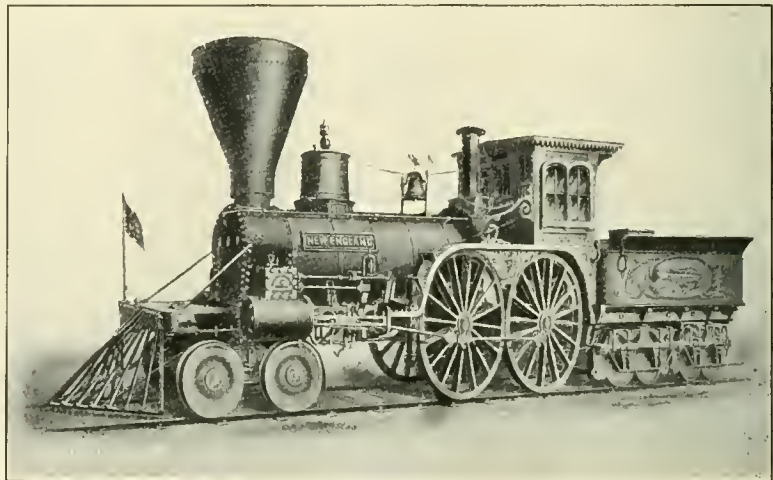

TAUNTON, 1860

same track on the day after the trial of the other passenger engines, with a

"The time made by the freight engines was as follows:

	Weight, Tons.	Time.
Milo.....	38,900	10 min. 24 sec.
St. Clair.....	48,650	10 " 54 "
Highlander.....	40,015	12 " 38 "

"Of the passenger engines, the first medal was awarded to the Addison Gilmore, of the Western Road; the second, Nathan Hale.

"Of the freight engines, the first was awarded to the Milo, the second, to the St. Clair."

The Lowell competition was a proceeding emanating from good intentions that proved of no value, as generally results with competitions of things mechanical. It might suggest a useful lesson to the people to-day who are promoting automobile races.

The "Addison Gilmore," mentioned as receiving the first medal in the Lowell competition, is a historical engine which exerted considerable in-

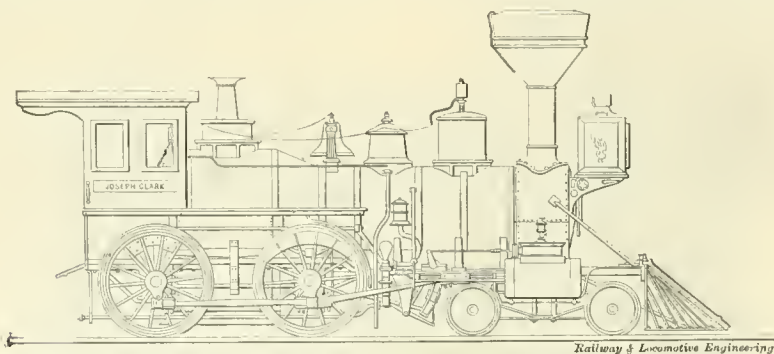

FAMOUS MORRILL ENGINE, BUILT BY VERMONT CENTRAL RAILROAD ABOUT 1863. From drawing loaned by E. R. Russell, Burlington, Vt.

had a decided advantage, but as she had just come from the shop and never had been attached to a train, it is difficult, if not impossible, to arrive at a correct estimate of her power as com-

load of two passenger cars and 81 passengers, making the entire weight 18 tons.

"The time in which this engine passed over the nine miles is given in de-

fluence on settling the form of what was so long known as the American locomotive.

LOCOMOTIVE BUILDING BY WILSON EDDY.

Wilson Eddy, the designer and builder of the engine, was born in 1813, and served his apprenticeship as a machinist in the noted Lowell Machine Shops, successors to the Locks & Canal Company, where he worked on building the engines already described. While there he worked on the first iron planers built in this country.

Major Whistler, a celebrated pioneer railroad engineer, had charge of what are now the Western divisions of the Boston & Albany Railroad, then known as the Western Railroad. In 1840 he employed Wilson Eddy as foreman of the Springfield shops, and he displayed engineering ability of first class order.

The road used mostly the English type of engine, built by the Lowell Machine Shops Company, but they also had eight Winans engines with upright boilers, the machine being something of the "crab" type, but eight wheel connected, as seen in accompanying engraving.

In 1849 Mr. Eddy drew the plans for his first engine, but the facilities for doing the work of locomotive building being very meager, the engine was not finished until early in 1851, time enough, however, to be in good working order when the Lowell contest took place. This engine was called the "Addison Gilmore," after the president of the Western Railroad. As originally built, the engine had a single pair of driving wheels, 6 ft. 9 ins. diameter, a four wheel truck in front, and a single pair of trailing wheels under the foot plate. The cylinders were $15\frac{3}{8} \times 26$ in. stroke, and the weight when working was 51,000 lbs.

Up to this time that Eddy built his first engine, the locomotive builders of New England were noted for the small fire boxes and grate area provided for their engines, from 7 to 9 sq. ft. being the common practice. Eddy provided the Addison Gilmore with $11\frac{1}{8}$ sq. ft. of grate area; there were 68 sq. ft. of heating surface in the fire box and 1,107 in the tubes, of which there were 196, 12 ft. 4 ins. long, and $1\frac{3}{4}$ in. diameter. The total heating surface was 1,175 sq. ft., which was up to modern practice in ratio of cylinder contents to heating surface. A single exhaust pipe was used with a single nozzle, $3\frac{1}{4}$ in. diameter.

The advanced ideas of Mr. Eddy may be judged from the comparison that the "Antelope," already referred to as a noted engine built by Hinkley & Drury, in 1845, with driving wheels 6 ft. diameter, intended to pull the fastest trains of the period, had only 8 sq. ft. of grate

and 300 sq. ft. of heating surface to generate the steam required by cylinders $11\frac{1}{2}$ ins. diameter and 22 ins. stroke.

THE "ADDISON GILMORE."

The Addison Gilmore had horizontal cylinders outside of the frames, being the first engine so built. One of the most notable improvements introduced was spliced frames, which effected great saving in making repairs. This improvement has been credited to William Mason, but Eddy's engine was built two years before Mason commenced the business of locomotive building. While Eddy arranged his cylinders level, he did not spread the truck wheels to make room for them, but placed the cylinders high enough to clear the truck wheels. I believe that Mason was the first to spread the truck wheels to make room for the cylinders, but Eddy had moved in that direction.

The arrangement of a single pair of



WILLIAM MASON,
Noted Locomotive Builder.

driving wheels with a pair of trailing wheels behind did not work any more satisfactorily in Eddy's design than it did with Baldwin, Rogers, Hinkley and others, and after a brief period of service, a pair of driving wheels took the place of the trailers. No cab was put on the engine at first, as there was a prejudice in New England at that time against covering in the enginemen. Oil cups were placed on the boiler head for lubricating the cylinders, and pipes led from them to the top of the steam chest, that being the first case where such a convenience was provided.

The boiler was straight and had no dome, the steam being conveyed through a perforated dry pipe. The throttle was a plain slide valve located in the T pipe in the smoke box, the operating rod extending through the dry pipe to the back boiler head. The slab frames used back of the front driv-

ing wheels were bolted to the side of the fire box, the expansion being provided for by movement at the cylinder connections. This arrangement made room for a fire box about three inches wider than that of engines having bar frames.

INFLUENCE OF EDDY'S WORK.

Eddy built many locomotives during the forty years he was with the Boston & Albany Railroad, and the Eddy Clocks, as his engines were popularly called, were held in high esteem, even affection, by enginemen, and never were beaten for efficiency and economy. A peculiarity about all Eddy engines was their short steam ports, which were only 8 ins. long for cylinders $18\frac{3}{4} \times 28$ ins.

Decided difference of opinion now exists concerning the influence of Eddy's locomotives on the motive power of this continent. One thing is undeniable—he made engines convenient to operate, easy to repair and so proportioned that maximum wear was secured before heavy repairs were necessary. As we examine the locomotives built between 1850 and 1860 when something approaching uniformity of appearance had been reached, we are moved to believe that the influence of Eddy and of Mason were far reaching.

The illustrations in this issue fairly represent the trend of locomotive designing in New England up to the sixth decade, when the smaller size of the modern engine was coming into general use.

(To be continued.)

Men the Best Safety Appliances.

Mr. P. H. Houlahan, superintendent of the Hannibal & St. Joseph Railroad, in a recent newspaper interview with a reporter of the Kansas City *Star*, remarked:

"You can labor from now till you are 100 years old in trying to equip railroads with every conceivable device to secure safety and yet you will have disasters unless you realize the great fundamental requirement of judgment—brains. No invention, however efficient, will take the place of a man with a cool head, who can reason rapidly and accurately in times when lives are hanging on seconds. Block signals may become clogged and fail to work, a telegraphic order may have a doubtful meaning, a switch lamp may be turned wrong, or a hundred other things may happen that would furnish an excuse for a man to say, 'It wasn't my fault.' But going down to the bottom of railroading, you want to impress upon men who have to do with the running of trains that their judgment is the real reliance; their knowledge of what to do when the emergency arises. You will notice from reading accounts

of railroad wrecks last winter that some of them were on lines equipped with every known device to prevent just such accidents as happened.

"I am not one of those who believe men should be retired from active service when they have passed 40 or 45 years. It requires from 35 to 40 years to ripen some intellects into perfect judgment. The man of 40 generally has been tried by fire, and he thereafter avoids the conflagration. Like the general on the battlefield, he knows what's best to do. A younger man might take his chances on a sharp curve or over a yard full of switches. The veteran will begin to cut off steam at the proper moment and reduce his speed, making up the time on the next fair stretch.

"Brains are a matter of development in railroading as in everything else. You can't find any mechanical substitute though you line the track from beginning to end with automatic devices. Just as you come to rely on mechanics instead of men, just in proportion will accidents increase. When I'm riding in a sleeper I rest easier if I know there's a man of nerve and judgment in the cab than were the way sparkling with signals. I'm a friend to every possible appliance for safety, but I'm a greater believer in a system that relies upon human agencies as the chief safeguard. The reason? Why, God made man, and man made the inventions. The Master's work is the better."

How to Earn Success.

The American mechanic has the advantage of his class in all other countries in the fact that he is regarded as a gentleman so long as he behaves in a manner to deserve that title. Remember that the mechanic who thinks and studies, who seeks good society, who is cleanly in person, self reliant, obliging and courteous is the mechanic who is bound to rise in his business. We frequently hear the complaint that machanics have no chance for advancement nowadays, but those best able to judge insist that the mechanic's opportunities were never better than they are to-day. A mechanic is like every other man earning a living, he must deserve success in order to secure it. The man who spends all his leisure hours in idleness seldom rises above routine labor, and he does not deserve anything better.

Below the Fare Paying Age.

"You'll have to pay half fare for that boy, Madam," said the conductor. "He is certainly over five years old."

"Indeed he is not," protested the mother. "I have taken that child free for six years, I'll have you understand, and I don't intend beginning to pay fare for him now."

Signals and Signaling.

BY GEORGE S. HODGINS.

(Continued from page 115.)

THE CONTROLLED MANUAL SYSTEM.

We have hitherto considered automatic block signals, and we now come to the examination of the system which was developed from telegraph blocking and which was in use before any automatic system had been devised. The controlled manual, or as it is called in England, where it originated, the "lock and block" system, has been brought to a high standard of operative efficiency. The system is used on the New York Central and several others of our leading railways.

The controlled manual, as its name implies, introduces the human element, but under it human action is limited in certain particulars, and the liability of mis-

heavy pull, an electric motor is used. The human element also brings a certain order of intelligence to bear on the signaling problem. The man in charge of the apparatus can report defects and he can promptly ask for assistance in time of need. The machine part of the system furnishes the automatic checks necessary to prevent those much dreaded lapses, of which the human element may possibly be guilty.

Where this system is installed, the signal tower consists of a neat and serviceable example of modern railway architecture. It usually contains coal bins, a furnace, lights, a desk, chairs and a clock, all for the use of the operator. It also contains electric batteries, and on a double track line where there are no switches, it contains two block signal instruments, four levers for operating the

signals, two or more electric bells, a telephone, signal flags and other necessary appliances.

For the sake of a clear understanding of this method of signaling let us suppose that we have entered signal tower B, with tower A about a mile to the north, and tower C about the same distance to the south of us. The typical arrangement of the block signals on the New York Central are as follows: A signal bridge which spans the track is placed close to the tower. This bridge carries the two "home"



SIGNAL TOWER No. 40, NEAR "ANTHONY'S NOSE" ON THE HUDSON RIVER, N. Y. C. & H. R. R.R.

takes has been so far reduced, one may say, that in order to bring about a grave error, it would require the collusion of two men, and that only with instruments out of order or with seriously deranged electrical circuits. This is a state of affair which is practically impossible to find on a road where effective discipline and efficient maintenance are the normal conditions.

The object of the controlled manual, like that of all other block signal systems, is to secure the space interval between trains, moving in the same direction on the same track, and in case of failure of the apparatus to work, delay and not disaster will be the result.

The human element, for the most part, provides the power necessary to operate the signals, though in cases where a signal is so placed as to require a very

signals for block B. The "distant" signal for the southbound track is situated perhaps something over 2,500 feet north of the tower, and the "distant" for the northbound track is placed about the same distance south of the tower. All these signals are operated by the signalman in tower B. The "distant" signal for the northbound track, belonging to block C, stands nearly opposite B's southbound "distant." The southbound "distant" for block A is almost opposite B's northbound "distant" signal. In this way the entire right of way is signaled all along.

As the signalman in tower B operates four semaphores, his cabin contains four levers, and as he is between blocks A and C, he has two signal cabinets. These instruments were designed and patented by Mr. J. P. Coleman, of the Union Switch and Signal Company, of Swiss-

vale, Pa., and are models of carefully constructed mechanical and electrical apparatus. The illustration shows each as a cast iron box, with a circular glass at



COLEMAN BLOCK SIGNAL INSTRUMENTS, SHOWING PUSH BUTTONS AND UNLOCKING PLUNGER, N. Y. C. & H. R. R.R.

the top revealing a miniature semaphore with red arm on a white background. A little below this is an oblong opening covered also with glass through which is visible a card displaying appropriate words, designating each operation. At the bottom of the box is a brass knob which is the handle of the plunger.

The operation of signaling a train through block A and consenting to its entrance into block B may be briefly described as follows: Let us say that the signalman at A desires to facilitate the passage of an express which we will call the Southseeker, it is moving along the southbound track and A therefore presses one of his electrical push buttons and gives three rings on the bell for the southbound track in B's tower. This causes B to respond by pulling out the handle of the plunger in his signal instrument on the side of his tower adjacent to A. The pulled out plunger is drawn back by a spring within the mechanism, and the action of the man is transformed by electrical mechanism into the unlocking of

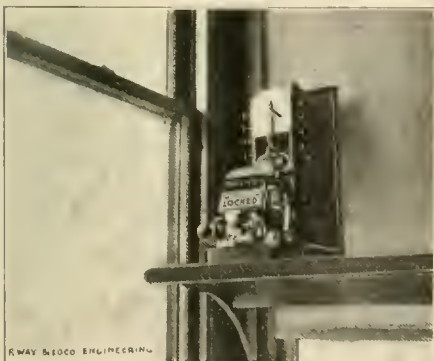

COLEMAN INSTRUMENT WITH CASING REMOVED SHOWING CARD, AND MINIATURE INDICATING SIGNAL.

A's "home" signal lever for the southbound track. That collusion between A and B or mistake upon B's part is impossible, with properly working appar-

atus, is assured by the fact that B could not have pulled out his own plunger for the southbound track unless the integrity of the track circuit had guaranteed the absence of even a pair of wheels in block B, and, furthermore, the plunger could not be pulled out and unlock the signal lever at A unless both B's "home" and "distant" southbound signals were in the horizontal position. It is evident that B can only unlock A's southbound "home" signal lever when his own southbound track is clear. If one may so say, the mechanical accuracy and nicety of adjustment and movement, of electric contact point, circuit breaker latch and lock must be satisfied before B can assist A. It is as if B had to answer to a machine capable of understanding one and only one particular response. It is this feature of the apparatus which prevents an error of judgment or a hasty action from introducing an element of danger. When B unlocks A's lever the action constitutes an absolute guarantee of good faith.

The recoil of B's plunger, after he pulled it out, locks it in place so that it cannot be moved, and at the same time a card appears in the oblong space before B in his southbound cabinet, with the word "Locked" in plain view. This indicates the condition of B's southbound instrument. The man at A responds at once with two bells, indicating that he has found his home lever unlocked and the sounds are intended as a sort of official "thank you" for B's prompt action.

In a moment or two A rings "four bells" in B's tower, which indicates that he, A, has the train in his block and this tells B that A has done his duty in admitting the Southseeker to block A. This is in addition to the fact that B's card had dropped to show "Train in Block" when the Southseeker passed A's "home" signal. Perhaps a white puff of steam in the distance incidentally corroborates A's four bells, and B applies himself to the safe disposal of the oncoming express. B now presses the button in his other signal instrument three times for C to electrically unlock B's southbound "home" signal lever. C does as requested and the

little red semaphore arm behind the circular glass at the top of B's southbound instrument falls to "clear" and B says "thank you" by pressing his bell push twice. Now having his southbound home lever unlocked through the courtesy of C, who knows that there is no train on this track in his block, the signalman in tower B at once pulls down his own southbound "home" signal to "clear," and in doing so mechanically unlocks his own southbound "distant" signal, which he also pulls down. It must always be remembered that the controlled manual is a "normal stop" system, the signals being only lowered for train movement.

As soon as the Southseeker express reaches A's "home" signal the wheels of the train short circuit B's track battery and drop the card in his southbound



INTERIOR OF BLOCK SIGNAL TOWER ON THE NEW YORK CENTRAL RAILROAD, SHOWING SIGNAL LEVERS AND INSTRUMENTS.

instrument so that it shows the words "Train in Block." B now has the express, so to speak, "on his hands." The train rushes on through the "ail clear" block, and flies past tower B at full speed, both enginemen assured of a clear line. The moment the train passed tower B the hitherto short circuited track relay becomes normal again and restores B's instrument so he can unlock A as soon as B's home signal has been put normal and thus allow him to admit another train into the block. The running of the train onto the track circuit at B breaks the current of C's instrument, dropping the card to "Train in Block." At the same time B's card, bearing the words "Train in Block," drops about a quarter of an inch, just enough to partly obscure the words, while he sees the marker

flags of the train flutter from the last car as the Southseeker speeds on.

The next operation is for B to put his levers back to "normal" again. He first puts his "distant" to "caution," and this action mechanically unlocks his "home," which he now raises to the horizontal position, and in so doing, drops his instrument card to "Free," and electrically renders it impossible for himself to "clear" either of his southbound signals unless again unlocked by C, and before C can do that, the track circuit in block C must show that the train has entered block D.

The object of a continuous track circuit or one which runs the whole length of a block, is to guard against the result of a break-in-two. Some installations use a track circuit at the end of each block, perhaps a couple of rails in length and though this arrangement would drop the "Train in Block" to "Free," yet the rear car or cars, if left in the middle of a block by accident, would not prevent the clearing of the signal at the entrance of the block. The signalman's duty is in any case to observe the markers. An "electric slot" may be used with only the first short track circuit in a series of blocks. This is a device carried on the signal post which automatically releases the semaphore arm, allowing it to go to the horizontal position, in case the operator should omit to do so. He is the only

block and proceed to tower B, and so on through each block.

The advantages which are claimed for this system of controlled manual are: First, that the power required to operate the signals is, as a general rule, supplied by non-mechanical means. In other words, a man usually pulls the



TYPICAL SIGNAL BRIDGE ON THE NEW YORK CENTRAL RAILROAD.

signals to "clear" and puts them back to the horizontal position. Second, that two men are compelled to work in concert and, under all the circumstances, the chances of mistakes are materially reduced. Third, that the man who is in the best position to know whether a train has passed out of a block or not,

the train at B's southbound "home" signal would rest upon C's shoulders. Fourth, there is always the knowledge possessed by the men on the engine that any attempt to run past a "home" signal commanding "stop" would be detected and reported by the signalman whose semaphore indication had been disregarded.

There are one or two regulations in force on the New York Central in connection with this system which have absolute safety for their object. Each signalman records in a book, provided for the purpose, the time the signalman in the block next ahead rang four bells, indicating the approach of a train, and a record is also entered of the time it cleared the second block. For example: B records the time A rang four bells, and the time the Southseeker passed out of block B. Thus a continuous record of the train's movement is kept all along the road.

The controlled manual or the lock and block system presents many interesting features and its operation when maintained, as it must be, in thorough working order, gives confidence to the men on the engine and makes for regularity and safety in train operation.

(To be continued).

A man's honest estimate of himself ought to be worth considering. The trouble is most men are not honest

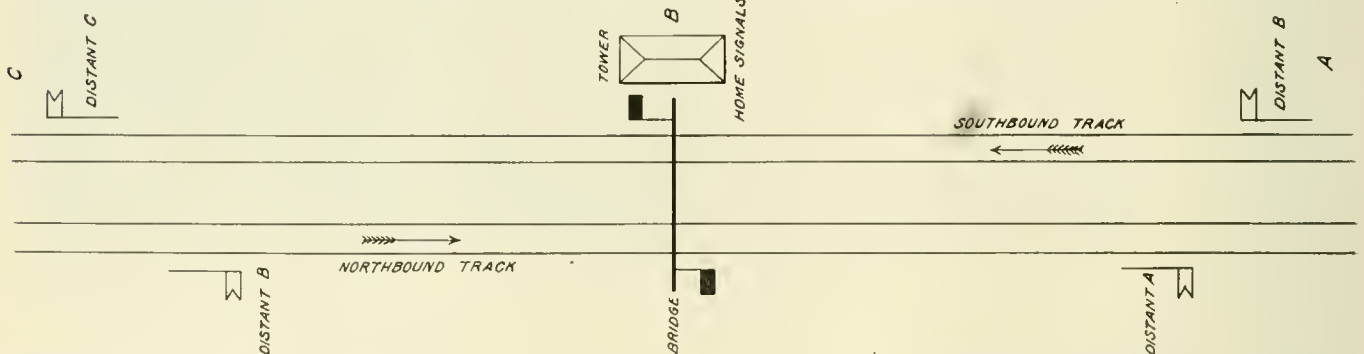

TYPICAL ARRANGEMENT OF TOWER, SIGNAL BRIDGE AND SIGNALS. MANUAL CONTROLLED SYSTEM. N. Y. C. & H. R. R. R.

man with whom such forgetfulness is possible, because, being at one end of a long series, he has no one beyond him who would be interfered with, by his neglect.

The maxim upon which the manual controlled system depends is "the man in advance controls the block in the rear." B controls the southbound track between himself and C, and he governs the northbound track between himself and B.

For example: The train is approaching tower A, and in order to proceed to tower B the signalman at tower A would have to receive an "unlock" from tower B. After receiving the unlock, the signalman at tower A can clear his signals to allow the train to enter the

is the man beyond the end of that block, and he it is, and only he, who can unlock the levers of the block next ahead, and he cannot even do that until the train coming toward him is actually out of his own block.

It would be impossible in the case we have been considering for B to comply with A's request for another "unlock" until the Southseeker is out of block B. If, after the express had passed tower B, the signalman in that tower had left his signals standing at "all clear," he would thus debar himself from operating his plunger on request of A, and if C had left his signals at "all clear" after the passing of the last train, then B would have been unable to clear his signals, and the responsibility for the inevitable stopping of

in judging of their own qualities; if they were there would not be so many misfits. The first step toward reform is to acknowledge the existence of error. If a man is on such good terms with himself that he sees nothing to correct, he is hopelessly lost to all improvement.—*Four-Track News*.

The management of the Baldwin Locomotive Works has donated sufficient funds to furnish, equip and sustain a tent for sufferers from tuberculosis at the health farm controlled by the Denver Young Men's Christian Association. The Pennsylvania Railroad employees recently provided two tents from funds raised among their number employed in Philadelphia.

Of Personal Interest.

Mr. J. Dewey has been appointed acting master mechanic on the Erie Railroad at Galion.

Mr. W. H. Wilson has been appointed master mechanic on the Erie Railroad at Susquehanna, Pa.

Mr. T. J. Cole has been appointed acting master mechanic on the Erie Railroad at Meadville, Pa.

Mr. John G. Witt has resigned his position as general foreman of the Northern Pacific shops at Spokane, Wash.

Mr. T. Rumney has been appointed master mechanic of the New York Division of the Erie Railroad, office at Jersey City, N. J.

Mr. P. L. McManus has been appointed assistant superintendent of the Charlotte Division of the Southern Railway, with office at Charlotte, N. C.

Mr. Ernest H. Bennett has taken the place formerly occupied by the late E. A. Phillips with the National Railway Publication Company of New York.

Mr. W. B. Causey has been appointed general storekeeper of the Chicago Great Western Railway, with office at Oelwein, Ia., vice Mr. D. F. McNab, resigned.

Mr. Harvey Shoemaker, formerly general foreman of the Delaware, Lackawanna & Western, has succeeded Mr. Kilpatrick as master mechanic on the same road.

Mr. Ray D. Lillibridge, the well known New York advertising agent, has returned from a two months' trip to the West. He made a tour of Colorado and the Pacific Coast.

Mr. W. Woollatt, formerly general superintendent of the Lake Erie and Detroit River Railroad, has been appointed superintendent of the Buffalo Division of the Pere Marquette.

Mr. G. W. Creighton, general superintendent of the Pennsylvania Railroad at Altoona, Pa., has received leave of absence owing to impaired health and is recuperating in Arizona.

Mr. Theodore W. Dow has been appointed general air brake inspector of the Erie Railroad, with office at Meadville, Pa. Mr. Dow goes to the Erie from the Canadian Pacific.

Mr. C. W. Graves has been appointed road foreman of engines on the Worcester Division of the New York, New Haven & Hartford Railroad, with headquarters at Providence, R. I.

Mr. W. C. Hayes, formerly assistant superintendent of motive power on the

Erie, has been transferred and is doing special work. His office is now at 21 Cortlandt street, New York.

Mr. I. O. Rhoades has been made general purchasing agent for the San Pedro, Los Angeles & Salt Lake, in addition to the Oregon Short Line. His headquarters are at Salt Lake City, Utah.

Mr. W. S. Haines has been appointed master mechanic of the Jefferson and Wyoming Divisions of the Erie Railroad and of the New York, Susquehanna & Western R. R., with office at Dunmore, Pa.

Mr. C. Graham, formerly division master mechanic of the Philadelphia & Reading at Philadelphia, Pa., has been transferred to Reading, Pa., as master mechanic on the Reading and Lebanon Divisions.

Mr. W. E. Chester has been promoted to the position of general master mechanic of the Central of Georgia Railroad, at Savannah, Ga. Mr. W. H. Fetter succeeds Mr. Chester as master mechanic at Macon, Ga.

Mr. F. N. Hibbits has been appointed consulting mechanical engineer of the Southern Railway System. Mr. Hibbits was formerly assistant superintendent of motive power and machinery of the Union Pacific Railroad.

Mr. George Herren, formerly a freight engineer on the Montana Division of the Great Northern Railroad, has been promoted to the position of general foreman of the company's shops at Glasgow, Montana, on the same road.

Mr. R. F. Kilpatrick has been promoted to the position of superintendent of motive power and equipment of the Delaware, Lackawanna & Western Railroad, with headquarters at Scranton, vice Mr. T. S. Lloyd, resigned.

Mr. W. W. Hurd, formerly a passenger engineer on the Montana Division of the Great Northern Railroad, has recently been appointed to the position of traveling engineer on the same division, vice Mr. J. J. Dowling, promoted.

Mr. W. L. Williamson, heretofore superintendent of terminals at Jacksonville, Fla., on the Southern Railway, has been appointed superintendent of the Jacksonville Division, which includes the line from Savannah to Jacksonville.

Mr. Burton P. Flory, formerly mechanical engineer of the Lehigh Valley Railroad, has been appointed in the same capacity on the Central Railroad of New Jersey, with office at Jersey City, N. J., vice Geo. W. Wildin, resigned.

Mr. Jas. Rollo, who was formerly locomotive foreman at Brandon and latterly foreman on the C. V. Railway, at London, Vt., has been appointed general foreman of the night force at Winnipeg, Man., shops of the Canadian Pacific Railway.

Mr. T. H. Ogden has been appointed to succeed Mr. W. J. Wilcox as master mechanic of the Mexican Central Railroad, with headquarters at Monterey, Mex. Mr. Wilcox takes the place of Mr. T. F. Brady, resigned, at Chihuahua, Mex.

Mr. Henry Hardie has been appointed master mechanic of the Knoxville Branch and Cumberland Valley Division of the Louisville & Nashville Railroad, with headquarters at Corbin, Ky. Mr. Hardie was formerly general foreman of the shops at that place.

Mr. T. G. Ferguson has been appointed assistant locomotive superintendent of the Cordoba & Rosario Railway, with headquarters at Alberdi, vice Mr. E. Thomas, who has accepted the position of locomotive superintendent of the Andine Railway. These railways are in the Argentine Republic.

Mr. Julius Kruttschnitt, it is rumored, will soon give up the position of general manager of the Southern Pacific to become director of transportation of the Harriman lines, which in addition to the Southern Pacific, embrace the Union Pacific, the Oregon Short Line, the Oregon Railroad & Navigation Company and the Leavenworth, Kansas & Western Railway.

Mr. G. P. Altenberg, manager of the Foreign Department of J. A. Fay & Egan Company, the largest manufacturers of woodworking machinery in the world, is on his way to Europe. He will first visit England, and will then tour the Continent. He expects to be abroad several months. Letters will find him, if addressed: Mr. G. P. Altenberg, 31 Boulevard Haussmann, Paris, France.

Mr. Walter Byrd, heretofore general foreman of the Canadian Pacific Railway Company's Winnipeg shops, has been transferred to Calgary, Alta., in the capacity of general foreman of the shops at that point. Mr. Byrd is the inventor of several labor saving devices used in railway shops. The C. P. R. employees at Winnipeg presented Mr. Byrd with an illuminated address and a handsome gold clock on the occasion of his transfer.

Mr. John McGarvey, who has been roadmaster of the Rochester Division of

the Buffalo, Rochester & Pittsburgh Railroad, has been promoted to the superintendency of the Middle Division, between Bradford and Punxsutawney. Mr. McGarvey will succeed Mr. George F. Gardner, and his own place as roadmaster will be filled by Mr. John Fitzgerald, section foreman at Lincoln Park. Mr. McGarvey has been with the company for more than twenty years. He will make his headquarters at Dubois, Pa.

Mr. John R. Slack has been appointed assistant to General Superintendent Stone, of the Delaware & Hudson. He had previously been superintendent of motive power of the road. In his younger days he was a student at Columbia College and later of the Stevens Institute of Technology. He entered on railroad work on the New York Central and rose to be inspector of locomotives and mechanical engineer. In 1899 he left the New York Central to become assistant superintendent of motive power on the D. & H., from which he has risen steadily in the service of the company.

Mr. A. Stewart, general master mechanic of the Southern Railway at Birmingham, Ala., has been advanced to the position of superintendent of motive power succeeding Mr. S. Higgins resigned. Mr. Stewart was born in Illinois, but most of his working life was spent west of the Missouri River. Most of his work was done in the trying school of the Union Pacific Mechanical Department. He came to the Southern Railway a few years ago and made such a good record as a master mechanic that his advancement to the head of the department was the reward of fitness.

Mr. Philetus W. Gates and Mr. Henry W. Hoyt, respectively general superintendent and second vice-president of Allis-Chalmers Company, are about to retire from active participation in the management of that company. Mr. Gates was president and Mr. Hoyt secretary and general manager of Gates Iron Works for fifteen years prior to the incorporation of Allis-Chalmers Company in 1901. They have been prominently connected with the manufacturing interests of Chicago and have taken an active part in all of the manufacturers' associations. The late P. W. Gates, father of Philetus Gates, was the pioneer manufacturer of Chicago and the region west of the Alleghenies, having established his business in 1842. From 1861 to 1871 the Eagle Works Manufacturing Co., of which he was president, employed about one thousand men, and in those days was a noteworthy industry. In 1871 the Eagle Works Manufacturing Co. went out of existence, and from it were organized Gates Iron Works and Fraser & Chalmers, each taking a portion of the

business. Both of these companies in turn were taken over by Allis-Chalmers Company in 1901. Messrs. Hoyt and Gates, after a well earned vacation spent in traveling, will re-engage in business in Chicago.

Mr. Samuel Higgins.

Mr. S. Higgins, mechanical superintendent of the Southern Railway at Washington, D. C., has resigned his position to become general manager of the New York, New Haven & Hartford Railroad. Mr. Higgins is one of the college graduates who donned overalls and learned the machinist trade through a regular apprenticeship, having commenced railroad work as apprentice in one of the Erie Railroad shops in 1881. He rose through the grades of shop foreman, general foreman, assistant engineer, and master mechanic to be assistant superintendent of motive power of the road when he began work. Then he was called away to



MR. SAMUEL HIGGINS.

the higher grade of superintendent of motive power of the Lehigh Valley Railroad, which he left under strong inducements to become superintendent of motive power of the Union Pacific. Although his relations with the management of that great system he left after a few years of hard organizing work, because the Southern Railway Company was determined to have him as mechanical superintendent. His decided success in the important positions occupied commended Mr. Higgins for still higher responsibilities, and no one was surprised to learn that the New York, New Haven & Hartford Railroad had engaged him as general manager. Leading characteristics of Mr. Higgins are quiet, reposeful strength of manner and clear headed executive power. He is still a young man, only 44 years old, and he has an enviable future. We are proud of the latest official given to the operative by the mechanical department.

Mr. H. G. Burt, formerly president of the Union Pacific, has been offered the position of chief consulting engineer of the Trans-Siberian Railway. It was said in many quarters that he had resigned from the Union Pacific to accept the Russian appointment. This is, however, not the case. He resigned in order to travel around the world. It may be, however, that he will be induced to do some special work for the Russian government on the Manchuria and Siberian railways.

Mr. T. S. Lloyd has been appointed general superintendent of motive power of the Chicago, Rock Island & Pacific Railroad, with office at Chicago, Ill., vice Mr. M. K. Barnum, resigned. Mr. Lloyd has filled various important positions on the Union Pacific; Southern; Pittsburgh, Fort Wayne & Chicago; Chesapeake & Ohio and Delaware, Lackawanna & Western. During the recent terrible winter, when the motive power of most North Atlantic roads was prostrated for want of repairs, the engines belonging to the Lackawanna were conspicuous through their regularity in keeping trains moving. Mr. Lloyd naturally was given considerable credit for this pleasant condition of affairs, and several railroad managers were looking in his direction when the Rock Island people secured his services.

Mr. George W. Wildin bid good bye to his many friends on the Central Railroad of New Jersey a day or two before he took up his duties as assistant mechanical superintendent of the Erie. His departure was made an occasion for the expression of the most sincere regret at his loss, and of the best wishes for his future by a thoroughly representative gathering, held in the office of the superintendent of motive power. Among those present were: Mr. W. McIntosh, the S. M. P. of the road; Mr. G. L. Van Dorn, superintendent of the Elizabethport shops; Mr. R. W. Burnett, foreman of the car department; Mr. H. S. Hoskinson, the general storekeeper; Mr. C. E. Chambers, division master mechanic; Mr. H. Montgomery, general foreman of the Jersey City shops; Mr. T. L. Burton, air brake inspector; Mr. H. V. McKedy, chief clerk in the mechanical engineer's office; Mr. G. W. Rink, chief draughtsman; Mr. Wm. Hall, chief air brake inspector; Mr. J. J. Mansfield, chief boiler maker; Mr. H. D. Butler, Mr. G. L. Demarest, Mr. C. Melchinger and Mr. S. F. Hooker, of the office staff; also Mr. P. F. Doyle and Mr. W. Alpaugh, and many other locomotive engineers. Mr. Doyle, who is on the Atlantic City flyer, made a neat little speech, which while overflowing with good humor, yet contained one or two points cleverly worked in, which completely took Mr. Wildin by surprise. Mr. Doyle got

up ostensibly to speak about some trouble they were having with their injectors, and while the retiring mechanical engineer was mentally framing a crushing reply, he found himself in possession of a large bouquet of roses for his wife, with best wishes from all ranks. Before Mr. Wildin had more than been able to realize the drift of things, he was presented with a beautifully made gold emblem of the Mystic Shrine. When this was followed by a few witty sayings from Brother Doyle, and a handsome diamond ring given with every expression of good will and esteem from all present, Mr. Wildin lowered his guard and surrendered, and it was some moments before he was able to say anything in acknowledgment. We have often looked on at presentations, and have seen more or less feeling shown on such occasions, but it is our opinion that if you want to know the right way to conduct a good by ceremony so that no one at it will ever for-

charge of the publishing department of Cook & Sons, the tourist agents. In 1890 he became engaged in publishing the *Journal of Car Heating and Ventilating*, from which in time came the *Railroad Car Journal*, the paper with which Mr. Phillips' name was best known. The "Car Journal" was in 1901 changed to the *Railroad Digest*. Mr. Phillips was a member of the M. C. B. Association, the New York Railroad Club, and the Central Railroad Club. He was also a member of the Masonic order. His genial manner and sterling honesty won for him hosts of friends who now most sincerely mourn his loss.

Tandem Compound 2-8-0 for the Northern Pacific Railway.

The tandem compound shown in our illustration is one of an order given to the American Locomotive Company and built at their Richmond, Va., shops. The

sq. ft.; water tubes 26.76 sq. ft.; fire box 137.33 sq. ft., making a total of 2,593 sq. ft. The grate surface amounts to 46.38 sq. ft. The fire brick arch is supported on four tubes.

The tender frame is made of steel channels. The tank capacity is: water 5,500 U.S. gallons, and coal, 10 tons. The engine presents a neat and trim appearance, its proportions are good and the cab is roomy and comfortable.

A few of the principal figures concerning this engine are:

General Dimensions—Weight in working order, 202,800 lbs.; weight on drivers, 190,400 lbs.; weight engine and tender in working order, 316,800 lbs.; wheel base, driving, 17 ft. 0 in.; wheel base, total, 26 ft. 2 ins.; wheel base, total, engine and tender, 53 ft. 10½ ins.

Cylinders—Size of steam ports, H. P., 2½ ins. and L. P., 2¼ ins. wide; size of exhaust ports, 3 ins. wide; size of bridges, 4 ins. H. P., 2¼ L. P.

Boiler—Thickness of plates in barrel and outside of fire box, ⅝, 1½, ¾ and ¾ ins.; fire box, length, 102⅞ ins.; fire box, width, 65¾ ins.; fire box, depth, front, 71 ins.; back, 55¾ ins.; fire box plates, thickness, sides, ⅝ in.; back, ⅞ in.

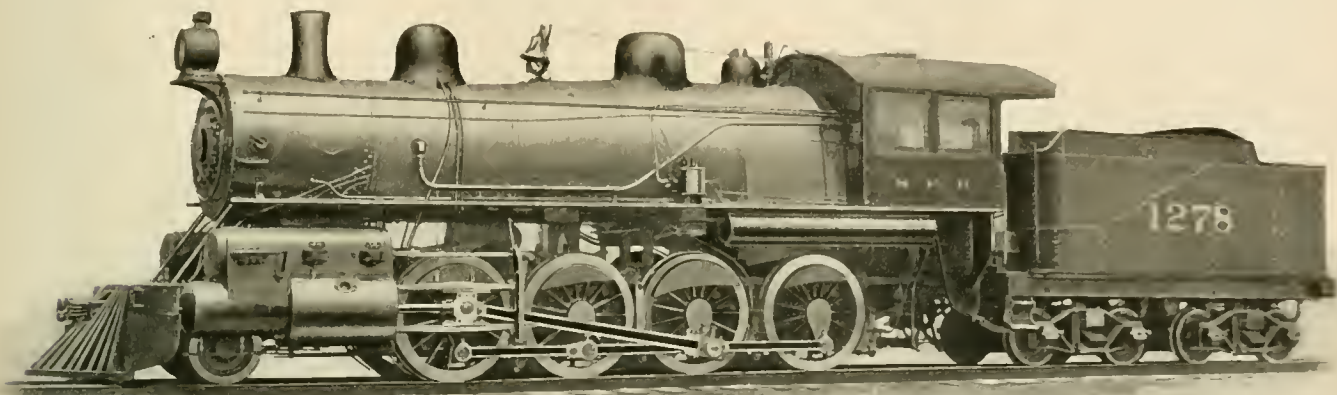

TANDEM COMPOUND FREIGHT LOCOMOTIVE FOR THE NORTHERN PACIFIC.

get it, get the Jersey Central motive power men to tell you about this one.

Obituary.

We are sorry to have to record the death of Edward A. Phillips, general agent of the National Railway Publication Company. His decease took place on February 26, 1904, at the Red Cross Hospital, New York, in the 40th year of his age. He was born in the town of Wolverhampton, England, and was a lineal descendant of Llewellyn, one of the early native rulers of Wales.

In his youth Mr. Phillips was destined for the British navy, and had been prepared to enter as a midshipman, when at the physical examination it was found that he was color blind. His inability to gain admission to the Royal Navy did not prevent his entering the merchant service, in which he remained some years. Prior to his coming to the United States he was connected with the Hull & Barnsley Railway.

On his arrival in New York he took

engines are the property of the Northern Pacific Railway, of which Mr. A. E. Mitchell is superintendent of motive power.

The cylinders are 15 and 28x34 ins. and the driving wheels are 63 ins. in diameter. The engine is of the 2-8-0 type and the weight carried on the drivers is 180,400 lbs. With 200 lbs. pressure the calculated tractive effort of this engine is about 32,300 lbs. and the ratio of tractive effort to adhesive weight is as 1 is to 5.5. The pistons drive on the third pair of large wheels. The leading pair of drivers are the only ones without flanges. The main valves are of the piston type with a travel of 6 ins. and are set with no lead in full gear. They have 7⅞ in. outside lap. The high pressure valves have ¼ in. inside lap, and the low pressure valves have ⅜ in. inside lap.

The boiler is an extension wagon top one with wide fire box. The diameter of the outside ring is 62¼ ins. The heating surface is as follows: tubes 2,428.91

crown, ⅜ in.; tube sheet, ½ in.; fire box, water space, 5 ins., front; 3¼ ins., sides; 3¼ ins., back; fire box, crown staying, radial 1¼ in. dia.; fire box, stay bolts, 1 in. dia.; tubes, number, 311; tubes, length over tube sheets, 15 ft. 0 in.

Tender—Weight, empty, 48,400 lbs.; wheels base, 15 ft., 8 ins.

The Philadelphia & Reading has in contemplation the expenditure of a large sum of money for improvements in the neighborhood of Reading. The company has already expended more than \$4,000,000 for new shops and the Reading Belt Line. Within the past few months several large farms have been purchased by the company in the neighborhood of Monocacy and Sanatoga. A third and fourth track will be added in many sections of the road between Reading and Norristown.

Our friend, the editor of the *Sunset Magazine*, enters a strong protest against the sonorous name San Francisco being vulgarized into 'Frisco. We extend hearty sympathy.

The Lawson Positive Dump Car.

A very interesting car dumping test was recently made in the yards of the Central Railroad of New Jersey, at Communipaw, N. J. The test was conducted in the presence of a number of operating and road department railway officials, the officers of the Lawson Car Company and representatives of RAILWAY AND LOCOMOTIVE ENGINEERING. The party were taken to the Communipaw yard on inspection engine No. 900, by the courtesy of Mr. E. E. Kerwin, division superintendent of that road.

The Lawson dump car, as can be seen from our illustrations consists of a steel underframe upon which rest two oblong boxes. These boxes are 30 ft. long inside, by 4 ft. 7½ ins. wide by 2 ft. 11¾ ins. high. There is a partition in the center of each box for the purpose of stiffening the whole. Each of these dump boxes will hold about 20 tons of material, thus giving the car a total capacity of 40 tons. The car will carry any kind of material from frozen ashes to sticky clay and will dump the same out hard with a surprising degree of facility. The two boxes when in normal position stand back to back on the car, and a hasp on one box caught through a staple on the other, at each end, effectually prevent any movement of the boxes unless intentionally unhasped by the operator.

The outside of each dump box is practically a door, hinged at the top, and it is kept tightly shut at the bottom by a very ingenious device like the finger of a man's hand, which automatically opens when the dump box moves, and holds the door fast when the box is in

race each time a dump box is used. This arrangement diminishes wear and prevents any one set of balls becoming flat. The race casting is hung from the underside of the boxes so that clogging and sticking of the balls is impossible.

The operation of dumping consists

desired angle as the box goes over. When the contents of a box is to be dumped, air is admitted simultaneously to the two air cylinders, and these raise a holding latch and also push the box easily on the ball bearings until it tips and hangs over the side of the car. The shock caused by

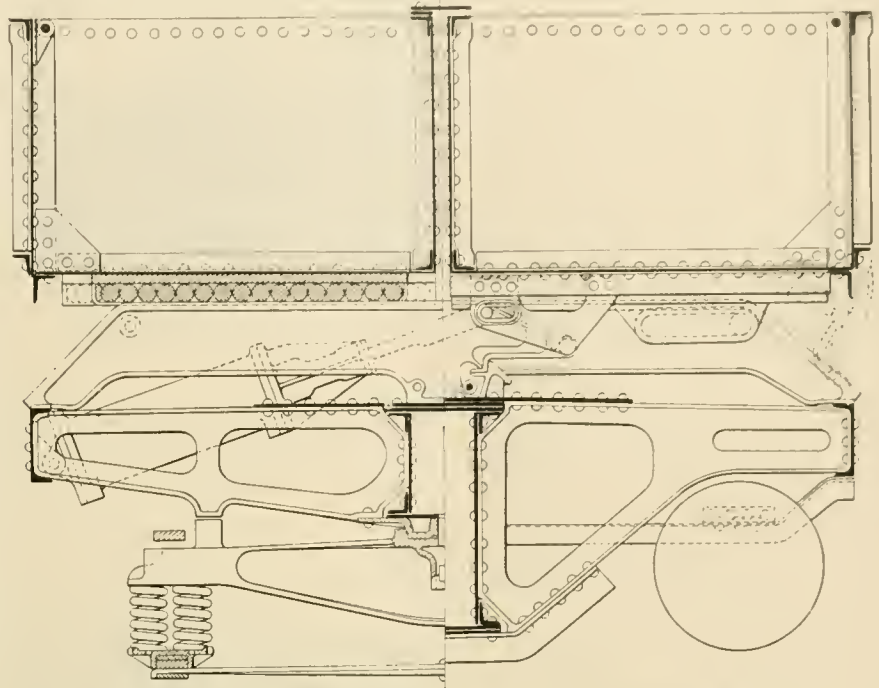

SECTION ON BODY BOLSTER.

SECTION ON CENTER.

in moving the boxes outward in a direction at right angles to the track, and when the boxes come to the end of the bearing rail upon which the steel balls run the boxes tip over at an angle of 45°, with a certain amount of jar, and the load is dumped out completely and

the heavily loaded box falling forward in the act of discharging is taken up by springs placed in the forward end of the air cylinders, against which the piston of each strikes when full stroke is made.

The box is brought back by charging

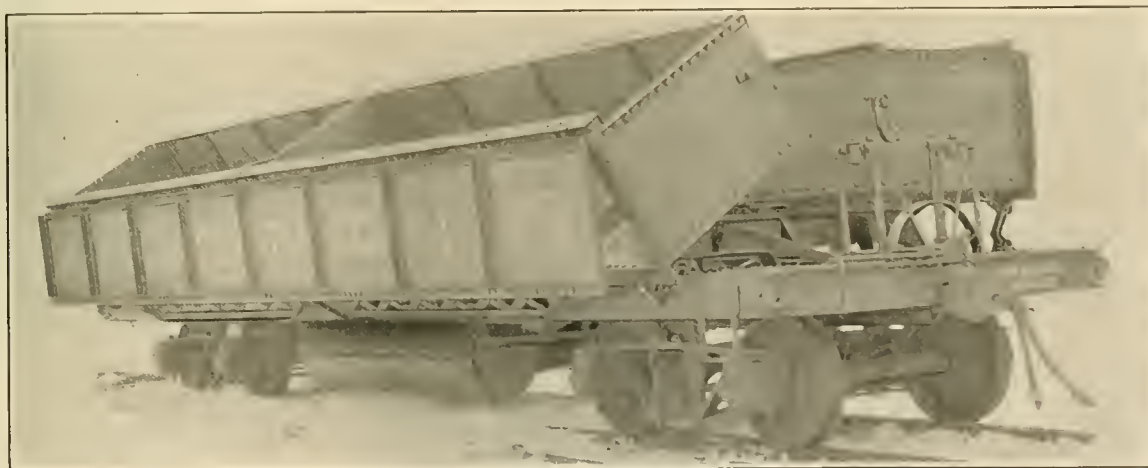

THE LAWSON POSITIVE DUMP CAR.

its normal position on the car. The box is carried on hardened steel balls which run in an oval race. One side of the race only carries the weight, so that the balls which are in service for one dumping, give place to others, thus all the balls move part way round the

at once. The movement of the boxes is effected by compressed air which is drawn from the brake system and is contained in a suitable storage reservoir under the car. There are two 12 in. air cylinders for each box pivoted at their back ends so as to oscillate through the

the air cylinder at the front end, and the boxes are held in place when run fully back by a latch which drops into position, and cannot be raised until the air cylinder again begins the operation of dumping. These latches can all be locked by a hook which is operated by handles

at each end of the car, and which move along a notched sector seen at the end of the car. There are, therefore, the automatic latch, the lock we have just described, and the hasp and staple at each end of the car, all of which securely hold the boxes in place on the car, and prevent any accidental movement of the boxes or any premature or unintentional dumping of the load.

There is on all the Lawson cars the ordinary piping for the air brake, and this train line has a branch pipe which leads to the large storage reservoir under the car which holds the air necessary for the operation of the dumping apparatus. A pressure of 40 pounds per square inch is all that is necessary to dump a load. A stop cock is interposed in the branch pipe which connects the train line with the storage reservoir, and this can be shut when it is not desired to fill the storage reservoir with air. There is also on the branch pipe a check valve which, when the stop cock is open, permits the storage reservoir to fill as well as the auxiliary reservoir, but when brakes are applied the check valve prevents the stored air from entering the train line. The two systems, the brake and the dumping mechanism, are thus always kept separate and one cannot interfere with the other. The storage reservoir can be left charged indefinitely and the load can be dumped as easily with engine disconnected as with engine coupled up. This arrangement is an obvious advantage for construction work, as an engine can place a car or a train and be used at other work, while the whole train can be dumped all at once, or car by car, or only one side with any interval of time between each of the operations.

A test was made at Steelton with side doors made fast, the boxes being turned over to the dumping point, the load did not fall out. The car with this hanging load—an impossible condition in everyday operation—was found to be perfectly stable. The Lawson steel dump car was made at the Middletown Car Works, of Middletown, Pa., and at the test in the Communipaw yard the car maintained its reputation as an instantaneous unloader and positive dump car, which can unload in one spot or distribute a load along the track, on one side of the track or on both, or can be used as a gondola car in regular service and is particularly good for ore, coal or any rough freight which can be loaded by buckets and be unloaded by dumping. The Lawson Boat and Car Company are the owners of the dump car. The personnel of the company is composed of gentlemen prominent in other lines of business and financial enterprise. Mr. David H. Beecher, of Minneapolis, Minn., is the president of this company. Mr. Beecher is also president of a system of

banks in North Dakota, located in nine different cities, with main correspondent in Minneapolis. He is also president of the Beecher Farm Mortgage Company, of Minneapolis, and president of the

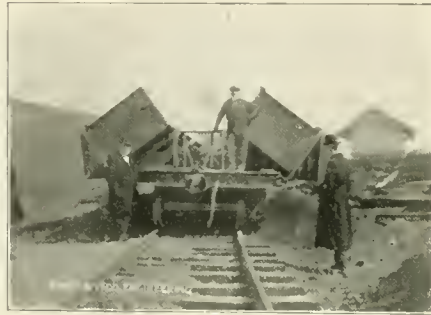

LAWSON DUMP CAR, CAPTAIN LAWSON AT THE LEFT OF THE PICTURE.

Minnesota Central Railway. He is engaged in many other enterprises. Mr. James F. Johnson, president of the Standard Protective Company, is the Lawson Company's vice-president. Mr. Samuel



LAWSON DUMP CAR WITH BOTH BOXES TIPPED OVER.

R. Smith, president of the Bank of Long Island, is its treasurer. Mr. L. H. King, of New York City, is secretary. He is connected with the New York Central Railroad in the executive department.



INSPECTION ENGINE, C. R. R. OF N. J.

The general manager of the company is Captain Thomas Lawson, the inventor of the car, who can always be found in the Wool Exchange Building, 260 West Broadway, New York City.

Pan-American Railway.

About fifteen years ago an agitation arose about the building of a Pan-American Railroad which was a scheme to build a railroad from Hudson Bay snow and ice in the North to similar climatic conditions in Terre del Fuego, the most southern point in South America. The sensible part of the scheme was to build from the existing railroad system of the United States to Buenos Ayres in Argentine, which is in the 35th degree of latitude and more than the distance of one-third of the circumference of the globe from Boston. The project nearly died after a rather robust inception, but it has sprung into new life again. There appears to be some prospect that people may travel by train from Boston to Buenos Ayres within the lifetime of people born. A recent dispatch says:

South America is entering upon a period of more than ordinary activity in railroad construction. The various east and west enterprises now under way will all be feeders for the Pan-American line, and their tendency will be to stimulate its completion. Most of the countries of Central and South America are sharing in this activity. The next few years are quite certain to see the Atlantic and Pacific coasts of Guatemala, Costa Rica and perhaps Nicaragua, united by railroads, a transcontinental road connecting Buenos Ayres with Valparaiso, Bolivia joined by rail to the navigable lower part of the Madeira, and great improvements in Peru's connections with her rich territory east of the Andes. Some of these enterprises are nearly completed, most of the others are beyond the preliminary stages, and all of them will help the Intercontinental road and be benefited by it.

General and Running Repairs.

BY JAMES KENNEDY.

In the interesting discussion on "Slipping With Steam Shut Off," in the March number of RAILWAY AND LOCOMOTIVE ENGINEERING, a "M. C. R. R. Egr," after alluding to the slipshod methods of making repairs on locomotives, closes with the naive observation that he does "not know for a fact that work on hurry up repairs in our roundhouses have been done in this manner."

The writer may keep his mind at rest. This description exactly suits the general method of roundhouse and all other kinds of locomotive repairing. In an experience of over thirty years in locomotive work, I have never seen anything approaching to perfect workmanship in general or special repairs. Shortsighted economy, unreasoning haste, cheap labor, a gradually expanding traffic, a constantly diminishing expenditure per mile of distance

THERE IS A GREAT BROTHERHOOD

of engineers, united in a common high regard for **DIXON'S FLAKE GRAPHITE** — the foremost lubricant of our times.

The troubles of the road, straining cylinders and laboring valves, overheated journals, boiling-hot pins, disturbers of the peace and comfort of every locomotive driver, are all smoothed over by this wonderful graphite.

The easy throw of the lever tells of a bright, smooth-sliding valve and piston; the pins run cool after a long hard grade, the driving boxes never overheat, the air-pump never groans. There is no excessive friction.

Engines stay on the road week after week, month after month; the engineer easily keeps on the inside of his coal and oil allowances; he is known as a good man who knows his business and reaps the reward of good work well done.

The Dixon bond unites a brotherhood of *successful* engineers.

Would you end your lubrication troubles and share this great benefit? Write for Booklet 69-C and a free sample.

**JOSEPH DIXON
CRUCIBLE CO.
Jersey City, N. J.**

traveled, a miserly grudging of a sufficient number of engines to keep pace with the requirements of the road—these causes, together with an overweening ambition on the part of master mechanics and other functionaries to make records for cheapness—in brief, the greedy grasp of soulless corporations that are never satisfied, striving against the naturally increasing cost of maintenance, are the causes that produce the slipshod work so common in locomotive repair shops.

With such forces in a state of perpetual activity and under such conditions, mechanical skill of the best kind is little valued. It is the man who can get the engine out who meets the situation, just as it is the engineer who can get the engine over the road on time who counts. In almost all cases of roundhouse repairing there is necessarily a need of a prompt dispatch of work which can be largely met by intelligent forethought, especially in the preparation and keeping of a liberal supply of the multiplex parts of so vast and varied a machine as the modern locomotive engine.

Original cheap construction has also much to do with slipshod and constant repairing. The cheapest locomotives are cheap only in the beginning. The first time that they come into the shop for general repairs the skilled mechanic can readily point out the loose cylinder studs, the ill fitting braces, the bolts that were never fitted at all, the frames that were never set straight, the joints that were never tight, the binders that never bound anything, the wedges that wobble—but what thanks has he? The engine must be out again. Take up the lost motion and let her go.

Before the engine is stripped, the re-boring of the cylinders has commenced. There is no time to stretch a line through the cylinders to see whether they are parallel with the frames or not. The boring bar is set by the counterbores in the ends of the cylinders as if they were infallible. What rare opportunities I have had of trying a line through cylinders, I have never seen them exactly straight with the frames or even parallel to each other. This deviation from a straight line is not remarkable when it is borne in mind that the saddle, frames and cylinders have had their adjoining surfaces planed on differently constructed machines with tools of varying degrees of flexibility, some machines that were loose jointed and worn with age; sometimes the work being done on upper floors where the vibration was incessant and irregular. Again, in fitting the saddle to the boiler, when this is done, before the frames are attached to the saddle, a slight twist may be given to the saddle to which the slightly flexible

frames will adapt themselves and the mysterious troubles that will end only with the life of the engine has begun.

It is very easy to follow the effect of a cylinder thus deflected from a straight line. Admitting that the guides and crossheads may be set up exactly in line with the cylinders, it will be found that when the main rod is connected to the crosshead, the further end of the rod does not point to the center of the crank pin. This is usually looked upon as a slight inaccuracy in boring out the brasses and a few rubs of a file applied to a certain portion of the inner surfaces of the brasses is deemed sufficient for rectifying this important defect. There is no time to couple the rod to the crank pin and observe the angle at which the rod may be pointing to the wrist pin in the crosshead. It will make a bearing for itself in a day or two.

With this beginning it is not generally considered worth while to make any particular inquiry as to whether the frames are exactly parallel to a line drawn through the cylinders. The pedestals should be perfectly square to each other and carefully finished so that a straight edge can rest on every part of the parallel faces of both pedestals at once. The fitting of the wedges and driving boxes, a matter of vital importance is generally left to mere chance and it is a rare occurrence to see the driving boxes tried in their places before being attached to the axles of the driving wheels.

With such organic defects the way is paved for excessive friction on parts of the guides and crossheads. The pistons keep grinding along some side of the cylinder in a vain attempt to reach a path of less resistance, the shoulders of the crankpins prematurely diminish, the rod brasses rapidly wear away, the pounding that never ends increases in violence until in a short while the loose jointed, ill fitted structure breaks at some point and the scrap pile is back to the shop again.

Repairs of the kind alluded to have the effect of demoralizing and destroying the natural pride that a skilled mechanic ought to take in his work. There is something to be ashamed of in letting work go out of one's hands in this haphazard way. There is a sacrifice of self-respect in being a party to such a system or, rather, to such a lack of system. Sometimes the incongruous spectacle of a special expert is seen taking all the time he wants to set the valves of an engine repaired in this way. Few seem to know that microscopic niceties are an absurdity in connection with such work and at such a time. Nine times out of ten the result is that the valves are away off in

a few days. This is generally a matter of astonishment, although it would be miraculous if the result were otherwise. The erratic paths through which the multitudinous movements have come that finally affect the valves have all been exerting their pernicious influence; and even under better conditions and, were such a thing possible, even with the most painstaking care in general repairs, it would be better if valves were adjusted with precision only after the engine had been running for some days and also while the engine was in its normally heated condition, instead, as is usually the case, when cool and lightened in weight by the absence of water in the boiler.

The subject of general and running repairs of locomotives is so vast that volumes might be written and, indeed, are constantly being written, on the subject. This brief article cannot do other than touch lightly on what is the common method of the beginning and ending of general repairing. The infinite details that go to make up the story of the repairing of locomotives are endless, but it can safely be said that there is, generally speaking, a tendency to give too little time and attention to structural accuracy. There is an encouragement of a blind acceptance of things as they appear to be, rather than the cultivation of a spirit of inquiry to discover what they really are.

A Good Stop Made by a Plucky Man.

A correspondent sends us information concerning the plucky performance of Mr. A. L. Bowsher, engineer of train No. 16, the "Oregon Express," on the Southern Pacific. Mr. Bowsher was in charge of the "head end" of the first section on November 1, last. Just before coming to the high trestle approach to the Sacramento river bridge, near Tehama, he saw that the trestle was on fire. At this point there is a sharp curve to the left, and the approach is through a cutting among trees which obscure the view until one is close on to the bridge.

Seeing the danger when right up to the burning trestle, Bowsher instantly shut off, applied the brakes, in the emergency, and sanded the rails. The engine left the track at the burning portion of the trestle, but, nevertheless, crossed the structure with the plucky engineer still at his post. On the far end of the bridge, the engine was thrown in an almost upright position, the tender and two cars went down, and the fireman, Charles Morris, was killed. The overturned cars caught fire and the contents of the gas tanks under them, added to the fury of the flames. Three cars which stood on the bridge were burned before the engine of the second section could pull the

rear portion of the train to a place of safety.

The rear portion of the train was composed of sleepers, and it was evident to those who saw the wreck that nothing but the unusually good stop made had saved the passengers. Those on board realized the peril from which they had escaped, and at once subscribed among themselves for a suitable acknowledgment to be given to the engineer. Among the passengers was the dramatic organization called the "Florodora Co.," and all united in signing a letter addressed to Southern Pacific officials in which they expressed the hope that Mr. Bowsher would be rewarded by the company for this display of courage.

The passengers and the "Florodora Co.," however, proceeded to practice what they preached. They presented the engineer with a serviceable gold watch and chain, the watch being suitably inscribed, and the "Florodora Co.," in addition, gave him a handsome gold medal "for bravery." Division No. 110 sent letters of thanks to the passengers and to the opera company, acknowledging the kind and generous consideration of a fellow member of the Brotherhood of Locomotive Engineers.

It is highly probable that amid the bright, though unreal flowers in stageland, the ladies of the double sextet were perhaps more in earnest than usual when next they sang "Are there any more at home like you?" and, no doubt, those answering in song were thinking of the sort of men there are to be found on the Southern Pacific, and of Engineer Bowsher in particular, as they replied, "There are a few, sweet maid, and better boys you never knew!"

"Ancient" Winters.

In 401 the Black Sea was entirely frozen over. In 763 not only the Black Sea, but the Straits of Dardanelle, were frozen over, the snow in some places rising 50 ft. high. In 822 the great rivers of Europe, the Danube, the Elbe, etc., were so hard frozen as to bear heavy wagons for a month. In 860 the Adriatic was frozen. In 991 everything was frozen, the crops totally failed and famine and pestilence closed the year. In 1107 most of the travelers in Germany were frozen to death on the roads. In 1134 the Po was frozen from Cremona to the sea, the wine sacks were burst, and the trees split by the action of the frost with immense noise. In 1236 the Danube was frozen to the bottom, and remained long in that state. In 1316 the crops wholly failed in Germany. Wheat, which some years before sold in England at \$1.50 the quarter, rose to \$10. In 1308 the crops failed in Scotland, and such famine ensued

GOLD CAR HEATING AND LIGHTING COMPANY

Catalogues and Circulars Cheerfully Furnished

MAIN OFFICE
FRANKFORT AND CLIFF STREETS
NEW YORK

BRANCH OFFICE
THE ROOKERY
CHICAGO

Manufacturers of ELECTRIC STEAM AND HOT WATER APPARATUS FOR RAILWAY CARS

Are You Prepared?

Don't wait until the day of examination comes, but send immediately for the following books—

Study Them and Your Promotion is Assured.

JUST ISSUED

New York Air Brake Catechism

By Robert Blackall. The only complete treatise on the New York Air Brake and Air Signaling Apparatus, giving a detailed description of all the parts, their operation, troubles, and the methods of locating and remedying the same. Including and fully describing and illustrating the Plain Triple Valve, Quick-Action Triple Valve, Duplex Pumps, Pump Governor, Brake Valves, Retaining Valves, Freight Equipment, Signal Valve, Signal Reducing Valve, and Car Discharge Valve. 250 pages. Price, \$1.25.

Locomotive Catechism

By Robert Grimshaw. 23d Edition. Is right up-to-date and contains twelve large Folding Plates and 1,600 Questions and Answers on How to Run a Locomotive. The Standard Book on the subject, being written in plain language and free from mathematical formulæ and complex problems. Endorsed by all Railroad Journals. Price \$2.00.

15TH EDITION OF

Air Brake Catechism

By Robert H. Blackall. Just issued. Entirely rewritten, revised and enlarged. Contains 1,500 Questions and their Answers on the Westinghouse Air Brake, which are strictly up-to-date. Includes two large Westinghouse Air Brake Educational Charts printed in ten different colors. The latest practical work published. Endorsed and used by all Air Brake Inspectors and Instructors in the United States. Send for a copy and get posted on How to Handle Air Brakes. \$2.00.

Combustion of Coal and the Prevention of Smoke

By Wm. M. Barr. Contains over 800 Questions and their Answers on The Science of Steam Making. Price, \$1.50.

Locomotive Breakdowns and their Remedies

By Geo. L. Fowler. Just issued. Tells how and what to do in case of an accident or breakdown on the road; includes special chapters on Compound Locomotives. Better procure a copy, as it contains 800 questions and their answers on accidents and breakdowns. Price, \$1.50.

These books contain many Questions and their Answers asked by the examiner on your road, so don't put off until examination day comes, but get them now. Send for a special circular describing the books in full. Any book sent prepaid on receipt of price.

Agents Wanted. Write for Particulars.

The Norman W. Henley Publishing Co.
132 Nassau St. New York, U. S. A.

that the poor were reduced to feed on grass, and many perished miserably in the fields. In 1308 the wine distributed to the soldiers was cut with hatchets. The successive winters of 1432-3 4 were uncommonly severe. In 1663 it was excessively cold. Most of the hollies were killed. Coaches drove along the Thames, the ice of which was 11 inches thick. In 1709 occurred very cold weather; the frost penetrated three yards into the ground. In 1726 booths were erected on the Thames. In 1744 and 1745 the strongest ale in England exposed to the air was covered in less than 15 minutes with ice an eighth of an inch thick. In 1808 and again in 1812, the winters were remarkably cold. In 1814 there was a fair on the frozen Thames.

Handy Flue Tester.

Through the courtesy of Mr. J. E. Keegan, master mechanic of the Grand Rapids & Indiana Railway, at Grand Rapids, Mich., we are able to show a

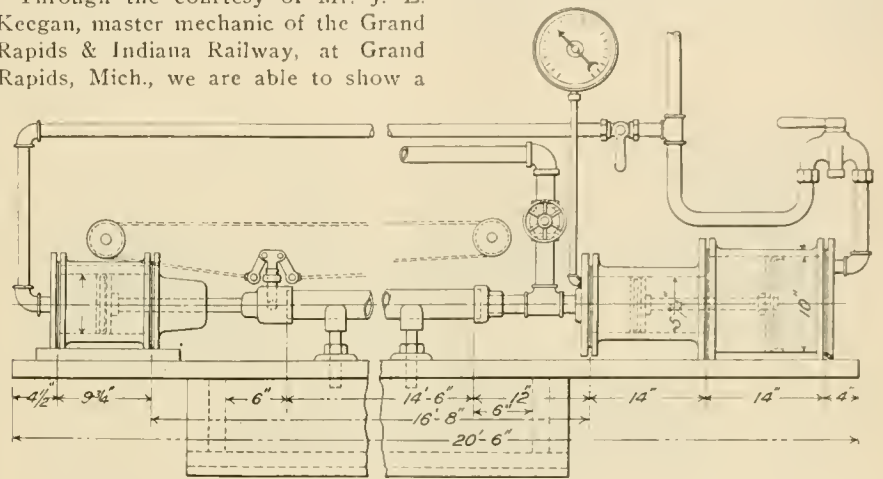

FLUE TESTING APPARATUS.

cheap and very effective flue testing apparatus.

The machine is mounted on a trough to carry away the waste water and at each end of it, firmly secured, are cylinders of various dimensions. The cylinder to the left, whose diameter is 6 ins., has a piston with detachable rods of various lengths to accommodate tubes of various lengths and the caps on these rods are supplied with bleeder cocks, to relieve the pressure after the test has been made. A 1-in. pipe with a cut out cock connects the right and left hand cylinder and a 1 1/2 in. water pipe with a globe valve, connects the small cylinder with the water service line. A gauge is also attached to this cylinder to indicate the pressure applied. After the cut out cock has been opened and air admitted to force the piston rod of the left cylinder snugly against the tube to prevent leakage, sufficient water is turned on to fill both tube and small cylinder to the right. An old style threeway cock is then operated and the air pressure forced

against the piston of greater area. This then moves the smaller one, as both are connected by a rod. The smaller one moves against the imprisoned water and forces up the pressure in the tube. The sizes of the various cylinders which should be used to get the best results are respectively: Left hand cylinder, 6 ins.; small right, 5 3/4 ins., and large right, 10 ins. This device, which is not patented, has saved many an engine failure by detecting defective or poorly welded tubes before application to the boiler.

A Catechism on Lighting.

The Safety Car Heating & Lighting Company, of 160 Broadway, New York, have recently issued a neat little booklet which they have called Directions for Management and Catechism of Steam Heating Apparatus on Trains.

It contains 64 questions and answers, has a stiff cardboard cover and readily fits into a man's waistcoat pocket. It should be in the possession of every railroad employee where the Safety Car Heating & Lighting Company's system is in operation, as it deals with the description of the apparatus, the operation of the apparatus, the care of the apparatus and the responsibility of employees.

This company have also issued a Directory of Pintsch Plants, which gives the town and street address or the man in charge of all the plants where this kind of gas is supplied to railroads. They have also issued a map of the United States showing the locations of the Pintsch plants and the railroads securing the gas in the various States. This last publication is exceedingly well got up. The map shows Pintsch gas establishments at Philadelphia, Pittsburgh, Altoona and Harrisburg, which are four out of seven plants that the company are building to take care of the Pennsylvania Railroad car lighting.

Any of these books can be had by those entitled to receive them by applying to the Safety Car Heating & Lighting Company.

A Handy Shop Trestle.

If you have an opportunity for a stroll through the Reading shops of the Philadelphia & Reading Railroad, ask the master mechanic, Mr. Roger Atkinson, to show you those handy little shop trestles which are used in connection with the operation of fitting up driving boxes in the back shop.

The trestles are, to begin with, made of wood, in the form of a small but substantial horse, and through each end of the wooden top member two pieces of 1 in. pipe are passed so that the pipes stand vertically. These upright pipes are joined together by means of a pair of elbows and a 1 in. nipple of suitable length. The whole of the pipe arrangement makes roughly the shape of an inverted letter U. The pipe arrangement passes through a couple of washers which

other end of the plank for the power end of the lever. This is a lever of the second class, where the weight is between the power and the fulcrum, just as the reverse lever or throttle regulator is on a locomotive.

The pins can be loosely chained to the wooden horses if desired, and the U-shaped pipe arrangement can be made by simply bending a length of pipe, but the elbows provide a little shoulder which prevents the plank from slipping off sideways. These trestles are handy, they are easily made, and are very much liked by the men who use them.

The Baker Hot Water Heaters, non-freezing, is the title of an illustrated catalogue issued by the estate of the late Wm. C. Baker, the inventor and patentee of the heater. The New York office of the concern is at 143 Liberty street. The catalogue contains cuts of each part with name and number, for ordering. The jointless, flexible steel, single coil, fire-proof heater is shown in the front of the

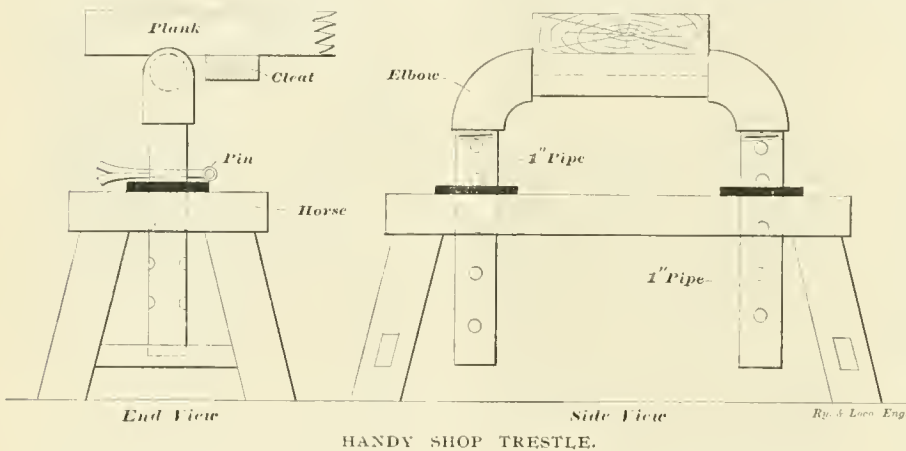

HANDY SHOP TRESTLE.

lie on top of the wooden horse, and the vertical pipes are drilled across at suitable intervals, so that alterations in height can be made by the insertion of a strong pin or split key as shown in our illustration.

When two of these trestles are used together, a plank is placed across the horizontal pipe nipple, and on the underside of this plank, two cleats are spiked. These cleats are placed on the inside between the trestles and prevent the plank sliding off at either end, just as the flanges of a pair of wheels take care of end thrust.

The axle box to be fitted is placed on the plank and when ready is turned on its side, and the plank raised first at one end and then at the other, and the pins put through holes in the vertical pipes, until the box is high enough to slide over the driving journal and be tilted up and rocked on the axle. The raising of the plank with the axle box on the center is not hard, as each end becomes in turn the fulcrum of a lever with the

pamphlet, and the Mighty Miget with list of parts, follows. The operation of the heaters is described, and directions for filling are given. The perfected safety pressure vent is catalogued and the old style with its unreliable features is also set forth. Some useful construction information, relating to piping and fittings is given, and a couple of excellent half tones at the end of the book show the Baker improved house warmer.

The Armstrong Brothers Tool Company, of Chicago, otherwise "the tool holder people," have just issued a little catalogue and price list, which describes and illustrates the various kinds of tools, how they are used, how they are held, and the kind of work they do. Among others may be mentioned the Armstrong boring tool and the Armstrong gang planer tool, the Armstrong offset cutting off tool, and that very useful shop appliance, the Armstrong universal ratchet, which is able to do work in very tight places

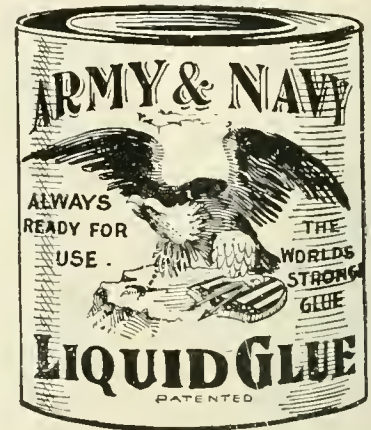

"Throw Away your Glue Pot"

Why have the smell of boiling Glue around you all day, and the waste and expense of boiling dry Glue, when you can for less money use

ARMY & NAVY LIQUID GLUE?

Not a Fish Glue

but a pure hide and sinew glue in liquid form.

The Glue of the 20th Century

will do twenty-five per cent. more work than a fish glue.

No smell. No dirt. Always ready for use.

Let us send you Samples and Prices

WACHTER MFG. CO.
BALTIMORE, MARYLAND

Keep Your Mind On It



CRANDALL'S HELIOS AIR PUMP and THROTTLE VALVE

PACKING

Put Up in Sets
Exact Fit to Rod and Box
Send Trial Order

The Crandall Pkg. Co.
123 Liberty Street
N. Y. CITY
Chicago Office, 30 La Salle St.

because this ratchet will drive a drill in any position where it is possible to move the handle. Write for catalogue if interested.

The Ajax Metal Company of Philadelphia have purchased the business, plant, good will and fixtures of the late Bates Metal Co., of Birmingham, Ala., and will continue the metal business in all its branches under the name and title of The Ajax Metal Company of the South Birmingham, Ala. Ajax, as all students of Greek mythology know, is famous for having defied the lightning. The Ajax Metal people are famous for their successful defying of hot boxes with their bearing metal.

Learn to Set Valves.

Nearly every intelligent man connected with locomotive maintenance or operation desires to understand how to set valves; but very few people have an opportunity to learn how the work is

The Union Switch and Signal Company, of Swissvale, Pa., have issued their illustrated catalogue, Section No. 4, on mechanical interlocking signals. The catalogue is uniform with the previous issues by the company, and is well illustrated and contains prices. Parts are numbered and named for ordering. There are 119 pages in the publication and the subject is covered very thoroughly.

A little pamphlet has been issued by the Pittsburg Crushed Steel Co., Ltd., the manufacturers of steel emery and steelite. The pamphlet sets forth what it is, and tells you what not to do and what to do; what to do with it and what not to do with it, and who uses it. Steel emery is an abrasive; if examined under a magnifying glass it shows a grain of irregular shape but of great hardness, suitable for heavy grinding. Write the company for a copy of the little pamphlet

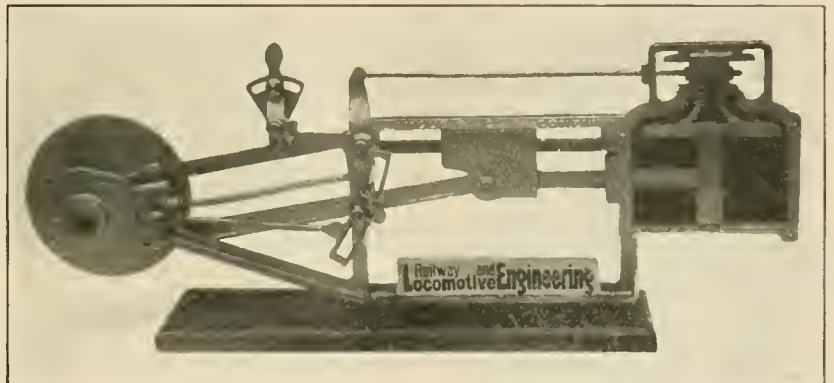

ANGUS SINCLAIR COMPANY'S VALVE MOTION MODEL.

done. By the aid of the valve motion here shown, now handled by the Angus Sinclair Company, any person can learn to set valves just as easily as if he had a real locomotive to experiment with. All the parts that are adjustable in the valve motion or a real engine are adjustable in this model. The eccentrics can be rotated on the shaft to any position, the eccentric rods and the valve stem can be changed in length and the hanger stud of the link being secured to a sliding block, the point of suspension can be changed to adjust the cut-off. That feature and the moveable eccentrics give good opportunity to experiment as to how the valve motion is often out of square. A piston valve can be put in to replace the slide valve when that is desired. It is the best valve motion model ever offered, at a price within the reach of an ordinary engineman or shopman. The model is sent expressage paid for \$15.00 or 25 subscriptions to RAILWAY AND LOCOMOTIVE ENGINEERING, or 15 subscriptions to the *Automobile Magazine*.

if you wish to get some information on this subject.

"It's an Ill Wind," Etc.

Even the appalling fire which recently swept a large part of Baltimore out of existence will benefit some. The salvage companies, who save goods damaged by fire and sell them for the benefit of the fire insurance companies, will profit by this loss. The goods damaged must be carefully dried before they become saleable, much depending upon the success of this drying. The Underwriters' Salvage Company, of New York City, recently placed an order with the B. F. Sturtevant Company, of Boston, Mass., for the complete equipment of a kiln for drying such goods by the Sturtevant fan system. The kiln is divided into small rooms of various widths served by overheads tracks from which are suspended frames for supporting two tiers of baskets for the reception of the water soaked material. These rooms are of

Photographs

of Locomotives from railways all over the globe. The Largest collection on earth. Over 10,000 varieties of Locomotives, cars and trains from American, British, French, German, Italian, etc., etc., railways. Samples 6 x 8 inches, 25 cents; 8 x 10 inches, 36 cents, postage paid.

ILLUSTRATED PRICE LIST FREE

THE LOCOMOTIVE MAGAZINE

Full of railway pictures and information. 6 cents a copy, postage paid.

SEND DIRECT TO

Locomotive Publishing Co., Ltd.

The World's Railway Photographer

3 Amen Corner, Paternoster Row, London, E. C.
New York Agents, The Darry-Collard Co., 256 B'way
London Agent, Railway and Locomotive Engineering

fireproof construction and the size is governed by the material to be dried. Hot air is diffused through the rooms while the amount of air and its temperature is easily controlled. The drying is positive, economical and always independent of the weather. The kiln is not only equipped with the Sturtevant apparatus for drying, consisting of a Sturtevant steam fan connected to a Sturtevant fireproof heater and galvanized iron distributing pipes, but the entire material and workmanship for making the rooms fireproof was furnished by the B. F. Sturtevant Company.

New No. 109 Automatic Band Rip Saw.

If any of our readers have ripping to do, the machine here represented will without doubt prove of considerable interest. The makers claim it will surpass in quality and amount of work any other of this class. It is original in every re-

quickly made, and there is a great saving in time each day in making the various adjustments. It is admirably adapted to reducing large timbers to smaller dimensions, ripping wide lumber into strips of varying widths, resawing from the side of a timber, and other light work.

The straining device, which controls the upper wheel and the path of the saw blade on the face of the wheels, is new and very sensitive, and is covered by letters patent. No matter what the vibrations are the strain takes up the slack in the blade instantly, thus adding wonderfully to the perfect working of the machine, and of lengthening the life of the saw blades. The lower wheel is solid, lessening the circulation of dust and air, and giving itself increased momentum so that its speed governs the upper wheel and prevents it from over-running the lower.

The machine has three feeds, and powerfully driven feed rolls in the table and above the table; and by a single movement of a lever convenient to operator, the machine can be instantly changed to a hand feed rip saw, or instantly stop the feed.

Further particulars can be obtained from the makers, J. A. Fay & Egan Co., of No. 445 West Front street, Cincinnati, O., who will also send their complete catalogue of wood working machinery free to those desiring it, who will write mentioning this paper.

Compendium of Drawing.

The American School of Correspondence at Chicago have issued, in two volumes, their Compendium of Drawing which have been compiled from the instruction papers in the courses of the American School of Correspondence at Armour Institute. The first volume consists of seven of the forty-five regular instruction papers in the architectural course, indexed and bound together in convenient form for ready reference, but the articles are not placed in the order in which they are studied. Following each section are the questions or plates which constitute the regular examination of the school.

The subjects treated of in the first volume are Mechanical Drawing, Shades and Shadows, Perspective Drawing, Pen and Ink Rendering and Architectural Lettering. The second volume takes up Working Drawings, Mechanism, Machine Design, Sheet Metal Pattern Drafting for Tinsmithing, and for Sheet Metal Work. This last volume is composed of five of the forty-four of the regular instruction papers in the mechanical engineering and sheet metal drafting courses.

The books are beautifully printed and a good quality of paper has been used.

THE NEW BARRETT GEARED RATCHET LEVER JACK

30 Tons Lifting
Capacity.

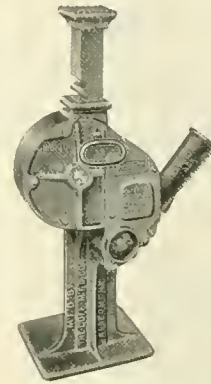

An improved **QUICK-ACTING JACK** for the rapid handling of loaded freight cars, Pullman cars and all heavy loads.

Has the simplicity of an ordinary Lever Jack, the leverage being specially compounded to permit **EASE OF OPERATION** and **QUICK-ACTION**.

No complicated features. Cannot get out of order. Send for Special Bulletin "L" and further information.

MADE EXCLUSIVELY BY

PATENTED.

The Duff Manufacturing Co.,
Works: Allegheny, Pa. PITTSBURG, PA.

BOSTON & MAINE RAILROAD

LOWEST RATES Fast Train Service

BETWEEN

BOSTON and CHICAGO
ST. LOUIS, ST. PAUL

MINNEAPOLIS *and all points*

West, Northwest, Southwest

**Pullman Parlor or Sleeping Cars on all
Through Trains.**

For tickets and information apply at any
principal ticket office of the Company.

D. J. FLANDERS **BOSTON**
Gen'l Pass. & Ticket Agt.

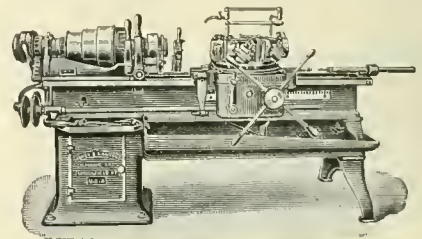

JONES & LAMSON MACHINE CO.

Main Office and Works:

SPRINGFIELD, VERMONT, U. S. A.

A, B, C and Lisber's Code used.

British Office: Jubilee Buildings, 97 Queen Victoria St., London, E. C. France and Spain: Ph. Bonvillain, 6, Rue Blanche, 6, Paris, France. Germany, Belgium, Holland, Switzerland and Austria-Hungary, M. Koyemann Charlottestrasse 112, Dusseldorf, Germany.

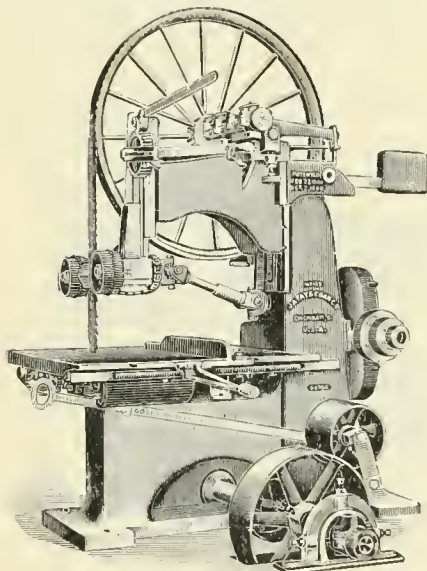

FAY & EGAN BAND RIP SAW No. 109.

spect and has just been built, and is strong in all parts. The makers were the first to introduce a machine of this character and since being placed on the market has proved a revelation to all those who have used it. It was patented February 27, and October 2, 1900.

It presents such an array of improved features that limited space allows of only a few being mentioned, so that circulars should be sent for in order that its full value may be better appreciated.

It is designed especially for heavy work, and is particularly recommended to the car builder and other wood workers who have stock that requires heavy framing.

It is safe to operate, a very small kerf is removed, wide or thick material is easily ripped, little power is required, work always accomplished easily and rapidly, table always at standard height, rolls are close together, allowing short pieces to be fed; adjustment of fences and rolls

H. S. PETERS' BROTHERHOOD OVERALLS

have gone to almost every part of the World where Overalls are worn and are everywhere conceded to be the **BEST**. Every point of material, cut, construction and finish is carefully looked after; the only way that superiority can be attained. Every garment is absolutely guaranteed. The Patented, Fleece-lined, Safety Watch Pocket is alone worth a whole suit of any other make.

I'll send sample suits, charges paid, to any place in the World where mail or express goes, where I have no retail agency; sample materials and full particulars for the asking.

UNION MADE
OF COURSE —
B.L.E. 3—H.S. PETERS—B.L.E. 171
DOVER, NEW JERSEY, U. S. A.



The Twentieth Century Master Mechanic

Won't use solid Mandrels. Cost too much, take up too much room and don't give satisfaction.

Nicholson Expanding Mandrels

Take everything from 1 to 7 inch holes. Take up little room—always ready and you can buy four sets for the cost of one of the solid kind.

Are You Using Them?

Catalogue tells you more about them.

W. H. Nicholson & Co.
Wilkesbarre, Pa.

It is impossible to speak too highly of the illustrations. The line cuts are clear and distinct and the half tones are excellent, and each is placed as nearly as possible to the reading matter which refers to it.

The chief aim of this work, we are told in the preface, is to acquaint the public with the standard, scope and practical value of the papers presented, and in the hope that a study of them will arouse in the reader a desire to know more. The price of the work is \$3.00 per volume or \$5.00 per set, which figures will hold good until June 1 of this year.

Offer of a Good Story for Train Men.

In 1900 "The Run of the Yellow Mail" appeared in the *McClure's Magazine*. At that time, I was General Superintendent of the Pittsburgh division of the Baltimore & Ohio Railroad.

I was struck by the force of the story, it bringing out in an entertaining, as well as an exciting way, the value of resourcefulness on the part of men engaged in the train service.

I then purchased a large number of that issue of *McClure's* and distributed them among the trainmen and engineers of the Pittsburgh division, and since then, I have, from time to time, made up my mind to republish it for our trainmen here, but, from one cause and another, the matter has been delayed until now.

The interest that this story excited among the trainmen on the Pittsburgh division of the Baltimore & Ohio Railroad was of such a character as to give me the impression, very strongly, that a story of this kind, distributed in pamphlet form among the trainmen could not fail to excite in the minds of the trainmen thoughts along lines that would tend to make them resourceful in cases of emergency.

With this object in view, I have published the story for distribution to our trainmen, and the trainmen of roads that use our coal.

I think it would be beneficial to the railway service if this distribution were made general, and therefore, I will be glad to furnish these pamphlets to railroad companies or others, at about the cost of printing and the trouble of handling them, with any advertisement that may be designated, to the railroads of the country.

If, after reading the story, you believe as I believe, that it would be an inspiration to beget greater effort on the part of trainmen, I would be glad if you will give it such notice in your valuable paper as you think the story deserves.

While it is now issued to advertise coal and coke, the product of the company with which I am now connected, I am

really more interested in seeing it widely distributed among the railway men, with out the advertisement of our product.

H. F. MARONEY,
Vice-President

Pittsburg, Shawmut & Northern Railroad.

St. Mary's, Pa.

The B. F. Sturtevant Company, of Boston, Mass., have just got out the second edition of their catalogue, No. 115. It deals with Sturtevant engines, motors, generating sets, forges, steam heating and ventilating and drying apparatus and other products of the company, such as forges, steel pressure blowers, exhausters, counter shafts, blast gates, disk and propeller fans, mechanical draft fans, exhaust heads, steam traps, industrial equipments, etc. The catalogue is illustrated throughout and prices are given. It may be obtained on application to the Sturtevant Company.

The Star Brass Manufacturing Company of Boston, Mass., announce that they have changed their office at Chicago from the Monadnock Building to 303 Fisher Building (phone Harrison 2836). The agent in charge of the Chicago office is Mr. Wm. T. Johnson.

In a neat pamphlet issued by F. W. Bird & Son, East Walpole, Mass., designed to show a few of the "Outward and visible signs" of Paroid Roofing, may be seen illustrations of the U. S. Government Buildings at Havana, Cuba, where 12,000 squares of Paroid were used in 1898, while in 1902 the government ordered, at one time, twenty-two carloads of Paroid for shipment to the Philippines; together with other government buildings at Fort Meyer, Va., Chickamauga Park, Ga., and Pt. Jupiter, Fla., the Delaware & Hudson Railroad shops at Oneonta, N. Y., and the coal sheds of the Michigan Central Railroad, Chicago, Ill., the Boston & Maine Railroad Freight Sheds at Rotterdam Jc., N. Y., as well as manufacturing plants, lumber yards, dwellings, and buildings of every description, and from almost every section of the country, showing the adaptability of Paroid to every case. An eloquent testimonial to its fire resisting qualities may be found in the illustration of L. B. Nauss' Lumber Yard, Gloucester, Mass., where sparks had no effect upon this well known roofing. Deserving of honorable mention, too, are the 1,000 squares of Paroid used on the buildings of a cement plant, Barcelona, Spain, as well as large shipments to Australia, New Zealand and South America.

A very interesting publication is Record of Recent Construction No. 46 of the Baldwin Locomotive Works.

which deals with compressed air locomotives. The book is uniform with the others in this series and is printed in light red ink and is well illustrated throughout. The compressed air engines are worked in mines where the use of power generated by fire would be out of the question. These locomotives are long, low, domeless and smokestackless machines. The storage tanks are capable of withstanding a pressure of 2,000 lbs. and upwards. Many forms of these engines have two storage tanks. Vauclain compound cylinders and piston valves are used with compressed air, as well as simple cylinders and ordinary D-slide valves. A series of statements of cost, of air compressing plant, operating expenses, and fixed charges, are given. The comparative cost of operating by compressed air haulage and of mule haulage is given and a typical record of performance of an air operated locomotive is also presented. The air locomotive made a saving over the best performance of the patient mule. The test was for fifteen days and more than \$9.93 per day was saved by the locomotive. The various classes of machines made, with sizes and capacity, are shown in a series of line engravings at the back of the book and a detachable sheet for supplying the Baldwin Works with the data necessary for an estimate, is to be found next to the back cover.

The Gold Car Heating and Lighting Company announce that their new address is, Whitehall Building, 17 Battery Place, New York City. They also say in a circular recently issued: "We have recently made an arrangement with Mr. Thomas A. Edison and his company, by which agreement we are given the exclusive sale in the United States of the Edison Storage Battery for car lighting purposes. Our railway car heating business has grown to a very large extent, and as we are now about to introduce our system of railway car lighting, we found it necessary to secure more commodious quarters. We have taken a large suite of offices, and have moved both our Chicago branch and our New York office to this building."

Among the recent sales made by the Hicks Locomotive & Car Works, of Chicago, are the following: One 45 ton locomotive to the Wisconsin & Arkansas Lumber Co.; one switch engine to the Pullman Company; one 55 ton engine to the Middle States Construction Co.; a 17x24 in. cylinder locomotive to the James Mullins Coal Co.; one 40 ton locomotive to the Patton & Gibson Co., contractors, and one 65 ton and two 55 ton locomotives and 5 box cars to C.

H. Sharp, contractor. Many other engine sales are also reported.

Among the cars may be mentioned, 10 flat cars for the Des Moines City Railway Co.; 12 dump cars to the Chicago Portland Cement Co.; 10 tank cars to the Hollandale Oil Co.; a flat and 2 box cars to the Tremont Lumber Co.; 4 dump cars and 1 flat to the Western Electric Co.; 4 logging cars for the Northwestern Cooperage & Lumber Co.; 4 barrel cars to the Omaha Cooperage Co., and 10 flat cars and 1 tank car to the Patton & Gibson Co. There have also been sold a box car to the Owen Lumber Co.; 4 flat cars to the Bon Air Coal & Iron Co. Other sales have also been made.

The Westinghouse Electric & Manufacturing Company of Pittsburgh, Pa., have just issued two circulars, Nos. 1077 and 1078, concerning electric motors. The first circular deals with type L motors, direct current series wound. This type of motor is widely used for hoisting or other intermittent service requiring large starting torque. It is enclosed to guard against the entrance of dust or dirt, and is suitable for work in mills, foundries and other manufacturing plants. The second circular gives information about the Westinghouse No. 91, single phase railway motor and car equipment. In general appearance the alternating current series motor does not greatly differ from the standard direct current motor made by this company. Motor No. 91 is wound for a potential of 225 volts and frequency of 25 cycles or less. At normal voltage and full load the armature speed is about 700 revolutions per minute. Both circulars are artistically printed and are well illustrated with good clear half tones. These circulars will be sent to any one interested enough to write to the Westinghouse Electric Company for them.

The Bavarian Government has decided to construct a large number of new locomotives upon the models of the American locomotives introduced by the railways of Bavaria nearly four years ago. During the next two years 40 locomotives are to be replaced by 70 new locomotives, and 5,000,000 marks (\$1,190,000) is to be expended for this purpose. The two locomotive factories in Munich, the large establishment of Maffei, as well as that of Kraus, are to be favored in the distribution of these contracts.

"Who held the pass of Thermopylae against the Persian hosts?" demanded the teacher. The editor's boy at the foot of the class called out: "Father, I guess. He holds a pass on every railroad in the country that runs a passenger train."

Besides **ASHTON** LOCOMOTIVE STEAM GAGES



WE MAKE

Duplex Air Gages
Gage Testers
Blow-off Valves
Chime Steam Whistles
Pop Valves

ALL OF A SUPERIOR QUALITY

Catalogue on Application

The Ashton Valve Company, 271 Franklin Street, Boston, Mass.

**American Locomotive
Sander Company**

13th & Willow Sts., Philadelphia, Pa.

Proprietors and Manufacturers,

LEACH, SHERRBURNE, DEAN,
HOUSTON, "SEE" and CURTIS **SANDERS**

"SLIGO" IRON

The Standard for Eighty Years

for

DUCTILITY and TOUGHNESS

Staybolts

Unexcelled
for **Piston Rods
Crank Pins**

AND DIFFICULT FORGINGS

SLIGO IRON & STEEL CO.

Successor to Phillips, Nimick & Co.

PITTSBURGH, PA.

**The Union
Switch &
Signal Co.**

OF PITTSBURGH, PA.

**GENERAL OFFICES AND WORKS AT
SWISSVALE, PA.**

DISTRICT OFFICES:

**New York: Central Building, 143
Liberty Street.**

Chicago: 1536 Monadnock Building.

St. Louis: Terminal Station.

IF YOU ARE A

BOILER MAKER

OR

SHEET IRON WORKER

and are interested in laying out work, send for my sample blue print.

It contains 20 practical problems in sheet metal work, and fully explains my practical method of teaching the subject. Sent upon receipt of 6c. in stamps.

EDWARD BRADY, Room 217, 38 Park Row, N.Y.C.

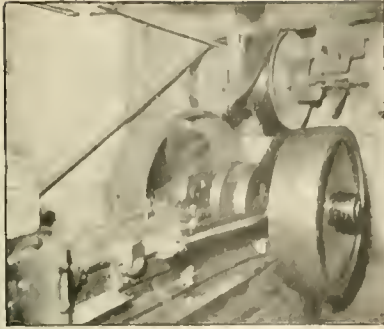

PERFECT BELTS

All belts can be run easy with *Cling-Surface*, do fullest work and not slip. It is a preservative filler for belts, not a surface dressing and not sticky. This belt (Peninsular Tool Co., Detroit) is doing 35 H.P., 180 R.P.M. on 8 ft. centers and is 15 in. slack. Does it easily. Order on trial, test. Pay only if satisfactory.

CLING-SURFACE MFG CO
124-130 Virginia Street
BUFFALO N Y

JUST PUBLISHED
—THE—

LOCOMOTIVE UP TO DATE

The greatest accumulation of new and practical matter ever published treating upon the construction and management of modern locomotives, both

SIMPLE and COMPOUND

By CHAS. McSHANE

Author of "One Thousand Pointers for Machinists and Engineers." Special Exhaustive Articles were prepared for this new book by the
Baldwin Locomotive Works
Rogers Locomotive Company
Schenectady Locomotive Works
Pittsburg Loco. and Car Works
Brooks Locomotive Works
Dickson Locomotive Works
Cooke Loco. and Machine Co.
Richmond Loco. and Machine Co.
With contributions from more than one hundred prominent railway officials and inventors of special railway appliances.
736 Pages, 6x9 inches 380 Illustrations
An Absolute Authority on All Subjects relating to the Locomotive
Bound in Fine Cloth, \$2.50

ONE THOUSAND POINTERS

—FOR—

MACHINISTS and ENGINEERS

By CHAS. McSHANE
(Practical Machinist)

Assisted by CLINTON B. CONGER, Air Brake Expert; J. P. HINE, Mem. Div. 37, B. of L. E.; J. G. A. MEYER, Mechanical Engineer; W. M. F. GOSS, Mechanical Engineer; JNO. C. WHITE, Indicator Expert. The only complete work on the locomotive combining both theory and practice. 342 pages, 187 illustrations.
BOUND IN FINE CLOTH, \$1.50
The only book ever indorsed by the International Association of Machinists. Agents wanted everywhere; write for terms, commissions and club rates. Will be sent prepaid to any address upon receipt of price.

GRIFFIN & WINTERS, Pub.
171 La Salle St., CHICAGO, ILL., U. S. A.

Patents.

GEO. P. WHITTLESEY,

MCGILL BUILDING, WASHINGTON, D. C.

Terms Reasonable. Pamphlet Sent

High Hotel Rates at M. C. B. and M. M. Conventions.

The committee of arrangements for the Master Car Builders and Master Mechanics' Conventions to be held at Saratoga next June, have arranged with the Grand Union Hotel as headquarters, and have agreed on the following schedule of rates:

	Per Day.
Single room, without bath, one person	\$ 4.00
Double room, without bath, two persons	8.00
Double room, without bath, one person	5.00
Extra large double room, without bath, two persons	10.00
Single room, with bath, one person	5.00
Double room, with bath, one person	6.00
Double room, with bath, two persons	10.00
Extra large double room, with bath, two persons	12.00

These rates are outrageously high and are better suited for a convention of rich men than for the members of the railroad mechanical associations.

Several other hotels in Saratoga, which are just as comfortable and give as good service as the Grand Union, are prepared to provide accommodation for lower rates. Congress Hall, which was the association's headquarters at several conventions, offer to receive guests for \$3.00 to \$3.50 per day, and the American-Adelphi, the Worden and others will make similar rates.

The high schedule of rates charged at the convention's headquarters represents the sentiment carefully voiced and cultured, that the conventions must go to Saratoga. We strongly advise members to give practical effect to their objections to the high rates by patronizing other hotels.

In an encyclopedia of Manufacturers of Pennsylvania, published in 1875, Mr. Andrew Carnegie, now the richest man in the world has the following record: "A. Carnegie; a successful railway manager, financier and iron manufacturer, was one of the founders of the company, and with his brother, T. M. Carnegie, treasurer of the Keystone Bridge Company, has been very successful in producing iron especially adapted to bridge work."

In connection with the articles on "The Growth of the Locomotive" which we are publishing, we wish to express obligations to Mr. Andrew J. Fallon, Department of Finance of New York City, for the loan of valuable books and engravings. Mr. Fallon is an old time railroader and retains a keen interest in everything pertaining to the locomotive.

The Monarch Coupler Company, Ltd., of Detroit, Mich., announce that they have secured the Thornburgh patents for draft riggins and will continue the manufacture and sale of them.

Herbert Spencer, the famous writer and philosopher, made provisions in his last will and testament to oppose the introduction of the metric system of measurements into Great Britain. He had very positive beliefs that the forcible introduction of the system would injure British industrial interests. The manufacturing interests of Great Britain and of America are so great that any attempt to enforce a new system of weights and measures would promptly bring its own remedy.

When our eminent friend M. A. Forney finished his apprenticeship to the machinist trade in Baltimore he felt as many other young men do when they graduate, well satisfied with himself and inclined to believe that his services would be greatly in demand. Thinking it would be best to carefully select the line of employment most likely to lead to fame and fortune he asked a friend of the family what position he had better take. He was deeply disgusted on being told to take whatever position he could get.

A locomotive does not lend itself well as a subject to be decorated with flowers. The sentiment of making such decorations is to be admired, but it violates artistic taste. An automobile decorated with flowers seems even less natural than a locomotive loaded down by those excrescences.

Mr. Henry R. Dalton, Jr., was elected president of the Baush Machine Tool Co., to take the place of W. H. Baush, resigned. Mr. C. J. Wetzel was elected treasurer, which took effect on March 21, 1904, to fill vacancy caused by resignation of Mr. David Hunt, Jr. All communications should be addressed to Baush Machine Tool Co., Springfield, Mass.

On March 1, 1904, the Cincinnati office of the Galena-Signal Oil Company was removed to suite 115 Ingalls Building, Fourth and Vine streets, Cincinnati, where the officials of the company will be pleased to have their friends call.

When they first began building railways in British India the most violent opposition was encountered from part of the native population who believed that the bridging of the sacred Ganges river would bring great calamities to the country.

As a substitute for oil upon oil stones, which often thickens and makes the stones dirty, a mixture of glycerine and alcohol can be used with good results.

The Middletown, Pa., Car Works have recently shipped 2,000 iron fence posts to Cuba.

Ball's Official R. R. Standard Watches

16 AND 18 SIZE.



17 AND 21 RUBY
JEWELS,
SAPPHIRE PALLETS

BALL'S IMPROVED
SAFETY
DOUBLE ROLLER

Are without question the finest watches that American talent and skilled labor can produce, and they are giving such universal satisfaction that we have no hesitancy in claiming that they are the best and safest railroad watch on the market.

Tests severe and numerous have proven this fact to the most critical users in all sections of the country, to which thousands of good Railroad and Brotherhood men are ready to certify.

We have an authorized agent in nearly every railroad center. Call on him for information and facts. Write us for descriptive matter.

The Webb C. Ball Watch Co.

Watch Manufacturera

Ball Building, Cleveland, Ohio, U. S. A.

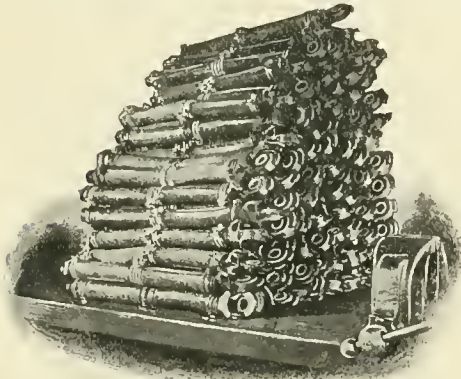

FINISHED WORK

Above cut shows finished work of

HOSE REPAIR OUTFIT

This outfit will do anything in the way of repairing **Steam, Signal or Air Brake Hose**, strip, cut, splice and fit up. Also fits up new hose.

Will pay for itself on most any railroad in a year and many times over on some roads.

Shall we tell you more about it?

BUKER & CARR MFG. Co.

Office, Fairview Heights, No. 19
ROCHESTER, N. Y., U. S. A.

Correcting Errors in Counterbalance.

The form shown here is the standard form used on the Illinois Central and shows their method of detecting defective counterbalancing on all engines passing through the Burnside shops:

ILLINOIS CENTRAL RAILROAD COMPANY.

REPORT OF THE COUNTER BALANCE IN ENGINE NO. 901.

Burnside Shops, Chicago, Feb. 1, 1904.

Right Main Wheel—Weight of back end of main rod, 214 lbs.; weight of front end of side rod, 139; proportion of reciprocating parts, figured at $66\frac{2}{3}\%$, 209; total weight to be balanced, 562.

Right Back Wheel—Weight of back end of side rod, 136 lbs.; proportion of reciprocating parts, figured at $66\frac{2}{3}\%$, 209; total weight to be balanced, 345.

Left Main Wheel—Weight of back end of main rod, 217 lbs.; weight of front end of side rod, 142; proportion of reciprocating parts, figured at $66\frac{2}{3}\%$, 201; total weight to be balanced, 560.

Left Back Wheel—Weight of back end of side rod, 136 lbs.; proportion of reciprocating parts, figured at $66\frac{2}{3}\%$, 201; total weight to be balanced, 337.

CONDITIONS BEFORE RE-BALANCING, AND THE CORRECTION.

R. M. Wheel—Present counter balance weight at crank pin, 645 lbs; correct counter balance weight at crank pin, 562; present counter balance *light* at crank pin, —; present counter balance *heavy* at crank pin, 83; center of gravity, 20".

R. B. Wheel—Present counter balance weight at crank pin, 630 lbs.; correct counter balance weight at crank pin, 345; present counter balance *light* at crank pin, —; present counter balance *heavy* at crank pin, 285.

L. M. Wheel—Present counter balance weight at crank pin, 622 lbs.; correct counter balance weight at crank pin, 560; present counter balance *light* at crank pin, —; present counter balance *heavy* at crank pin, 62; center of gravity, 20".

L. B. Wheel—Present counter balance weight at crank pin, 610 lbs.; correct counter balance weight at crank pin, 337; present counter balance *light* at crank pin, —; present counter balance *heavy* at crank pin, 273.

Useful Numbers.

$3.1415926 =$ ratio of diameter to circumference of circle.

$.7854 =$ ratio of area of circle to square of its diameter.

33,000 minute foot pounds = 1 h.p.

396,000 minute inch pounds = 1 h.p.

396,000 cubic inches piston displacement per minute of engine wheel would develop 1 h.p. with 1 lb. mean effective pressure on the piston.

23,760,000 cubic inches piston displacement per hour of engine developing 1 h.p. with 1 lb. mean effective pressure on the piston.

Steel for locomotive fire boxes began to come into favor about 1875. It made its way slowly and several attempts were made to return to iron or use copper but steel advanced steadily into favor. The excellent mill steel made by the Otis Steel Co. did much to bring about the revolution.

The world always honors him who makes an idea fertile rather than the originator of the idea.

THE ROBERT W. HUNT & CO.

Bureau of Inspection, Tests and Consultation,
1137 THE ROOKERY, CHICAGO.

66 Broadway, New York. Park Building, Pittsburgh
31 Norfolk House, London, Eng.

Inspection of Steel Rails, Splice Bars, Railroad Cars, Wheels, Axles, etc. CHEMICAL LABORATORY—Analysis of Ores, Iron, Steel, Oils, Water, etc. PHYSICAL LABORATORY—Test of Metals, Drop and Pulling Test of Couplers, Draw Bars, etc.

Efficiency Tests of Boilers, Engines and Locomotives.

The McCORD BOX

KEEPS OUT THE DUST.



SEE HOW THE LID FITS.

McCord & Company,

CHICAGO

NEW YORK

CONTENTS.

	PAGE.
Accident, Comparison of Statistics Great Britain and the United States.....	165
Air Brake Department.....	169
*Adjuster, Hints on Care of Automatic.....	169
*Appliance, Recharging and Retaining.....	170
*Street Cars, Air Brakes on.....	171
*Axles, Cracked.....	160
*Boiler Head, First Gauge Stand.....	157
Boilers, Designing Locomotive, by Roger Atkinson	161
Book Reviews.....	167
*Car, Lawson Positive Dump.....	185
Correspondence	157
Driver Brakes Should not be Used with Engine Reversed.....	164
Editorials	164
*Gauge Stand, First.....	157
Improvements, Pennsylvania R. R., in New York City.....	156
Inventor, the Poor.....	166
Link Motion, Real Inventor of, 167;* Reflects on	158
Locomotive:	
Failures of.....	164
*Growth of the, by Angus Sinclair.....	174
Slipping Shut Off.....	160
*Locomotives:	
Rogers Ten-Wheel for N. C. & St. L.....	150
Lancashire & Yorkshire Tank.....	151
2-4-2, for the Austrian State Ry.....	153
"Birkinhead," on Carillon & Greenville.....	154
Ten-Coupled Prussian Tank.....	155
Consolidation for the Erie.....	163
Northern Pacific 2-8-0.....	183
Baldwin 4-6-2 for the Union Pacific.....	184
Memory, Aid to, Concerning Meeting Points.....	161
Personals	181
Questions Answered.....	167
Repairs, General and Running, by Jas. Kennedy	186
Reversing Engine Should not be Done with Brakes Applied.....	164
Rogers Oil Box Packing.....	184
Schools, Russian Railway.....	155
Shop Appliance, Plate Rack Ideas.....	155
*Flue Tester	159
*Signals and Signaling, by Geo. S. Hodgins.....	178
Spark Arrester, German.....	162
Stories and Narratives,	
Stop, Good, Made by a Plucky Man.....	188
Reminiscence of the Early Sixties, by Shandy Maguire.....	151

Railway and Locomotive Engineering

Copyright by Angus Sinclair Co.—1904

A Practical Journal of Railway Motive Power and Rolling Stock

Vol. XVII.

174 Broadway, New York, May, 1904

No. 5

The Unexpected That So Often Happens.

After devoting years of study and experimenting with locomotive draft appliances Prof. Goss of Purdue University had to confess that he could not understand why locomotives could steam freely

which are perfectly familiar to mechanics of one class are totally unintelligible to the workman in another branch. Men who have worked a lifetime in fashioning cast iron under the lathe are greatly surprised on learning that the same material, when employed in the heating

by compressing them in the water cylinder of a hydraulic press. In this operation a mandrel somewhat smaller than the piston rod is put inside, and with all the pressure we can bring to bear, we have never been able to compress the bush so as to grasp the mandrel tight,



SCENE ON EUREKA & KLAMATH RIVER RAILROAD, CALIFORNIA.
(Bridge 500 feet long, 110 feet high, contains 500,000 feet of timber.)

Photograph received from W. C. Chapman

with a wide opening in the bottom of the smoke box which is a common practice with some railroads.

Savants often meet with unexplainable things in their researches. It is the experience of most investigators to find things happening which are entirely unexpected and defy explanation.

In one of his addresses that man of wonderfully keen habits of observation Prof. Sweet said: "Every day things

pipes of a blast furnace stove, grows from six inches to a foot in length from constant use. And the furnace man is equally unprepared to hear that the core bars used for casting pipes lose as much as 3 inches in casting twenty or thirty pieces.

In practice, for instance, we use a piston rod packing of easy fitting babbit bushing. When these bushes become sufficiently worn to leak, we close them up

and yet occasionally we have had these bushes shut down while the engine was running so as to grasp the piston rod as if gripped in a vise, to break the bushes asunder, indeed, or to make this necessary in order to get them off.

Again, in the foundation of embossed work, two dies are used, the female die often being made by driving the hardened male die into a block of soft steel. This operation is easily performed by a

few blows of the drop hammer. It drives in and raises the soft metal without distorting the block in any other particular. Had the same operation been attempted by means of the hydraulic press, the block would probably be upset one-fourth its depth, the sides bulging out or the piece crushed, without producing other than a faint marking of the outline of the male die.

When the lawn mower was first introduced, the inventor was considered little short of a mechanical heretic to imagine that he could get sufficient traction with two light wheels to rotate a cylinder six times their own weight at six times their velocity, and cut the grass in addition. The worm that drives the bed of a Sellers planer does not wear out half as fast as it should, and there is possibly something unexpected about it, even to the makers themselves.

A 12x18 in. cylinder engine, which had been running a year at 185 revolutions per minute on an unusually solid foundation, began one day without apparent cause to shake endwise, and before night had shaken itself loose. As no harm resulted and the work was pressing, the repairing of the foundation was postponed until vacation time, about a month distant. Before that time arrived, however, the shaking ceased, and the engine ran perfectly smooth in spite of the impaired foundation.

Another and even more curious instance of the unexpected was that of a well known electrician who built and tested for three years a certain piece of apparatus, which promised to be extensively used. As it worked perfectly, a large amount of capital was put into buildings and plant for the production of these pieces of apparatus for the market, and many were built, but the manufacturers were totally unable to reproduce the original either in effect or durability.

In another case, two similar boilers were connected by necks at top and bottom, and a fire built under each of them, the boilers being about half full. The water, without apparent cause, behaved very strangely, all going into one boiler and then into the other. When the play was at its height, the boss, considering the lives of the men and the premises of more value than the cause of science, ordered the fires drawn, and the cause could never be determined.

These instances have been taken from practical life, but experience seems to show that scientists are equally liable to be puzzled in just the same way. It is said that Crookes invented the radiometer, and then made it, but to his surprise the action of the instrument was the reverse of what he had anticipated. We might also add the well known case of the Thomson-Houston arc lamp, which is the-worst in theory as it is among the best in practice of all the lamps in the

market. Even its inventors are unable to give an entirely satisfactory explanation of the action of its mechanism.

Handy Shop Kinks.

With all the new shop tools installed in the various railway shops throughout this continent there are still many opportunities offered to improve local conditions and reduce the cost of output. We illustrate here two very handy

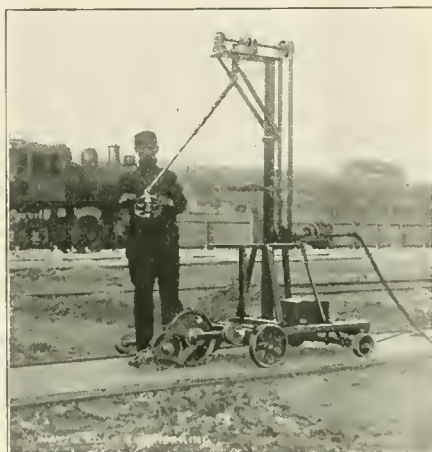

FIG. 1—PORTABLE GRINDER.

tools in use on the Lehigh Valley Railroad which are giving excellent results.

Figs. 1 and 2 are handy tools used in the Wilkes Barre shops. Fig. 1 is a portable machine used for grinding purposes. It is constructed out of gas pipe and has a telescoping feature with toggle connections which permits it to be used at any angle. Mounted on a truck, it is easily moved to any part of the shop. The motive power for

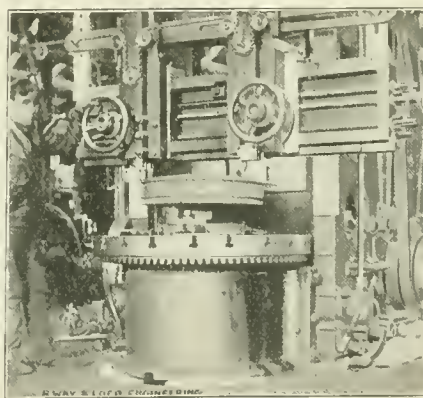

FIG. 2—ATTACHMENT TO BORING MILL.

these three machines is compressed air, supplied to an ordinary air motor.

Fig. 2 shows an attachment to a boring mill and consists of two posts and a cross rail. One of the posts shows holes drilled through it and spaced, the other has a slotted hole its entire length similar to the cross rail which permits it to set the boring tool at any angle. Our illustration shows a Van-

claim low pressure piston mounted on a mandrel with the machine taking a taper cut on the face and cutting the grooves for the steam rings in one operation.

Bad Order Cars.

"When there is almost a blockade in a freight yard then is the time when the bad order cars increase." Thus in effect spoke Mr. W. A. Parker, the Minneapolis M. C. B. of the Chicago, Milwaukee & St. Paul Railway, in a paper recently read before the North-West Railroad Club. One reason for this the speaker pointed out was the rough way cars are switched at certain seasons when business is rushing.

Mr. Parker advocated the location of light repair yards, convenient to yards where trains are broken and made up. Light repair tracks should be 13, and 20 ft. centers. Running down each of the 20 foot centers, a standard track should be placed for the handling of wheels and the hauling of material on push cars. These repair tracks should be stub at one end and not over 800 feet long. It is even preferable to have more tracks and not so long. This arrangement would permit the concentration of the repair force and the light repair cars on tracks which can be easily pulled as occasion requires.

After detailing the required equipment of such a yard, with platforms for heavy castings, air brake testing and repairing plant and wheel storage, the speaker said that about midway in the yard transversely to the tracks a planked roadway 12 feet wide, should always be kept open. It is surprising the large amount of work that can be turned out of a yard arranged in this manner.

Heavy repair yards should be located convenient to shop mill, store room, and blacksmith shop, with tracks similarly arranged to those in the light repair yard, but the spacing should be 15 and 22 foot centers and the tracks should be 1,000 feet long.

An interesting and instructive table derived from a careful checking of inspectors' records showed that broken end posts was a defect which affected 12 per cent. of all the cars set out. Broken timber bolts claimed 10 per cent; broken and missing side doors, 10 per cent.; broken and missing grain doors, 10 per cent; broken draw timbers, 7 per cent.; broken and missing end doors, 5 per cent.; worn and defective wheels, 4 per cent.; broken pocket rivets, 4 per cent. of all cars set out.

Mr. Parker asks what can be done to improve conditions so that cars will not become bad order, and he answered his own question by saying that rough handling in switching should be discouraged, and better inspection should be given to couplers so that they will couple upon

first impact, as not coupling, readily brings about rough handling. We are told that there has been a great improvement by strengthening the draw gear, and that western cars are in better condition in this respect than eastern cars.

We agree with what Mr. Parker says, but in the light of 12 per cent. of the

A Michigan Central 4-4-2.

Our illustration shows an Atlantic type passenger engine built at Schenectady by the American Locomotive Company for the Michigan Central Railroad. Mr. J. F. Deems is general superintendent of motive power rolling stock and machinery for this and the other Vander-

design to that used on this passenger engine. It serves to show the inside admission valve, the general position of the transmission bar and the rocker with hanging arms. The position of the centers of eccentrics are roughly indicated by the lines which, in this instance are inclined toward the front of the engine, with crank pin on the forward quarter and piston close to the front cylinder cover. This valve may be spoken of as an "inside direct" valve and the position of the center lines of the eccentrics may be said to inclose the crank pin, as shown in the sketch. The valves on this 4-4-2 engine are set line and line in full gear back and front and have not less than $\frac{3}{4}$ in. lead at 6 in. cut-off.

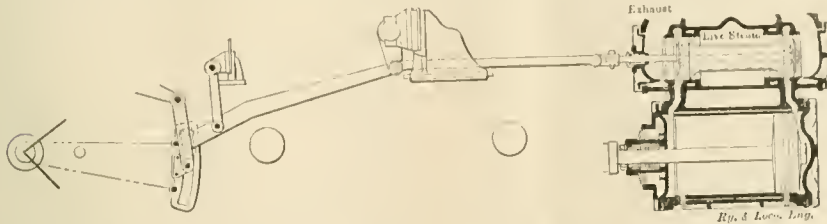

EXAMPLE OF DIRECT MOTION, INSIDE ADMISSION PISTON VALVE.

repairs being due to end posts broken largely caused by load shifting, 10 per cent. for timber bolts broken we think that merely "discouraging" rough handling is too easy a course to pursue. It is not too high an estimate to say that fully one-quarter of the bad order cars are made so by rough switching, and we

built roads and Mr. E. D. Bronner is the superintendent of motive power of the M. C. R. R.

The cylinders of this engine are simple and are 21x26 ins. and the driving wheels are 79 ins. in diameter. The driving wheels have a weight of 95,000 lbs. concentrated upon them. The

The spring gear is overhung throughout and the drivers and the carrying wheels at the back being all connected. There is a traction increaser used with these engines by which weight may be transferred from the engine truck and from the carrying wheels and

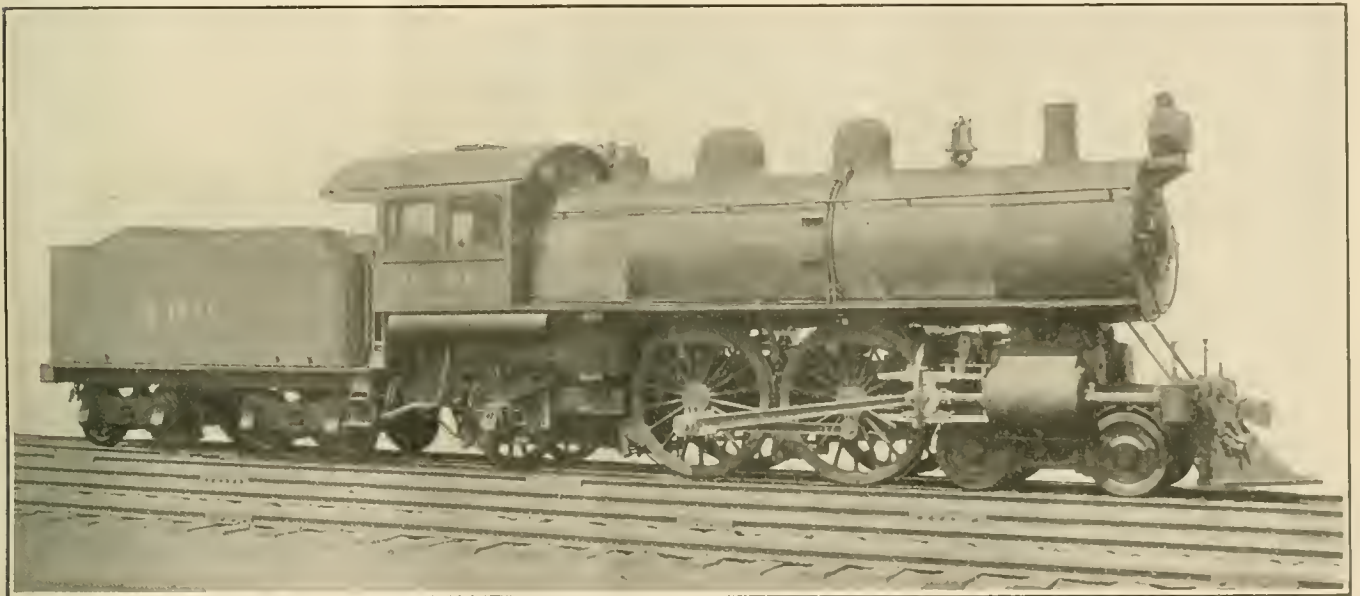

ATLANTIC TYPE ENGINE FOR THE MICHIGAN CENTRAL.

do not believe there is one road in the whole of the United States or Canada which has made any determined effort to stop the abuse. The treatment which 25 per cent. of the cars get in a yard is equal to what the M. C. B. code calls unfair usage, and if a railway company gives that kind of treatment to its neighbors' cars the company is compelled to pay for the damage. The result of rough switching is not fairly a maintenance charge and it ought not be borne by the motive power department. It is an operating department charge, fair and square, and ought to be "put up to" that department as an inducement to exercise some sort of disciplinary supervision over the railroad "car puncher" and "car buster" in terminal yards,

weight of the engine in full working order is about 176,000 lbs. The steam pressure is 200 lbs., and on the master mechanic's assumption that the mean effective pressure at starting is 85 per cent. of the boiler pressure, the calculated tractive power for a slow start on good rail is about 24,600 lbs.

The valves are of the piston type with inside steam admission and the motion is direct. The transmission bar passes with a slight curve over the forward driving axle and reaches a rocker, both arms of which hang down. A sketch of such a form of direct valve motion as is here described is shown in our line engraving. This sketch is taken from a Lake Shore engine of the 2-8-0 type but the valve motion is similar in

put upon the drivers. This is used in making a start with a heavy train or in grade climbing. The crosshead is of the two guide bar type often spoken of as an "allegator" crosshead. In this case the top guide bar has its two lower corners cut out and the upper face of the crosshead lipped up against the notch so that sides of cross head and guide are flush. The axle boxes of the carrying wheels are outside of the frame and the boxes are water cooled.

The boiler is a straight top one with what may be called a semiwide fire box; that is, it extends out over the frames, but is not as wide as the Wootten or hard coal fire box. The diameter of the boiler is 70 $\frac{3}{8}$ ins. inside measure at the smoke box end. The

crown sheet and the roof sheet are both level, the back sheet slopes inward about 15 ins. from perpendicular. The heating surface is: Tubes, 3,314.75 sq. ft.; fire box, 180 sq. ft.; water tubes for brick arch, 27.09 sq. ft., making a total of 3,521.84 sq. ft.

The tender frame is made of 10 in. steel channels and the tank has a water capacity of 5,100 U. S. gallons and a coal capacity of 8 tons. The weight of engine and tender in working order is about 280,000 lbs. The whole machine presents a neat and trim appearance.

Some of the principal dimensions are as follows:

General Dimensions—Wheel base, driving, 7 ft.; wheel base, rigid, 16 ft. 6 ins.; wheel base, total, 27 ft. 3 ins.; wheel base, total, engine and tender, 52 ft. 10½ ins.

Valves—Greatest travel of valves, 6 ins.; outside lap of valve, 1 in.; inside clearance of valve, ½ in.

Wheels, etc.—Dia. and length of driving journals, 9¾ ins. dia. x 12 ins.; dia. and length of main crank pin journals (main side rod 6½x7 ins.) 7 ins. dia x 4¾ ins.; dia. and length of side rod crank pin journals, 5 ins. dia. x 3¾ ins.; engine truck, journals, 6 ins. dia. x 12 ins.; dia. of engine truck wheels, 36 ins.; brake.

Boiler—Thickness of plates in barrel and outside of fire box, ¾, ½, ⅝ in.; fire box, length, 96¾ ins.; fire box, width, 75¾ ins.; fire box, depth, front, 80¾ ins. back, B. 69 ins.; fire box plates, thickness, sides, ⅞ in.; back, ¾ in.; crown, ⅝ in.; tube sheet, ½ in.; fire box, water space, 4 and 5 ins., front; 3½ and 5½ ins., sides; 3½ and 4½ ins., back, tubes, number, 398; dia. 2 ins.; length over tube sheets, 16 ft. 0 in.; grate surface, 50.3 sq. ft.

Tender—Weight, empty, 46,000 lbs.; wheel base, 16 ft. 5½ ins.

can locomotives as furnishing a very small boiler, for in ordinary practice nowadays such a machine would have at least 1,800 sq. ft. total heating surface and probably 33 sq. ft. of grate area for soft coal. The fire box area would not greatly differ on account of the fire box probably being shallow and over the frames. The principal reasons for such a small boiler having being found sufficient are (1) the low pressure formerly used, (2) the good quality of soft coal, and (3) locomotives not being forced to develop their maximum power in continuous haulage. As the length of the flues sometimes depends upon the design of the locomotive, where the boiler has to be made unusually long on account of the wheel base, etc., it is common practice to give an excess of area in flue heating due to the fact that the front ends of the flues are not very efficient.

The arrangement of the flues determines the diameter of the boiler shell. The flues being in general practice arranged in vertical rows to facilitate the circulation of the water, and the distance between flues, called the bridges, depends upon the quality of the water supplied, ⅝ in. being about the minimum and 1⅜ in. the maximum, for water with a large amount of scale forming matter.

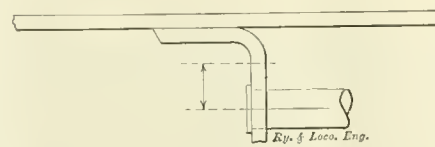

FIG. 1.

It may not be out of place here to make a few remarks on the question of steam space. Some years ago the locomotive department of one of the large railroads had considerable trouble with a class of consolidation engines which were continually giving out on account of burnt crown plates, and the engineers were generally blamed. In this case the boilers were of the level top type, and the distance between the fire box and the top of the shell was 16 ins., the normal water level being only 4 ins. above the crown. Thus the engineer was certain either to have a burnt crown sheet or to have the water priming and destroying the lubrication of valves and cylinders. It is not unusual to find boilers 60 ins. diameter which have not more than 45 cubic feet of steam space when the water is at the normal level 6 ins. above the crown. On the other hand there are boilers which have 100 cubic feet or more under the same conditions, which arrangement certainly prevents priming, especially for alkali water, and promotes economy. For the same reason it is desirable to get the throttle as high as practicable above the water level.

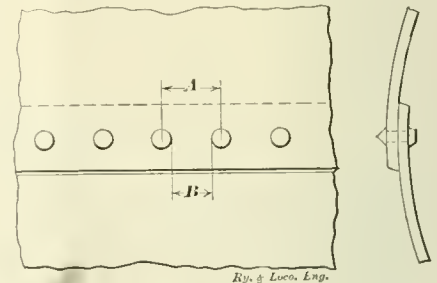

FIG. 2.

Then an allowance must be made for space between the flues and the boiler shell. This is generally about 2 to 3 ins., but is sometimes fixed by the center of the radius of front flue sheet corner being kept outside the widest flues, thus, Fig. 1. Over the top of the flues sufficient space must be allowed for the steam pipe and T-pipe flanges to clear the tubes and the top of the tube sheet. We have thus determined the smallest possible diameter of the front course of the barrel. At the back end of the flues the radius of the flue sheet corner must also be kept clear of the extreme flues both on the sides and top, which fixes the width of the inside fire box and the height of the crown. In narrow fire boxes to determine the width of the fire box shell we have to assign the length of the staybolts desired, which should be at least 6 to 7 ins. and on the top, we have to allow for water, say 6 ins., on the crown and steam space above. This should not be less than 18 ins. from crown to shell, in any design for a fairly large boiler, say 60 ins. diameter, and it is preferably 22 to 24 ins. if possible, especially for wagon top boilers. These dimensions determine the diameter of the back course of the barrel.

The quickest and most reliable method of measuring the steam space is to fill the boiler completely with water. Then set a barrel under the blow off cock and draw off the water, counting the number of barrels so filled, until the level comes down to the normal water line. Then weigh one barrel full and the total weight of water in pounds divided by 62.5 gives the cubic feet of steam space.

Having decided, from the general design of the engine, upon the steam pressure required we may now proceed to find thickness of plates, and design joints, etc. In all boilers it is usual to design them so as to have if possible a factor of safety of 5; that is, the calculated bursting strain should be five times the working pressure. This brings us to the calculations for strength of joints of different types, which we will put in the simplest possible form.

RIVETED JOINTS.

In all riveted joints there are two distinct types of failure to be provided against (1) tearing the plate along the row of rivet holes, and (2) shearing the rivets off. There is a third type of fail-

Designing of Locomotive Boilers.

BY ROGER ATKINSON.

(Continued from page 162.)

HEATING SURFACE AND GRATE AREA.

The size of a boiler is determined by the heating surface and grate area to be provided, these quantities depending principally upon the size of the cylinders. Probably the best known rule, which was followed for many years in British practice, was that originated by D. K. Clark. It was as follows:

Cylinder area (one cyl.) in sq. ins. $\times 5 =$ total heating surface in sq. ft.

Grate area $\times 70 =$ total heating surface in sq. ft.

Fire box area $\times 10 =$ total heating surface in sq. ft.

In other words, the area of one cylinder in square inches $\times 5$ gave the heating surface in square feet, which is divided into 90 per cent. tube surface and 10 per cent. fire box surface, and the grate area was ⅓ of the total heating surface.

If we were to apply the above rule to a locomotive with 20 in. cylinders we should get 1570.5 sq. ft. of total heating surface of which 157 sq. ft. would be fire box surface, and about 22½ sq. ft. of grate area. This would strike any one familiar with modern designs of Ameri-

ure where the edges of the sheet tear out at each rivet, but this is extremely rare, and easily provided against by sufficient lap as it never occurs with any but single rows of rivets.

Now to take the simplest form of joint, the single riveted lap joint, Fig. 2, and consider it under condition (1), failure of plate. Measure the minimum distance from center to center of rivets, A, or take the average of a number of such spaces. If we deduct from this the diameter of the rivet, after driving, or size of hole punched, we get the remnant of plate between the holes. B. Now a small proportion problem will be in order: take $A = 2\frac{1}{4}$ ins., the rivet hole $\frac{7}{8}$ ins., give $B = 1\frac{3}{8}$ ins., then $2\frac{1}{4} : 1\frac{3}{8} :: 100 :$ the percentage strength of joint; or in other words the original amount of plate between centers of rivets is to the remnant of plate left after punching, as 100, the original plate, is to the percentage of plate left; in this case = 61.1 per cent. Now suppose the plate to be $\frac{1}{2}$ in. thick, and the diameter of the boiler to be 50 ins. inside. The strength of the barrel is calculated for each inch of length, or in other words we take an imaginary slice across the boiler 1 in. thick, which gives a hoop of plate 1 in. wide

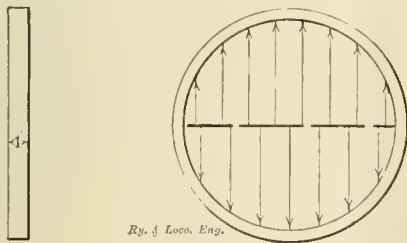

FIG. 3.

by $\frac{1}{2}$ in. thick at each side, thus, Fig. 3, which the steam pressure is tending to burst as shown by the arrows. The effective pressure of the steam acts on a line across the boiler equal to the diameter or 50 ins., and the width of this is 1 in., so that there is 50 sq. ins. of area at the boiler pressure, which in this case we may assume as 150 lbs. We have, therefore, 50 sq. ins. \times 150 = 7,500 lbs. tending to burst a hoop 1 in. wide of the boiler, which is resisted by the two strips of plate at the sides each 1 in. wide \times $\frac{1}{2}$ in. thick, or a total of 1 sq. in. Now the breaking strength of boiler steel is taken as 60,000 lbs. per sq. in., and we would have 60,000 lbs. to resist the 7,500 lbs. of bursting pressure, but as the joint in our example has only 61.1 per cent. of the plate remaining, we must reduce the plate strength of 60,000 lbs. to this proportion, thus: $\frac{60,000 \times 61.1}{100} = 36,660$ lbs.

plate strength. Then $\frac{36,660}{7,500} = 4.888$ as the factor of safety, or the number of times which the calculated bursting pressure is greater than the assumed working pressure. The foregoing example is

only for the plate strength and we have to calculate the rivet strength, or strength of the rivets to resist shearing.

In calculating for rivet strength we have to consider that each rivet in the example given has to carry the strain of one side of a section of the boiler $2\frac{1}{4}$ ins. wide, since the rivets are $2\frac{1}{4}$ in. pitch; that is,
 $50 \text{ ins.} \times 2\frac{1}{4} \text{ ins.} \times 150 \text{ lbs.}$

2

The area of a $\frac{7}{8}$ in. rivet is .6013 sq. ins., and if we assume the tensile

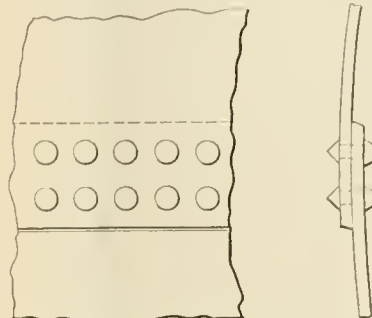

FIG. 4.

strength of the iron rivets to be 48,000 lbs. per square inch, then $.6013 \times 48,000 = 28,862$ lbs. for strength of rivet, and 28,862

$\frac{28,862}{8,437.5} = 3.42$ factor of safety through

the rivets. This shows that the assumed single riveted lap joint would be much too weak for safety, without making any allowance for making a tight joint. We should, therefore, be compelled to design a joint with more rivet strength. If this joint were double riveted on the chain system, thus, Fig. 4, we should get a factor of safety on rivets of 6.84. It is common practice by some authorities to

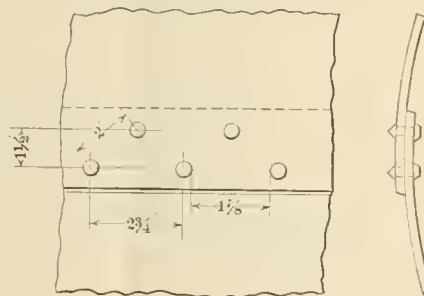

FIG. 5.

demand that the rivet strength for iron rivets shall be equal to $13/8$ of the plate strength for steel plate. This allows a margin of strength in the rivets to make a tight joint.

Now, suppose we take, for example, a double riveted joint with the rivets arranged zigzag, thus, Fig. 5, and apply it to the boiler in the former example. The distance apart of the rivets in the zigzag pitch should be $6/10$ of the straight pitch, $+4/10$ of the rivet diameter, and if we take $2\frac{1}{4}$ ins. as the

straight pitch we get about 2 ins. for the zigzag pitch and $1\frac{1}{2}$ ins. between rows of rivets. This makes the plate strength on the zigzag pitch equal to the plate strength on the straight pitch. The latter in per cent. of solid plate is then found thus:

$$2\frac{1}{4} : 1\frac{1}{2} :: 100 : \text{Ans. } \frac{1\frac{1}{2} \times 100}{2\frac{1}{4}} = 68.2$$

percentage of joint on plate, and the strength of plate for 1 in. of barrel is $\frac{40,920}{7,500}$

$68.2 \times 60,000 \text{ lbs.} = 40,920 \text{ lbs.}$ and $\frac{40,920}{7,500} = 5.46$ factor of safety on plate. For the rivets, we have for each pitch of $2\frac{1}{4}$ ins. one full rivet and two halves, or one rivet per $1\frac{3}{8}$ ins. of length of seam, then, as in former case,

$$\frac{50 \text{ ins.} \times 1\frac{3}{8} \times 150}{2} = 5,193.75 \text{ and } \frac{28,862}{5,193.75}$$

$= 5.55$ factor of safety on rivets. If this were still not high enough we should, therefore, continue to try different kinds of joints in the same way, for instance, we might extend the lap thus, Fig. 6, and make a triple riveted joint. This would have the same plate

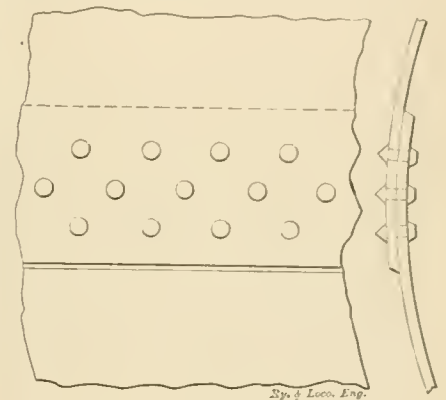

FIG. 6.

strength as in the last case, but the rivet strength would be increased to one full rivet and four half rivets, or equal to three rivets per pitch.

(To be Continued.)

There are about 600 miles of railway in Greater London, and some 600,000,000 train journeys are made in a year. The busiest hour is from 9 to 10 A. M., when 384 trains arrive at the London termini.

A Swansea collier who was knocked down between the rails by a Midland Railway train kept still until the whole train had passed over him, and when he was examined was found to have received only a slight scalp wound. He was just congratulating himself on having got off so easy when a constable seized him and dragged him before a magistrate, who fined him £1 and costs for trespassing on the railway line.

Growth of the Locomotive.

BY ANGUS SINCLAIR.

(Continued from page 177.)

MASON BEAUTIFIES THE LOCOMOTIVE.

Up to the time that William Mason began building locomotives in 1852, the ideas of art harmony as applied to locomotive designing appear to have had no place in the minds of men carrying on the

turesque scenes on headlights, cab panels and tenders.

Mason took the lead in making locomotives that were handsome without the aid of glittering brass and ostentatious painting. Mr. M. N. Forney, in the course of an obituary notice of William Mason, says: "He was a wonderfully ingenious man and combined with his ingenuity a high order of the artistic sense, so that his work was always

MASON'S WORK AS A LOCOMOTIVE BUILDER.

Mason began building locomotives at Taunton, Mass., in 1852, and his first engine is here illustrated by half tone engraving. The engine was built for the Jefferson Railroad in Indiana, and Reuben Wells, now general manager of the Rogers Locomotive Works, who was then master mechanic of the railroad named, received it. In a letter to *Locomotive Engineering*, published in 1898, Mr. Wells described the engine. He wrote: "It was called the 'James Guthrie' for one of the directors of the road and Secretary of the Treasury under President Pierce. The engine was of the eight-wheel American type, cylinders $13\frac{1}{2} \times 22$ inches, drivers 66 inches diameter, weight about 60,000 pounds."

"The cylinders were horizontal and were interchangeable, but bolted to a cast iron saddle, in whose upper face the smoke box rested and to which it was bolted. The cylinders were attached to this saddle at the frames, one bar of which passed under and the other over this saddle at the point where the cylinders were attached, and all were bolted together there. The inside face of the cylinder and the base of the saddle where they joined made the joint for the exhaust passage, the latter extending inward and upward to the base of the exhaust pipes, which were double with tips as high as the top row of tubes. The steam chests had

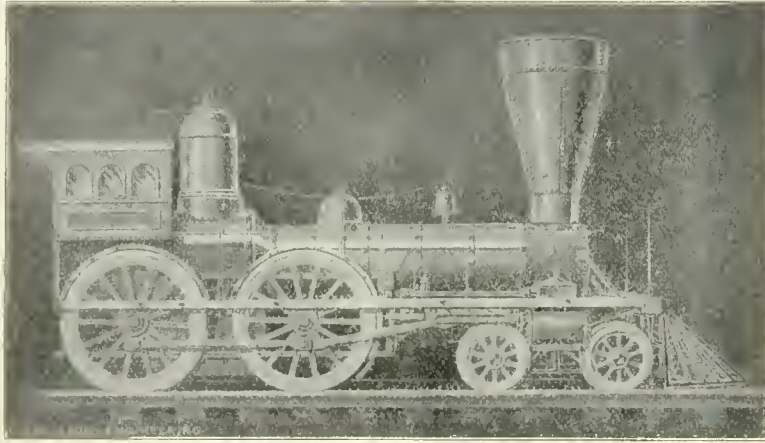

MASON'S FIRST ENGINE, 1852.

work. They labored with some success to produce locomotives that did the work of hauling trains with fair economy, and they worked out proportions that provided the required strength without carrying a burden of unnecessary material; but no attention appears to have been bestowed upon the outward appearance of locomotives so far as making the visible outlines harmonious was concerned. There was a great deal of ornamentation put upon some of the parts, but the effect on æsthetic taste was often grotesque where beauty was aimed at. Elaboration of brass in bands and coverings of domes, sand boxes, wheel covers, steam chests and cylinders with great vagaries of paint on other parts, conveyed the impression

most exquisitely designed. It might be said of his locomotives that they are "melodies cast and wrought in metal."

BUILDING LOCOMOTIVES FOR FUN.

In the course of an interview con-

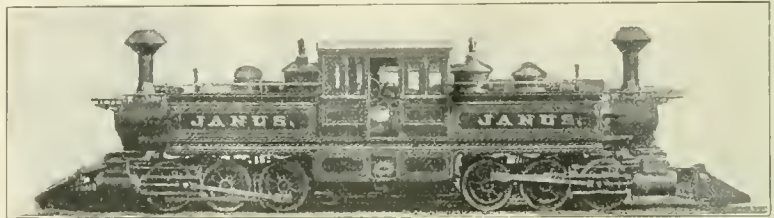

MASON'S DOUBLE END LOCOMOTIVE. FIG. 53.

cerning his business, Mr. Mason said: "My principal business has been making cotton machinery. At the time I commenced locomotive building, there was a little slackness in cotton machinery, and for that reason I took hold of locomotives. My locomotive business is now the meanest part of it and always was. I took an interest in it and tell my friends that I got up locomotives for fun, but that it was the most expensive fun I ever had. I make just enough money from my cotton machinery to make up the losses on locomotives." That may explain why so many concerns were overtaken by financial disaster building locomotives.

As Mason's work exerted great influence on locomotive construction in the United States, I shall give more particulars concerning his first engine than it is convenient to give to other celebrated locomotives.

a goose neck extension from their inner side into the smoke box to which the steam pipe was secured, as shown at B C, Fig. 52. The head and nut were 'balled' to make the joints and a cast iron ring bent on one face and balled on the other made the joint P.

"The steam ports were about 13 ins. long, tapered $1\frac{1}{4}$ ins. wide in the middle and 1 in. at the ends. The joints of steam chests and cylinder covers were flat and a gasket of sheet copper was used to make them steam tight. The cylinder heads were made hollow to provide an air space and they were polished for scientific reasons.

"The throttle was a slide valve located in the smoke box, operated by a rod inside the dry pipe, which ran from it to the usual style of lever on the boiler heads.

"The boiler was wagon top but without the usual taper connection, the bar-

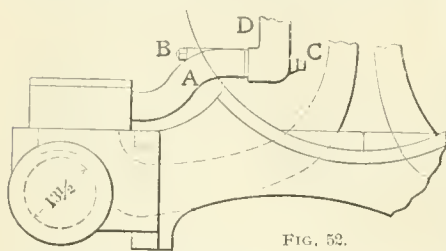

FIG. 52.

Locomotive Engineering

CYLINDER ARRANGEMENT OF MASON ENGINES.

one receives from looking at the garments of an overdressed woman. Those were the days when the red smoke stack and vermilion painted wheels were regarded as a mark of distinguishing beauty. It was then considered the correct thing to spend hundreds of dollars on the painting of portraits or pic-

rel of the boiler being flanged to the fire box sheet. The crown sheet was supported by bars, the tubes were of brass 2 ins. diameter and 11 ft. long. The iron fire box was about 33x48 ins. inside providing about 11 sq. ft. of grate area.

"The crossheads were of cast iron lined with babbit metal working in iron guides. The valves were worked by a shifting link motion of a pattern practically the same as that used to-day. The lifting shaft was located above the eccentric rods, the eccentric straps were of cast iron attached to flat ended eccentric rods by three bolts."

Special claims for advanced practice were made for the engine frames, but I shall use Mason's own description of his design. In the course of the interview already quoted from, Mason said:

MASON ON WHAT HE DID FOR THE LOCOMOTIVE.

"The most popular locomotives at that time were those built by Rogers. The first idea I had about improving the engine was to put the cylinders down level. As it was built at that time, the locomotive looked like a grasshopper. The old Baldwin engines were worse in this respect than the Rogers. The cylinders were all set up so as to be above the truck. Another thing on the old fashioned engines was, that if anything was the matter with the frame at either end, you had to take the whole engine down. I was the first to make the front end of the frame separate from the back end so that one part could be removed without removing the other

"Rogers used the link motion before I did; but he hung it from below. I hung the link above the center and had the suspension hanger the same length as the rocker arm so that the link block would not slip at all. At that time I was trying to prevent the slipping of the block, but I found afterwards that the slipping of the block was of little consequence, because if it slides at all, it is just as well to slide six inches as two inches, so far as the wear is con-

cerned. A little motion of that kind sometimes wears more than a long motion. I introduced the use of conical ended stay bolt for the crown sheet and everybody soon adopted that plan. I designed the arrangement of wedges in the jaws for locomotive driving wheel boxes. I put a shoe next to the box and a wedge behind the shoe and between it and the frame, so that the wedge was out of sight. Rogers

memory played him tricks that made him imagine that he originated improvements which other minds had devised. His work on improving the appearance of the engine was genuine and he took the lead in making the parts interchangeable. The locomotives designed and built by Mason indicate that he understood thoroughly the practical purpose they had to serve and the difficulties to be met and he provided for the requirements in a thoroughly skillful manner, natural to a man who was a first class mechanic. When he undertook, however, to build an unusually powerful locomotive to meet the demands of transportation interests that he perceived was bound to come, his work was not successful. He devoted immense labor and expended no end of energy and money in putting upon the market double ended locomotives, as shown in Fig. 53, and locomotives having the driving wheels arranged as a flexible truck. No particular advantage was found in the arrangement and Mason's "bogie" engines as they were called, attained no popularity.

Mason's eight wheel engine established the form of the so called American type of locomotive, and all that subsequent builders did for many years was to increase the proportions. A variety of odd forms were tried at various times but the engine with horizontal cylinders over a spread truck, well balanced driving wheels with cast iron centers divided frames and wagon top boiler held supreme favor, minor differences in details providing the excuse for designers and builders speaking of certain engines being their standard.



MASON'S SAXON, A FAMOUS ENGINE IN ITS DAY, ABOUT 1856.

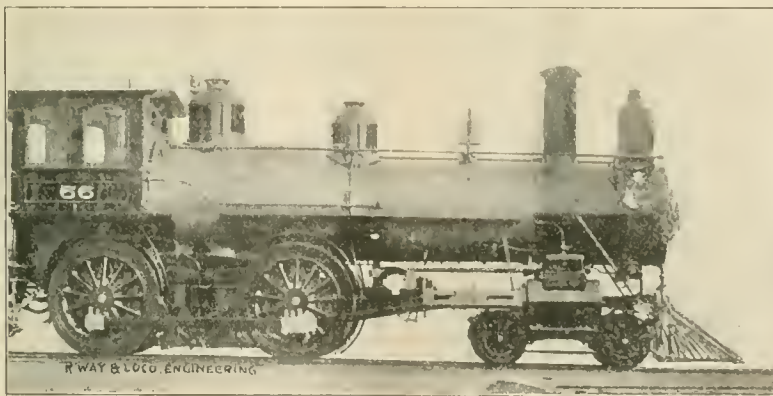

ONE OF THE LAST OF THE MASONS FOR OLD COLONY RAILROAD.

parts. I made the driving wheels with hollow spokes and hollow rim. I also got up a set of truck wheels. Before that the ordinary truck wheels looked like cheeses. I wanted my truck wheels to have some relation in appearance to the drivers; therefore, I never put a plate wheel under any truck that I built. I also put the corner balance into the rim of the driving wheels by pouring lead into it and now I have down to perfection.

adopted that plan. After a while I found that it was not a good way to have a wedge on both sides, because the men running the engines were sometimes careless and would shove up one side too much, so I made one side of the frame straight and put a wedge on one side only. I now make both jaws straight and put the wedge behind the shoe."

OPINION OF MASON'S WORK.

Mr. Mason went on at considerable

FORCES THAT DEVELOPED THE LOCOMOTIVE.

Scientific theories concerning steam and the steam engine provided very little help to early locomotive designers in proportioning the dimensions likely to produce the most satisfactory results. It was easy to calculate the strength of boilers and the thickness of plate necessary to withstand certain pressures, it was within the ability of most locomotive designers to figure out the power transmitted through the cylinders; but ascertaining the proportions of boilers to cylinders and the proportion of stroke of cylinder to the diameter were for a time unknown quantities, as was also the proper weight on driving wheels to provide necessary adhesion, all of which questions were settled principally by experience.

POPULAR LIKING FOR FAST LOCOMOTIVES.

As I have previously remarked, many of the early locomotive designers believed that the size of driving wheels measured the speed capacity of a locomotive. There seems to have been a curious propensity towards building locomotives capable of attaining a speed of not less than sixty miles an hour, even where the track was not safe to carry trains running at half that velocity. They built the high speed engines and learned, in a way not to be easily forgotten, that the boilers would not generate the steam necessary to keep the wheels turning. Associated with big driving wheels were cylinders so large that they used up the steam faster than the small boilers would generate it, which taught the men in charge that

ers favoring a stroke decidedly longer than what afterwards became nearly an established rule, while others favored making the length of stroke nearly that of the diameter.

When the Crampton engine "Stevens" was designed by Robert L. Stevens and Isaac Dripps, the cylinder proportions settled on were 13 ins. diameter and 34 ins. stroke. The first engine built of that type being found deficient in tractive power, a thing not to be wondered at with its driving wheels 8 ft. diameter, the designers determined to increase the piston stroke of succeeding Crampton's to 38 ins. The change did not prevent the locomotives from being failures, but that stroke was the longest ever tried for locomotives.

In two engines with a single pair of driving wheels 7 ft. diameter built by William Norris in 1850 for the Erie Railroad, the cylinders were 14x32 ins. The experience gained with these engines indicated to designers that a shorter stroke with larger bore of cylinder would produce better results.

SETH BOYDEN'S ENGINE.

A notable case of an abnormally long stroke engine was that of the "Orange" built by Seth Boyden in Newark, N. J., in 1837, for the Morris & Essex Railroad, now a part of the Lackawanna system. The cylinders were 8 $\frac{1}{4}$ x26 ins., making the stroke more than three times that of the diameter. That locomotive had no counterbalance weights in the driving wheels, and it may safely be assumed that the swing of the crank pin and its connections 13 ins.

the diameter and others had the same diameter and stroke dimensions. The arguments advanced in favor of the short stroke were that it produced a superior expansion of steam in the cylinders and that it made a free running engine with low piston speed. The arguments against the short stroke were that it transmitted excessive shocks to the bearings and that the least defect



SETH BOYDEN.

of the valve gear detracted from the power of the engine in slow pulling.

The early British locomotive builders seem to have found a good proportion of diameter to stroke of cylinders very early, for the Stephenson engines which the Locks & Canal Company used as patterns had diameter of cylinders about seven tenths of the stroke in inches. That proportion has been very little varied from up to the present time.

(To be Continued).

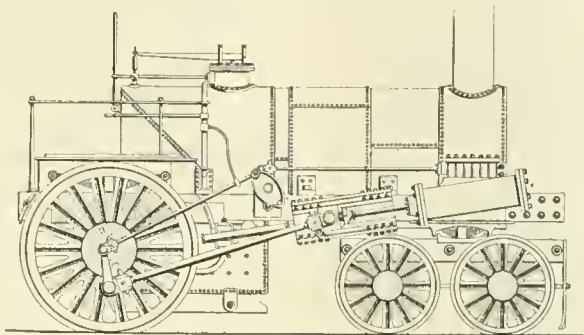

ORANGE, BUILT BY SETH BOYDEN AT NEWARK, 1837, FOR MORRIS & ESSEX RAILROAD.

there was an intimate relation between the heating surface of the boiler and the size of the cylinders. Large cylinders also produced excessive slipping of driving wheels, when the weight thereon was insufficient; so through expensive blunders the pioneer locomotive designers and master mechanics found out the proportions likely to produce a good working locomotive.

PROPORTIONS OF CYLINDERS LONG AND SHORT STROKE.

For years the length of stroke was a matter of controversy, some design-

ers from the center of the axle, would provide an eloquent object lesson as to length of stroke and want of counterbalance. This engine had a peculiar valve motion actuated by a single return crank, operating through an elliptical disk which effected reversing in the way the early Baldwin engines were reversed with a hook that engaged the upper or lower pin of a rocker arm, an arrangement devised and used by Carmichael, a Scots marine engine builder, many years before.

A few early locomotives were built with the stroke of cylinders less than

Locomotive Building at Milwaukee.

The Chicago, Milwaukee & St. Paul will built forty new locomotives in their shops at West Milwaukee during the coming summer. The first will be completed about May 1. Fifteen other freight engines of the 2-10-0 type will be built, and fifteen passenger engines, one of the Pacific type, and the rest the Atlantic and other types, will be built. The severe winter just passed demonstrated that the road needed more motive power.

Ever since the improvements were made at the West Milwaukee shops last year, engines have been turned out at the rate of two or three a month, until now there are about eighteen locomotives complete. In addition to this the regular number of cars are being gotten out.

Energy may be regarded as manifesting itself in two forms. One may be called the army form, where it is held under control, the other is the mob form where it runs wild and is directed into no useful channels.

General Correspondence.

Brotherhood Convention Notes.

WHAT MAY BE SEEN DURING THE VISIT TO CALIFORNIA.

In order to see all the beauty of the region west of the Rocky Mountains one would need to make the trip several times, going and coming each time by a different route. Every far western railroad touches points of wonderful interest. Those of our readers who may have the good fortune of a trip to the western edge of the continent, particularly those who will attend the biennial convention of the B. of L. E., at Los Angeles, on the 12th of May, there will be many opportunities for seeing the marvelous sights of California and the Pacific Coast whatever route they may take. The northern routes give the traveler a chance to see the typical western city of Denver, the interesting city of the Mormons at Salt Lake, the lake itself, the grand old Rockies, Ogden and the Lucin cut-off, or Colorado Springs and Manitou. There are deserts brown and gray or white with alkali, and deserts reclaimed to verdant green by irrigation. On the Central Pacific one passes in a few hours over the summit of the Sierras from desert to the garden of the world.

The more southern routes offer opportunity to visit the Grande Canyon of the Colorado, if one can spare a few days. Still another southern route goes through the cotton belt. However, even without side trips, the uninterrupted journey across mountain and valley and desert will be full of interest—the very strangeness of the scenery will be fascinating. The season is too early for intense heat or dust.

In Los Angeles there is an abundance of sights to amaze eastern eyes. Probably all convention visitors will go up the incline to Mt. Lowe, besides visiting the old missions of Los Angeles and San Gabriel. Of course, everybody goes to Santa Catalina Island.

People from the inland States will especially enjoy the numerous seaside resorts. Santa Monica is the nearest and most convenient. Redondo Beach and Terminal Island, where surf bathing can be indulged in, are also easily reached.

The engineers will all want to see the Southern Pacific shops at Los Angeles and those of the Santa Fe at San Bernardino. The great breakwater at San Pedro, a huge undertaking by our government, will also interest them.

If time permits, every visitor to the coast ought to see something of California north of the Tehachapi Pass. A short trip to the beautiful Yosemite Val-

ley will be a pleasant memory for after years. Then there are famous Calaveras Big Trees. Even if one takes the direct trip to San Francisco, a few hours will be sufficient for a side trip to the big trees of Santa Cruz county or those

the Seal Rocks and the seals themselves. All these can be seen in one afternoon. Many different lines run out there, but the one on the north side of Golden Gate Park affords the finest imaginable view of the Golden Gate. Across the bay to

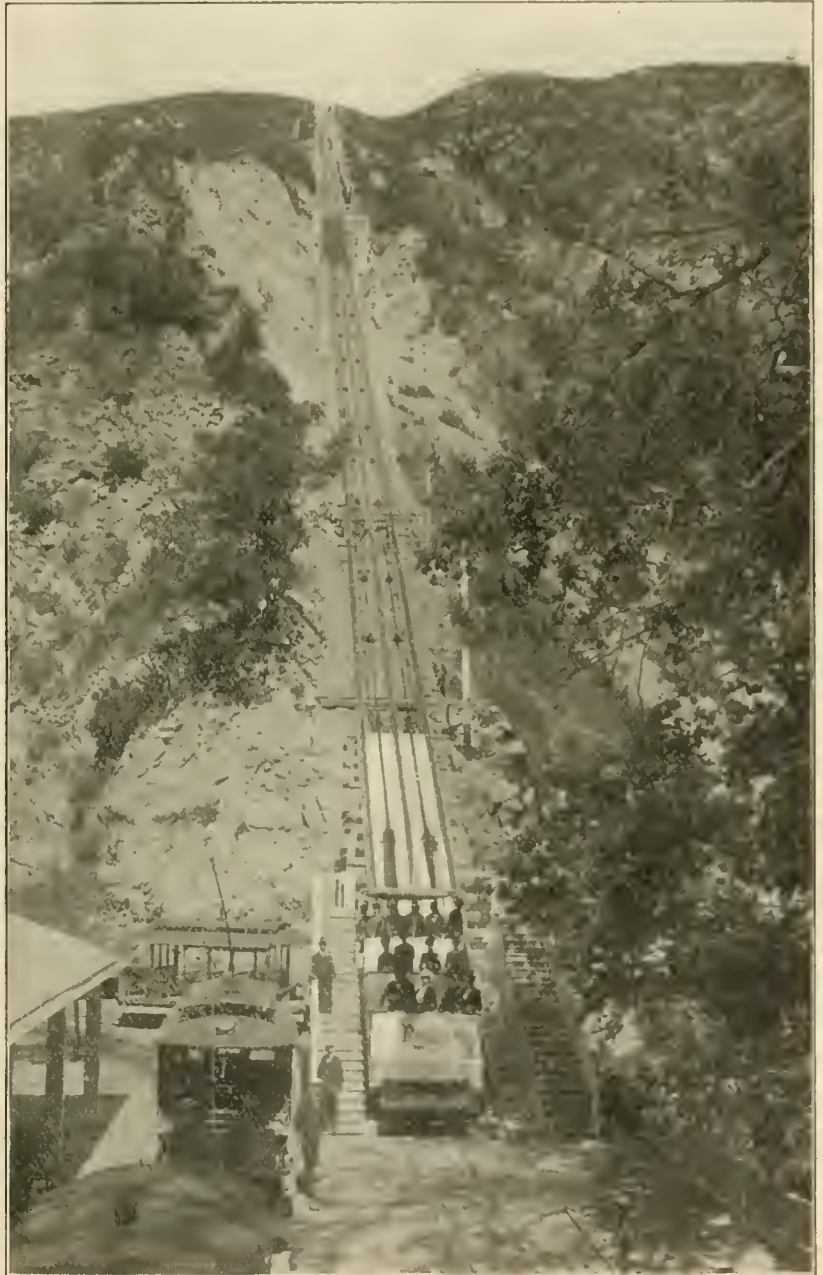

MOUNT LOWE, NEAR LOS ANGELES.

Ought to be Visited by People Attending Locomotive Engineers' Convention.

of the Russian River—none of which compare with the renowned giants, but still many times larger than any trees that grow elsewhere in the world.

All the world has heard of the San Francisco Cliff House, Sutro Heights,

the east is the State University and south, in Santa Clara county, is Stanford University, both well worth seeing.

Crossing the bay toward the north there is a delightful ride up Mt. Tamalpais. To the west from the summit

the eyes gaze on the Pacific Ocean, whose waves lap the foot of the mountain. On the left is the Golden Gate and behind is the bay. In the eastern distance on a clear day it is possible to see across the State to the snow-clad Sierras.

Scott's Union Iron Works are on the extreme south side of San Francisco. There some of our famous battleships

The Shasta route, between Sacramento and Portland, Ore., enables one to see Mt. Shasta, Mossbrae Falls, the Upper Sacramento Valley, and the Siskiyou Mountains. The sluggish river of the lower valley is here a brawling mountain stream. The mountains are covered with evergreen trees and differ entirely from the grander Rockies, but the scenery is picturesque and beautiful

fruits. It is safe to say that the eastern visitor on his first trip to the Pacific Coast will see more flowers in one day than in a whole season at home.

The reputation of the Brotherhood as the most conservative labor organization is well known in California, and every visitor to the Convention will meet a hearty welcome. The California members of the order, as well as the citizens of the State, will use every effort to make the Los Angeles Convention a memorable event in the lives of those who attend.

J. A. BAKER.

Slipping Shut Off.

Noticing an article in your December number about engines slipping when shut off; I can say that I had that experience about four years ago. I was running a Schenectady eight wheeler eighteen by twenty-four cylinders. She was just out of the shop and the man making the trip before me had sprung the right main pin. The trip I had her, a few miles out, at high speed, she commenced slipping, and when shut off slipped for a long way. When examined, both driving journals on right side were badly sprung. Her side rods were strap bolted, so I took out the forward key and went on; if they had been solid end side rods I would have had to take them down. The rail was bad owing to a light rain. The engine repeated this slipping three times on this trip, the train being a fast passenger.

C. B.

I see in RAILWAY AND LOCOMOTIVE ENGINEERING, page 112, March number, that a master mechanic claims an engine cannot slip when running shut off; that the peculiar sensation experienced, sounded very much like engine was slipping when brought to a certain speed, and also your comment that slipping when shut off is misleading.

I would like to ask why an engine that has the peculiar sensation does not have the same sensation on sand or a dry rail at the same rate of speed. I remember the first time I was on an engine that slipped shut off going down a hill. I told the roundhouse foreman and the master mechanic about the way the engine acted; they told me I was "nutty" and had wheels in my head. At another time an engineer got ten days' layoff for making out the report that engine slipped while shut off, and sprung two new journals and side rods. The engine came out with two more new journals and sprung them while slipping shut off. The traveling engineer and another engineer were on the engine. This is the case I referred to in the February issue. The M.M. took the traveling engineer's word that engines did slip while shut off, and the consequence was reconsideration of the ten days' layoff for engineer, and they quartered the engine again. There was



MOUNT LOWE RAILROAD.

like the Oregon and Monterey, were built. The place is a mine of interest to every man interested in machinery.

On the way from San Francisco to Sacramento, the road runs through miles of orchards, all full of fruit at this season. At Sacramento the two main points of interest are the State capitol and the railroad shops.

Travelers to California may leave their revolvers at home, but not their overcoats. No matter how warm the day, the night is sure to be chilly.

Oranges will not be quite out of season, and as fine ones will be found growing in the valleys of northern California as in the South. Strawberries will be abundant and cheap, likewise other small

no more trouble about slipping when shut off on any kind of a rail.

I will admit it is as hard to get any one to believe that an engine will slip when shut off as it was for Columbus to make people believe that there was a new world over here. Yet it is a fact, just the same.

C. J. VEIG.

Osawatomic, Kans.

[The so called slipping shut off, due to a twisted axle, etc., is a retardation of the motion of the driving wheels of a locomotive, so that they revolve more slowly than the speed of the engine would otherwise produce, and the wheel drags. To put it another way, instead of one foot of tire measuring off one foot of rail all round, perhaps 8 ins. of tire runs or drags over one foot of rail. When engine slips under steam pressure perhaps 15 or 20 ins. slide over one foot of rail, but in either case there is a want of adjustment between the distance measured off by the tire and the length of rail gone over. If it does not seem wonderful that a slip under steam pressure should be checked by sand, why should not the drag of the wheel be checked in the same way. Sand on the rail increases the adhesion between rail and wheel and in a sense is like adding weight. The tendency to either kind of slip, ahead or retarded, is reduced by sand on the rail. If this is not the case, what is the force, and where is it applied which makes a wheel spin round ahead of the speed when steam has been shut off?—Ed.]

Good and Bad Firing.

The few lines by Twig, in your March paper struck me so hard I had to read it over again.

Hiring a fireman and letting him go it, as is done, is a good way to have a good man only once in a while and a poor one three or four times in a while. When you get to the engine house your regular man is off and an extra man is going out. Then on goes the blower; he rakes over the fire and gets the engine blowing off, then bales in coal, keeps blower on, and in the 30 or 40 minutes before leaving time, a couple of hundred pounds of coal is wasted. There are no pains taken to keep fire level before starting; they must wait until you start for that.

After you open throttle then open comes the door, and the fire is given a good raking. After you get out a few miles he happens to think that perhaps the fire is dirty, so he shakes the grates, but don't you say anything to him for he has fired three or four years, and knows his business, and so it goes the whole length of the road, raking and shaking and baling.

Now, Fireman, let me say, when you get to your engine to go out, if engine

is full of water and fire is bright, just keep adding a little coal on the bright places, and by the time you are ready to leave you will have a better fire and more of it. Don't burn it all with the blower, and a few minutes before you start loosen fire with bar and level it in good shape; scatter in a little coal to make fire solid, so when engine is

more fire out than you can help, for all the live coal takes so much heat from fire box.
L. W. T.

Cause of Wheel Distortion in Photograph.

In your March number you have an illustration of an automobile on a Florida beach, and a note beneath states that



ANOTHER VIEW OF MOUNT LOWE RAILROAD.

working hard starting train, fire will not be torn. Now that you are started, your aim should be to keep the fire level. If the run is long enough so fire will want ashes shaken out, do it when engine is not working steam, and before shaking grates get fire even and scatter in a little coal to get a good fire above the ashes that are to be shaken out, and just shake ashes: don't let any

the apparent bulging of the forward wheels is an unexplained phenomenon.

There is a cause for this as well as many other unexplainable things in mechanics and it is as follows: Remarkably short exposures, which are made even up to 1-2500 of a second, are made by what is termed a focal plane shutter. It is nothing more or less than a roller blind each end of which is fas-

tened to a roller, one above and the other below the plate. This blind has a very narrow slit in it which flies across the plate and exposes each part for an extremely short duration of time.

Now for the explanation of the phenomenon, so called. The car is running at a high rate of speed. The narrow slit starts at the bottom of the plate, and the top of the wheel moves ahead for just the period of time it takes for the slit in the blind to travel from the bottom to the top of said wheel, hence the elliptical image.

Hoping I have made this explanation clear to your readers, I am,

FRED JUKE.

Rawlins, Wyo.

Correction on "The Work of Ross Winans."

I have read with interest Mr. C. H. Caruthers' article on "The Work of Ross Winans," in your March issue, and find in it only a single lapse from the painstaking accuracy which always characterizes the work of Mr. Caruthers. This consists in the statement that the "Carroll of Carrollton" was one of the two engines built by Winans which "had the engineman's position at the extreme front—on the bumper."

I saw this engine several times in Winans' shop—the last time while she was being scrapped, and am, therefore, able to state, from personal knowledge, that the cab was located on top of the boiler, as in the camel engines. The error has arisen from confounding this engine with the "Centipede," in which the engineman's position was "at the extreme front—on the bumper." The figures given for the stroke of the "Carroll of Carrollton" (48 inches) are doubtless a mistake of the printer, and I have never heard of any locomotive having so long a stroke. I can find no record of the stroke of this engine, but my recollection is that the cylinders were 16 in. bore and 22 in. stroke. As I remember them, they appeared to be of about those dimensions, and the stroke of all the larger engines of Winans, was, I think, 22 ins.

Referring to the "Centipede," Mr. Caruthers says:

"The cab is stated to have been at the front end, but positive data seems wanting as to whether this means on the front bumper or merely in same position as on the camels."

I am glad to be able to furnish positive data as to this, the fact being, from my personal knowledge of the engine, that the cab was located in front of the smoke box and on a deck above the front end of the frame and the bumper beam. I remember very well that the throttle rod ran through the stack. After the "Centipede" was bought by the Baltimore & Ohio Railroad in 1863, the cab

was placed on top of the boiler. This engine had independent cut-off valves, worked, as I recall, from "sword" arms, and a peculiar design or truck, the details of which I do not remember.

It is much to be regretted that drawings of the two engines referred to have not been preserved, in view of their interest as examples of original designs in early practice. J. SNOWDEN BELL.

Pittsburgh, Pa.

Piston Valves.

The Master Mechanics, at their convention last July, had a lengthy discussion on the troubles of the piston valve and a great many roads gave their experience. The trouble seemed to be the loss due to shrinkage caused by broken packing rings, some roads gave no report, while others did, and I did not see that they found out whether the trouble was in the steam ring of the exhaust ring, as the trouble all seemed to be with the piston valve.

One road in particular has two engines in service changed from piston valves, but they had not taken any cards from them, while at the same time they



PROPOSED MODIFICATION IN VALVE STEM CONNECTION.

state that they are giving the very best service, and were going to meet requirements and come up to what was expected when the engines were designed.

If there are any merits in the piston valve and you can show me that that type of valve is more economical and more efficient than the slide valve, show me. Now, the piston valve is no new thing, as anybody knows, but it seemed all of a sudden to fall into style, as it were, and the fellow says might look the best, but has not proved the best after long, hard trials.

The piston valve has its merits and the valve might be improved, as I think it can be, and so overcome some of the defects. While this might not make it perfect, it might eliminate a whole lot of the trouble, which may make it more efficient, if they intend to use it, but it has its faults, non-shrinkage, caused by broken rings. The trouble or most of the trouble is caused by the valve wearing within the valve chamber and in one direction parallel with the valve stem. Now this stands to reason that the rings will wear O. K., possibly up to 15,000 miles if put up properly, and there may not be any shrinkage, but after that the rings wear more in one place and the consequence is that they have not the strength to stand the strain expected of them and they break, and then you have

shrinkage. Some say they don't know whether it is the steam ring or the exhaust ring, but it's both. What is the difference whether it's the internal admission or external admission, the trouble would happen just the same and you'd have leaks. I think the trouble can be greatly reduced. I enclose two sketches: one of a cross head, to show how a large piston rod got working in a cross head and I oiled it and let it work or turn, and it gave no trouble. One might suppose that a piston rod loose in the cross head would whirl around like a windmill, but it won't.

An engine, with a 21 in. cylinder, which I ran, had the piston rod loose in the cross head, the piston rod would turn a little when shut off or it would turn a little when the throttle was open. I cannot say that I saw or heard any pound in the cross head either. This loose piston rod was on the right side of the engine, and I watched it and the piston head never groaned, or gave any trouble, and in four months the left cylinder head had had the packing renewed four times, as it was in a bad water country. When the right cylinder head was at last taken off to see the condition of the rings, they were found to be in fairly good condition, and were worn equally all around. I am not saying I am the inventor of this. I can explain about it, as it really invented itself. If this large piston stood the racket why would not a piston valve do the same thing? Why does not the block in a scotch yoke pound or the block in a link? That's the trouble. Try this and put the piston valve up properly, and I am sure it will add materially to its success. The Burlington have about as much success with the piston type valve as any other road I know of, or any that was reported in the convention. They use the Clark packing ring and with that ring and the valve put up properly they do not notice any very great loss until after between 85 and 100,000 miles are made, which shows the efficiency of Clark's ring, which is an L-shaped ring.

It would not be expensive to make the change, and it might lead to the success of the valve. There is no patent on this device, as I said it invented itself, thank God.

I. COLLIER DOWN.

Slipping With Steam Shut Off.

In your January issue, there was inquiry as to the cause of an engine slipping after being shut off.

I have read all the reasons given by subscribers and they all seem to agree that the engine was not properly quartered. If this were so, all the roads in the country would have this trouble and it would not be so rare.

I have run engines out of quarter and

they all had a pound at one end of the stroke, and the fact that engines have been in service a good while before this slipping begins is evidence to me that it is not in the quartering. "Master Mechanic" is of the opinion that it is an optical delusion that the rattle of the rods was in the engineer's head and that the wheels slowed up instead of gained in velocity. If this were a fact, they would have revolved as quiet as if the rails were oiled.

I had two cases of engines slipping after being shut off and I cured them both in the same way. I had ample opportunity to watch the first case, as it was on a daylight run. I did not report it for several trips and when I did, the remarks made by the general foreman and others were anything but complimentary. I had been running the engine (an eight wheeler, 18x26, 68 in. wheel) about six months, when she began this slipping. About this time I noticed she

on the cars at different camps and sidetracks, making up trains of logs, drawing them to stations to be picked up by the regular trains, to take to the big mill at Samoa. This engine is used for hauling material and hauling and handling the heavy timbers for bridges, can be used in place of a derrick, is one of the most useful locomotives that I ever saw, as it is used for so many purposes. I told the superintendent and M.M. that it was the first locomotive I ever rode on that the engines run backward for the locomotive to go ahead.

I also send the photograph of the small bull donkey, with the M.M. in front. The company has three sizes of donkeys: Logging donkey, small bull donkey and the large bull donkey. The logging donkey is used in the woods and is on runners (page 84, of the February issue) by taking a hitch around a tree with wire rope and then around

managements were indifferent to the safety of railway operation in the United States. The Interstate Commerce Commission has been at special pains to impress the American public with the notion that American railways were not as safely managed as British railways, and that only the adoption of patent devices in signaling, braking and coupling would render them so. In order to cram this one-quarter truth down the gullet of the American people the Commission has continually instituted comparisons between the exceptional report of not-a-single-passenger-fatality-in-train-accidents on British roads in one year with the totals of all kinds of accidents on American roads. Where this comparison has not been made brazenly it has been made by implication so that whenever the Commission issued its bulletins of railway casualties the popular comparison has been with a phenomenal but restricted English record.

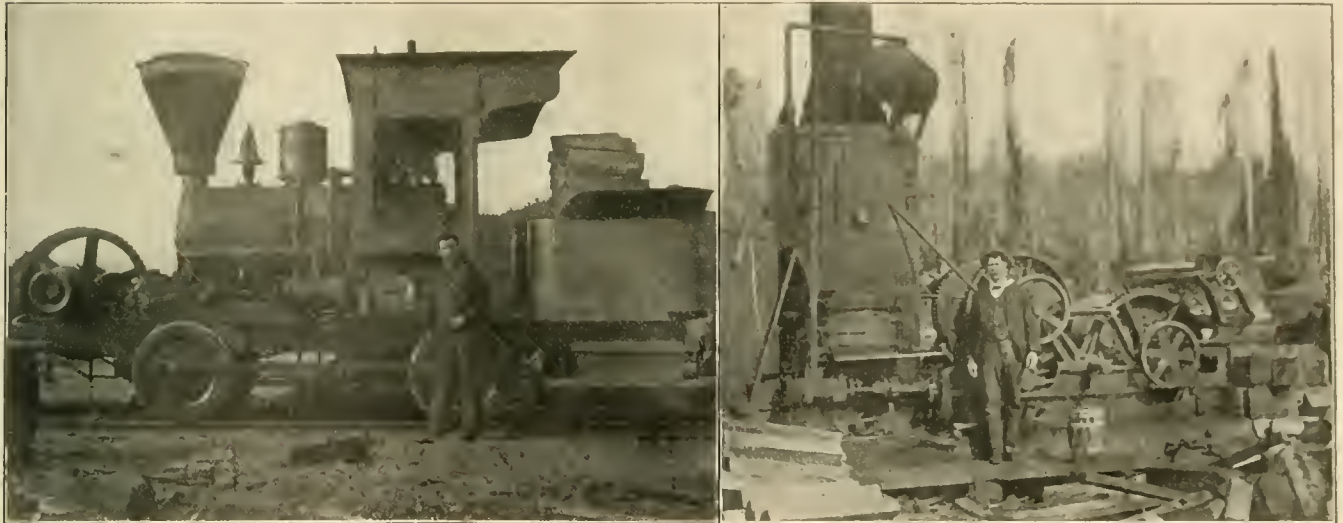

LUMBER WORKING IN CALIFORNIA FORESTS.

was getting twisted on her springs, i. e., low at one point and high at another. I had her lowered in front and blocks put in main driving spring hangers and leveled on the equalizers. I ran this engine for ten months after this and she never slipped after being shut off.

The conclusion I came to was that there was not weight enough on the main drivers and the train shoving her gave the counterbalance in the wheel a free action that started the slip.

W. J. STUART.

Traveling Engineer, Union Pacific.

Pictures of Engines on Lumber Railroad.

I send you a photograph that I received lately from my son, Mr. C. J. Chapman, M.M., of the Eureka & Klamath River Railway. The first is of the engine "Gypsy." This locomotive is used for several purposes: Loading logs

the spool and the shaft of the engine, the engine started. You can see the machine can be placed where needed. The small bull donkey is used at the smaller camps. The large bull donkey at the largest camps and the longest haul and the largest logs.

W. C. CHAPMAN.

Fremont, Neb.

The Mileage Basis for Comparing Railway Accidents.

While I entirely agree with the poet Cowper and your editorial in the April issue, that all are slaves who are in the chains of error, it seems to me that you do injustice to the great emancipator Truth when you decriy mileage as the basis for comparison of accident statistics on British and American railways.

For years the immunity from accidents of travel on British railways has been tacitly accepted as proof that American

Another favorite basis and one which you are apparently inclined to favor has been the passenger basis—ignoring the character of the traffic and the distance of the passenger haul; ignoring the enormous disparity in the freight tonnage and mileage; ignoring the fact that there are three American trainmen to one British trainman, and ignoring the adverse conditions of distance, climate and topography that render railway operation vastly more hazardous in America than in England.

In the pamphlet which called forth your comments I adopted the "mileage basis for comparison because it is the only one that affords any invariable common standard." It was not adopted because it was a scientifically true basis, but because it could be understood by the average reader, because it provided a single standard and because none other, at once so simple, single and common

the world over, contained as large a measure of Truth.

That this basis did no injustice to the comparative safety of English roads let me demonstrate by the following railway statistics taken from official sources:

	British 1902	American 1902
Length (miles)....	22,152	202,471
Capital per mile...	\$275,000	\$62,301
Passenger traffic		
No. carried....	1,320,000,000	711,000,000
No. carried one mile.....	9,140,000,000	21,543,000,000
Average passenger journey (miles),	7	30.30
Freight traffic		
Tons carried....	437,000,000	1,363,000,000
" " mile.....	17,494,000,000	178,650,000,000
Average haul per ton miles.....	40	131
Trainmen.....	72,634	225,422

I do not think that RAILWAY AND LOCOMOTIVE ENGINEERING will attempt to meet the significance of these compara-

freight service are ten times greater than confronts British railway operation.

Putting these two factors as represented in passenger mileage and ton mileage together and the chances for casualties are all the way from ten to twenty times greater on American railways than on British. This of itself more than justifies my using mileage as the basis of comparison and shows how moderate is the ratio of nine to one, which it yields.

The part freight traffic plays in the risk of travel on American railways has never been properly taken into account in discussions of this subject. The freight train mileage of the United States is nearly three times greater than that of the United Kingdom, and the weight per train four times greater.

railway employees outnumber the British trainmen three to one, and it is safe to say that they travel on an average three times as far, since the passenger train mileage here is twice and the freight train mileage three times as great.

I need not say anything of the dangers which winter blizzards and summer floods and tornadoes add to railway operation in America, but they have to be taken into consideration by every railway manager entrusted with the task of providing fast, cheap and safe transportation to a feverish public.

I acknowledge that this is a special plea, but it is a special plea for justice in comparing what American railways are doing in response to the American demand for rapid, cheap and safe transportation. Mr. Tunell has established the superiority of American railways in speed; the rates speak for themselves; and, if the mileage basis be accepted as just, their safety in proportion to the service they perform is unsurpassed.

All things considered I submit that the mileage basis affords a rational and not too favorable basis for the comparisons I have made.

I agree with you that "a strong impartial government commission, capable of inquiring into, not only the immediate, but the proximate cause of all railroad accidents" would be productive of good results. The inspecting officers of the Railway Department to the Board of Trade of the United Kingdom, of whom the well known Lt. Col. Yorke is chief, perform that office for the British railways. But with almost daily proof of the failure of the Interstate Commerce Commission to fulfill the plainest duties of its creation either with strength or impartiality, what prospect is there of securing such a commission as you suggest? The possibilities and opportunities of evil in a weak, prejudicial and incapable commission are too serious to justify its creation.

Chicago, Ill. SLASON THOMPSON.

Ancient Steam Heaters.

In the Dedham (Mass.) *Transcript* there are being published a series of reminiscences by an old and former resident of this old town. In these papers is mentioned, a quaint citizen long ago deceased, who had a shop where iron and wood working enterprises were carried on. It was this building the owner heated by exhaust steam, from his engine, prior to 1840, as he died in 1847 well advanced in years.

The pipes were cast iron, eight or ten feet long, six inches diameter and were flanged. The boiler was horizontal and had two flues. We glean from this fact that economy was practiced as early as 1840. There must have been others equally as enterprising and economical as the above.

HERBERT FISHER.

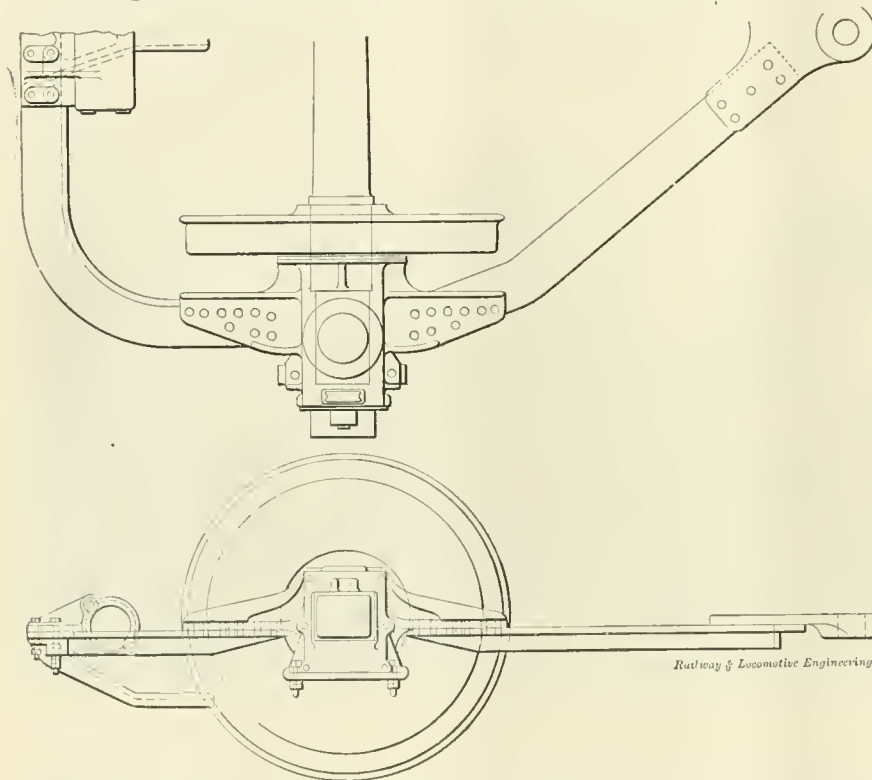

REAR OR CARRYING WHEEL TRUCK OF 4-6-2 ENGINE, N. Y. C. & H. R. R. R.

tive figures by questioning the fact, vouched for by *Engineering* (London), that the average passenger haul in Great Britain is only seven miles or exactly the average haul on our Illinois Central suburban service, which has carried over 100,000,000 passengers in nine years without a single passenger fatality in train accident.

You will hardly question that the chances of accident to a single passenger increase in proportion to the distance he travels and that therefore the mere physical chances of accident under precisely the same safety provisions are as 30.30 to seven against the American passenger, simply by reason of the greater length of his journey.

But passenger trains do not have a monopoly of the railway tracks in England or America, and the bare numerical chances of casualties from our great

Of 226 trains in the 134 most serious accidents reported for the year, to June 30, 1902, to the Interstate Commerce Commission 134 were freight and 92 passenger trains; and of the 92 collisions in these accidents 44 were between freight trains, 30 between freight and passenger trains, and only 18 between passenger trains. The smallness of the passenger traffic compared with the vast volume of freight on American roads accounts for the fact that the fatalities to passengers constitute only 4 per cent. of the total railway fatalities here, while they are nearly 12 per cent. of the fatalities on British roads.

But the freight traffic factor by no means exhausts the justification for the mileage basis as far within the bounds of fairness to British accident statistics. The trainmen who furnish more than 50 per cent. of the casualties to American

New York Central 4-6-2 Engine.

The engine here illustrated belonging to the New York Central & Hudson River Railroad was recently turned out of the Schenectady shops of the American Locomotive Company, and was received by Mr. J. F. Deems, general superintendent of motive power of the New York Central's lines. This 4-6-2 type represents the heaviest passenger power on that road.

The engines are simple, with cylinders 22x26 ins. The six driving wheels measure 75 ins. in diameter outside of tires, and the driving wheel base is 13 ft. The tractive effort as calculated according to the M. M. formula is about 25,800 lbs. The weight carried on the drivers is 140,500 lbs., and the ratio of tractive effort to adhesive weight is as 1 is to 4.92. The engine has, therefore, on her drivers nearly 5 lbs. weight for every pound of drawbar pull she can exert.

carrying wheels at the rear are equalized together. There is no traction increaser used, but three pivot holes in the equalizer between carrying wheels and rear drivers permit of some readjustment of weight in the shop. The trailing truck frame is, roughly speaking, triangular in shape, and is of the radial type. The pivot point being between the frames and almost opposite the brake shoe on the rear driver. The axle boxes of the carrying wheels are water cooled and the axles have outside journals. This arrangement leaves room for an ash pan the full size of the grate area. The size of the journals are 8 ins. diameter by 14 ins. long.

The boiler is 70 $\frac{3}{8}$ ins. inside diameter at first course and is of the straight top variety with crown sheet radially stayed. The roof sheet slopes slightly to the rear and the crown sheet has the same slope, keeping a steam and water

to the lagging, as shown in the illustration. The total depth of the smoke box is 75 $\frac{1}{16}$ ins., and the center of the smoke stack is 32 $\frac{1}{16}$ ins. back of the smoke box ring. The front flue sheet is just about on a line with the center line of the valve stem rocker. The arrangement gives a neat appearance to the front end and adds to the generally good effect produced by this excellent example of modern heavy passenger power. A few of the principal dimensions are given below:

General Dimensions—Weight in working order, 218,000 lbs.; weight on drivers, 140,500 lbs.; weight engine and tender in working order, 340,400 lbs.; wheel base, driving, 13 ft. 0 in.; wheel base, total, 33 ft. 7 $\frac{1}{2}$ ins.; wheel base, total engine and tender, 67 ft. 6 $\frac{1}{4}$ ins.

Valves—Greatest travel of slide valves, 6 ins.; outside lap of slide valves, 1 in.; inside clearance of slide valves, $\frac{1}{8}$ in.; lead of valves in full gear line and line, full forward motion, $\frac{1}{4}$ in. lead at $\frac{1}{4}$ stroke cut off.

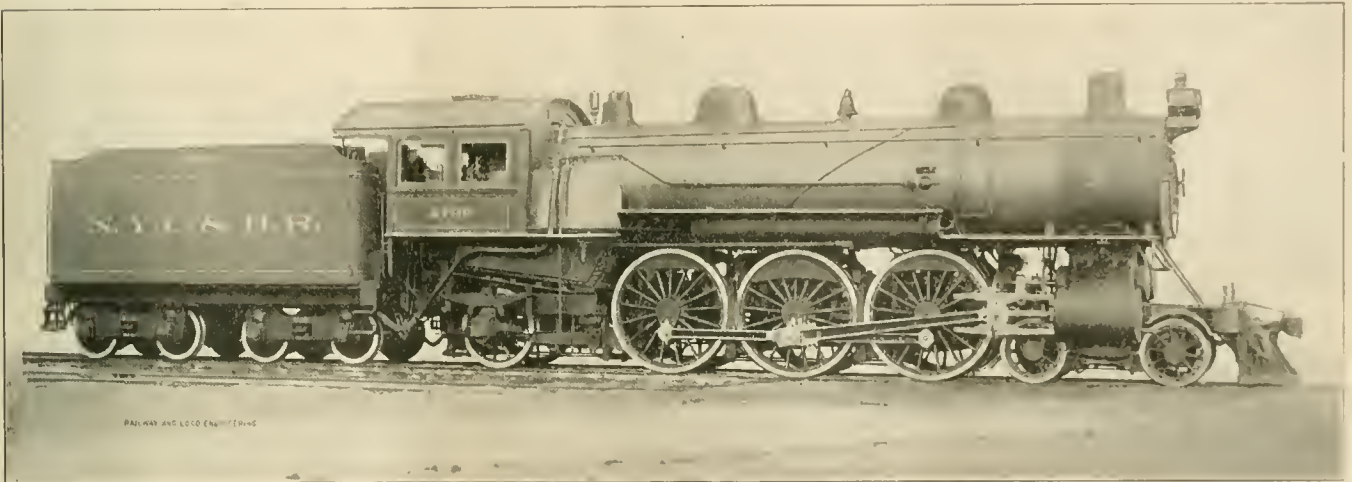

HEAVIEST PASSENGER ENGINE ON THE NEW YORK CENTRAL. 4-6-2 TYPE.

This proportion gives an engine which is not liable to slip on a clean rail at starting.

The frames of this engine are cast steel and the main frame and the frame front are all one, with strong lateral bracing. Each pedestal binder has a lug cast on the underside for convenient jamb nuts to hold the wedge bolt in place. The valves are of the piston type inside admission with indirect motion. The rocker on this engine has its center below the valve stem just as is usual with the majority of indirect valve motion engines, but the transmission rod passes up from the link block over the axle of the forward driver and is connected with the rocker on the level of the valve stem, thus producing what is called direct motion. As the valve gives inside admission and the motion is direct it follows that the centers of the eccentric will be on the same side of the center line of the axle as the crank pin is.

All the wheels are flanged, the springs are all overhung and the drivers and the

space between them about 20 ins. The tubes of which there are 303, are 20 ft. long, 2 $\frac{1}{4}$ ins. diameter. Their combined heating surface amounts to 3,553.8 sq. ft. The brick arch used in the fire box is supported on water tubes, which latter give 23.6 sq. ft. of heating surface. The fire box adds 180.3 sq. ft., making a total of 3,757.7 sq. ft. This heating surface is equal in area to a square one of whose sides is very nearly 61.3 ft. long. There are two wash out holes in the bottom of the boiler, about 8 ins. in diameter, one placed about 21 ins. from the throat sheet seam and the other about 24 ins. back of the front flue sheet.

The smoke box, which is without cinder hoppers, is not exactly what is called an extension front end, though it is quite as large as many of the extension boxes which stand farther out. The lagging is extended up to the smoke box course proper, but the smoke box itself extends back about 24 ins. from the row of smoke box rivets next

Wheels, etc.—Diam. of driving wheels outside of tire, 75 ins.; diam. and length of driving journals, 9 $\frac{1}{2}$ ins. dia. x 12 ins.; dia. and length of main crank pin journals (main side 7 $\frac{1}{2}$ ins. x 4 $\frac{1}{2}$ ins., 17 ins. dia. x 6 $\frac{1}{2}$ ins.; dia. and length of side rod crank pin journals, F&B 5 ins. x 4 $\frac{1}{2}$ ins.

Boiler—Working pressure, 200 lbs.; thickness of plates in barrel and outside of fire box, $\frac{1}{2}$, $\frac{3}{8}$, $\frac{3}{4}$, and 1 in.; fire box, length, 96 $\frac{1}{2}$ ins.; fire box width, 75 $\frac{1}{2}$ ins.; fire box depth, front, 79 $\frac{1}{2}$ ins.; back, 64 $\frac{1}{2}$ ins.; fire box plates thickness, sides, $\frac{3}{8}$ in.; back, $\frac{3}{8}$ in.; crown, $\frac{3}{8}$ in.; tube sheet, $\frac{1}{2}$ in.; fire box, water space, front, 4 $\frac{1}{2}$ ins.; sides, 4 $\frac{1}{2}$ ins.; back, 4 $\frac{1}{2}$ ins.; grate surface 50.23 sq. ft.

Tender—Style, water bottom; weight, empty, 52,400 lbs.; wheel base, 16 ft. 9 $\frac{1}{2}$ ins.; tender frame, 10 in. channels; tender trucks, Fox pressed steel; water capacity, 6,000 U. S. gallons; coal capacity, 10 tons.

Ratios—Heat, sur. to cyl. vol. = 328.4; tractive Wt. to heat sur., 37.4; tractive effort to heat sur., 7.58; heat sur. to grate area, 74.5; total Wt. to heat sur., 58.2.

A man wishing to get on in the world should conceive himself to be a wedge watching for any opportunity to insert himself.

Railway and Locomotive Engineering

A Practical Journal of Railway Motive Power and Rolling Stock.

Published Monthly by

ANGUS SINCLAIR CO.,

174 Broadway, New York.

Telephone, 984 Cortlandt.

Cable Address, "Loceng," N. Y.
Glasgow, "Locanto."

Business Department:

ANGUS SINCLAIR, President.

FRED M. NELLIS, Vice-President.

JAMES R. PATERSON, Sec'y and Treas.

Editorial Department:

ANGUS SINCLAIR, Editor.

F. M. NELLIS,

GEO. S. HODGINS,

JOS. A. BAKER,

Associate Editors.

Advertising Department:

Eastern Representative, S. I. CARPENTER, 170 Summer St., Boston, Mass.

Western Representative, C. J. LUCK,

1204 Monadnock Block, Chicago, Ill.

British Representative:

THE LOCOMOTIVE PUBLISHING CO., Ltd., Amen Corner, Paternoster Row, E. C., London.

Glasgow Representative:

A. F. SINCLAIR, 7 Walmer Terrace,

Ibrox, Glasgow.

SUBSCRIPTION PRICE.

\$2.00 per year, \$1.00 for six months, postage paid to the United States, Canada and Mexico. For other parts of the world, \$2.50 or ten shillings. Single copies, 20 cents. Remit by Express Money Order, Draft, Post Office Order or Registered Letter. Mailing address can be changed as often as necessary—always give old and new address, and if you subscribed in a club, state who got it up. Please give prompt notice when your paper fails to reach you properly.

Entered at Post Office, New York, as Second-class mail matter.

Copyright by Angus Sinclair Co., 1904.

For Sale by Newsdealers Everywhere.

The Railroad Shop Apprentice.

The railroad shop apprentice does not look like a very important person as he stands beside an old fashioned drill press in some dark corner of the shop, and by himself individually he is not an important person. His position, or rather his status in the shop is nevertheless a very good index of the policy of the shop managers and in proportion as he is encouraged or neglected so the enlightened views of his superiors, or the reverse, are made manifest.

The apprentice has been described as the raw material out of which mechanics and artisans are made, but he is usually more than that, he is in a certain sense a volunteer because, at a teachable age, he comes forward, anxious to learn. Barring the heedlessness of youth, he will advance under leadership, but will make but slow progress under a system of driving.

Since the apprentice requires teaching and opportunity, and as a railway company is primarily concerned with the transportation business for profit and is only incidentally interested in the apprentice, to make matters fair there must be a bargain between the

two by which mutual benefit may be derived. There must be a quid pro quo on each side. The apprentice receives instruction and is given employment at a nominal figure, and at the outset the railway does not reap much benefit. During, perhaps, the last two years of his term, if he be an intelligent and industrious youth, it is probable that the railway company could not replace him for the money paid.

The apprenticeship system in vogue on the Grand Trunk Railway as outlined in a paper read by Mr. Robert Patterson before the Canadian Railway Club, is framed with an eye to the mutual advantages and obligations which are to be derived, and which bind both parties to the contract. The selection of candidates is carefully done with a view to permanent employment. A good system may be rendered useless and barren of results if that enemy of all safe and economical railroad operation—laxity in discipline—be allowed to creep in. Without official sanction some foremen, disregarding the rights of the apprentice, will try to keep a bright boy on a particular kind of work longer than he should be kept at it, because his aptitude, developed to the point of excellence, means cheap production for the shop. Cheap work so obtained is not a legitimate shop economy, but is rather an abuse of, and not a fault pertaining to, the apprenticeship system.

There is always an influence at work more or less successfully which tends to create misunderstandings between the apprentice and the company he serves. In proportion as this influence is successful the real progress of the apprentice suffers. The apprentice is generally influenced by the behavior and the talk of the older mechanics in the shop. Some of these have not had the advantages which are now offered to the younger men and there is often an impression created in the mind of the apprentice that the company is seemingly using him fairly at the outset but with an ulterior motive behind it all. These older men wish to make the beginner believe that pay and not experience is what he should strive for.

The Grand Trunk apprenticeship system aims to restrain the unfair foreman and to counteract mischief making influences in the shop. It places a youth, for he should be about seventeen or eighteen years of age, first on a drilling machine when he comes from other shops to the machine shop. He is expected, however, to pass a preliminary examination in which some general questions known beforehand, are asked concerning the tool he is to operate. A half sized drawing of a crank pin for a mogul engine is required to be made by the apprentice. After three or four months on a drill,

he goes to a shaper or planer after having passed an examination on those tools, the question which will be asked being known beforehand and he makes another drawing. After six or seven months' work on these tools he is advanced to a lathe after again having passed the prescribed examination and made the required drawing. When about eighteen months have been spent on lathes he is examined concerning vice fitting and makes a more advanced drawing, and is promoted to the "bench."

When doing vise work he spends about three months on motion work, then three months on main and side rods, after which three months is occupied on driving boxes, and he finishes the rest of his time in the erecting shop. Here he works perhaps three months with the steam pipe gang, three months in the valve gang, three months in the slide bar gang, after which he is put to general work, where he gets a general knowledge of the locomotive, its construction, and repairs.

The advantages claimed for the examinations is that a young man gets a theoretical knowledge of the various machines he will work on, before he tries his hand on them, and that, together with the instruction he receives from his foreman or the charge hand will enable him to make a much better start than he otherwise could make. The questions being known beforehand, he is encouraged to pick up the necessary information and be thoughtful and observing.

In the matter of wages we may say that the Baldwin Works pay apprentices of the first, or junior class, 5, 7, 9, and 11 cents per hour for the first, second, third and fourth years respectively. Apprentices of the second class, whose term is three years, get 7, 9 and 11 cents per hour for the first, second and third years, and apprentices of the third, or two-year class get 13 cents for first half and 16 cents for the second half of the first year, and 18 cents for the first half and 20 cents for the second half of the second year. The three classes of apprentices differ generally speaking in age and in educational qualifications both actual and prospective. On graduation apprentices of the first class receive the sum of \$125.00, and those of the second class \$100.00.

There is one feature of the apprenticeship system, which no railroad shop can afford to ignore and that is that on completion of the term of apprenticeship, the graduate should not only be eligible for, but should be at once paid journeyman's wages. If the apprentice has been bound by a legal agreement he has worked steadily in the shop where he began, untempted by offers of higher pay elsewhere when he has become proficient in some particular

line of work, before his full term had expired. The finished apprentice has become a workman and is entitled to the treatment accorded to a skilled artificer, otherwise a company runs the chance of carefully training men for other people to employ.

The Lubrication of Locomotive Valves and Cylinders.

"The piston valve has simply transferred the worry about lubrication from the engineer to the stockholder," said Mr. D. R. McBean, master mechanic on the Michigan Central, in an admirable paper on the subject of lubrication recently read before the Western Railway Club. The writer of the paper explained his meaning by saying that the piston valve has taken from the engineer much of the annoyance experienced with the slide valve, the two principal causes of annoyance with the slide valve when dry being the noise made by the reverse lever, and the jerking which takes place when the cut-off is changed. The piston valve, when it gets dry, or even very dry, does not rattle or jerk, and though this relieves the engineer from annoyance and physical effort yet it costs the railroad companies hard cash in the matter of wear and tear and coal consumption. Drops per minute mean nothing unless work performed per minute is taken into account.

Mr. McBean said he had watched the pressure carried, increase from the 140 lbs. of twenty years ago to the 220 lbs. of to-day and had noted the growing trouble in the matter of lubrication which had come with the years. He did not quite believe the contention of the lubricator men when they said that they were able to deliver oil in the steam chest under any and all conditions, because with present pressures, high speed, and short cut-off lubrication of valves and cylinders was an exceedingly difficult problem.

On long runs he believed that either the throttle must be eased off frequently so that steam chest pressure will be reduced considerably below the boiler pressure, or the engine must be run with longer cut-off and throttle opening such that it will keep the steam chest pressure low enough to permit the lubricator to feed oil satisfactorily when the engine is working.

Long cut-off and short throttle has become the most accepted method among engineers, and this fact, Mr. McBean thinks, is responsible, in a large measure, for the increase of fuel consumption that has been well nigh universal. If engineers would see that valves and cylinders are properly oiled before starting out, and that no more water than can be helped, is worked over the valve seats and through the cylinders

no difficulty would be experienced in keeping the rubbing surfaces fairly well lubricated even with a wide open throttle, if the throttle is eased off, for a moment, very fine, say every five to eight miles.

Leaky Rod Packing.

To judge from the clouds of steam that have been seen all winter beclouding the front of the locomotives on even the best and fastest trains, we are convinced that the piston and valve stem packing form one of the weakest and most troublesome things about the engine. The intense pressure of steam carried puts very great stresses upon packing and much care and vigilance are necessary to prevent escape of steam, but we think the difficulty is not too great to be overcome if the proper means for doing so are observed. What makes us believe that the evil is not beyond remedy is the fact that some roads are comparatively free from blowing glands, while others having the same kind of packing seldom have the glands tight.

When injectors and air brakes first came into use there was much trouble experienced in keeping them in proper working order, whereas, nowadays no kind of hand worked mechanism gives less trouble. The cause of the change is that the practice has become general of having repairs in injectors and on air brakes done by men who are experts in the care of that kind of mechanism. Gland packing is still regarded of such a simple character that any machinist is considered equal to the work of repairing it or of putting in new rings properly. This is where a bad mistake is made. Special skill and care are just as necessary in fitting up rod packing as they are necessary on other mechanical lines.

On investigating the cause of some railroads avoiding the annoyance from rod packing constantly getting out of order, we find that on such roads the packing is under the care of specialists whose experience teaches them the weak points that must have constant care and the nursing necessary. Locomotives that are running in front of trains in a cloud of steam proclaim that they are suffering from inferior repair shop management.

Comparison of Accidents in Two Countries.

Apropos of the letter written by Mr. Slason Thompson, of Chicago, which appears in another column, we clip the following from the *Literary Digest* of March 12, 1904.

RAILWAY ACCIDENTS: A REPLY.

"Mr. S. C. Thompson, one of our readers, regards as faulty the logic of *The*

Railway Age in its interesting comparison of railway accidents in America and Great Britain, considered in these columns February 6 (p. 167). He says:

"The railway organ, in its article, coolly multiplies the English casualties by nine on the astounding assumption that danger and difficulty are in proportion to length of roads; whereas everybody knows that liability to accident is increased with density and congestion of traffic. If there were nine times as many passengers, or if the average of all the journeys were nine times as great in America there would be some logical basis to the claim. In fact, mileage is relatively a small matter; for the overwhelming bulk of traffic in America, as in other countries, is around the great cities and densely populated districts—made up of short journeys. To illustrate the logic of the article, let us say that, roughly speaking, in population England is to the United States about as New York city is to the State of New York. Suppose that in ten miles of Broadway ten men were killed in a year. Then take Broadway continued a hundred and fifty miles up the State. On that road we ought to expect that there would be killed a hundred and fifty men, because, forsooth, it is fifteen times as long. Now we know, as a matter of fact, there would probably be nobody killed outside the city, for the double reason of fewer people to be killed and almost no chances of accident from crowding."

"It has at times been claimed that dense railway traffic, like that in England, is really more safe than that in America, because where traffic is thin, receipts and profits are thin, and the expensive improvements necessary to safety are not made."

Pensions for War Time Locomotive Engineers.

A bill has been introduced into Congress by Representative Wiley, of New Jersey, to make men who served as locomotive engineers during the civil war eligible to receive pensions. We believe that the pension business has been greatly overdone and that thousands of people are enjoying the nation's bounty for war services who never ran any personal jeopardy or passed through any hardships in the service of the country; but if any extension of the pension list is going to be made the locomotive engineers ought certainly to receive consideration. Taking them as individuals the men who ran locomotives for military purposes performed much more valuable services to the country than any single combatant, and they incurred even more danger than the average soldier besides often enduring intense hardship, and they were always like officers on duty burdened

with responsibilities that never touched the ordinary soldier. There would be no difficulty in making out a good case for war time locomotive engineers receiving pensions so long as pensions are in order.

Not Taught.

We are told in a very readable paper by the general claim agent of the St. Louis Terminal Railway Association, on the "Making of a Railroad Man," that a certain master mechanic when talking of compressed air as a motive power for vehicles, suggested that by a suitable arrangement of pumps on the axle, the mechanism, after having its reservoirs duly charged could, by its own motion keep up the supply under pressure, indefinitely. The writer, Mr. S. D. Webster, says that he remarked that the day of perpetual motion had not yet dawned and switched the conversation to another topic.

All through the paper, which gives the old fashioned, and in some places, the still practised method of picking up and of working railroad men, the lack of systematic training is well brought out. In fact "not taught" might almost be the official epitaph written concerning the careers of many men who have got on and have held important positions in the railway world.

In speaking of the old way in which a fireman was developed and eventually became an engineer the writer says that in all this man's novitiate no one took the trouble or the care to explain the why or the wherefore of anything whatever. He simply learned in a routine way to imitate what he saw done and that many of the old school of master mechanics held that "the less he knew about the machine the better engineer."

An amusing case of a division superintendent is given, who on looking over a set of papers regarding a serious claim for damage replied, "Car handled carefully and no damage done on this division." The papers came back with an inquiry as to how this could be the case when his own previous report had stated the car had been smashed to splinters. "This man's mental habits had not kept pace with his promotion," and he put all the papers into the stove. The investigation had to be begun all over again by the company with a handicap in the shape of the loss of several original letters.

Mr. Webster's picture of the days that were accounts for some railroad Topsyis who just "grewed," before the advent of the instructor, or of the school car. One thing which helped railroad matters forward was what he calls the narrow gauge craze. At first the advocates of the narrow gauge knocked out the theories of the standard gauge men, but it made the latter, think. They were compelled to

see that if half or two-thirds of the material in a standard gauge car, put into a narrow gauge car of better design and proportions, could be made to carry as great a load as the standard car carried, then the possibility of rearranging their proportions, and of doubling car capacity without increasing the dead weight dawned on the standard gauge people.

This caused car builders to break away from the routine or simply imitative method in car construction and the same idea carried out in other departments caused further development in the construction of engines and of permanent way. The railroad of to-day is the result of evolution. Everything in, on, or about it has changed from what it was at the beginning. Possibly the fittest has survived, but nothing came to us fully developed. Change has been the order of the day, progress or decay have been the alternatives.

Instead of the haphazard "rule of thumb" idea in training railroad men, our progress has been largely due to intelligence, natural as well as that acquired by experience supplemented by the wisdom contained in books; gleanings from the experiences of many, garnered and winnowed, until the chaff has been cleared away and the sound wheat only left for bread of the kind that hunger craves; the bread of an intelligent understanding of how best to do the things which those employing wish done.

Train Orders.

The North-West Railroad Club which is noted for the sensible, practical papers introduced for the intelligent discussion of members, had up the subject of train orders lately. Mr. H. M. Eshelman, train master on the Chicago Great Western, who introduced the subject with a paper on "Train Orders, What Words Should be or Should Not be Abbreviated," took a decided stand against the practice of abbreviating words in writing out train orders; but he was willing to permit a few exceptions. He was more considerate towards the writer of train orders than we are inclined to be. The handwriting of the average telegraphic operator is none too legible at the best when words are spelled out. When he is permitted to express orders by abbreviations he introduces an unnecessary and inexcusable source of error, and, therefore, of danger. A train order cannot be too plainly written either in handwriting or in diction although both are habitually inferior.

In this connection we think that train dispatchers and division superintendents would do good service to their employers by examining orders written by operators more frequently than it is done, and raise objections to the hiero-

glyphic style of handwriting emanating from certain pencils.

One member discussing the paper expressed the belief that the time had come when all train orders should be written on a typewriter. That is an excellent idea and certainly ought to be carried out. The time will come when public opinion will compel all railroad companies to operate their lines under the block system with staff and tickets for single lines. Until that reform comes about the facilities in use ought to be made as perfect as possible. Railroad companies are not courting the introduction of the block system on thoroughly trained lines any more than they courted the introduction of other safety appliances, and the way to avoid public pressure that will compel vast expenditures for the installation of a signal system is to avoid accidents due to avoidable blunders.

Railroads Liable for Accidents Resulting from Defective Attachments.

A head brakeman of a freight train, in attempting at night to jump upon the pilot of the engine while it was moving very slowly in a newly constructed freight yard, sustained severe personal injuries. There was testimony on the trial of his suit for damages to show that in boarding the pilot the stirrup, which had long been defective, gave way, throwing the plaintiff's foot into one of the unfilled spaces between the ties, from which he could not extricate himself in time to prevent injury. The brakeman's action in jumping was in the discharge of his duties, and the only company rule on the subject warned employees not to jump on or off an engine running at a high rate of speed. It was also made to appear that the injured man was without knowledge of the defect in the stirrup or the condition of the track where he was hurt. The judge of the lower court dismissed the case, but the Supreme Court of the United States has held, in sustaining a verdict for the plaintiff, that the evidence was sufficient to demand the submission of the case to the jury.

Want Money to Ventilate the "Hammer Blow" Again.

We learn from a newspaper dispatch that Senator Quay proposes appropriating \$50,000 of the people's money to investigate the so called "hammer blow, centrifugal lift and tangential throw" of locomotive driving wheels. We are inclined to think that the attempt to have the United States Government spend money on experiments to test the hammer blow is a dead issue. Since it was first agitated through the Railway Master Mechanics' Association seventeen years ago, experiments have been

carried out which gave to the engineering world all the information needed on the matter. The parties who have so long agitated this question do not want information, they want an appropriation.

Business Openings On the U. P.

A short time ago the passenger department of the Union Pacific Railroad—"the Overland Route"—got out a very handy little folder called Business Openings on the Union Pacific. For example, it begins with Council Bluffs, Ia. On one sheet it gives information regarding this city, its population, parks, public buildings, water communication, rail connections, etc., etc. On the other page it mentions the facilities for manufacturers, especially vehicle and farm implement manufacturers. At Albion, Neb., for instance, we find that a good hotel is needed; Amherst, Neb., could take care of a small mill; Barnestone, Neb., wants a department store, and has good clay for a brick yard; wants a flour mill, and has good water power available.

A few pages further on we find that Boelus, Neb., could take hold of several diverse kinds of things—a good flour mill, a restaurant, a doctor, a creamery, and a good barber shop. Several places do not seem to require anything, and in this way the right people are directed to the right places and where an industry is not required or would not likely flourish its absence, in what we may call the "want" column of this pamphlet of 151 pages, indicates the fact. Send to Mr. E. L. Lomax, General Passenger and Transportation Agent, Union Pacific, Omaha, and see what the western country is most in need of, if you are in any way interested.

Mr. J. J. Hill on Low Cost of Freight Transportation.

In the course of evidence given before a committee of Congress Mr. J. J. Hill said:

"If a railroad could be built between Buffalo and New York," he said, "which would not be compelled to carry passengers, but should be devoted entirely to freight, I would guarantee to turn the proposed 1,000-ton barge canal into a lily pond."

He cited as an instance of cheap freight rates that are made by railroads when the volume of freight is great enough that he carried ten barrels of flour ten miles at an average cost of one cent on the way from Minnesota to Yokohama.

That is an astonishing statement. A barrel of flour weighs 196 pounds. So Mr. Hill has carried 1,960 pounds, presumably at a profit for one cent. That is equivalent to carrying 19,600 pounds, well on to ten tons, one mile for one cent.

Questions Answered

(29) L. A. B., Monett, Mo., asks:

What is the rate of speed of the fastest scheduled train in the world? A.—Probably the fastest train is the Atlantic City Express on the Philadelphia & Reading. This train runs without a stop from Camden, Pa., to Atlantic City, N. J., a distance of 55½ miles, at the speed given by Mr. G. C. Tuncell in the *Journal of Political Economy*, as 67.96 miles per hour. The fastest foreign train is given as the Méditerranée Express on the Paris, Lyons & Mediterranean, Paris to Calais, 185.14 miles, covered at the rate of 59.72 miles per hour.

(30) R. E. V., Mount Sterling, asks:

(1) Will a locomotive pull as big a load with 60 in. drivers as if it had 70 in. drivers, allowing same weight on each pair of drivers. A.—Other things being equal the larger load will be pulled by the engine with the smaller wheel. See article on The Frictional Limit, page 20, of our January, 1903, issue; in it you will find the formula for finding the tractive power of a locomotive. You will observe that in it, the diameter of the drivers is the divisor, and, as you know, the larger the divisor the smaller the quotient, and in that formula the quotient is the tractive power.

(2) Will a locomotive pull as big a load with crank pin set 12 ins. from center of axle as if it was set 15 ins. from the center of the axle. A.—Other things equal the engine with the larger stroke will pull the greater load. Refer again to the formula and you will see that the stroke is one of the factors in it which is used to multiply with, and consequently the larger the stroke the greater the tractive effort when everything else remains the same.

(31) W. G. P., Waycross, Ga., writes:

I notice on page 163 of your April number you say in describing the 2-8-0 engine for the Erie that the tender is of usual form and the tank has a water bottom; what is a water bottom? A.—In the old style U-shaped tank the coal space was so arranged that the fuel was surrounded by the leers of the tank and it rested on the deck of the tender, and the fireman shoveled from a plate only a few inches above the top of the tender frames. In a tank having a water bottom, the tank is something like the shape of a laced shoe. Part of the tank extends under the fuel and part behind it, and it is this flat extension, perhaps 14 or 18 inches deep, which is under the coal, that is called a water bottom. In this style of tank there is generally no water space at each side of the fuel, the lines of rivets on the outside of such a tank reveals its internal construction.

(32) J. J. G. F., Caldwell Pa., writes:

Mr. G. and I had an argument about a vertical dry head boiler. Mr. G. claims that the tube surface which is surrounded with steam, does not help in any way to make pressure, but is an injury and that this part of the boiler dries away the steam to nothing. He also says that steam cannot be made more expansive by the addition of more heat. He claims that instead of raising pressure the heat applied will dry up or consume it and nothing will be left. I do not agree with this. Who is right? A.—You are right. The heat from the tubes above the water line will help to dry the steam, by raising its temperature, and steam so heated will be more expansive. Heating steam in a confined space cannot dry it away to nothing. The hotter it gets the dryer and more expansive it gets, and while it remains enclosed it remains in the gaseous form we call steam.

(33) J. S. B., Selma, Ala., asks:

What is the best method to tell when wedges should be set up on the new class of engines where the wedges are on the forward side of the boxes? A.—The same general rule applies to this case as to others. In order to set up your wedges you must move the box away from the wedge. In this case steam must be admitted into the cylinder so as to carry the boxes having lost motion back against the solid shoes. Then the wedges can be set up. When the wedges are on the rear side of the boxes the boxes have to be drawn away from the wedges in order to set up the wedges.

(34) C. J. K., Columbus, O., writes:

(1) Please give an easy method of distinguishing iron from steel. A.—Use nitric acid. If a polished article is treated to a coating of nitric acid and retains its lustre, it is iron. If the acid produces a dark spot, it is steel. The harder the steel the darker will be the spot.

(2) How may I know the quality of iron? A.—If in fracturing the specimen, it shows long silky fibres of leaden gray color, it is tough, soft iron. If short blackish fibre, it is badly refined iron. If very fine grain it is a hard steely iron. If a coarse grain with brilliant crystallized fracture and brown or yellow spots, it is a brittle iron, easily worked and welded. Good iron heats readily, is soft under the hammer and throws out few sparks. The harder the iron the greater the amount of carbon in it. All iron contains some carbon.

(35) H. W. B., Cumberland, Md., writes:

How can I find the mean effective pressure in a cylinder, at different points of cut-off so as to calculate the horse power without the use of an indicator? A.—Where an indicator is not available

the rule here given will be found nearly correct. Multiply the boiler pressure by the following decimal corresponding to the cut-off.

For $\frac{1}{4}$ cut-off multiply boiler pressure by	.597
" $\frac{1}{3}$ " " " " " "	.670
" $\frac{1}{2}$ " " " " " "	.743
" $\frac{5}{8}$ " " " " " "	.847
" $\frac{3}{4}$ " " " " " "	.917
" $\frac{7}{8}$ " " " " " "	.937
" $\frac{3}{4}$ " " " " " "	.966
" $\frac{7}{8}$ " " " " " "	.992

(36) C. W. C., Indianapolis, writes:

Please give a rule to find the speed of pulleys. A.—Multiply the diameter of the driving wheel by the number of revolutions it makes and divide the product by the diameter of the driven pulley. A loose belt will reduce the speed somewhat due to slip.

(37) Engineer, Boone, Ia., asks:

What is the matter with this injector? We open priming valve and get no water at overflow. Open throttle and steam will pass back into tank but can get no water at overflow. Monitor Injector No. 10? A.—The trouble you refer to may be caused in various ways. A disconnected and closed tank valve or a loose lining in the water hose which collapses when the primer is started, this would prevent the water raising to the injector after a vacuum had been established in the feed pipe, while a leaky joint between the injector and the feed pipe would prevent the obtaining of any vacuum. The feed pipe might be filled with hot water from a leaky injector throttle. Then again, the heater valve may have been closed accidentally or there may have been an obstruction in the combining tube, forcing the steam back in the tender. A vacuum must first be established to bring the water to the overflow pipe, before the throttle can be made effective in drawing the water from the tender and forcing it into the boiler.

(38) K. H., Ithaca, N. Y., asks:

Are there any good methods which have been experimented with to prevent ice forming in the outlet of the sand pipe with pneumatic sanders? A.—There is nothing which has, so far, been brought out in this line which will prevent the formation of ice at the mouth of the sand pipes.

(39) C. W. K., Dubuque, Ia., writes:

How can I get a ten-wheel engine in tram that is cutting front and back flanges? A.—Get the side that is cutting on center, loosen rods and caliper between the top frame and rim of wheel center of main driving wheel. Square the wheel with frame by using liners in shoe and wedge, plug the small recess in center of axle with lead and locate the centers to tram by; line front and back wheel same distance from main wheel to correspond with the good side if rods key on, but if solid rods are used get lengths from them.

(40) J. C. K., Council Bluffs, writes:

What is meant by transmission bar? I have been told by some engineers that it is another name for reach rod, is that correct? A.—No. It is the bar or rod conveying the motion from the links to the valve rod direct, or in our older types of indirect motion engines from the links to the lower rocker arm. Its object in the latter case was to overcome excessively long eccentric blades and valve rods, which often caused uneven steam distribution, due to vibration or defective and insufficient lubrication.

(41) B. R. T., Perry, Ia., writes:

(1) We have an engine here cutting her tire only at one point on the flange and not around the complete circle. Will you please give the cause, as there is a difference of opinion here? A.—You have a sprung axle, probably caused by a hot bearing at some previous time.

(2) Would it show as rapidly on a wheel with a 56 ins. center as one with an 82 ins. center? A.—No, since the difference found by measuring between wheels at top and bottom would not be as great with the smaller wheel as with

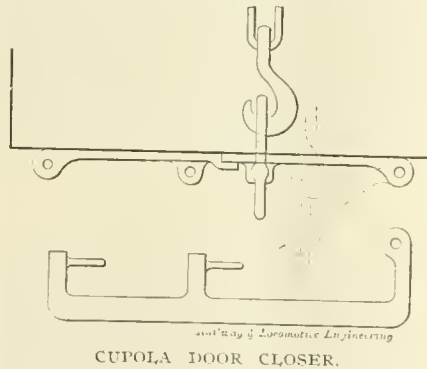

the larger one with this particular axle you refer to.

Apparatus Used in Shutting Bottom Doors of Cupola.

The foundry of the Philadelphia & Reading Railroad, situated at Reading, Pa., is a very completely furnished department of their extensive railway repair plant. There is among other appliances to be seen there what may be called a cupola door closer, which is as convenient as it is ingenious. Everybody knows that the bottom doors of a foundry cupola are not easy to close, because they are heavy and are necessarily in the most awkward position to work with, because the attraction of gravity—always against a lift—is, in the case of cupola doors, able to do its worst when the door is just in position and while the strut which holds it up is being put in place.

Mr. R. Atkinson, the master mechanic, has devised a very effective and rapid method of practically giving gravity the go by, when the doors have to be shut. It consists of an iron bar,

forged as shown in the illustration. At one end of a long neck there is an eye which engages with the hook of an air hoist, which stands near by and serves two cupolas. When the doors hang down, the bar, with the two pivot pins, like the hinges of a window shutter, is placed so that the pivot pins are well in the two holes which are cored in the lugs on the under side of each of the doors. In this position the backbone of the bar lies close up to the door while the long neck with the eye for the hoist hook, is in a vertical position. As soon as the hoist begins to lift, a door comes up, while the lifting bar remains parallel to its former position and the strut is placed. The two pivot pins turn in the lugs of the door as the latter swings up into position and is held there while the strut is adjusted. Time and labor is saved and there is never any wear out to the apparatus. When the first door is up, the second follows with little or no loss of time.

His First Experience.

An amusing story, originally told of a Scotch Highlander, is served up in somewhat novel guise in one of the daily papers. It is ascribed to a mountaineer, in Kentucky, but the main incidents remain the same. The young man, who is the hero of the tale, had never seen a railroad train. One day he consented to go to town and see the great wonder. He arrived a little ahead of train time, and, getting impatient as he waited, he walked up the track to meet it. Turning about, the mountaineer ran along the track as for his life. "Toot, toot," shrieked the locomotive, slowing up; but the mountaineer only ran faster. He reached the station, completely out of breath. "Why didn't you cut across?" inquired one of the bystanders. "Cut across!" exclaimed the uncouth youth. "If I had struck the ploughed ground the thing would have caught me."

All Trains Electric Lighted.

The Chicago & Alton Railway was the first line to run Pullman sleeping cars, dining cars and chair cars. The C. & A. was also the first line to establish a modern surgical system and the first, and so far the only line, to equip all of its locomotives with electric headlights. This leading thoroughness is to be immediately supplemented by the equipment of all cars in all trains with electric lights. Mr. C. A. Goodnow, the "Alton's" new general manager, has ever been regarded as the exponent of electric lighted trains, and has selected for the "Alton" a system by which the current is to be produced by the modern method of a dynamo driven by the axle during the run of the train.

Air Brake Department.

CONDUCTED BY F. M. NELLIS.

Air Brake Association Convention.

The eleventh annual convention of the association will be held in Buffalo, N. Y., headquarters being at the Hotel Niagara, beginning May 10, 1904. The Committee on Arrangements has made suitable arrangements for the members' convenience and their entertainment; also facilities for inventors and supply men have been furnished for the exploitation of their devices. The meeting will be called to order at 9 A. M. by President E. G. Desoc.

The Air Brake Association.

Fourteen years ago a small group of air brake men gathered in the Westinghouse Air Brake Co.'s instruction car in St. Louis, Mo., to discuss air brakes. These men were representative air brake men of the New England roads on a tour

partments. So great has been the progress of the Association in this work that the air brake service to-day stands prominently out in its efficiency when compared with other branches of railway work. The work of the Association has had the co-operation of the Master Car Builders' and the Master Mechanics' Associations. Air brake matters of importance are now generally referred to the Air Brake Association by these two large bodies before they are finally passed upon.

Although the Association has done much creditable work, there still remains ahead of it a great deal more. This work must be approached with caution and discretion. In the earlier days the Association merely introduced ideas and practices, and the larger associations took them up, and after discussing them, made their own disposal of same. To-

ing piston, the end of which is made to grip triple valve piston. G is a belt from counter shaft, driving shaft D. H is the belt which drives shaft A.

In these days of high speed trains, the importance of keeping the triple

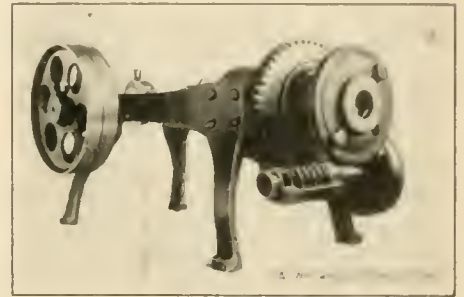

VIEW OF MACHINE FOR GRINDING PACKING RING INTO TRIPLE VALVE.

valve in good condition cannot be over-estimated. The defective triple valve piston ring is responsible for a great many flat wheels and for the pulling out of a great many draw heads. It is therefore, economy to keep triple valve packing rings in first class condition.

In making this machine we have studied to affect the work by doing it good, quick and cheap. We are using four of these machines in the A. T. & S. F. shops, located at San Bernardino, California. One boy operates all four machines, with an output of 65 to 70 triples in ten hours; whereas, the mechanic working at the vise, following the old method, cannot turn out to exceed eight or ten triples per day.

It will be observed by the construc-

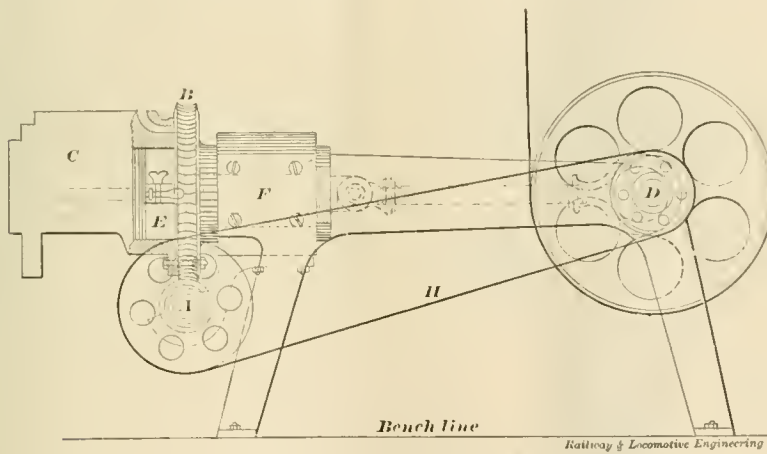

SKETCH OF TRIPLE PISTON RING GRINDING MACHINE.

to inspect western air brake practice, and men from the roads adjacent to St. Louis. So great was the benefit to all from the discussion that it was unanimously conceded that such meetings should be perpetuated, but perhaps in modified and more permanent form. The outcome of this meeting was a letter was written to RAILWAY AND LOCOMOTIVE ENGINEERING suggesting that a meeting be called in Pittsburgh to form an air brake association. About a dozen prominent air brake men responded to the call, and here the air brake association was born.

The first convention of the permanently organized body was held in Columbus, Ohio, in 1892. The succeeding conventions are familiar to all air brake men, also the substantial progress since made by the association is equally familiar to all railroad men in the mechanical de-

day, the larger associations usually pass air brake matters of major importance up to the Air Brake Association for its consideration before the subject is finally disposed of. Hence the necessity for the exercise of unusual caution and discretion on the part of the Air Brake Association.

CORRESPONDENCE.

Triple Piston Ring Grinding Machine.

I submit for publication in LOCOMOTIVE ENGINEERING a photograph and blue-print of a machine for grinding triple valve piston rings. A is a worm shaft. B is a worm gear. C is where a triple valve is bolted to face of worm gear. D is a shaft carrying eccentric and two pulleys. E is the triple valve piston ring chamber. F is an oscillat-

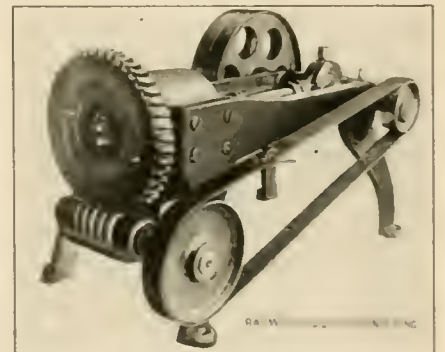

ANOTHER VIEW OF MACHINE FOR GRINDING PACKING RING INTO TRIPLE VALVE.

tion of this machine that a different portion of the piston chamber is presented to any given section of the piston ring at each reciprocation thereof. The body of the triple receives a re-

volving motion, while the piston ring receives a reciprocating motion, thereby making it a perfect fit, and preventing any leakage of air when the piston and chamber are in actual use.

It will be observed that as soon as an operator has secured the parts in position, he can start the machine in motion, and thereafter, until the piston chamber and ring is ground, it needs no further attention. He may take charge of and attend to several such machines or do other work. It requires from 20 to 30 minutes to grind the ring on this machine, while grinding the ring by hand it requires from one to three hours.

J. B. PHILLIPS,
Shop Foreman, A. T. & S. F. Ry.
San Bernardino, Cal.

Better Method of Stenciling Brakes.

I would like to call attention to the usual method of stenciling brake cylinders and auxiliary reservoirs after the triple valve and brake cylinder have been overhauled and tested. The practice now prevailing seems to have grown up from the early days without much direction or especial care.

Usually, the greater part of the auxiliary reservoir and brake cylinder, where this stenciling should be done, is occupied by raised, cast letters, advising that these parts are for freight cars and also advising that they were manufactured by a certain brake company. This information is not of any assistance and is not desired or required by the air brake man who cares for brakes. After the auxiliary reservoir and brake cylinder are once under the car, that ends it so far as the air brake inspector and repair man goes. He does not care whether the brakes were made in Hong Kong or Chelsea, or whether they are intended for a passenger engine or a caboose car. The fact that the brakes are under this car is generally self evidence that they are adapted for service on that vehicle. I cite this to show that these raised letters cast on the auxiliary reservoirs and brake cylinders are entirely superfluous for air brake maintenance purposes, and occupy space which could be otherwise better employed in maintaining air brakes.

I would suggest that these raised letters be omitted in the future construction of air brakes, or, if the brake companies desire to place the date marks of manufacture thereon, they do it with much smaller letters, and locate them in a place which will not interfere with air brake repair men's work. This space would then be clear and would give him a good surface on which to place his date marks.

I would further suggest that the place of cleaning, and perhaps the initial of the cleaner be placed along with the

date marks of the cleaning and testing done. This would fix the responsibility of cleaning on a certain place and would also make the place as well as the individual responsible for the quality of work done. I believe this would be especially valuable when we remember that quite a lot of stenciling is now going on and which indicates work performed which was not honestly done. I believe such a change would be to the advantage of the air brake maintenance in general, and I make these suggestions for what they may be worth to air brake men.

Boston, Mass.

AMOS JUDD.

The New York Compensating Valve.

The article on the New York Compensating Valve which appeared in the March issue of RAILWAY AND LOCOMOTIVE ENGINEERING deals with the valve in connection with the New York quick action triple valve alone.

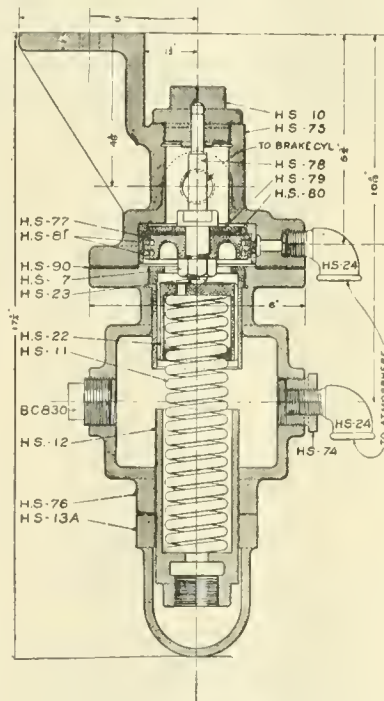

FIG. 1, COMPENSATING VALVE.

Since the appearance of this article questions have been asked concerning whether the compensating valve could be used with the plain triple valve or not. In Fig. 1 of this article we show the compensating valve as used with a plain triple.

Comparing this view with that of Fig. 4, March number, it will be noticed that the non-return check valve is not necessary with the plain triple, and that a reducer and street ell is used in its stead.

When the compensating valve is used with the plain, or any style triple, except the New York quick action, no train pipe air is vented into the spring box chamber, and there is no air pressure in emergency applications added to the reg-

ulating spring pressure to delay the opening of the valve. The compensating valve will then operate like an ordinary safety valve, except that in emergency applications the full equalized brake cylinder pressure, about, will be had from a reservoir pressure of 110 pounds.

Ordinarily, safety valve, or pressure reducing valves, in emergency applications, while the pressure is going upward in the cylinder, open before the maximum equalized pressure is obtained. This early opening tends to rob the cylinder of air, and to give a lower maximum brake cylinder pressure than would be obtainable if the valve did not open until after the auxiliary and brake cylinder equalized.

By reference to Fig. 3, March number, it will be seen that the opening through the union stud through which the air passes into the chamber above the piston, is considerably restricted so that in service applications it will provide sufficient opening for the surplus brake cylinder air to pass through to relieve the brake cylinder of over pressure, while in emergency applications the equalization between the auxiliary reservoir and the brake cylinder being so quick, the highest pressure obtainable in the brake cylinder, about, will be had. This is because the increased volume of air cannot escape before the full equalized pressure, about, has been obtained in the brake cylinder. After the full equalized brake cylinder pressure has been obtained, the valve will then relieve the cylinder in the ordinary way, blowing down to the point of adjustment.

Having had some experience with the compensating valve, it may be of interest to the readers of RAILWAY AND LOCOMOTIVE ENGINEERING to know some of the troubles which may possibly occur, due to the wear of the valve.

Referring to Fig. 1, if stem H. S. 23, which forms a guide for the piston H. S. 10, should bind in the cap nut H. S. 75, so that the latter cannot cock or bind in its cylinder, the piston would not move so smoothly as it should in its cylinder, and the relief ports would not open promptly.

The point concerning this to be observed by repair men is, in reassembling after the cap nut and piston have been removed from the body of the valve for cleaning or repairs, see that the stem works freely in the cap nut.

The leather washer H.S. 80, if cut a little too large in diameter may partially reduce the annular space between the piston and the bushing, tending to restrict the relief ports, and thus retard somewhat the escape of surplus air from the brake cylinder. Care should be had in renewing the leather washers to see that they are cut the exact diameter of the top of the piston, or a little less if anything.

The upper metal packing ring H.S. 81, covering the relief ports in the bushing, together with the leather washer constitute a double control of the relief ports making leakage from the brake cylinder almost impossible.

However, should it ever be necessary to renew the upper packing ring care should be taken in grinding it in to make it a practically air tight ring, so that when the valve starts to open air from the brake cylinder cannot leak past it in excessive quantities.

The lower metal packing ring H.S. 81, controls the leakage ports b (see Fig. 5, March number), and like the upper ring it should be a practically air tight fit, since it forms the dividing line between the spring box chamber and the atmosphere. In emergency applications, with the New York quick action triple valve, this ring should retain the air vented into the spring box chamber allowing no leakage except as the vented air backs out through the small port J, in the non-return check valve, shown in Fig. 4, March number.

As the total travel of the piston is something less than the width of a single packing ring, when the piston is at its extreme lower traverse, the leakage ports b come opposite the annular groove in the piston, between the two packing rings, and this groove and the ports provide sufficient outlet for the air that may leak by the upper packing ring to get to the atmosphere.

The leakage ports b do not influence the action of the valve perceptibly, they simply carry away the air that may leak past the upper metal packing ring, thus preventing it from getting down into the spring box chamber, under the piston.

The gasket H.S. 90 makes an air tight joint between the body and the spring box; the bolts that join these two sections together, therefore, should be drawn tight so that there will be no leakage at this point from the spring box chamber.

(Continued on page 236.)

QUESTIONS AND ANSWERS

ON THE AIR BRAKE.

(31) G. W. K., Washington, D. C., asks:

Will leaky rings in the main valve affect the speed of the pump? A.—If these rings leak badly enough, the pump will run slower.

(32) J. H. M., Philipsburg, Pa., asks:

Why are the small grooves around the supply valve piston of the slide valve feed valve? A.—These grooves hold oil or other lubricant, thereby making a good packing to separate the air pressures on both sides of the piston.

(33) J. H. M., Philipsburg, Pa., asks:

Is there any way to tell the difference between a blow around the reversing piston of the 8 in. air pump and a blow past the top end of the reversing valve rod, as they both blow on the up stroke? A.—These blows are both alike, and cannot be distinguished unless you stop one and note whether the other blows.

(34) J. H. M., Philipsburg, Pa., asks:

How should a test be made for blows past packing rings in the steam cylinder of an air pump? A.—Disconnect the discharge pipe from the steam cylinder and note whether there is a strong blow of steam pressure at that point when live steam is being admitted to the steam cylinder of the pump. If this happens, the main piston rings are leaking. If the blow is shorter and lighter, it probably comes from the reversing piston, the reversing slide valve rod or the reversing slide valve.

(35) J. Y. R., Magnolia, Va., asks:

Will you please inform me where I can get instructions for designing locomotive cam driver brakes? A.—This method is a very difficult and lengthy one and is really more trouble to master than it is worth. The cam driver brake is out of date, and none of the brake companies now use it, preferring the much more efficient outside equalized type. If you merely wish to know the braking power exerted by a cam system of brakes on one of your engines, you can get it by consulting any of the air brake books, and looking up Wahlert's rule.

(36) G. W. K., Washington, D. C., asks:

What is wrong with the pump that will not run over 50 or 60 strokes per minute at any air pressure, or with an angle cock open, until after the steam gauge registers 150 lbs. After that it can pump up to 120 lbs. pressure with the same speed as any other pump? A.—Undoubtedly your steam cylinder is worn quite badly, and allows a loss of steam which results in a decreased speed of the air pump. This may be aggravated by too small a steam pipe to the air pump, or friction in the steam pipe due to either small opening through the governor, pump connection, throttle valve or dry pump inside of the boiler. With the higher steam pressure these drawbacks would be overcome in a degree.

(37) G. W. M., Oakland, Cal., writes:

Will an air pump use more steam doing the same work, with the air cylinder smaller than the steam cylinder, than it would if they were both the same diameter—that is, would an 8 in. pump run more economical if the air cylinder was 8 ins. in diameter instead

of 7½, against 70 lbs. of air with 150 lbs. of steam; and what would be the gain or loss by increasing the stroke of an 8x9 pump to 8x10, in both efficiency and economy? A.—It is quite probable that the air cylinder 8 ins. in diameter with a steam cylinder of the same diameter would run more economically than a pump fitted with a smaller air cylinder than steam cylinder. It would also seem that the longer stroke pump would give greater efficiency and economy than the short stroke pump, on account of the clearance being the same for both, but just what would be the exact gain or loss is problematical and could be ascertained more definitely by making actual tests. These you would be able to make as well as anyone else.

(38) J. H. M., Philipsburg, Pa., asks:

Why is the packing ring in the emergency piston of the modern passenger triple valves, and why is the small port in this same piston? A.—The packing ring and small port are in passenger triples only, and not in the freight triple. The old method of fitting the solid piston into the brushing was abandoned because the fit was not always the same, and consequently the leakage past the piston was not uniform in all triples. The ring was put in to make a more uniform fit, and the small port was put in to take care of the leakage. In this method we know at all times that the piston will be held down until the full amount of train line pressure passes to the brake cylinder in an emergency application, instead of leaking past the piston and permitting it to rise and allow the emergency valve to close before the full amount of desired train pipe pressure has passed to the brake cylinder.

(39) S. L., Newcastle, N. S. W., Australia, writes:

Will you kindly explain the law that arrests the speed of a train consisting of ten or more cars, more rapidly than the speed of a train consisting of five or less cars, each car equally loaded, each train equipped with automatic air brake and running at the same high rate of speed? A.—There is really no law, except one of proportion, controlling this movement; but the quicker stop is made with a long train. The engine has considerable unbraked weight. It will be readily seen that a larger number of cars can together hold back this unbraked weight of the locomotive more easily than can a few cars. It is the unbraked weight of the locomotive and tender which pulls the train along, and the longer train is more able to do this greater amount of work than a shorter train.

(40) B. M. J., Albany, N. Y., writes:

If the straight air brake valve is left in full release position, and you apply

the automatic brake, there is a continual blow of air brake exhaust port of the straight air brake valve, and finally the brake goes off quietly and before you know it. Why is this? A.—The leather seat on the straight air side of the double check valve in the combined automatic and straight air system is leaking, permitting brake cylinder pressure to pass through the faulty seat into the pipe of the straight air brake and out at the exhaust port of the brake valve, thus releasing the brake. This action is identical with a bad packing leather in the brake cylinder, which permits brake cylinder air to escape past it to the atmosphere.

(41) E. N., Los Angeles, Cal., writes:

Suppose we charge the train line and auxiliary reservoir to 70 lbs., then apply the brake in emergency application by letting all the air out of the train pipe, then bleed the brake off through the release valve. The auxiliary and cylinder is equalized. After auxiliary pressure is bled below the tension of the graduation spring, the triple is forced to lap position and the graduating valve is on its seat. How does the rest of the cylinder pressure get into the auxiliary to cause the brake to release? A.—The triple being in full application position creates a direct passage between the auxiliary and brake cylinder. When the release valve on the auxiliary is now opened, both auxiliary reservoir and brake cylinder pressure pass out through the release valve until the tension of the graduating spring pushes the piston and slide valve to lap position, seating the graduating valve. The auxiliary reservoir pressure, being still drawn off, reduces the pressure on the back of the slide valve until such time as the brake cylinder pressure on the under side of the slide valve overcomes the downward combined pressure of the auxiliary reservoir and spring on the slide valve, thus lifting the slide valve partially from its seat. This permits brake cylinder pressure to get to the auxiliary reservoir and out at the release valve. By this time the brake piston is on the leakage groove, and some of the final brake cylinder pressure passes out through that groove.

(42) E. N., Los Angeles, Cal., writes:

If you charge the train line and auxiliary reservoir to 70 lbs., then apply the brake in the emergency application and release through a diaphragm, and the emergency valve is a little bent, there is a discharge of air from the triple, then it stops, and then another discharge and so on. How does the air work through the triple to cause this? A.—The diaphragm acts as a partial closure, similar to the cutout cock in the crossover pipe almost closed. This practically reduces the volume of train line pressure to that

lying between the diaphragm, or cutout cock and triple valve. The bent emergency valve permits train line air to leak past it into the brake cylinder, thus reducing the train line pressure. The brake will apply, causing auxiliary reservoir pressure to pass to the brake cylinder. When the auxiliary reservoir pressure is reduced lower than the train line, by giving up its pressure to the brake cylinder, the train line pressure preponderating, will force the triple piston to release position. This applying and releasing action will last as long as the pressure is permitted to pass through the diaphragm into the train pipe, and also to pass by the bent emergency valve.

(43) M. J. F., New Haven, Conn., asks:

Why is an engine given only 75 per cent. braking power, and a tender gets 100 per cent.? If the tender is always practically loaded, isn't an engine also? A.—Practical experience has proved that 75 per cent. braking power is sufficient and the limit to which it may be placed on driving wheels of locomotives. In specifying the weight on drivers, it is meant that the weight resting on the drivers is that carried by the engine when in working order; that is, with about three gauges of water in the boiler. In reality, the braking power on the locomotive drivers is therefore figured on the basis of loaded weight, as the water very seldom varies to any considerable degree from the normal amount. Locomotive tenders and cars have their braking power figured on the light weight of the vehicle, but if the braking power was taken after the load had been placed on the vehicle, it would be found that the braking power was as low, if not lower, than 75 per cent. Again, a certain retardation is given to the engine through the medium of the pistons in the steam cylinders. On compound engines this resistance is higher, and the braking power on the drivers must therefore be figured lower than 75 per cent. to prevent skidding of wheels.

(44) B. M. J., Albany, N. Y., writes:

Why will not the combined automatic and straight air brake release when the straight air valve handle is left on lap position? One of our engines, if the straight air brake is applied and fully released, then the handle brought to lap position and the automatic brake applied, will not release when the automatic brake valve handle is put in full release and the straight air valve handle left on lap. A.—You will doubtless find that the leather seat of the double seated check valve in the automatic and straight air device on the engine is in bad order and is leaking, and permits brake cylinder air to leak past it into the straight air pipe and out at the straight air brake valve. If the

straight air valve handle is left on lap, brake cylinder air leaking past the leather seat of the double check valve will accumulate in the straight air pipe. When the automatic brake is released, the cylinder will nearly empty itself through the triple valve as usual, then, when the brake cylinder pressure is quite low, the accumulation of leakage pressure remaining in the straight air pipe, due to leakage past the double seated check, will shift the check valve to the straight air position, and empty the contents of the straight air pipe into the brake cylinder.

(45) G. W. K., Washington, D. C., writes:

If we have a short piston travel on the tender brake and a long travel on the driving brake pistons, and reduce the pressure in the train pipe to a point where it equalizes with the pressure in the driver brake cylinders, and a considerable volume of air leaks back through the check valve in the tender triple, will it release the driving brakes or lift the equalizing piston in the brake valve and escape? We will suppose that both have good rings and are properly lubricated. A. 1.—The probabilities are that the equalizing piston will first rise inasmuch that it has no slide valve whose friction must be overcome, like the triple valve has. This is supposing that both rings have the same fit, same pressure against the walls of the cylinders and the same friction. Q. 2.—How will it act if the equalizing piston ring is rather loose? A. 2.—If the equalizing piston ring is sufficiently loose to accommodate the leakage, chamber D will take the leakage and the equalizing piston will not rise. Finally, the triple piston will go to release position. Q. 3.—How will it act if both rings are rather loose? A. 3.—It will depend entirely on the degree of looseness and the amount of leakage through the non-return check of the tender brake triple with the chances that neither piston may be moved. This depends entirely on the degree of leakage past the piston rings and through the non-return check valve.

(46) G. W. K., Washington, D. C., asks:

How much pressure will an air pump with 9½ in. steam cylinder and 9¾ in. air cylinder compress with 100 lbs. of steam? A.—This will depend entirely on the condition of the rings in the air cylinder, lift of air valves, tightness of piston rod packing, etc.; in fact much will depend on the entire condition of the whole air pump. A fair average pressure would be between 80 and 90 pounds. Q. 2.—What should the piston speed be at 160 pounds steam and 120 pounds air pressure? A. 2.—About 120 to 140 single strokes per minute.

English Three-Cylinder Compound on the Midland.

Our illustration shows a three cylinder eight wheel compound express locomotive belonging to the Midland Railway of England. The engine was designed by Mr. S. W. Johnson, the locomotive superintendent of the road, and is reported to have given excellent service, working the express passenger trains on the line between Leeds and Carlisle.

The engine is a three cylinder compound, with two low pressure cylinders on the outside and one high pressure cylinder in the center below the smoke box. All pistons drive on the axle of the first pair of large wheels. The cylinders are 19 and 21x26 ins. and the diameter of the driving wheels is 84 ins.

The crank pins are set at right angles to each other, and a line through the center of the middle crank, in the axle, bisects the obtuse angle between the

the reduced pressure direct supply is thus cut off. Although the working steam pressure is 195 lbs. the result of all this is that none of the pistons are ever subjected to a pressure as high as that on the pistons of a simple engine working with 170 lbs. boiler pressure.

When working compound the pressure in the low pressure chest varies from 40 to 60 lbs. according to the position of the reverse lever. When starting or climbing a grade, the full power of the engine may be had by admitting live steam to the low pressure chest for as long a time as is required. The regulating valve can be operated from the foot plate, between minimum and maximum limits.

A piston valve is used with the high pressure cylinder, and a pair of ordinary D-slide valves, running on edge, are used in connection with the low pressure cylinders. The H.P. cylinder stands on

heating surface of an ordinary tube of the same diameter, but in practice a Serve tube one foot long is as good as an ordinary tube a foot and a half long. The use of Serve tubes is said to give about 10 per cent. greater efficiency in



SERVE TUBE, 2 1/2 INS. OUTSIDE DIAMETER, SHOWING INTERNAL PROJECTIONS.

steam making than the ordinary tube can give. The edges of the ribs do not burn off which proves that the heat



THREE-CYLINDER COMPOUND PASSENGER ENGINE FOR THE MIDLAND RAILWAY OF ENGLAND.

pins. The central high pressure cylinder takes steam direct from the boiler at a pressure of 195 lbs. and when this steam is exhausted, it goes into the low pressure steam chest, which as may be seen from our line engraving, is common to both low pressure cylinders. This form of construction does not require any large reservoir, or receiver pipe. While the admission of live steam direct to the high pressure cylinders is taking place, there is also a direct admission of steam to the low pressure chest, through a regulating or reducing valve placed in a vertical position on the side of the smoke box. Live steam at a pre-determined pressure, is thus permitted to augment the steam supplied to the low pressure cylinders from the high. When the maximum pressure allowed in the low pressure cylinders is reached, the regulating valve closes and

an incline of 1 in 40, the back cylinder being the lower one while its piston valve is inclined in the opposite direction.

The boiler is 56 ins. in diameter at the second ring and it has a level top and a Belpaire fire box. The grate area is 26 sq. ft. and the heating service with fire box and 261 copper tubes, 1 3/4 ins. in diameter and 11 ft. 7 ins. long, is 1,508 sq. ft. When Serve steel tubes 2 1/2 ins. in diameter are used with same size of fire box, viz.: 150 sq. ft., the total heating surface is then about 1,719.8 sq. ft. Engines equipped with Serve tubes were found to be quite as efficient as those having a greater number of copper tubes of smaller diameter.

The Serve steel welded tube has internal projecting ribs, as shown in our illustration. The heat absorbing surface in a Serve tube about equals twice the

transference from flue to water is exceedingly good.

The wheel base of the engine is 24 ft. 3 ins. That of the bogie is 6 ft. 6 ins. That of the tender is 16 ft. 10 ins., and the total wheel base of engine and tender is 57 ft. 8 5/8 ins. The total weight of the engine in working order is 126,561 lbs. The tank capacity is 4,500 Imperial gallons. The apparatus seen on the hand rail in our half tone illustration, is the Vacuum brake ejector.

The screw auger was invented by Thomas Garrett about the beginning of the 19th century. He lived near Oxford, Chester county, Pa. The single screw auger was invented by a Philadelphian, and it is said to be the only one used with any satisfaction in very hard woods, where the double screw augers become clogged.

How Fairness is Secured in Car Interchange.

A source of untold annoyance and vast expense to railroads, until the Master Car Builders' Association was formed, says the *Pittsburgh Commercial Gazette*, was the problem of effecting a satisfactory settlement for the repair of the cars of one company in the shops of another. For many years the balancing claims and counter claims for repairs to cars, and the conduction of the resulting litigation, formed the principal part of the work of the legal staffs of the railroads.

In the old days the managers of rail-

was like love and war; everything was fair and no hold was barred, but woe betide him who failed to carry his point. No quarter was shown him and none was expected. An expensive defeat usually cost him his official head. Just settlements could not be obtained in the courts because of the lack of uniformity in railroad law, and the fact that contending railroads were not satisfied to receive justice, but made it a rule to hold out for far more than they were entitled to. The judges and juries were confused with voluminous stacks of agreements and records of customs and precedents, and the side with the

bring about standards and interchange-ability in car equipment and uniformity in car legislation. To this body the task of forming a code of rules to govern the settlement of repair expenses was entrusted. A system was evolved, but it required several years to bring it to its present degree of perfection and effectiveness.

When the time for its adoption came, the old spirit of revolt manifested itself and it was a question for a long time whether or not a universal agreement could be reached. But the courts, tired of the senseless and useless litigation, which consumed their time, used their influence for peace and public sentiment and the fact that the majority of the railroads favored it, forced its acceptance.

Its fundamental principles have become laws in every State of the Union and while its adoption has not entirely excluded litigation, it has reduced the legal expenses of railroads to a very great degree. Set rules govern almost every contingency, but when the last means of peaceful settlement has been exhausted the question is referred to a board of arbitration composed of members of the Master Car Builders' Association. The decisions of this board are usually accepted and only in rare instances do the contending parties resort to the courts.

LITTLE IS NOW TAKEN FOR GRANTED.

By the provision of the Master Car Builders' agreement, very little is taken on trust. A rigid inspection of cars passing from one railroad to another is made at the transfer point. A car which has been damaged or which contains defects is not accepted until the delivering railroad gives a certificate acknowledging such defects and damages, and this certificate is a warrant empowering the receiving railroad to repair the defects or damages at the expense of the delivering railroad.

To prevent the receiving railroad from charging an extortionate price for the repairs, the agreement contains an expense table which defines the kind and limits the amount of material to be used in making repairs, and fixes the price and the amount of labor on the work. The parts put in must be of the same dimensions and quality as those replaced. This is not a difficult provision to comply with, as there are universal standards for car building and all the standard sizes and qualities of material are kept in stock at repair shops. This rule applies even to paint. It must be of a standard color, tint and quality. A given quantity must cover a given amount of surface and a definite length of time, at a definite hourly wage rate, is allowed for putting it on.

To insure payment for repairs coming under this head, the railroad in

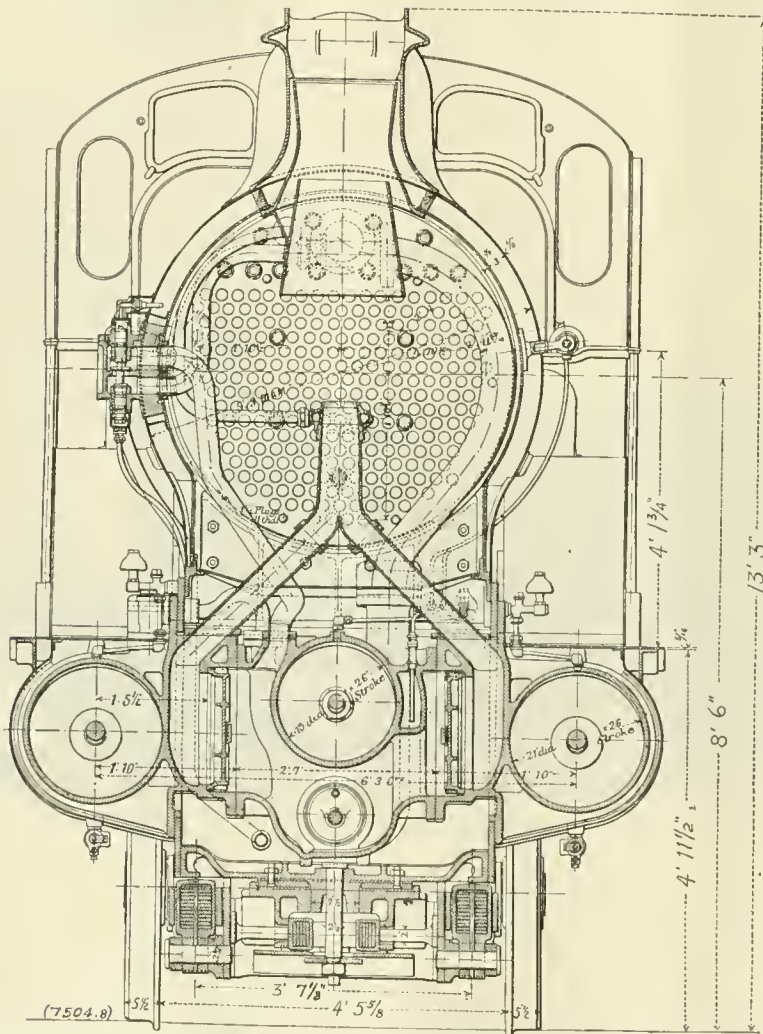

SECTION SHOWING CYLINDERS, STEAM PIPES AND AUTOMATIC REGULATING VALVE ON SIDE OF SMOKE BOX—MIDLAND RAILWAY.

roads which interchanged cars met once or twice a year, formulated repair agreements which were signed unanimously, and after these meetings the dinner, which always concluded these meetings, hastened home where each apparently sought to be first to either repudiate the agreement or to use it as a means of getting the upper hand of a connecting line.

FORMERLY EVERY TRICK WAS FAIR.

As one of the men who was a railroad manager 25 years ago expresses it, "It

lawyers most fertile in expedient and cunning usually got the decision, despite the law applying to the case.

In the course of time the unwisdom of this way of doing business became manifest and steps were taken to establish a uniform system on a "peace" basis which would do away with the ruinous expense and oftentimes flagrant injustice arising from appeals to the courts. The association of the Master Car Builders had been formed partly for the exchange of ideas, but mainly to

whose shops the work is done must not only comply with the foregoing provisions, but must follow a prescribed form of recording the repairs on a card which is attached to the car, and which must be acknowledged in writing when the car is turned over to the road responsible for the repairs. Any failure in this respect absolves the company against which the bill is rendered. Cars having defects or damage which make their further movement unsafe are not accepted at transfer points. In case the car may be moved safely and the receiving road does not wish to make the needed repairs, or must deliver the car to a third line, records of the defects and damage must be kept by each road receiving the car and formal notice given to the responsible road. A failure to give such notice places the responsibility for repairs on the road last handling the car and failing to give such notice.

REPAIRS DIVIDED INTO TWO CLASSES.

Repairs made necessary by breakdowns on the road over which a car from another line is being hauled, are divided into two classes. If the car has been subject to "fair usage," which means that it has not been derailed or been in collision, or suffered especial strain or severe shock, the owning company is responsible for the repairs when duly notified in the prescribed manner.

But if the breakdown causes a wreck in which other cars are destroyed or damaged, the owner of the car which caused the wreck is responsible only for the repairs to his own car. The company on whose line the accident occurs must shoulder all the rest of the expense resulting from it.

This seems unfair, but it is railroad law based on the ground that inspectors at transfer points should be able to discover dangerous defects and weaknesses. As a matter of fact, an inspection complete enough to do this would require the lifting of the car from its trucks and a minute and tedious examination of every part of it. This, of course, is not practicable, hence the car is passed after a comparatively superficial examination and the receiving road excepts the chance of hidden defects.

If the car is damaged by any accident for which it was not responsible the company on whose line such "unfair usage" occurred must pay the expense of the repairs. The question of the completeness of these repairs is, in the case of freight cars, settled by a conference of inspectors at transfer points. When passenger cars, especially parlor, dining and sleeping cars, are damaged, a representative of the owning company is usually sent to the shop where the repairs are to be made. He is prac-

tically the sole arbiter of the extent and character of the repairs. If the requirements of the owning company are deemed unreasonable the question may be submitted to a board of arbitration, but one side or other usually yields a point rather than incur an expense greater than the amount involved.

ONE OPENING FOR DISHONESTY.

It is in the question of fair and unfair usage that the only opening for dishonesty exists. If, for instance, a car owned by a road running east from Pittsburgh is returned from a road running west from Chicago with a broken flange or with a new wheel and a bill for the same, it is almost impossible to tell to a certainty whether the break occurred during fair usage or whether it was the result of a derailment or other accident. A careful examination of the surrounding parts would be made, and, if no other damage and no evidence of accident could be found, the statement of the company on whose line the break occurred would be accepted and the bill paid. If, however, a truck beam, or the bolster were found to be broken, or the parts adjacent to the wheel in question were damaged or badly scarred, they would be regarded as prima facie evidence that the car had been in an accident and that the repairing company's assertion of fair usage was either false or doubtful. If the claim was not withdrawn after the foregoing evidence was presented to the claimant, the entire matter would be submitted to the board of arbitration.

The advent of the steel car has enhanced the difficulty of straightening out these knotty points to some extent, as the steel does not yield or even show traces of blows or accidents which would shatter wood or affect combined wood and steel construction. The steel car has also made necessary the installation of new departments and new apparatus in repair shops. They require movable heating devices which may be applied to any part of them, so that bent pieces and sections may be straightened and made plumb and smooth by heating and hammering them without removing them from the car.

In the almost endless records of litigation over the repair of the cars of one railroad in the shops of another, a case which was decided only a few days ago is one of the most interesting both to railroad men and the public at large. A box car of the Erie railroad was being hauled over the Galveston, Harrisburg & San Antonio Railroad, in Texas. It contained merchandise in transit from Cleveland, O., to a southwestern point. Near Waco, Tex., a tornado blew the entire train from the

track, killing several of the trainmen and wrecking the cars, the debris of which was completely destroyed by fire from the locomotive, with the exception of the metal parts.

The Erie company presented a claim for the value of the car, but it was ignored by the Texas road until the matter was brought before the board of arbitration. The Texas company based its defense on the fact that the Erie car was receiving fair usage at the time the train was wrecked and that the tornado was an act of Providence which could not have been foreseen or provided against. Many witnesses were called to prove that the train had been wrecked by the tornado, but this point was not disputed. The defendant company argued from the foregoing that it had complied with the law and custom in every respect; that it had not been negligent in any way and that, therefore, under the terms of the Master Car Builders' agreement, it could not be responsible to the Erie company for anything but the scrap iron recovered from the car, which it agreed to pay for. The Erie company merely stated that it had delivered to the Texas company, in good order, a car which had never been returned to it. The latter company's receipt for the car proved the statement.

THE ERIE STUCK FOR ITS POINT.

The Erie company argued that it was unreasonable to extend the Master Car Builders' agreement to the case and declined either to accept the scrap iron in lieu of its car, or to pay all the rest of the expense of building a new car into which the scrap iron should be incorporated.

The arbitration committee, after a year's consideration, decided in favor of the Erie company. The Texas road refused to abide by the decision and the Erie company sued to recover the value of the car. The outcome of the action was awaited with general interest and the court's recent decision in favor of the Erie company met with general approbation.

Spontaneous Combustion.

There is a remarkable tendency observable in tissues and cotton, when moistened with oil, to become heated when oxidation sets in, and sad results often follow when this is neglected. A wad of cotton used for rubbing a painting has been known to take fire when thrown through the air. The waste from vulcanized rubber, when thrown in a damp condition into a pile, takes fire spontaneously. Masses of coal stored in a yard have been known to take fire without a spark being applied, and one cannot be too careful in storing any substance in which oxidation is liable to take place.

Signals and Signaling.

BY GEORGE S. HODGINS.

(Continued from page 180.)

AUTOMATIC BLOCK SIGNALING AT AN INTERLOCKING POINT.

On any block signaled railroad there are sometimes conditions which the locality or the exigencies of traffic place before the signal engineer and for which a solution must be found. One of these conditions is the presence of a swing bridge which interrupts the continuity of the permanent way, and the other is the use of one or more additional tracks from a point where the pressure of traffic has compelled the use of greater facilities. A convenient example where both of these conditions are to be found is on the Delaware, Lackawanna & Western Railroad at Newark, N. J.

The Passaic river at that point is spanned by a double deck swing bridge about 100 ft. long and from Newark station eastward to Hoboken there are two tracks and from Newark westward for about nine miles there are three tracks, an eastbound track, a westbound track, and a center track. This latter track is used from midnight to noon for the eastbound movement of traffic, and is used from noon to midnight for the westbound movement. The diagram here given shows the position of track, signals, towers, swing bridge, etc.

The object of this arrangement is that for the eight miles between Hoboken and Newark two tracks are adequate, because practically no stops have to be made and good speed may be maintained by all

the longest in duration the track accommodation is actually doubled. A similar movement in the opposite direction in the morning hours is handled with facility in the same way, the track accommodation being reduced on that portion of the line where higher speed is possible and where stops are not required.

The object of block signaling is to

A glance at the diagram will show two signal towers, a bridge tower on the swing span and an interlocking tower near the beginning of the third track, close to Newark station. Unlike the manual controlled system, the signal men in these towers are quite independent of one another, and they each operate only those signals with which permissive blocking would be impossible.

Following the westbound track from the left we find the signal marked A. It has one "home" signal at the top of the post operated by what is called an electric slot instrument, on the post, and below are two "distant" signal arms. There is a derailing switch fifty feet from this signal which renders entrance on the bridge against the signal at "stop" an impossibility. The "distant" at A act in unison with the two "home" signal arms at B, and in addition to advising "caution," indicate the route which has been made by the interlocking signal tower at Newark.

The signal man in the bridge tower operates the "home" at A in conjunction with the derailing switch. It is absolutely impossible for him to clear the "home" at A until the bridge is locked in position



INTERLOCKING ELECTRIC SLOT "HOME" SIGNAL AT NEWARK, N. J.—D. L. & W. MARKED B IN DIAGRAM.

maintain a space interval between trains moving in the same direction over the same track. The object of interlocking signaling is to indicate a route, and to guarantee its safety or to command a

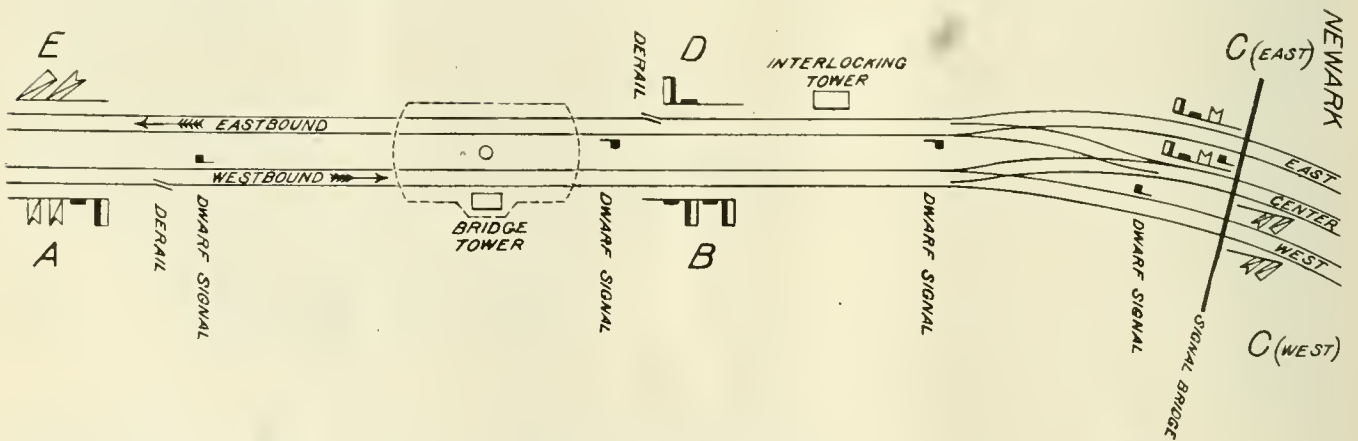

POSITION OF TRACKS, SIGNALS, SWING BRIDGE AND TOWERS ON THE D. L. & W. AT NEWARK, N. J.

trains, but west of Newark the local traffic imposes many pick up stops upon the morning toward trains and many set down stops on the evening suburban trains. The home movement of the Lackawanna's many short journey trains in the evening is over the westbound line to Newark and from that point on, each alternate train takes, say the first, the center track, the next the regular westbound line, the next the center, and, so on. On the portion of the line where the stops are the most frequent or

halt. For the latter of these two reasons all interlocking signals are operated on the "normal stop" principal, which means that in order to indicate "proceed" they must be pulled down to the "all clear" position by the man in charge. We have on the short stretch of track near Newark an interesting combination of block and interlocking signaling which has given every satisfaction and which is maintained and operated in accordance with the Lackawanna's high standard of signal equipment and engineering.

for railroad traffic, and then only after the derailing switch has been closed. The lowering of the "home" at A indicates "proceed" and guarantees a safe line. The post is without any designating number which, on the Lackawanna, means that permissive blocking is prohibited.

The next signal on the westbound track which both men on a moving engine look for is the signal marked B. Upon this post are two interlocking "home" block signals. This post is also without a number and when both arms

are horizontal, demands an indefinite halt.

Signal B is operated from the interlocking tower and the lowering of either arm is the last act of a series of lever movements which makes the route and locks the switch rails for an oncoming train. Lowering the topmost arm makes



INTERIOR OF INTERLOCKING TOWER ON PASSAIC BRIDGE—D, L. & W.

the route over the continuous westbound track, and dropping the lower arm indicates that the diverging route has been selected. Both these signal arms though worked from the tower are yet controlled by a pair of electric slots, on the post.

The slot machine is simply an ingenious piece of mechanism which while it permits either signal to be cleared by the signalman, returns the signal arm to the "stop" position without his assistance, on the passing of a train. The electric slot signal mechanism is used to make a part



ELECTRIC SLOT INTERLOCKING SIGNAL AT ENTRANCE OF NEWARK BRIDGE OVER THE PASSAIC ON THE D. L. & W. MARKED D IN DIAGRAM.

of the movement automatic. The signal can be cleared by hand, but the heavily counterweighted signal arm flies back to the "stop" position on the release of a detent in the machine, caused by a short circuit in the track current. This short circuit is brought about by the presence of a train in the block. The signal man

can, by the manual movement of the signal, let a train in on the track beyond the electric slot signal when the track is clear, but the automatic action of the slot mechanism prevents the possibility of his permitting a second train to follow until the first train has passed into the block next ahead. When a passing train has put either of the signal arms at B to "stop" behind it, the signalman in the interlocking tower cannot lower one or the other until the train has passed beyond the signal bridge marked C. In order to facilitate rapid train movement the signals at C are placed about 430 feet west of the signal tower, and the whole block is probably about 450 feet long. Two trains, one of which takes the westbound mainline, and the other the center track may enter each its own route with perfect safety at a short time interval if de-

interlocking tower and governed each by an electric slot machine. These signals stand normally at "stop," and one of them only can be pulled down by the signal man in the interlocking tower if a train has passed beyond signal D.

The "distant" at C acting in unison with the "home" at E would clear automatically as the "home" at E cleared if it got the chance, but as it goes to the horizontal position along with the "home" above it, every time, and as it also requires the signal at D to be clear before it can clear, and as the topmost arm at C and the signal at D are operated each from a tower and are worked on the "normal stop" principle, the practical effect is that the "distant" at C continually shows "caution" until "cleared" by the lowering of the top arm at C and the bridge signal at D and the automatic at E.



SIGNAL BRIDGE AT NEWARK, N. J., ON THE D. L. & W. TWO RIGHT HAND TOP SIGNALS HAVE EACH AN ELECTRIC SLOT MECHANISM. DWARF SIGNAL ON LOWER CHORD OF BRIDGE. BRIDGE MARKED C IN DIAGRAM.

sired, owing to this block being a short one, but one train cannot follow another along the same line except as permitted by the ordinary automatic block signals at C. The signal arms at B are mechanically interlocked so that both cannot be cleared at the same time, and as the "distant" at A act in unison with the "home" signals at B, a correct indication of the route as it exists at B is thus given at A. If the swing bridge opens, all the signals at A stand in the horizontal position, and, as the track circuit is thus broken, the signals at B cannot reproduce any route indication on the "distant" at A. In this case B is the "home" for the block of which the two lower arms at A are the "distant," while C is the "advance home" for the block.

On the eastbound track the signals at C are automatic block signals having the topmost arms operated from the

The dwarf signals shown are for backing up movements. They are always in the "stop" position unless when such movement is actually in progress. The short arm of the signal is made of stiff sheet rubber, painted. The arm is therefore not liable to be broken.

In long lines of pipe which move on rollers or pipe carriers and form the connection between tower and signal, there is placed, usually about every 700 feet a piece of mechanism called a compensator. This consists of two bell cranks one of whose arms enclose an acute angle, and resembles the letter V. The other has arms which make an obtuse angle with each other like the hands of a watch showing 4 o'clock. These bell cranks are placed with pivot points parallel to the line of motion, and the outside arm of each is on the same side of the pivots. The other arms stretch

outward parallel to each other and are connected by a link. By reference to the compensator diagram it will be seen that expansion of the pipe line attached at X will cause any movement to be to the left, and any expansion of the pipe line at Y will be to the right. The mutual movement of X and Y toward each

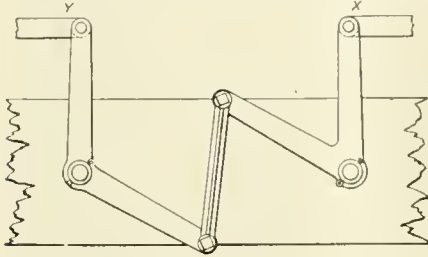

A SIGNAL PIPE-LINE COMPENSATOR.

other will force the other arm of each bell crank downward and this motion being at right angles to the pipe line will take up the movement due to expansion or contraction without altering the relative position of the centers upon which each rotates. The positive movement of X due to a shifting of the signal lever will always produce a corresponding movement at Y. It is clear that a pull at X will, of course, be transformed into a push at Y and vice versa, but the distance moved by Y will be exactly equal to that moved by X.

The suburban traffic handled over the tracks of the Lackawanna Railroad is very heavy, especially during the summer months, and the record of signal

of the whole system is excellent. The officials of this road have recognized the importance of another factor in this problem, which is not to be had by the mere expenditure of money, but without which the most costly system is of little value as a guarantee of safety. The signals are there, they operate faithfully, and the men on the road are taught to obey them implicitly. It has been poetically said that "Education is the handmaid of Religion," but it is not a whit more than the sober truth to say that in the railway world, Discipline is the handmaid of Safety, and though transportation companies may cut down their expenditure to the lowest legitimate point, they can never afford to disregard the invaluable service which the handmaid to safety alone can render.

(To be Continued.)

How Steel Rules are Made.

There are few branches of the engineering trades that require the exactness and precision requisite in the manufacture of steel rules, standards, and measuring instruments.

Accuracy and reliability are the two absolute essentials. In the general practice the steel blades, after being prepared by being ground, glazed and tempered, are coated by an acid resisting varnish, specially made to suit the requirements of the trade, for upon this depends, in a great measure, the clearness of the divisions when etched. The varnish being dry, the blades are placed upon the table of a pentagraph, which might well be termed a copying machine, as its work is to transfer to the steel blades, in a diminished size, any marks, letters or figures that may be traced from the copy.

The latter is a plate of thin zinc, or any suitable metal, usually four times larger than the rules to be made, the divisions, figures and letters all being made four times larger than they are required to be when engraved upon the steel blades; the object of this increased size being to diminish any imperfections that may exist upon the copy. There is a tracer connected by a system of steel bands and pulleys to the table so constructed as to move in two opposite directions at right angles at each other. Above the table are fixed two rows of holders, each having a diamond point; these holders are raised and lowered at the will of the operator by a treadle, so that both divisions,

figures, and letters are traced from the copy and transferred, in a diminished proportion, to the steel blades. The diamond points being required only to cut through the varnish, the blades are taken from the machine and etched, the acid burning away the steel wherever the diamond point has been traced.

Wheel Resistance.

If one horse can draw a certain load over a level road on iron rails, it will take one and two-thirds horses to draw the same load on asphalt, three and one-third horses to draw it on the best Belgian block, five on the ordinary Belgian pavement, seven on good cobblestones, thirteen on bad cobblestones, twenty on an ordinary earth road, and forty on a sandy road.

The Minnesota Central is a new line from Mankato, Minn., it runs in a northerly direction through St. Cloud to Duluth, 200 miles. The contract has been

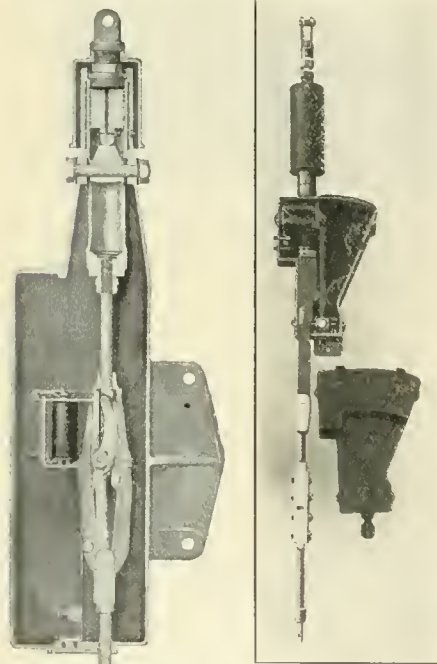

FIG. 1. Union Switch and Signal Co.
FIG. 2. Hall Signal Co.

failures, which is accurately kept, shows that the number getting out of order is exceedingly small. The signal equipment is good and the maintenance



DWARF SIGNAL, USED IN BACKING UP MOVEMENTS.

let to C. E. Coon & Co., Houston, Tex. Mr. D. H. Beecher, Grand Forks, N. Dak., is president, and H. B. Cady, Minneapolis, is treasurer. Mr. Beecher is also president of the Lawson Boat and Car Company of New York.

To Polish Nickel Plate.

To brighten and polish nickel plating and prevent rust apply rouge with a little fresh lard or lard oil on a wash leather or piece of buckskin. Rub the bright parts, using as little of the rouge and oil as possible; wipe off with a clean rag slightly oiled. Repeat the wiping every day, and the polishing as often as necessary.

Baldwin 2-8-0 for the Hermit Kingdom.

Our illustration shows a good example of a Baldwin 2-8-0 simple engine, built for the Japanese Government. It will run on the Seoul Fusan Railway, a standard gauge road which connects the principal cities of Korea.

The cylinders are 20x26 ins., and the driving wheels are 54 ins. in diameter. The whole engine weighs in working order, 137,394 lbs., and with 180 lbs. steam pressure, the calculated tractive effort is about 29,500 lbs., and the ratio of tractive effort to adhesive weight is as 1 is to 4.17, the weight on the drivers being 123,194 lbs.

The valve gear is indirect, and the main valve used is an ordinary balanced D-slide. The pistons drive on the third pair of driving wheels and the eccentrics are on the axle of this pair. The transmission rod is, therefore, carried back from the link to the lower end of

gallons. The total weight of engine and tender is about 217,000 lbs. A few of the principal dimensions are appended for reference:

- Boiler—Dia., 60 ins.; thickness of sheets, $\frac{5}{16}$ in.; working pressure, 180 lbs.; staying, radial.
- Fire box—Length, 108 $\frac{3}{8}$ ins.; width, 41 ins.; depth, front, 60 $\frac{3}{4}$ ins.; back, 58 $\frac{1}{2}$ ins.; thickness of sheets, sides, $\frac{1}{8}$ in.; back, $\frac{1}{8}$ in.; crown, $\frac{1}{2}$ in.; tube, $\frac{1}{2}$ in.; water space, front, 4 ins.; sides, 4 ins.; back, 3 $\frac{1}{2}$ ins.
- Driving wheels—Journals, main, 8x9 ins.; others, 8x9 ins.
- Engine truck wheels (front), dia. 30 ins.; journals; 5x9 ins.
- Wheel base—Driving 15 ft. 0 ins.; total engine, 23 ft. 0 ins.; total engine and tender, 50 ft. 7 ins.
- Weight—On driving wheels, 123,194 lbs.; on truck, front, 14,200 lbs.; total engine, 137,394 lbs.; total, engine and tender about 217,000 lbs.

Impressions On and By the Way.

BY A WOMAN DRUMMER IN A MECHANICAL LINE.

When a little while ago you wished me a pleasant and successful trip, as I was

ished. Who wants to eat a dollar breakfast? Then comes luncheon and dinner; I am quite willing to pay a dollar for my dinner, but I am not willing to pay a dollar for each of these meals and be glared at by a waiter because, in his eyes, my tip is too small, and be given a finger bowl the water in which has been used by someone else. I am very certain the Pennsylvania Railroad would not tolerate this.

Many lines for traveling northwest are offered one in Chicago; as I could go by one only, I choose the C., B. & Q., one of their finest trains—splendidly equipped cars, well lighted, but overheated. On my return I bought my ticket via the Chicago, Milwaukee and St. Paul—I am not handing out bouquets, but if I were, I might select a few flowers to give the C., B. & Q., but the biggest, choicest hunch would be offered the "St. Paul." It will be pleasant to remember that trip all my life; the roadbed is smooth. the

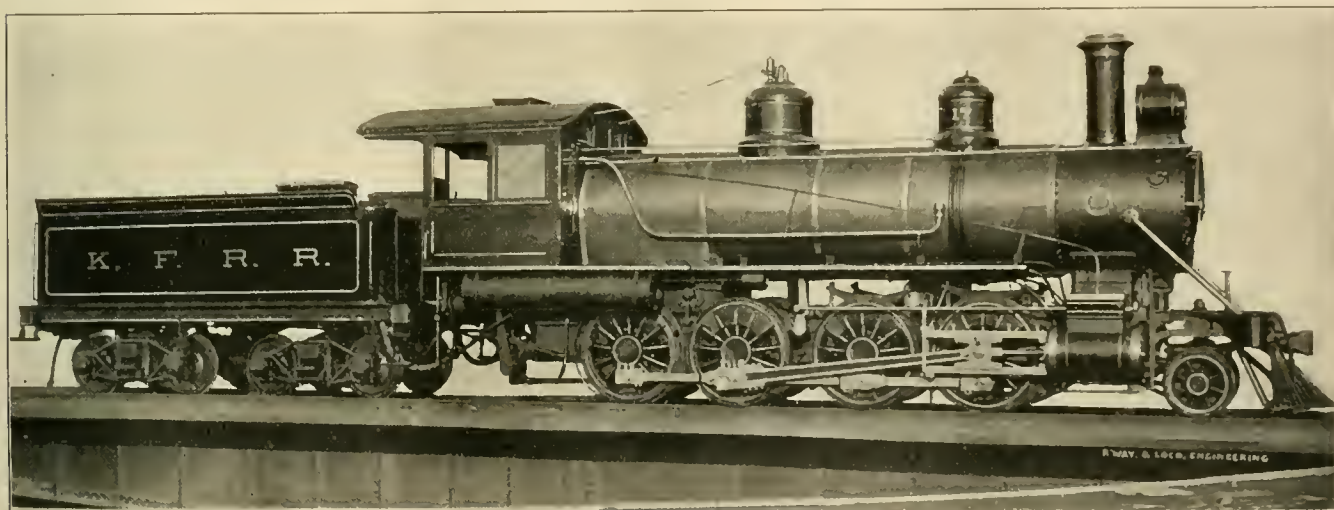

BALDWIN 2-8-0 FOR THE JAPANESE GOVERNMENT.

the rocker, which latter comes out between the main and the second driver. The main and the second drivers are not flanged. The spring system is such that the pony truck and the leading drivers are equalized, and the three rear drivers are equalized together. The first two drivers have overhung springs and the last two have springs placed between top and bottom frame bars and also between wheels and back of rear drivers.

The boiler is a straight top one with semiwide fire box. The crown sheet and roof sheet are level and there is a steam space of about 20 ins. between them. The boiler is 60 ins. in diameter and the tubes, which are 240 in number, are 13 ft. 10 ins. long. The heating surface is 1,875 sq. ft. in all, of which the tubes contribute 1,727.8 sq. ft. and the fire box 147.2 sq. ft.

The tender is of the usual type, the tank having a capacity of 4,000 U.S.

starting off for "farther than I have ever been before," you asked me to let you know how I liked it; and as I had a constant reminder by seeing RAILWAY AND LOCOMOTIVE ENGINEERING frequently among railway men I met, I decided to give voice in that valued paper to my impressions on this journey of a few thousand miles. Being very anxious to see the Horseshoe Curve, I traveled over the Pennsylvania to Chicago, on the finest train they run. The man who fashioned that horseshoe surely whistled the "Anvil Chorus" when he had finished. It is a wonderful piece of engineering. It was very nice to travel on this limited train, but it had its drawbacks; unless limited as to time, I would not care to do it again. My "grumbling" is, however, confined to the meal business and overheated cars. The dining car service is, I believe, operated by the Pullman Co. I want to say most emphatically that the "dollar a meal" system ought to be abol-

cars are the very finest, the attendants—conductors, porters, waiters and the men in charge of the dining cars—most kindly and attentive; the food is excellent, abundant and carefully served; the "tips" it suited me to give were accepted in a nice manner, the men seemed pleased.

Here I want to say that where railway companies operate their own dining, parlor and sleeping cars, the service is the best, one's comfort the greatest, the employees act as if they wanted to please their "road" by doing well by its patrons, and I think the traveling public recognizes this.

On the Rock Island & Pacific Railroad I was agreeably surprised by the way the conductors and porters came to tell me what the different places were we passed and their kindly care in guarding one from draughts, helping one to alight at stations where the train stopped for a few minutes, "to get a breath of air," made the journey most pleasant.

This road seems to take a personal interest in its patrons, and in every sense it is high class, the service is the very best. How I should like to journey to California on "The Golden State Limited!" But am going to stop over now, at Davenport, Iowa, one of the Tri-Cities—busy, industrious triplets, who seem to try to beat each other at which one is going to grow the fastest! The government (draw) bridge across the Mississippi here is a very fine structure. The Tri-City Electric Railway runs its cars across this bridge to Rock Island and Moline. At the latter place I made a short, but most pleasant stay, putting up at the Manufacturers' Hotel. Moline may well be proud of this comfortable inn; hotel keepers of large cities could learn much to their advantage by spending a day or two here. The house is large, the interior decorations refined and beautiful, the rooms most comfortably furnished and scrupulously clean, the service excellent. The proprietor seems to be there to make you comfortable and welcome; neat, cheerful, kindly girls attend to your wants and wishes in the dining room. Seeing a small boy putting the finishing touches to the already bright fixtures in the elevator, I said: "You keep this place beautifully clean," the youngster looked up at me and answered: "Thank you, mam." How different was the big hotel I stayed in at St. Paul! I am not going to tell you which one it was, if any of the L. E. readers have been there they know which one I mean, if they haven't, they will know which one when they go there. I was very glad to leave; was afraid they would pull out my teeth to get the gold fillings—those same teeth had done some hard service trying to meet through the steak furnished at the tables of this hotel.

From St. Paul to Minneapolis I went by trolley. The electric road is owned and operated by The Twin City Rapid Transit Co. They run large, well built, well heated cars kept beautifully clean. I was amused watching a conductor who in turn was watching a passenger who seemed to be going to break the ordinance: "Do not spit on the floor." The conductor said, "Are ye goin' ter spit? This here car is no cussidor." The would-be culprit reminded me of a patient who, on having the small clinical thermometer placed between his lips for the first time, removed it and said: "If ye please, doctor, do ye want me to swaller the juice." The western electric railways are superior to those in the East. The Twin City Railway has very fine shops where they build their own handsome cars; I was shown all through and it gave me great pleasure.

In Chicago I noticed some very large nice cars operated by the Chicago Union Traction Co. They are heated by electricity, the heaters placed right under the

seats, very close to the cushion. I don't want to be sitting down in these seats when the heat is turned on—should imagine it would make people "sit up!" But then, that's in Chicago; people there do not mind standing up, do not even need the support of straps.

The finest railroad shops I visited were those of the Chicago & Northwestern Railway. They are light, airy and spick-span. The rule: a place for everything, and everything in its place, seems to be followed here. But I think all the railway companies have fine shops; they employ skilful, practical men as heads of their mechanical departments; they in turn employ good workmen, and furnish them with the best machinery and tools, as we supply people well know.

To go much more into telling you about the different roads I traveled over would take up too much of your space and my valuable time; so, am going home. I went from Canton, Ohio, to Cleveland by the Wheeling & Lake Erie Railroad. All I have to say about this is that I found the Wheeling pretty rough.

Now for my friend, the Nickel Plate. I do not know any of its officials, but as there are no strings that tie my hat to my head, I take it off to them! This is not an awful "swell" road, but it is comfy. Rich and poor may travel East or West and have every comfort. Traveling from Chicago to New York one has a choice between going via the West Shore or by the Lackawanna in through cars; this time I came by the latter. Much praise is due the Nickel Plate for the kindly, thoughtful, courteous care given the man or woman who with a thin purse has to travel East or West. In the coaches they have an attendant who looks after the comfort of all travelers there, and though you carry an old carpet bag or a nice new suit case, he is good and kind to all. Meals are served in the dining cars at reasonable charges; I want no better supper than I had on dining car No. 101. Too much or too little heat was the only drawback—the steam enemy again. Cars cannot be kept comfortable with steam heat; when they become overheated the ventilators are opened wide, result: cross currents and draughts, cross, sneezy passengers, colds in the head, and worse to follow, often. I liked the Lackawanna well enough. Everything was good; the ride from Binghamton here lovely; but I was very cold in the night and in the morning until we had left Binghamton—then they made you wish for a cake of ice.

My sincerest admiration is extended to all the railway officials I met; they are gentlemen, in every sense of the word, courteous and most kindly. I think that if we supply people would consider for a moment that purchasing

agents, superintendents of motive power, master mechanics, and all the other officials have something else to do, someone to see and listen to beside ourselves, we would be more thoughtful and take as little of their time as possible; state our business, solicit their interest and—leave, we would always be welcome on our next visit.

To Pullman porters and to a goodly number of brakemen I want to say, don't take the best unoccupied seat in parlor or sleeping cars and stretch yourselves out in solid comfort, making an effort to show the fancy pattern of your socks. It looks badly, and many passengers hesitate to put their feet on the opposite seats or chairs. Don't try to entertain the passengers with your skill in whistling; go and visit the roads that operate their own cars, it might do you good.

There, Mr. Editor, I will step down from my pulpit or some of the L. E. readers will go to sleep and they might not want to hear from me again.

A. F. W.

Power Brakes Needed for Street Cars.

The railway street car service of New York City is remarkable for the distance they haul passengers for a nickel and for the out of the way points they reach. The companies have fine, airy cars, well heated in winter, but in one respect they are behind the first class street cars of many other cities. They are still controlled by hand brakes, an antiquated practice that is no credit to the company. The officials responsible for this backward condition of affairs shrug their shoulders when criticism is made, and ask: "Do you know what it would cost to equip all our cars with air brakes?" We know it would cost a pretty round sum but steam railroads urged the same objection at first to equipping their cars with air brakes, yet they had to fall into line. Running electrically driven street cars with nothing more powerful than the ancient hand brakes for stopping is dangerous to the public in a crowded city. The street car company will doubtless refrain as long as possible from equipping their cars with power brakes unless public sentiment is aroused to stimulate their lack of enterprise.

When railways were first introduced into the British Isles, the snobs used to persist in having their own carriages placed on flat cars so that they might enjoy the privacy so dear to the privileged classes. It was only after several carriages with their aristocratic owners had been blown off the trains and two or three set on fire that the exclusive people consented to ride among the common herd.

Of Personal Interest.

Mr. E. C. Macy is appointed principal assistant engineer of the Chicago Great Western Railway, with office at St. Paul, Minn.

Mr. W. Norman Dietrich has been appointed Electrical Engineer on the Canadian Pacific Railway with office at Montreal.

Mr. F. J. Cole has been appointed mechanical engineer of the American Locomotive Company, vice Mr. J. E. Sague, promoted.

Mr. H. C. Chandler has been appointed general storekeeper of the Chicago Great Western Railway, vice Mr. W. B. Causey, resigned.

Mr. G. A. Schmoll, superintendent of motive power of the Baltimore & Ohio, has moved his office from Newark, O., to Wheeling, W. Va.

Mr. R. J. Turnbull has been appointed master mechanic of the Paducah, Ky., shops of the Illinois Central Railroad, vice Mr. T. F. Barton, transferred.

Mr. W. Pitts, locomotive foreman at Rat Portage, Ont., on the Canadian Pacific Railway, has been transferred as acting foreman at Moose Jaw, Assa.

Mr. F. T. Patterson, locomotive foreman at Kamloops, has been transferred to Rat Portage on the Canadian Pacific Railway, as acting foreman, vice Mr. W. Pitts, transferred.

Mr. George H. Brown has been appointed master mechanic on the St. Louis & San Francisco Railroad, with office at Fort Smith, Ark., vice Mr. Thos. Paxton, resigned.

Mr. James O. Baker has been appointed purchasing agent of the Delaware, Susquehanna & Schuylkill Railroad, with office at Drifton, Pa., vice Mr. Arthur McClellan, deceased.

Mr. C. S. Lovell has been put in charge of the newly opened office of the Tabor Manufacturing Company in Boston, Mass. His address is Room 84, Mason Building, 70 Kilby street.

Mr. R. Anthony, general foreman at Fort William, Ont., has been transferred to Revelstoke, B. C., on the Canadian Pacific Railway as general foreman, vice Mr. J. Scott, transferred.

Mr. J. Scott, general foreman at Revelstoke, B. C., on the Canadian Pacific Railway, has been transferred as locomotive foreman to Kamloops, B. C., vice Mr. F. T. Patterson, transferred.

Mr. Ernest W. Saunders, recently with the American Machinery Company, is now in the New York office of The J.

R. Vandyck Company, as machine tool salesman. His office is at 8 Dey street.

Mr. A. Millison, locomotive foreman at Moose Jaw, Assa., has been promoted to be general foreman at Fort William, Ont., on the Canadian Pacific Railway, vice Mr. R. Anthony, transferred.

Mr. T. F. Barton, master mechanic at the Paducah shops of the Illinois Central Railroad, has been transferred to the Burnside shops, Chicago, of the same company, vice Mr. G. W. Smith, resigned.

Mr. William Miller, who for the past three years has been general foreman of the Colorado Midland shops at Colorado City, has been appointed master mechanic of the St. Louis Transfer Company.

Mr. A. D. Schindler, who has been superintendent of the Valley Division of the Santa Fe, recently resigned in order to take charge of the lines of the Pacific Electric Company in Los Angeles, Cal.

Mr. J. W. Walker, formerly superintendent of terminals at San Francisco, on the Atchison, Topeka & Santa Fe, has been appointed superintendent of the Valley division of that road, vice Mr. A. D. Schindler, resigned.

Mr. Jas. O'Neill, formerly division superintendent of the Great Northern Railway at Harve, Mont., has been transferred as superintendent to the Kalispell division of the same road, vice Mr. A. E. Long, resigned.

Mr. George W. Wildin, assistant mechanical superintendent of the Erie Railroad, has been appointed mechanical superintendent of that company and of their operated and controlled lines, vice Mr. W. S. Morris, resigned.

Mr. E. B. Gilbert, formerly master mechanic on the Bessemer & Lake Erie, has been appointed superintendent of motive power in charge of maintenance and equipment, and the position of master mechanic has been abolished.

Mr. J. R. Luckey, who was at one time connected with the Day-Kincaid Stoker Company, is now looking after an automatic stoker of his own invention. It is manufactured by the Luckey Stoker Company, of Cincinnati, Ohio.

Mr. W. G. Anderson has been appointed general foreman of the Southern Railway shops at Louisville, Ky., vice Mr. P. Drescher, resigned to go in business. Mr. Anderson was formerly with the Southern at Washington, D. C.

Mr. C. O. Jenks, formerly assistant division superintendent at Superior, Wis., has been appointed superintendent of the Montana division of the Great Northern Railway, with offices at Harve, Mont., vice Mr. Jas. O'Neill, transferred.

Mr. G. R. Joughins, formerly mechanical superintendent of the Atchison, Topeka & Santa Fe Coast Lines at Los Angeles, Cal., has been appointed mechanical superintendent of the Intercolonial Railway of Canada. Mr. Joughins headquarters will be at Moncton, N. B.

Mr. D. T. Kyle, formerly chief clerk in the office of the master mechanic of the eastern division Canadian Pacific Railway, has been appointed chief clerk in the office of the superintendent of motive power of lines east of Fort William, with office at Montreal, vice Mr. Thos. Hopkirk, resigned.

Mr. R. T. Shea, formerly superintendent of the Montreal Locomotive and Machine Company, has resigned and has been given charge of the installation of the New York Central Railroad Company's exhibit at the St. Louis exhibition. Mr. Shea is an interesting and valued contributor to RAILWAY AND LOCOMOTIVE ENGINEERING.

Mr. J. J. Thomas, Jr., has been appointed Master Mechanic of South Rocky Mount Shops, of the Atlantic Coast Line Railroad Company, with jurisdiction over the machinery department employees on Richmond, Norfolk, Fayetteville, and Wilmington districts, including Wilmington yard, vice Mr. J. W. Oplinger, promoted.

Mr. J. H. Manning, formerly assistant superintendent of rolling stock for lines east on the Canadian Pacific Railway, has been appointed superintendent of motive power of the Delaware & Hudson, with headquarters at Albany, N. Y. He takes the place of Mr. J. R. Slack, who has become assistant to the general superintendent of the same road.

Mr. J. W. Oplinger has been appointed mechanical inspector of the Atlantic Coast Line Company. He will report to, and receive his instructions from, Mr. R. E. Smith, assistant to the general manager, and will confer with the superintendents of motive power and the master mechanics in reference to mechanical details, shop practice and the observance of standards. His office is at Wilmington, N. C.

Mr. James E. Sague, mechanical engineer of the American Locomotive

Company, has been promoted to the position of assistant vice-president. Mr. Sague's duties will naturally be enlarged, together with the scope of his powers. A portion of the labors entailed, which now fall upon the first vice-president, Mr. A. J. Pitkin, will be shifted to the shoulders of Mr. Sague. His office will continue to be in New York City.

Mr. Ervin Dryer has resigned his position in connection with the Westinghouse Electric & Manufacturing Company, and has accepted an appointment with the Allis-Chalmers Company. Mr. Dryer's connection with the Westinghouse Company extended over a period of 16 years. He is one of the most competent salesmen in the electrical and mechanical field, and his wide acquaintance throughout the western part of the United States will be of great service to the Allis-Chalmers Company in the extensive new developments which they have undertaken. He has already entered upon his new duties with the Allis-Chalmers Company, and his headquarters will be at their offices in the New York Life Building, Chicago. He will give his attention to their engine work as well as to the sale of Bullock electrical apparatus, which the Allis-Chalmers Company now control through their acquisition of the Bullock Electrical Manufacturing Company, of Cincinnati.

Mr. R. L. Whyte, who furnished information concerning the real inventor of the link motion and whose picture appeared on page 128, March, 1904, issue of RAILWAY AND LOCOMOTIVE ENGINEERING, is a resident of Hamilton, Ontario, Canada. He entered the drawing office of Robert Stephenson & Co., of Newcastle in 1835, and is well qualified to speak concerning the early history of the link motion. He unhesitatingly gives the credit of the invention to William Williams, the youngest draughtsman in the Stephenson works at the time Mr. Whyte was chief draughtsman. Not long ago Mr. and Mrs. Whyte passed the sixtieth anniversary of their wedding day. They were married in Paris, France, at the British embassy. Lord Cowley, the brother of the Duke of Wellington, was then Great Britain's ambassador to France.

Mr. Robert Williams has been appointed general superintendent of the Toledo, St. Louis & Western Railroad, with headquarters at Toledo, Ohio. Mr. Williams was for many years connected with the Burlington, Cedar Rapids & Northern Railway, where he rose from the position of office clerk by the lines of claim agent, purchasing agent, assistant superintendent, superintendent to general superintendent

and vice-president. The great improvement effected on the B., C. R. & N. which made it a valuable property which several great trunk railroad systems struggled for years to get possession of were in a great measure due to the excellent management of Mr. Williams. His strong characteristic is grasp of details—there is nothing escapes his notice from a wornout tie to run down locomotives. His policy always was keep things up—a stitch in time saves nine. The work which Mr. Williams has done entitles him to be regarded as one of the most valuable operative railroad officials in the country.

Mr. A. E. Mitchell, formerly superintendent of motive power of the Northern Pacific, has been appointed superintendent of motive power of the Lehigh Valley Railroad with office at South Bethlehem, Pa., vice Mr. H. D. Taylor, resigned. Mr. Mitchell is a graduate of the Maine State College, having been in the mechanical engineering class of 1875. He began practical work in the Baldwin Locomotive works as an apprentice, after which he went to the Pennsylvania, and was employed in the testing and signal departments up to 1881. Mr. Mitchell varied his practical experience by spending a few years with the firm of Yale & Towne and other manufacturing concerns. In 1886 he became engineer of signals on the New York, Lake Erie & Western, after which he was given the post of mechanical engineer of the Chicago & Erie. In 1892 he became superintendent of motive power of the whole Erie Railroad system. He left the Erie about three years ago and went to the Chicago, Milwaukee & St. Paul as assistant superintendent of motive power and subsequently became superintendent of motive power of the Northern Pacific, which position he has resigned to take charge of the motive power department of the Lehigh Valley road.

Mr. R. N. Durborow, superintendent of motive power of the Pennsylvania division of the Pennsylvania Railroad, has had his jurisdiction extended to include that portion of the Philadelphia & Trenton Railroad between Frankford and Kensington, Philadelphia; the line of the Pennsylvania Railroad from Trenton avenue to Dock street, Philadelphia, and branches; that part of the Connecting Railway from the junction with the Philadelphia & Trenton Railroad at Tioga street, Kensington, to west end of draw-bridge over Frankford Creek, or a distance of 4.1 miles, and from the junction with the Philadelphia & Trenton Railroad near Erie avenue to Frankford street, Philadelphia; also north of the north side of

Sixty-second street, on Maryland Division, P., B. & W. R. R., and east of a point 855 feet west of Forty-ninth street, Philadelphia, on Central division, P., B. & W. R. R.; also including all the P., B. & W. R. R. tracks from Gray's Ferry Yard to the Delaware river via Washington avenue, and from Washington avenue to Almond street via Swanson street; the Junction Railroad from the north end of Market street tunnel to Gray's Ferry, Philadelphia, including car inspectors, engine houses, shops, shop yards, coaling stations, air compressor plants, etc., in the above districts.

Obituary.

John L. Weeks, treasurer and general manager of the American Steam Gauge & Valve Company, Boston, died this week as the result of complications arising from an operation for appendicitis two years ago, his death being entirely unexpected. Mr. Weeks was born in Akron, Ohio, 38 years ago, and had been with this company more than 15 years; first as traveling salesman, then as manager of the Chicago office, and finally was appointed general manager five years ago.

Thomas Downie, trainmaster of the Canadian Pacific Railway at Revelstoke, B. C., was accidentally killed as the result of a snow slide in the Selkirks. The deceased was a graduate of Upper Canada College, and lived for several years in Toronto, having been connected with the Northern Railway. His brother is Mr. W. Downie, of St. John, N. B., general superintendent of the Atlantic Division of the C. P. R.

Robert Sample Miller, who was connected with the mechanical engineering department of Purdue University, died recently at La Fayette, Ind. At an early age he entered the senior preparatory school at Purdue. After his university graduation he was first employed as special assistant and computer in the office of the department of mechanical engineering.

John Reilly, president of the United States Metallic Packing Company and of the Millwood Coal and Coke Company, and vice-president and treasurer of the American Locomotive Sander Company, died recently at his home in Philadelphia. Mr. Reilly was 69 years old. He was a native of Central Pennsylvania, and represented Blair county in the Forty-fourth Congress. In early life he went into railroad work, and for thirty-one years was connected with the Pennsylvania Railroad. He rose to the position of superintendent of transportation. After severing his connection with the Pennsylvania he associated himself with the United States Metallic Packing Company.

Baldwin 4-6-0 for the Erie.

In our April issue we described and illustrated some freight engines recently bought by the Erie, in carrying out their plan for improving the motive power of that important trunk line. We are now able to give a little information concerning some ten-wheel passenger engines which have lately been received by the Erie from the Baldwin Locomotive Works.

The engines here illustrated are simple, with cylinders 19x26 ins. The driving wheels are 68 ins., and the main driver, which is in the center, is without flange. The weight on the driving wheels is 132,110 lbs. With 200 lbs. boiler pressure, the tractive effort is about 23,460 lbs., and the ratio of tractive effort to adhesive weight is as 1 is to 5.6. The valve motion is indirect, and the valves are of the ordinary balanced D-slide type.

Fire Box—Length, 11 ins.; width, 66 ins.; depth front, 62 ins.; depth back, 50 ins.
 Water Space—Front, 4 ins.; sides, 5 ins.; back, 4 ins.
 Driving Wheels—Diam. outside, 68 ins.; journals, main 9x12 ins.
 Wheel Base—Driving, 13 ft. 4 ins.; total engine, 24 ft. 8 ins.; total eng. and tend., 53 ft. 10 1/2 ins.
 Weight—On driv. wheels, 132,110 lbs.; on truck, front, 44,290 lbs.; total engine, 176,400 lbs.; total engine and tender, about 306,000 lbs.
 Tender—Wheels diameter, 33 1/2 ins.; journals, 5x9 ins.; tank capacity, 7,000 gals.

Railway Machinery at St. Louis Exhibition.

The St. Louis Exhibition promises to be particularly valuable in the display of railway appliances. We understand that William Sellers & Co. will have the testing plant for locomotives installed in good time for the interesting experiments with locomotives to be conducted by the Pennsylvania Railroad Company.

Twelve locomotives of various types

wheels, and having sufficient capacity to absorb continuously the maximum power of the locomotive, and a traction dynamometer to indicate the pulling force of the locomotive, is the most complicated and intricate part of the plant. In these tests which involve an amount of running equivalent, approximately to 100 miles, weighings are made of the fuel burned and the water evaporated; while the quality of the steam in the boiler, the smoke box temperature and the loss of fuel in the form of sparks are all accurately determined. Speed and pressures are observed and recorded, and the power developed in the cylinders and the pull exerted at the drawbar are measured by the dynamometer.

The Influence of Brain Power on Dividends.

"It is necessary for the corporation, like the nation or individual, to be a

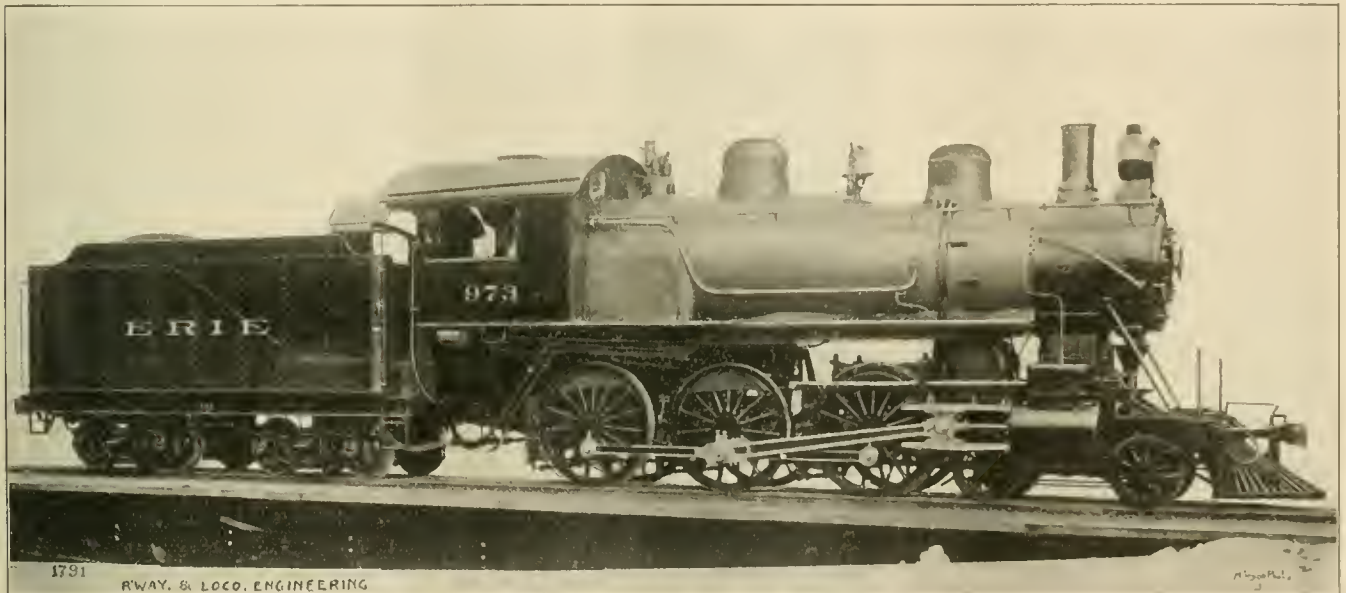

BALDWIN PASSENGER 4-6-0 FOR THE ERIE.

The boiler, which is of the wagon top type, has the gusset sheet in the second course. The outside diameter at the smoke box end is 64 ins. and the boiler is 73 1/2 ins. in the waist. The flues are 15 ft. long and there are 301 of them. The heating surface is made up as follows: fire box, 155.2 sq. ft.; tubes, 2,349.3 sq. ft.; water tubes for brick arch, 19 sq. ft.; total, 2,523.5 sq. ft. The roof sheet is level, while the crown sheet is slightly lower at the back end. An average steam and water space of about 18 ins. lies between them.

The tender has a water bottom tank and has a capacity of 7,000 gallons; the frame is made of steel channels. Some of the principal dimensions are as follows:

Boiler—Thickness of sheets, 1 1/8 and 3/8 ins.; working pressure, 200 lbs.

will be provided for these tests. Of these three will be furnished by the Pennsylvania Railroad—two, a freight and a passenger engine, being built at the Altoona shops, while the other will be a De Glehn locomotive, purchased by the company in France. Two of the testing locomotives will be furnished by German locomotive builders, and the other seven of American manufacture by other railroads.

The spectacle of the running of a locomotive at a speed of 80 to 100 miles an hour under its own steam without moving from the spot will be novel in the extreme. The plan of mounting the locomotives involves supporting wheels carried by shafts running in fixed bearings to receive the locomotive drivers and turn with them; brakes mounted upon the shafts of the supporting

student." This piece of good, honest speech occurs in a paper recently read by Mr. A. Bement, of the Bement-Pond-Niles Company. The speaker told his audience that the subject of his paper was suggested by the title of Captain Mahan's well known work, "The Influence of Sea Power on History," and also by the presidential address of Sir Norman Lackyer to the British Association for the Advancement of Science, in which that gentleman spoke of the Influence of Brain Power on History.

The nation having the largest navy exerts the greatest influence on political history and the nation best educated in science and business will naturally lead in industrial achievement. So it is with the corporation, and to attain this

end the corporation must become a student.

The corporation, however, has to work through its employees, and as a rule, under present conditions these have all they can do to attend to their routine duties and this leaves no time to devote to concentrated thought or original inquiry. This state of affairs makes an opportunity for a new and special kind of worker which Mr. Bement aptly called a professional student. Such a man, he said, should not be hampered with any routine duties at all, but should be left free to carry on his work without interruption or hindrance, and instead of working under the direction of some particular official, he should work with the assistance and cooperation of all.

The man capable of filling this position would require to be one possessed of good judgment and of an analytical habit of mind. The speaker did not regard the mere statistician as a suitable person and he ruled out the man who presents a solution of a problem before he understands it. The

there is no slip. Careful tests show that the indicated horse power transmitted by the belting average, on trial, per one inch width of belt a horse power, a speed of 200 ft. per minute; it would seem that a liberal factor of slip should be allowed outside of this.

Handy Appliance for Moving Tenders.

In the new tender shop of the Rogers Locomotive Works, of Paterson, N. J., there is a handy rig for moving the tenders in and out of the shop, and it is as simple as it is effective.

Some of the columns in the shop are steel and to the one opposite the door there is attached a power operated windlass, and it is bolted to a bracket overhead and is out of the way. There is first of all a countershaft which is attached to the main line shafting of the shop by means of a belt and a fast and loose pulley. The countershaft carries a 5 in. pinion which engages with a large gear wheel about 37 ins. in diameter. This large wheel turns a shaft carrying a wooden drum upon which is wound

we cannot say, but there is no doubt that Mr. Kellogg told the members of the Pacific Coast Railway Club some home truths, in his address. He took the case of a locomotive blowing off. He said it would astonish the average railroad man if told that this form of waste, if saved, would be sufficient to pay the salaries of the President of the United States and his Cabinet. He believes that a twenty-five per cent, increase in the output of machine shops of the country is possible; that a reduction of twenty-five per cent. in the cost of operating railway stationary plants can be had; that the cost of delivering coal from cars to tenders can be reduced over fifty per cent., if the best appliances be adopted as standard; that fifty per cent. of the lubricating oil used never reaches a bearing; that the losses in other ways would, in a short time, pay the national debt or what would probably be more acceptable, double the wages of every railroad man and still give the stockholders larger dividends than ever they had before. If these things were observed and the remedy applied, it would be a happy day for railroad owners and their operatives.

In order to make this clear Mr. Kellogg took a fancied excursion party on an imaginary trip over several very real, though unnamed, railroads. He says, we find near the shons of one of them six flagmen imperfectly protecting street crossings in a city, their wages aggregate \$9.00 per day. One man in a tower can operate pneumatic gates at a cost of \$3.00 a day—this would save \$6.00 per day. Again, he instanced a small road owning 100 engines, one-third not being up to date. Their performance sheet, he assumes, shows each engine is costing two cents per mile more than better designed engines would cost. When it comes to making one and three-quarter million miles as this poor power has to, the extra two cents represents a loss of \$35,000 a year. A well equipped modern coal chute with everything in good shape, handles coal for six cents per ton less than the average railway coaling station. Many railroad systems use five hundred thousand tons of coal per annum and six cents saved on handling this amount of coal means a total saving of \$30,000 per year.

When it comes to machine tools the listener, on this personally conducted tour, was invited to contemplate a railroad with first class rolling stock, superb limited trains, and at the same time working along with inadequate shops and antiquated machinery. Mr. Kellogg said in this kind of a shop two men operated single ended axle lathes at a loss of \$2.50 per day. The absence of traveling cranes and drop pits makes an estimated loss of \$10.00 a day. Old fashioned shop tools were re-

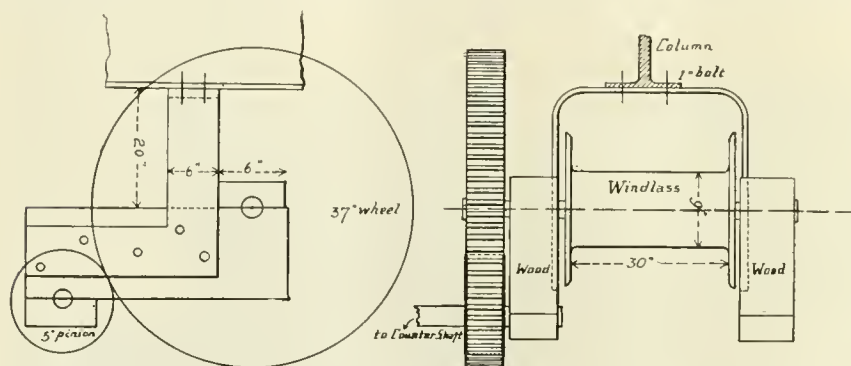

APPLIANCE AT THE ROGERS WORKS FOR MOVING TENDERS IN THE SHOPS.

work which this professional student should do would be to investigate, study and discover the solution of recognized problems as well as the invention of new schemes and methods. The field for such work he held to be unlimited and its possibilities but little realized.

Mr. Bement admitted that there were difficulties in the way of the realization of this scheme. The general disposition to regard the period of studentship as something to be as quickly outgrown as possible must be laid aside if the professional student is to have a chance. The assumption that a sufficient working knowledge has been acquired, too often survives with the result that obsolete methods and reasoning largely prevail.

To Calculate the Speed of a Belt.

To find the speed a belt is traveling per minute, multiply the diameter in feet of either pulley by 3.7 times its revolutions per minute; the result is the feet travel of belt per minute if

a goodly length of 1 in. manila rope. Our sketch gives an outline of the apparatus.

There is a pulley at the bottom of the post which is used to change the vertical pull of the rope to a horizontal one along the shop floor. There is a snatch block at the door and another at the far side of the shop, and these blocks determine the direction of motion. When a tender has to go out of the shop the rope is passed back through the lower pulley and through one of the snatch blocks and is attached to the tender which then goes out of the shop on the dead run.

Intelligent Observation Properly Applied.

"He who realizes possibilities and acts on this realization will ultimately become a leader." This is the opening sentence spoken by Mr. W. L. Kellogg in a paper he recently read on the subject of applying the results of observation.

Whether or not it is always the case

sponsible for a further loss of say \$9.00 a day. Keeping antiquated tools at work which could have been replaced with modern machines, added to the loss. An idea of the style of place Mr. Kellogg had in mind may easily be imagined when he says, "men carried tallow candles and walked one hundred yards to the store-room every time they required a new one." The tabulated losses in such a shop he estimates at \$57.00 per day, and this amounts to \$20,805 in the year.

We rather imagine the speaker at that club meeting touched the hearts of his

the roadway, the bridge builder, the track walker, the engine inspector, the engineer and brakeman, the conductor and brakeman, and all others intimately acquainted with their work in hand, and extract from them the value of intelligent observation.

Unloading Rails With Compressed Air Apparatus.

Rolling mills very frequently ship rails in gondola or deep steel cars and when the unloading comes to be done the rails have to be lifted up over the

kind of car having open sides. The bases of the uprights are made so as to rest on the top of the car, which relieves all vertical strain on the pockets. There is a roller permanently secured to the inside of each of the posts and placed about 10 ins. above the top of the edge of the car side. Another pair of rollers, each forming part of one of the inclined ways, are hooked over the car ends. These rollers are in line with the ones on the uprights.

The inclines or slides are made like a pair of channels with two angle irons bolted to a stout plank. Their lower ends rest on a small stick of timber about 5x5 ins. placed across the rails of the track. This timber is held in place by a pair of hooks one in each of the channel ends. The timber is mounted on two small wheels which run on the railway track and permit of the inclined ways being drawn along when the car is moved.

Four men are required to operate each of the air cylinders. Eight men, therefore, unload two rails at the same time. Rail tongs are suspended from the lower ends of the piston rods of the air cylinders, and after the tongs of one of them has gripped a rail the rail is raised a sufficient height to allow men to guide it to the roller which is attached to the upright post, and also to the roller at the head of the slide. When this has been done, air is released, and the tongs let go. The rail is then started toward the incline and when the center of the rail reaches the roller at the top of the incline the rail tips up and slides quickly down, without danger of doing damage to itself. The men do not do any lifting; that is done by the hoists, the air for which is taken from the train line and brought to the suspended cylinders through a flexible hose.

As soon as two rails have been unloaded the whole train moves on and the loose rails continuing to slide down the incline eventually place themselves on the ties just outside the track rails. When the load has all been removed from a car, the apparatus is easily transferred to another on the road and the empty placed in a side track. The operation of rail unloading is rapid, easy and regular.

A Long-Distance Call.

Our telephone number is 3163-L. We have a purely English housemaid who attends the needs of the telephone. The other morning the following colloquy was heard:

"Central, give me Plumley."

"Who are you?"

"3163-Hell."

"What do you want?"

"Send a 'ack in time for the hait two-train."

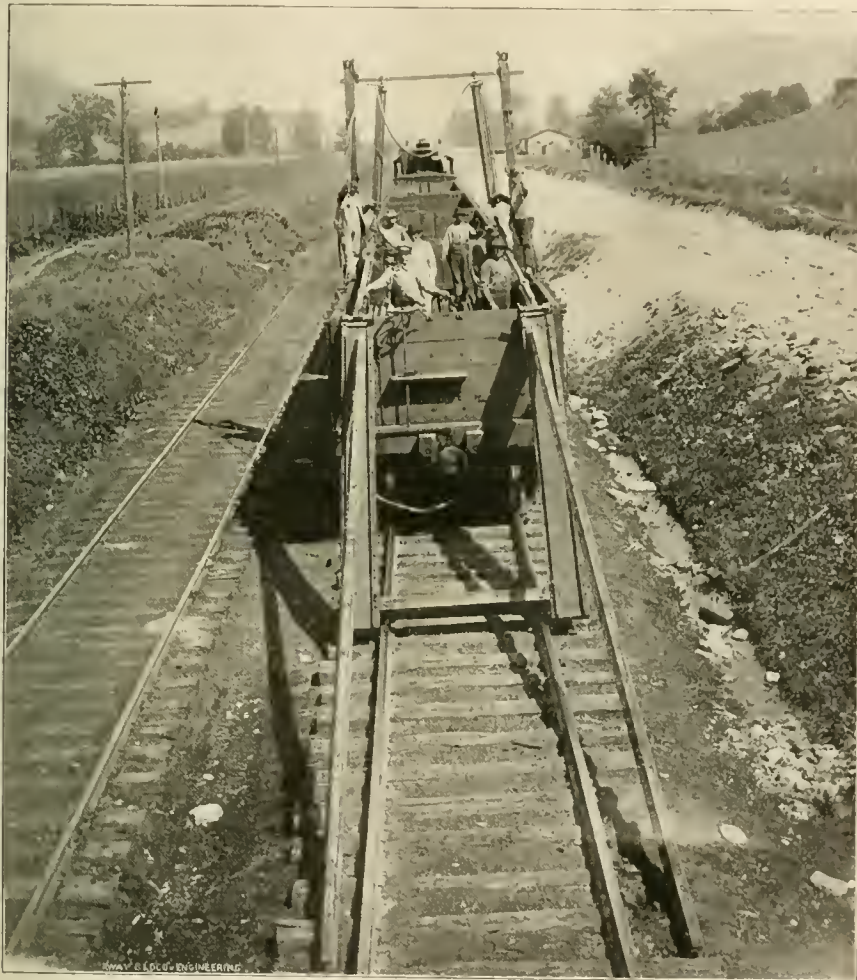

UNLOADING RAILS FROM GONDOLA WITH AIR HOISTS.

auditors when he pictured a busy divisional point with a hand power turn table, two men constantly at it and a cost of \$8 per day. That is \$2,888 per year. If half this sum were saved, as it might be, by equipping the table with some kind of a motor and having the hostler turn the engines, it would represent a net saving of \$1,444 per year.

Thus did the master mechanic of the Missouri Pacific point out these and other expensive methods of working which are yet to be seen, perhaps not all at one point, but which have a real existence none the loss.

Let us, he concludes, make more experiments; let us call in the expert of

sides, and either handled or thrown to the ground. Mr. Henry Ware, roadmaster of the Buffalo, Rochester & Pittsburgh Railway, Springville, N. Y., has devised an air operated apparatus which will do the lifting quickly and surely, and the saving of time here means the saving of money for the company.

The apparatus consists of two upright posts which support a bar of round iron from which hang two pneumatic hoists of ordinary form. The upright posts of the frame are secured to the sides of the car by an adjustable stake pocket and two adjustable brace rods, so that it can be placed on any

A New Petrol Locomotive.

The locomotive here illustrated has been designed and built by The Maudslay Motor Company, Limited, of Coventry, England, to the order of The City of London Corporation, for the special purpose of drawing freight cars between the Corporation Meat Market and the London, Brighton and South Coast Railway sidings. The full load consists of four cars, weighing when loaded about fifty tons. The maximum gradient is exceedingly stiff, being 1 in 36. The rails are of standard gauge. As the line to be traversed runs partly through the streets and partly in the Market, the locomotive is geared to travel at a slow speed only, and has two speeds in each direction of $2\frac{1}{2}$ and 5 miles per hour respectively.

The motor is similar in design to the Maudslay Motor Company's standard pattern, and has three cylinders, 9 inch bore by 9 inch stroke, and develops 80 b.h.p. at 450 r.p.m. Half compression cams are fitted, and for greater con-

ent that it would have been capable of drawing the same load at a much higher speed or a much heavier load at the same speed. The trial included stopping and restarting on the steepest gradients. The running of the locomotive, and especially the ease with which it was controlled and reversed, gave complete satisfaction to all parties concerned, and those present to watch the trial signified their entire approval.

Steel vs. Iron—A Night With a Ghost.

BY GEORGE RICHARDS.

Clothed with authority from the New England Railroad Club (where the story was read) we employed an expert as courier and interpreter, invoking the aid of old Vulcan, the god of fire, the worker in metals, the blacksmith who forged the thunderbolts, and commenced our journey of investigation.

With him we were wafted over the land and over the sea, he leading us on back past the time of old Tubal Cain, to the period when time was young, if

forth a mixed odor of tobacco and sulphur. The same pale moon sheds its beams on the wild desolation that shone on the busy multitude 6,000 years ago.

We call to mind the words of Tennyson,

These little systems have their day;
They have their day and cease to be.

Here the spirit of the departed blacksmith ended our reveries, and in my wakeful hours I still hear that hollow sounding voice saying: "There is no peace for the wicked." Then he surprises us with the statement, that in all these long centuries and down to the present time, not one large piece of wrought iron had been made that was assuredly sound. Interrupting him and asking for his authority for the statement, he replies: "Heaven hides from men what spirits know."

We, humbly apologizing for presuming to doubt the statements of our guide, he continued, and enlarged upon the patience and perseverance with which mortals have studied this question, seeking by some means to make iron homogeneous; but, like the seekers after the elixir of life, without avail.

Then he tells the story of the early production of steel by the cementation process, the surrounding of bars of a known quality of iron with carbon and heating them to a combining temperature, thus changing them to blister steel, after which they were forged to the desired shape. Seeking for something better, bars of blister steel were broken up into short pieces, each piece carefully inspected, and then melted in crucibles and cast into ingots. This he informs us is substantially the crucible process of to-day, and has for years been unequaled when perfection has been desired regardless of cost.

Then his ghostship talked of the recent discoveries in steel making, the Bessemer, open hearths, basic and others which have followed them and of the struggles for existence; of the progress made in their introduction; by the conversion or death of their opponents; of the introduction of steel rails with an endurance equal to ten times that of iron, due to the homogeneity not possessed by iron; of the superiority of steel tires from the same cause; of boiler plates free from lamination, and of locomotive frames cut from large bars, thus avoiding the annoyance through the failure of welds.

Then he spoke of the failure of steel where iron or steel was sure to fail through very bad design, of the great steamer shafts of iron which are broken in one year's service, then replaced with steel, in the vain hope that they would endure forever; of the general progress made in the manufacture of steel and the ability of the makers now to satisfy any reasonable demands at reasonable



BRITISH GASOLINE LOCOMOTIVE.

venience an 8 h.p. single cylinder engine is fitted for starting purposes.

Westinghouse brakes are fitted in addition to the ordinary hand brakes, also a sanding apparatus for use when the streets are greasy.

The water and petrol tanks are of sufficient capacity for a whole day's work, and the motor is cooled by a large tubular radiator fitted with a fan. The mechanism is all covered in from view to conform with Board of Trade regulations. The weight of the locomotive complete is about twelve tons.

The official trial of this locomotive took place on February 29, when a large number of influential gentlemen were present. The cars shown in the photograph were loaded with paving stones to bring them up to the contract weight (fifty tons). The locomotive drew the train all over the system with perfect ease, and it was evident to those pres-

ever such there was; led us up to the pyramids and the sphinx, still repeating the story of iron and steel; led us through the forests of India; told us of the large iron columns found there, forged by those whose race is long since extinct; on to old Damascus, the city which has looked upon the rise and progress of all that we know of the human race, of its working in metals now as it has done for centuries. Then to Baalbec, that old ruin whose history is unwritten; showing us the stones of nearly 1,000 tons weight, raised on columns 90 feet high, in the preparation and erection of which iron and steel played a prominent part; telling of the old ruins in which the stones were fastened together by iron crabs, which were coated with lead to prevent corrosion.

And now, weary with our long journey, we sit down among the ruins for a rest, fill and light our pipes, which send

The Master of the Situation

No man has need of a clearer brain than the driver of a locomotive. He must be freed from every care and anxiety, to give his whole time and thought to the safety of his passengers and *to make speed*. He must be complete master of the situation every moment, for delay and hesitation and uncertainty may have awful results.

With a laboring, groaning engine and an immovable lever; with a cranky, sticking air-pump, or hot-pin almost burning up; with any of the annoyances that come with poor lubrication and when things go wrong in spite of him, how *can* an engineer give his time and thought to the track ahead?

It was to free themselves from this strain that the Engineers first took to using

DIXON'S FLAKE GRAPHITE

as a cure for friction troubles.

It was to save wear and tear on locomotives, repairs, delays and accidents, as well as coal and oil, that the Railroad Companies took to providing it regularly.

If interested in the cure of lubrication troubles, write for Booklet 69-c and a free sample.

**JOSEPH DIXON
CRUCIBLE CO.
Jersey City, N. J.**

prices; of the tests of tensile strength and ability to withstand vibratory or any other strains much better than iron, and in fact being what the world has wanted for a thousand years.

Then followed a dialogue as follows: Are there any considerable number of broken cast iron driving wheel centers on the American railroads? Answer—The number is surprisingly large.

What is the remedy? Answer—Use steel castings.

Can they be made sound? Answer—As much so as iron, if of good design. All ingots from forged or rolled steel are first cast, and if faulty, the defects exist in the rolled or hammered goods, whether they are plates, bars or rings like tires, yet defects from this cause are infrequent.

Is the strength of steel castings greater than that of iron? Answer—Very much so. They are rapidly taking the place of iron castings, and in many cases of iron forgings. The governments of the principal nations of the world are using them very largely, some of them used weighing several tons. They are required to pass very rigid inspection, and are rejected for very slight defects. Many of the best steamship and railroad companies are already wedded to their use. A representative of a prominent railroad says in a recent letter: "We are using steel castings for driver brake shoes, piston heads, driving boxes and various other parts of locomotives and intend using steel driving wheels, and are only waiting for some party in America to make perfect castings." Another says: "The wheel centers used by me are steel castings." Another says: "We are using steel castings for centers of driving and other wheels of locomotives and tenders, also use steel castings for other parts such as motion brackets and axle box slides." Another says: "We are using steel castings for driving wheel centers and to a very large extent for other parts, and the results are satisfactory." Another says: "We are using steel castings for driving wheel centers and parts generally." Another says: "We are using steel castings for driving wheel centers and on locomotives generally wherever we can; they are very satisfactory." Another says: "We have 1,600 cast steel driving wheel centers in use and are using steel castings for all parts of engines where cast iron was formerly used except for cylinders."

Venetian Railway Signaling Invention.

In a recent consular report to the United States Government, Mr. Alexander Thayer, vice consul at Venice, speaking of a new railway signaling apparatus exhibited there, says:

"A special train carried the guests

from Padua to Castelfranco, where, upon arrival, the operation of the new system was demonstrated by means of a miniature electric railway constructed in a freight house opposite the station, and which, when explained by the inventor (Mr. Attilio Beer, a Venetian engineer) showed in a clear and detailed manner the method whereby notice is given to the men on a locomotive in motion when there is another locomotive on the same track within a distance of half a mile.

"The apparatus itself was tested in all its particulars and exhibited such a complete and timely method of giving warning of the proximity of another train that should it prove practical when applied to entire railroad systems, Mr. Beer's invention would reduce to a minimum the large loss of life and property which is now annually due to collisions.

"Another feature was also shown, namely, a dial which can be placed in railway stations and offices of train dispatchers. This dial indicates the exact position of all trains on the line within a certain distance, and whether they are stationary or in motion. The usefulness of such an instrument is readily seen, as by means of its notification of an obstructed track is at once given by the indicator."

The second edition of catalogue No. 115, the general condensed catalogue of the B. F. Sturtevant Co., Boston, Mass., is now ready for distribution. This catalogue describes and illustrates a number of new apparatus manufactured by this enterprising company, among which are: a new type of hand-blower; several new types and sizes of forges; new sizes of vertical single and double engines; a new type of enclosed vertical compound engines; new type of semi-enclosed bipolar and 4-pole motors; new sizes of generating sets with vertical compound engines; factory equipments, such as bench-legs, pattern storage shelf brackets, electric hoists, cast iron sinks, trench cover-plates, etc.; industrial railway equipments, such as cars, truck ladles, turntables, T-rails, etc. It also contains a description of the various Sturtevant systems, such as heating and ventilating, special ventilating, drying, conveying, and mechanical draft systems.

How to Polish Brass.

We have been successful in polishing brass with the following solution: To 2 quarts of rainwater add 3 ounces powdered rotten stone, 2 ounces pumice stone, and 4 ounces oxalic acid. Mix thoroughly, and let it stand a day or two before using. Stir or shake it up when using, and, after using, polish the brass with a dry woolen cloth or chamois skin. The more thoroughly the brass is rubbed the longer it will stay bright.

The New York Compensating Valve.

(Continued from page 219.)

With the packing rings practically air tight and the joint between the body and the spring box of the valve the same, care should then be taken to see that the plug which screws into one of the check valve holes in the spring box is air tight; that the check valve itself where it screws into the spring box is air tight, and also that the seat of the check valve is screwed in tight into the check valve case; and finally that the lock nut H.S. 13a is screwed up tight, making an absolutely air tight joint.

These things looked after carefully, an air tight chamber is provided underneath the piston consequently, whenever air is vented in emergency applications, by the New York quick action triple, into this chamber the maximum brake cylinder pressure obtainable from a reservoir pressure of 110 pounds, which, with piston travel closely adjusted, is 85 pounds, will be held for several seconds in the brake cylinders, before the valve opens to relieve it.

In Fig. 1, March number, end view of compensating valve showing the arrangement of piping, the 1/2 in. pipe connection between the brake cylinder and the body of the valve should always be absolutely air tight. This pipe connection after it is made should be given the usual soap sud test.

The 1/2 in. pipe connection from the side cap of the triple valve to the non-return check valve and spring box should be securely tight, but as will be readily seen from a little study of the figure need not be absolutely air tight, and will not require any special test after it is once securely fastened.

Before being put on, these pipes should be blown out carefully removing all dirt and fins.

Should port J be blocked up what would be the result, is a question sometimes asked. If this port became blocked the tendency would be to retard the escape of air from the chamber, which would delay the opening of the relief ports, and the maximum equalized pressure, in emergency applications only, would be retained for some seconds longer than usual. In service applications should port J be blocked up, it would make no difference whatever with the operation of the valve.

Should the check nut H.S. 13a become loose or fall away the valve would then operate the same as on a plain triple.

J. W. KELLY.

Watertown, N. Y.

Air Brake Patents.

My attention has recently been called in the Patent Office Gazette to the numerous patents which have been taken out by air brake men on air brake de-

vices. The major part of these patents are taken out on triple valves which will recharge the auxiliary reservoir while the brake remains set. Others are for automatic retaining valves, etc.

It would seem that while a person is seeking things to patent he would do well to place his mind on matters which would really be of benefit to the air brake world. These patents should be on devices which give improved results over those obtained at the present time, and should not be so essentially different that they will not work in harmony with the present devices. The latter feature is one of the strongest features of the patents gotten out by Mr. George Westinghouse. The plain automatic brake worked in harmony with its successor, the quick action brake, and the high speed brake works in harmony with its successor, the ordinary quick action brake.

According to the writer's way of looking at it, one of the best directions toward which an inventor may turn his mind, is that in which our long freight train service will be benefited by less shock to lading and to numerous break-in-tuos. The latter has been largely reduced by the straight air brake on the locomotive and tender, which holds in the slack while the automatic brakes on the train are being released and recharged; but this straight air brake on engine and tender alone is not sufficient for the purpose, although it is in the right direction. It would seem, therefore, that herein lies the future and successful field for the inventor.

It is not usually known, but it has been said, that "Any person can get a patent on almost anything, if he secures the right patent attorney." There is a great deal of truth in this, as many of our inventors can attest; for there are numerous air brake men throughout the country who have spent their good money on patents which they were assured would amount to a great deal and were encouraged in doing so by unscrupulous patent attorneys, yet these patents are worthless, several inventors having almost the same thing. In order that a patent be valuable there must be a demand for it. It is true that "Necessity is the mother of invention." There are only too many men inveigled into a patent and made to believe that it is a world beater and will result in large financial advantage to themselves, when actually the patent is not worth the paper it is written on.

A man who gets a patent on an air brake device is not at once on the high road to wealth. He must have in his device something which the railroad or brake company needs and wants. No matter how excellent in the inventor's mind the device may appear, it actually has no real value until a buyer needs and wants it. Again, a novice too often

GOLD CAR HEATING AND LIGHTING COMPANY

Catalogues and Circulars Cheerfully Furnished

MAIN OFFICE
WHITEHALL BUILDING, 17 BATTERY PLACE
NEW YORK

BRANCH OFFICE
THE ROOKERY
CHICAGO

Manufacturers of ELECTRIC, STEAM AND HOT WATER APPARATUS FOR RAILWAY CARS

JUST PUBLISHED

New York Air Brake Catechism

By Robert Blackall. The only complete treatise on the New York Air Brake and Air Signaling Apparatus, giving a detailed description of all the parts, their operation, troubles, and the methods of locating and remedying the same. Including and fully describing and illustrating the Plain Triple Valve, Quick-Action Triple Valve, Duplex Pumps, Pump Governor, Brake Valves, Retaining Valves, Freight Equipment, Signal Valve, Signal Reducing Valve, and Car Discharge Valve. 250 pages. Price, \$1.25.

Locomotive Catechism

By Robert Grimshaw. 23d Edition. Is right up-to-date and contains twelve large Folding Plates and 1,600 Questions and Answers on How to Run a Locomotive. The Standard Book on the subject, being written in plain language and free from mathematical formulæ and complex problems. Endorsed by all Railroad Journals. Price, \$2.00.

18TH EDITION OF Air Brake Catechism

By Robert H. Blackall. Just issued. Entirely rewritten, revised and enlarged. Contains 1,500 Questions and their Answers on the Westinghouse Air Brake, which are strictly up-to-date. Includes two large Westinghouse Air Brake Educational Charts printed in two different colors. The latest practical work published. Endorsed and used by all Air Brake Inspectors and Instructors in the United States. Send for a copy and get posted on How to Handle Air Brakes. Price, \$2.00.

Combustion of Coal and the Prevention of Smoke

By Wm. M. Barr. Contains over 800 Questions and their Answers on The Science of Steam Making. Price, \$1.50.

Locomotive Breakdowns and their Remedies

By Geo. L. Fowler. Just issued. Tells how and what to do in case of an accident or breakdown on the road; includes special chapters on Compound Locomotives. Better procure a copy, as it contains 800 questions and their answers on accidents and breakdowns. Price, \$1.50.

Don't wait until the day of examination comes, but send immediately for the above books, as they contain many Questions and their Answers asked by the examiner on your road.

Send for a special circular describing the books in full. Any book sent prepaid on receipt of price.

AGENTS WANTED.

Write for Particulars.

The Norman W. Henley Publishing Co. 132 Nassau St. New York, U. S. A.

conceives a belated idea, although it is new to him, and he rushes to some patent attorney with it before anybody discovers his secret. This man later on has the same cause to regret his action as the Eastern man who went West to introduce the game of poker to the Westerners.

HARRY E. GONTHERS.

Wilmington, Del.

Some Troubles With the Straight Air.

We have experienced some trouble with the combined automatic and straight air brake, but upon investigation it has been found that these troubles are principally due to the wrong location of the double seated check valve, and I give it

this is done the air will blow past the spool valve and out at the exhaust port at the triple. The brake will also be slow in releasing.

Fig. 3 shows the valve working in a horizontal line. In this position gravity has no effect upon the valve so far as the

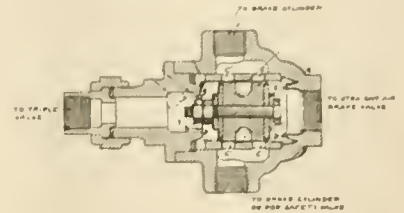

RIGHT POSITION—HORIZONTAL LINE.

seat is concerned, and the result is that the valve will move freely in either side direction, and will not strike hard on the gasket seat.

Fig. 4 shows the valve in a reversed position to that in No. 3. In either of these latter positions the valve will work O. K.

C. E. HAINES.

West Philadelphia, Pa.

Some Flat Wheels.

Steam railroads which have been troubled with slid flat wheels during the past winter should take a grain of comfort from the following extract from the report of the New York State Board of Railway Commissioners, which reads:

"The operation of cars with flat wheels causing annoyance to residents has been taken up with the various

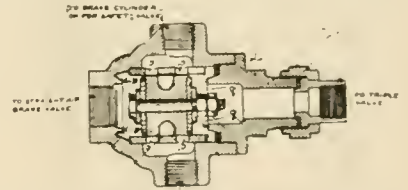

RIGHT POSITION—HORIZONTAL LINE.

to your readers for what it may be worth. This check valve is sometimes placed in a perpendicular position, which is wrong. The valve should always be placed horizontally.

Fig. 1 shows the check valve placed in the vertical position. It will be seen that the spool valve will be acted upon by gravity, and it will drop to the lowermost position.

Fig. 2 shows this same valve, but in an inverted position. In this position gravity acting upon the spool valve causes it to drop against the lower seat. The chief objection to the vertical posi-

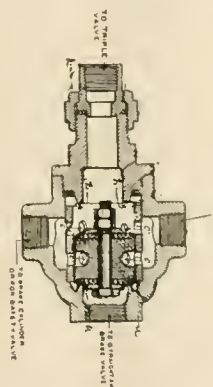

WRONG POSITION—VERTICAL LINE.

tion is that when air is admitted to the under side of the spool valve that the valve will be forcibly thrown upward against the upper seat, the gasket there-by being pounded out and injured. When

companies and a more thorough inspection and removal of flat wheels has been ordered by the Board. During the quarter ending November 30, 1,367 pairs of new wheels were placed under the electric cars of the Interurban Company. During the same period 1,659 wheels were placed under the cars of the Brooklyn Rapid Transit Company.

When flat wheels become so numerous and bad as to keep residents awake along the line, the cause should be diligently sought and remedy effectively applied. One disturbed resident objects to the pound of flat wheels as "an unceasing, bumping sound calculated to arouse even a policeman from his sleep."

Only they who do their duty in everyday and trivial matters will fulfil them on great occasions.—Charles Kingsley.

Handy Lathe Appliance.

I send you herewith a little shop kink I have just made for turning up dowell keys for crosshead and knuckle joint pins.

In the month of January we applied forty knuckle joint pin keys; it has been the practice to finish these keys up with a file in the vise, which requires considerable skill and time. The little trick shown here will be easily understood. A is turned to fit live center hole in head stock of lathe, the knuckle pin keys are drop forged to sizes as shown at B; they are then placed in slot C, point D resting against end of slot at E, which brings F in position to run true. Key is held in place by tightening cap screw G. The round part of key is then turned to size. Side H of key also being faced square at the same setting. It takes the machinist at the vise 12 minutes to fit one of these keys, while the apprentice

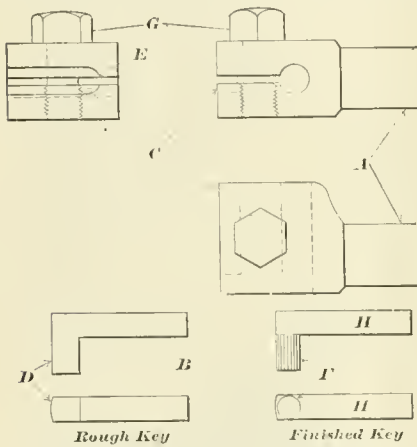

TOOL FOR TURNING KNUCKLE JOINT AND CROSSHEAD PIN KEYS.

boy can do one in the lathe, with this tool, in three minutes. The time saved on forty keys is six hours. Money saved on forty keys, \$2.79. Machinist is paid at 38 cents per hour. Apprentice, at 12½ cents per hour.

J. B. PHILLIPS,
Machine Shop Foreman, A., T. & S. F.
San Bernardino, Cal.

Simple Tests for Water.

Boiler users who desire simple tests for the water they are using will find the following compilation of tests both useful and valuable:

Test for Hard or Soft Water—Dissolve a small piece of Castile soap in alcohol. Let a few drops of the solution fall into a glass of the water. If it turns milky, it is hard water; if it remains clear, it is soft water.

Test for Earthy Matters or Alkali—Take litmus paper dipped in vinegar, and, if on immersion the paper returns to its true shade, the water does not contain earthy matter or alkali. If a

few drops of syrup be added to a water containing an earthy matter, it will turn green.

Test for Carbonic Acid—Take equal parts of water and clear lime water. If combined or free carbonic acid is present, a precipitate is seen, to which, if a few drops of hydrochloric acid be added, effervescence commences.

Test for Magnesia—Boil the water to twentieth part of its weight, and then drop a few grains of neutral carbonate of ammonia into a glass of it and a few drops of phosphate of soda. If magnesia is present, it will fall to the bottom.

Test for Iron—Boil a little nutgall and add to the water. If it turns gray or slate black, iron is present. Second: Dissolve a little prussiate of potash, and, if iron is present, it will turn blue.

Test for Lime—Into a glass of water put two drops of oxalic acid, and blow upon it. If it gets milky, lime is present.

Test for Acid—Take a piece of litmus paper. If it turns red, there must be acid. If it precipitates on adding lime water, it is carbonic acid. If a blue sugar paper is turned red, it is a mineral acid.

Test for Copper—If present, it will turn bright polished steel a copper color. Second: A few drops of ammonia will turn it blue, if copper is present.

Tests for Lead—Take sulphureted gas and water in equal quantity to be tested. If it contains lead, it will turn a blackish brown. Again: The same result will take place if sulphate of ammonia be used.

Test for Sulphur—In a bottle of water add a little quicksilver, cork it for six hours, and, if it looks dark on the top, and on shaking looks blackish, it proves the presence of sulphur.

The Falls Hollow Staybolt Company, of Cuyahoga Falls, Ohio, have issued a little pamphlet on the subject of Railway Motive Power Expenses. Three aspects of the case are dealt with, Broken Staybolts being the first, Bad Water comes next and Imperfect Combustion is the third. The pamphlet is written by Mr. John Livingston of Montreal, the Canadian representative of the company. In addition to the writer's own experience and observation in these matters there are numerous quotations from the utterances of prominent motive power men, when speaking at railway club meetings, etc. The little book also contains the results of some laboratory tests made of Falls Hollow Staybolt Iron and samples of other staybolt irons. The reader cannot fail to get some useful information and food for thought, by a perusal of this careful little review of the three chief factors always active in causing working expenses on railroads. The Falls Hol-

Do You Boil Glue?



ARMY & NAVY LIQUID GLUE

does away with this work. A pure hide and sinew glue in liquid form. No smell; clean and convenient. Will reduce your shop expense for this line of work twenty-five per cent. **The Glue of the Twentieth Century.** Put up in cans, kegs and barrels.

Not a Fish Glue

Samples for testing and prices are yours for the asking.

WACHTER MFG. CO.
BALTIMORE, MARYLAND

Keep Your Mind On It



CRANDALL'S HELIOS AIR PUMP and THROTTLE VALVE

PACKING

Put Up in Sets
Exact Fit to Rod and Box
Send Trial Order

The Crandall Pkg. Co.
123 Liberty Street
N. Y. CITY
Chicago Office, 30 La Salle St.

low Staybolt Company will be happy to send the pamphlet to any one who wants to read about staybolts, and who will write and ask them for a copy.

The J. A. Fay & Egan Company, of Cincinnati, Ohio, have issued a catalogue of the second-hand machinery which they have in stock at present and which they are ready to dispose of at reduced prices. The list gives the number of the machine and the price. Each machine is adjusted thoroughly, every part is put in first class working order and tested in the works before being sent out. This company are manufacturers of high grade wood working machinery of all kinds. Write for the catalogue if you are interested.

Tate Flexible Stay Bolt.

The oldest person connected with the care of locomotives, does not remember a time when trouble with breakage of stay bolts has not been a source of danger, annoyance and solicitude. Broken stay bolts have caused more boiler explosions than any other source of weakness. The man who invents a device that will prevent the breakage of stay bolts deserves the gratitude of every person connected with the opera-

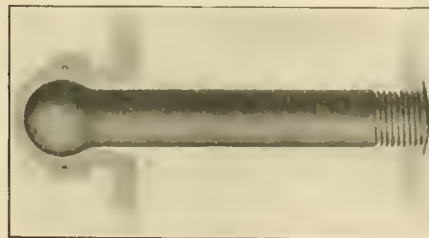

TATE FLEXIBLE STAY BOLT.

tion of locomotives, and of all other boilers that have surfaces which require staying. It seems to us that the inventor of the Tate Flexible Stay Bolt here illustrated, has met the long felt want and is likely to be a world's benefactor.

The cause of stay bolts breaking is the bending that results from the constant movement of the sheets due to changes of temperature. An arrangement that permits the stay bolt to keep its hold of the sheet without bending is certain to prolong the life of the stay bolt almost indefinitely. We see no reason why the Tate Stay Bolt should not last and perform its functions efficiently during the entire life of a fire box. We understand that a set of these stay bolts has been in service about five years under extremely trying conditions and that not one of them has broken. The design of the bolt is so plainly shown in our engraving that no description is necessary. Although the stay bolt has been but a short time

upon the market we understand that an active demand for it already exists. It is controlled by the Flannery Bolt Company of Pittsburgh, who have a large plant under construction for its manufacture, which will have an output of 10,000 bolts per day. A fine equipment of special tools will be employed in doing the work, the automatic tools being operated by electric drives.

The average life of stay bolts of the ordinary type in the danger zone is from ten to twelve months and the average cost per bolt to the Railroad Companies is from \$1.00 to \$1.25 per annum. The cost is arrived at by taking account of all things chargeable to stay bolts, viz.: Locomotive out of repair; dismantling of same; drawing fires; labor and material for the year; and dividing the total cost by the number of stay bolts installed.

Now as against this cost, the "Tate Flexible Stay Bolt," at a cost not exceeding 60 cents per bolt installed, will last without doubt the life of the fire box, and when the fire box has to be renewed the cap and sleeve of the bolt will be found to be in such good condition that they can be used again, and it will only be necessary to purchase another bolt, which can be supplied at a less cost than the present rigid bolt costs the companies. Those interested can thus see what an enormous saving it will be to use these bolts, besides the additional safety, and the fact of the locomotive being so much less time out of service for repairs, thus increasing the efficiency of the motive power to the amount now lost owing to stay bolt repairs.

The new catalogue of the Niles-Bement-Pond Company, of 136 Liberty street, New York, is a bulky volume, and moreover it is a work of art. It contains 750 pages and weighs about 10 pounds. The pages are the master mechanic's standard size, similar to those of RAILWAY AND LOCOMOTIVE ENGINEERING. The paper used is a heavy cream laid one, and the printing and half tones is excellent. The various machine tools made by this company include all sorts of railway machinery, such as lathes, planers, slotters, milling machines, drills, boring and turning mills, boiler and bridge shop machinery, steam hammers, electric traveling cranes, and numerous small tools. In getting out the catalogue, the company's aim has been to give terse descriptions and the more important dimensions of the machine tools made. The company will furnish to intending purchasers prices, weights and full specifications, together with data concerning any of their products even if not found in the book. Those who have been fortunate enough to receive



Over One Thousand Miles A DAY on "The Colorado Special"

Dinner in Chicago Today
Breakfast in Omaha Tomorrow Morning
Dinner in Denver Tomorrow Evening

SPLENDID TRAIN SERVICE to DENVER via UNION PACIFIC

Full information cheerfully furnished on application to
G. P. and Tkt. Agt.,
Omaha, Neb.

a copy have secured what is practically a book of reference on machine tools, etc.

Power Feed Sander.

The cut here shown is of a sanding machine especially designed for car works. It was patented March 20, 1900, and has embodied in it new points to insure it doing good work for those having fine sanding to do, as attested by many testimonials and letters from those who are using it.

The machine is invaluable where a perfectly smooth surface is desired, either for varnishing or painting. It is massive and substantial, and saves the work of several machines for doing this kind of work. The three steel polishing cylinders upon which the paper is placed have a vibratory motion to prevent the formation of lines, and are equipped with a device for quickly applying the sand paper and giving it the proper tension. Each cylinder carries a different grade of paper, the third cylinder giving the final and smoother finish.

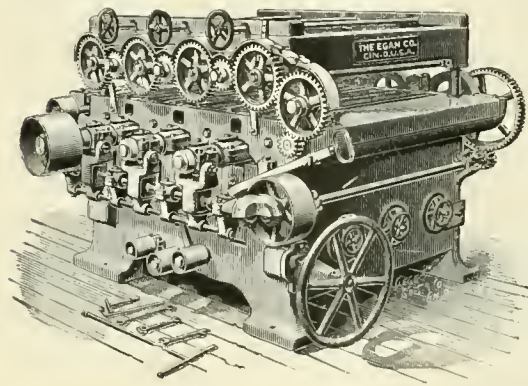

POWER FEED SANDER.

The feed is very powerful, and consists of eight feed rolls, four above and four below, driven by a train of heavy expansion gearing, and will open to receive material 8 ins. thick. The machine is made to work material from 30 to 80 ins. wide, and has a brush attachment which cleans the stock after it has passed through the machine. The pressure rolls are so arranged that the adjustments can be made easily, quickly and accurately, and the feed started and stopped instantly.

The makers of this improved sander, J. A. Fay & Egan Co., No. 445 W. Front street, Cincinnati, O., will be glad to hear from those interested to whom they will submit prices, information and cuts showing it in detail. They will also send free their new illustrated catalogue, showing their machinery to those who will write them for it.

The Allis-Chalmers Company, of Milwaukee, Wis., are on account of the rapid extension of their business becoming builders of gas engines, steam turbines,

hydraulic machinery and electrical machinery, in addition to the classes of output for which their several works have been for many years well known, such as reciprocating steam engines, pumping engines, rolling mill engines, blowing engines, mining machinery, flour mill machinery, saw mill machinery, rock crushing machinery, cement machinery, perforated metals, etc. The company have organized a department of publicity, of which Mr. Arthur Warren, who is well known in this field, has been appointed manager. It is the request of this concern that all communications referring to publicity in any form connected with the Allis-Chalmers Company, including the Bullock Electric Manufacturing Company, which they have acquired, will be for the future addressed to The Department of Publicity, Allis-Chalmers Company, Milwaukee, Wis.

The Baldwin Locomotive Works Record of Recent Construction No. 45 shows as a frontispiece the exhibit of that well known firm at the Osaka exposition in Japan. A description of tandem compound locomotives written in English and French is to be found on the opening pages, and a good half tone of the heavy 2-10-2 tandem compound for the Atcheson, Topeka & Santa Fe is shown. The remainder of the catalogue is devoted to half tones of locomotives built for leading roads in this country. The dimensions are given in both English and French equivalents. The half tones are printed upon specially tinted paper and are very clear and good.

The Canadian Westinghouse Company, Limited, of Hamilton, Canada, have recently engaged Mr. C. C. Starr, who was formerly connected with the firm of John Starr, Son & Company, to act as their representative in the Maritime Provinces, with headquarters at 134 Granville street, Halifax, Nova Scotia. The Maritime Provinces are included in the district of the Canadian Westinghouse Company's Montreal office, and Mr. Starr will be consequently an attache of that office.

The Nernst Lamp Company has recently removed its Boston office from 131 State street to 501 Atlantic avenue. The office will as heretofore be in charge of Mr. Geo. C. Ewing, as district manager, and will carry a complete stock of Nernst lamps and supplies, insuring prompt service to customers.

The right faith of man is not intended to give him repose, but to enable him to do his work.—*Ruskin.*

THE NEW BARRETT GEARED RATCHET LEVER JACK

30 Tons Lifting
Capacity.

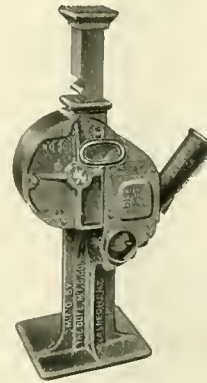

PATENTED.

MADE EXCLUSIVELY BY
The Duff Manufacturing Co.,
Works: Allegheny, Pa. PITTSBURG, PA.

An improved **QUICK-ACTING JACK** for the rapid handling of loaded freight cars, Pullman cars and all heavy loads.

Has the simplicity of an ordinary Lever Jack, the leverage being specially compounded to permit **EASE OF OPERATION** and **QUICK-ACTION**.

No complicated features. Cannot get out of order. Send for Special Bulletin "L" and further information.

TAKE THE

SUNSET LIMITED

Across the Continent

SOUTHERN PACIFIC

TRAVERSES

Louisiana, Texas, New Mexico,
Arizona, California

Observation Sleeping Cars, Dining Cars,
Day Coaches. Chair Cars,
Excursion Sleeping Cars

OIL-BURNING LOCOMOTIVES
No Smoke! No Dirt! No Cinders!

Write to or inquire at any Southern Pacific
Office, as follows:

170 Washington Street, Boston
349 1/2 Broadway, New York City
100 South Third Street, Philadelphia
210 North Charles Street, Baltimore
129 South Franklin Street, Syracuse

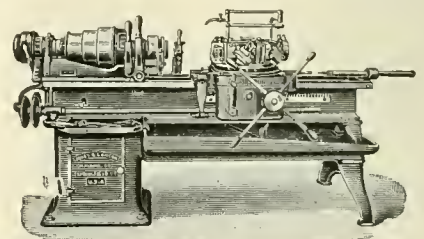

JONES & LAMSON MACHINE CO.

Main Office and Works:
SPRINGFIELD, VERMONT, U. S. A.

A, B, C and Lisber's Code used.

British Office: Jubilee Buildings, 97 Queen Victoria St., London, E. C. France and Spain: Ph. Bonvillain, 6, Rue Blanche, 6, Paris, France. Germany, Belgium, Holland, Switzerland and Austria-Hungary, M. Koyemann Charlottenstrasse 112, Dusseldorf, Germany.

H. S. PETERS' BROTHERHOOD OVERALLS

have gone to almost every part of the World where Overalls are worn and are everywhere conceded to be the BEST. Every point of material, cut, construction and finish is carefully looked after; the only way that superiority can be attained. Every garment is absolutely guaranteed. The Patented, Fleece-lined, Safety Watch Pocket is alone worth a whole suit of any other make.

I'll send sample suits, charges paid, to any place in the World where mail or express goes, where I have no retail agency; sample materials and full particulars for the asking.

UNION MADE
OF COURSE —
B.L.E 3—H.S. PETERS—B.L.E. 171
DOVER, NEW JERSEY, U. S. A.



The Twentieth Century Master Mechanic

Won't use solid Mandrels. Cost too much, take up too much room and don't give satisfaction.

Nicholson Expanding Mandrels

Take everything from 1 to 7 inch holes. Take up little room—always ready and you can buy four sets for the cost of one of the solid kind.

Are You Using Them ?

Catalogue tells you more about them.

W. H. Nicholson & Co.
Wilkesbarre, Pa.

Some Good Things.

The Atlas Machine Company, of 24 Callendar street, Providence, R. I., have placed on the market a very handy little shop device. It is for removing a broken tap from a hole and it is especially valuable when the tap happens to break off below the surface of the piece which is being tapped. To use this tool the end is pushed into the tapped hole, the three fingers of the little "tap extractor" slide forward into the grooves of the tap by means of the outer collar, the sleeve is then slid down close to the work and the tap screwed out by means of a wrench set on the squared outer end of the tool.

Another handy product made by this firm is a toomaker's vise. It is graduated in degrees for horizontal and vertical rotary movements, and can be quickly transformed into a plain vise by removing the base, to which it is attached by two tan bolts. The movable base which revolves on ground cones has a vertical movement of 55 degrees, while the horizontal movement, also on ground cones, can travel the complete circle. The movable jaw is made light to afford the maximum range of opening, the screw which operates it does not revolve, the handle turns a long nut through which the screw works.

An Ancient Locomotive.

An interesting railroad relic, reminiscent of the first days of the steam locomotive, has been discovered in the north of England, says the *Scientific American*. The Liverpool and Manchester Railroad Company, the first public road constructed, it will be remembered, inaugurated a competition in the latter part of the 20's of the past century for a locomotive, in which Stephenson and other inventors participated. Three engines—the "Rocket," by Stephenson; the "Sans Pareil," by Hackworth, and the "Novelty," by Braithwaite and Ericsson, respectively—participated in the trials that were carried out in 1830. As is well known, Stephenson's "Rocket" secured the award of \$2,500, which was offered, as being the most suitable engine attaining a speed of twenty-nine miles per hour. The "Sans Pareil" was second with a speed of twenty-three miles per hour, while the "Novelty" withdrew from the trials owing to the joints of the boiler giving way when the locomotive had traveled only three miles. Both the "Rocket" and the "Sans Pareil" are now preserved in the South Kensington Museum, but the "Novelty" mysteriously disappeared and was never found again until quite recently. It appears that Ericsson was so mortified by the failure of his conception that he left it with his friend Mr. Mell-

ing, who possessed engineering works located upon a space adjoining the Rainhill station. These works were subsequently dismantled and the premises were occupied by the Rainhill Gas and Water Company. The "Novelty" was thus lost sight of, but it has now been recognized working as a stationary engine, the wheels having been removed for this purpose and its identity thus somewhat disguised. Attempts are to be made to secure this third premier locomotive, and to place it alongside of its two contemporaries in the South Kensington Museum.



BROKEN TAP EXTRACTOR.

The Brown & Sharpe Manufacturing Company, of Providence, R. I., have issued their 1904 general catalogue of machinery and tools. The book is bound in blue paper and the pages are 3¼x5½ ins. in size. It has been thoroughly revised and contains 482 pages. The new matter, together with the changes in the old, renders it especially desirable that this should replace former editions. The large number of tables it contains, together with the other general information, makes it valuable to the work-

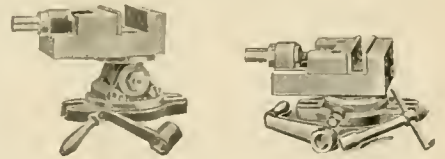

ATLAS TOOL MAKERS' SWIVEL VISE.

man as a book of reference. The principal additions this year to the various lines of machines and tools are given in the colored insert. This catalogue is mailed upon application to any address without charge, may be had by hardware and supply dealers.

The general offices of the Lehigh Valley Railroad Company, now at No. 26 Cortlandt street, New York, have been transferred to No. 143 Liberty street, New York. The transfer includes the executive staff.

One of the most wonderful railroads in the world is that in Peru, Pasco gold fields. It is 78 miles in length, and rises in that distance to an altitude of 15,645 ft. There is not an inch of down grade on the trip up. Between seven and eight thousand persons died or were killed during the construction of the road.

Other People's Ideas.

The other day we had the opportunity of visiting what was called a Motor Boat Exhibition in a large hall on upper Broadway, and later on we saw the Sportsmen's Show at the Madison Square Garden in New York. Now, while we have not the space to describe all the wonderful things which were on view, we would like to remark that the time honored truth was forced home on us, viz.: That no one man knows it all. It is wonderful to see how any one line you like to pick out has been followed up. For example in the motor boat exhibit it was clear to the observer that the reversal of motion of the small pleasure craft, especially those using gasoline engines, was accomplished by the reversal of the propeller blades, and this can be done without stopping the engine. All variations of speed, ahead or astern, can be had in the same way. It was interesting to see this fact demonstrated, but it was even more interesting to see the various ways in which different inventors and manufacturers had accomplished the self same purpose. To see such an exhibition is to get hold of other people's ideas, that is the great point. Everyone cannot visit exhibitions, but nevertheless every live man or woman can get hold of other people's ideas, and may possibly make use of them, or improve upon them. The general way to get hold of other people's ideas is to read. Our subscribers are being constantly put in reach of other people's ideas, on the very subjects which most concern them, and our list of books, given below, furnishes another and an excellent way of getting other people's ideas. Look the list over and judge for yourself.

The first on the list is, of course, RAILWAY AND LOCOMOTIVE ENGINEERING, a practical journal of railway motive power and rolling stock. It costs only \$2.00 a year, and is well worth the money, and besides the paper is a welcome visitor in every household. Let your wife and children see it.

"Locomotive Engine Running and Management," by Angus Sinclair, is an old and a universal favorite. A well-known general manager remarked in a meeting of railroad men lately, "I attribute much of my success in life to the inspiration of that book. It was my pocket companion for years." We sell it for \$2.00.

"Practical Shop Talks," Colvin. This is a very helpful book, combining instruction with amusement. It is a particularly useful book to the young mechanic. It has a stimulating effect in inducing him to study his business. The price of it is 50 cents.

"Examination Questions for Promotion," Thompson. This book is used by many master mechanics and traveling engineers in the examination of firemen

for promotion and of engineers likely to be hired. It contains in small compass a large amount of information about the locomotive. Convenient pocket size. We cordially recommend this book. The price is 75 cents.

"Compound Locomotives." Colvin. This book instructs a man so that he will understand the construction and operation of a compound locomotive as well as he now understands a simple engine. Tells all about running, breakdowns and repairs. Convenient pocket size, bound in leather, \$1.00.

"Catechism of the Steam Plant." Hemmenway. Contains information that will enable a man to take out a license to run a stationary engine. Tells about boilers, heating surface, horse power, condensers, feed water heaters, air pumps, engines, strength of boilers, testing boiler performances, etc., etc. This is only a partial list of its contents. It is in the question and answer style. 128 pages. Pocket size. 50 cents.

"Care and Management of Locomotive Boilers." Raps. This is a book that ought to be in the hands of every person who is in any way interested in keeping boilers in safe working order. Written by a foreman boilermaker. Also contains several chapters on oil burning locomotives. Price, 50 cents.

"Locomotive Link Motion." Halsey. Any person who gives a little study to this book ceases to find link motion a puzzle. Explains about valves and valve motion in plain language, easily understood. Price, \$1.00.

"Machine Shop Arithmetic." Colvin and Cheney. This is a book that no person engaged in mechanical occupations can afford to do without. Enables any workman to figure out all the shop and machine problems which are so puzzling for want of a little knowledge. We sell it for 50 cents.

"Firing Locomotives." Sinclair. Treats in an easy way the principles of combustion. While treating on the chemistry of heat and combustion it is easily understood by every intelligent fireman. The price is 50 cents.

"Skeevers' Object Lessons." Hill. A collection of the famous object lesson stories which appeared in this paper several years ago. They are interesting, laughable and best of all they are of practical value to-day. \$1.00.

"Stories of the Railroad." Hill. Best railroad stories ever written. Those who have not read these stories have missed a great literary treat. \$1.50.

"Standard Train Rules." This is the code of Train Rules prepared by the American Railway Association, for the operating of all trains on single or double track. Used by nearly all railroads. Study of this book would prevent many collisions. Price, 50 cents.

"Mechanical Engineers' Pocket Book." Kent. This book contains 1,100 pages

Besides **ASHTON LOCOMOTIVE STEAM GAGES**



WE MAKE

Duplex Air Gages
Gage Testers
Blow-off Valves
Chime Steam Whistles
Pop Valves

ALL OF A SUPERIOR QUALITY

Catalogue *Lo*n Application

The Ashton Valve Company, 271 Franklin Street, Boston, Mass.

American Locomotive Sander Company

13th & Willow Sts., Philadelphia, Pa.

Proprietors and Manufacturers,

LEACH, SHERBURNE, DEAN, HOUSTON, "SHE" and CURTIS SANDERS

"SLIGO" IRON

The Standard for Eighty Years

for

DUCTILITY and TOUGHNESS

Staybolts

Unexcelled for **Piston Rods**

Crank Pins

AND DIFFICULT FORGINGS

SLIGO IRON & STEEL CO.

Successor to Phillips, Nimick & Co.

PITTSBURGH, PA.

The Union Switch & Signal Co.

Consulting and Manufacturing Signal Engineers.

GENERAL OFFICES AND WORKS AT SWISSVALE, PA.

DISTRICT OFFICES:

New York: Central Building, 143 Liberty Street.

Chicago: 1536 Monadnock Building.
St. Louis: Terminal Station.

IF YOU ARE A

BOILER MAKER

OR

SHEET IRON WORKER

and are interested in laying out work, send for my sample blue print.

It contains 20 practical problems in sheet metal work, and fully explains my practical method of teaching the subject. Sent upon receipt of 6c. in stamps.

EDWARD BRADY, Room 217, 38 Park Row, N.Y.C

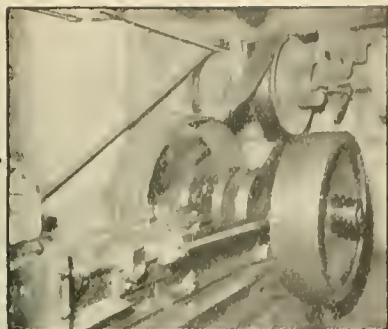

PERFECT BELTS

All belts can be run easy with *Cling-Surface*, do fullest work and not slip. It is a preservative filler for belts, not a surface dressing and not sticky.

This belt (Peninsular Tool Co., Detroit) is doing 35 H.P., 180 R P.M. on 8 ft. centers and is 15 in. slack. Does it easily.

Order on trial, test. Pay only if satisfactory.

CLING-SURFACE MFG CO
124-130 Virginia Street
BUFFALO NY

6x3/4 inches of closely printed minion type, containing mechanical engineering matter. It ought to be in the bookcase of every engineer who takes an interest in engineering questions. We use it constantly as a reference for questions sent to us to be answered. Full of tables and illustrations. Morocco leather, \$5.00.

"Locomotives, Simple, Compound and Electric." Reagan. An excellent book for people interested in any kind of locomotive. It will be found particularly useful to men handling or repairing compound locomotives. It is the real locomotive up to date. \$2.50.

RAILWAY AND LOCOMOTIVE ENGINEERING. Bound volumes. \$3.00.

The Kennicott Water Softener Company will, after April 15, occupy their new offices, 525-527-529 Railway Exchange Building, corner Jackson and Michigan Boulevards, Chicago, where they will be pleased to see their friends.

Very Slack, but Very Good.

Here is an interesting example of the possibility of belt management from the use of *Cling-Surface*, made by the *Cling-*



SLACK BELT KEEPING BUSY.

Surface Company, 124-130 Virginia street, Buffalo, N. Y. It shows the main belt in the boiler shop of one of our leading railroad shops. The belt is 12 ins. double leather and is between a 6 ft. 8 ins. driving pulley to a 30 in. driven pulley. The driver makes 83 revolutions per minute. Both are iron pulleys.

Before *Cling-Surface* was used, this belt had, of course, to be run tight, with the extra friction load, extra journal friction and general wear which tight belts are compelled to operate under. By eliminating slipping with *Cling-Surface* what is shown in the illustration has become possible with relief of all stresses but that of working load alone and an increase of belt contact to 5/6 of the driving pulley.

This brings up the subject of friction load which absorbs such a large per-

**Handy Folding
PILOT COUPLER**



A safe and neat construction for front ends of road locomotives

Handy Car Equipment Co.
Old Colony Building
Chicago

Flexible Spout

Vertically in straight line. Also laterally. The latest Improvement to

**Poage Water
Columns**

American Valve and Meter Company
CINCINNATI, OHIO.

SEND FOR CATALOGUE

THE DROP SEAT IN POSITION.

Shipped Locomotive Builders several large consignments last year. Ask for our seats when your company is ordering new engines. The Mexican Central Ry. Co. is putting our drop seat No. 7 on all their new engines. We make 20 different styles of Locomotive Cab Seats, \$2 up. Send for new Catalog D containing 100 illustrations and full particulars, free. Send 10c. for Complete Camper's Manual; or, How to Camp Out and What to Do, a practical book of 130 pages, worth \$1.

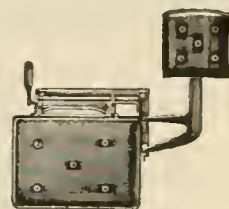

STANNARD & WHITE CO., Racine Jct., Wis.

THE ROBERT W. HUNT & CO.
Bureau of Inspection, Tests and Consultation,
1137 THE ROOKERY, CHICAGO.
66 Broadway, New York. Park Building, Pittsburgh.
31 Norfolk House, London, Eng.

Inspection of Steel Rails, Splice Bars, Railroad Cars, Wheels, Axles, etc. CHEMICAL LABORATORY—Analysis of Ores, Iron, Steel, Oils, Water, etc. PHYSICAL LABORATORY—Test of Metals, Drop and Pulling Test of Connectors, Draw Bars, etc.
Efficiency Tests of Boilers, Engines and Locomotives.

JUST PUBLISHED
—THE—

LOCOMOTIVE UP TO DATE

The greatest accumulation of new and practical matter ever published treating upon the construction and management of modern locomotives, both

SIMPLE and COMPOUND

By CHAS. McSHANE

Author of "One Thousand Pointers for Machinists and Engineers."

Special Exhaustive Articles were prepared for this new book by the

- Baldwin Locomotive Works
- Rogers Locomotive Company
- Schenectady Locomotive Works
- Pittsburg Loco. and Car Works
- Brooks Locomotive Works
- Dickson Locomotive Works
- Cooke Loco. and Machine Co.
- Richmond Loco. and Machine Co.

With contributions from more than one hundred prominent railway officials and inventors of special railway appliances.

736 Pages, 6x9 Inches 380 Illustrations
An Absolute Authority on All Subjects relating to the Locomotive

Bound in Fine Cloth, \$2.50

ONE THOUSAND POINTERS

—FOR—
MACHINISTS and ENGINEERS

By CHAS. McSHANE

(Practical Machinist)

Assisted by CLINTON B. CONGER, Air Brake Expert; J. P. HINE, Mem. Div. 37, B. of L. E.; J. G. A. MEYER, Mechanical Engineer; W. M. F. GOSS, Mechanical Engineer; JNO. C. WHITE, Indicator Expert. The only complete work on the locomotive combining both theory and practice. 342 pages, 187 illustrations.

BOUND IN FINE CLOTH, \$1.50

The only book ever indorsed by the International Association of Machinists. Agents wanted everywhere; write for terms, commissions and club rates. Will be sent prepaid to any address upon receipt of price.

GRIFFIN & WINTERS, Pub.

171 La Salle St., CHICAGO, ILL., U. S. A.

Patents.

GEO. P. WHITTLESEY,

McGILL BUILDING,

WASHINGTON, D. C.

Terms Reasonable. Pamphlet Sent

Ball's Official R. R. Standard Watches

16 AND 18 SIZE.



17 AND 21 RUBY JEWELS, SAPPHIRE PALLETS

BALL'S IMPROVED SAFETY DOUBLE ROLLER

Are without question the finest watches that American talent and skilled labor can produce, and they are giving such universal satisfaction that we have no hesitancy in claiming that they are the best and safest railroad watch on the market.

Tests severe and numerous have proven this fact to the most critical users in all sections of the country, to which thousands of good Railroad and Brotherhood men are ready to certify.

We have an authorized agent in nearly every railroad center. Call on him for information and facts. Write us for descriptive matter.

The Webb C. Ball Watch Co.

Watch Manufacturers

Ball Building, Cleveland, Ohio, U. S. A.

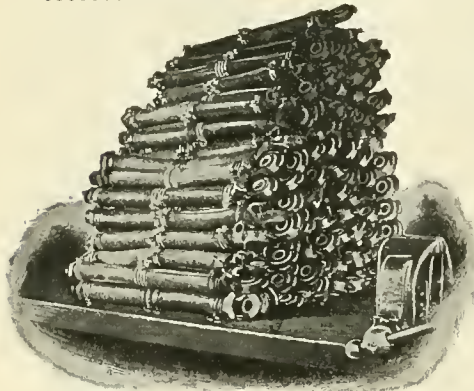

FINISHED WORK

Above cut shows finished work of

HOSE REPAIR OUTFIT

This outfit will do anything in the way of repairing Steam, Signal or Air Brake Hose, strip, cut, splice and fit up. Also fits up new hose.

Will pay for itself on most any railroad in a year and many times over on some roads.

Shall we tell you more about it?

BUKER & CARR MFG. Co.

Office, Fairview Heights, No. 19 ROCHESTER, N. Y., U. S. A.

centage of the power generated for a shop and in which tight belts are one of the greatest elements of loss. Slack belts, or if not practicable to be slack, then easy belts mean a very important economy.

The Nernst Lamp Company has recently established district offices at St. Louis, Mo., and Denver, Col. The St. Louis office, embracing the southwest territory, is located at 908 Pine street, with Mr. H. M. Reed as District Sales Manager. The Denver office, covering the middle western territory, is located at 1619 Glenarm street, with Mr. R. D. Marthens as District Sales Manager. These offices carry a complete stock of Nernst Lamps and supplies, and are provided with attractive exhibition rooms, in which will be shown the different types of Nernst Lamps in actual operation and in comparative tests with other illuminants.

The first lodge of the Brotherhood of Locomotive Engineers, organized on the Chicago, Burlington & Quincy since 1883, was established a few weeks ago at Galesburg, Ill. Other B. of L. E. lodges will be organized at various points along the line.

Razorback Hog in Rhyme.

A North Missouri farmer whose hog was killed by a train wrote the company's claim agent for a settlement. He penned his communication thus:

My razorback strolled down your track
A week ago to-day.
Your Twenty-nine came down the line
And snuffed his light away.
You can't blame me—the hog, you see,
Slipped through a cattle gate.
So kindly pen a check for ten,
This debt to liquidate.

A few days later he received the following:

Dear Sir:
Old Twenty-nine came down the line
And killed your hog, we know,
But razorbacks on railroad tracks
Quite often meet with woe.
Therefore my friend, we cannot send
The check for which you pine.
Just plant the dead; place o'er his head:
"Here lies a foolish swine."

—Kansas City Star.

Flat—Not Flattering.

"Dear me," said the young bride, in the sleeper, "these berths are awfully crowded. Can't we get a flat, dear?"
"Who ever heard of a flat on a train?" chuckled her big husband.
"Why, you goose, I've often heard of flat cars."—Chicago News.

The McCORD BOX KEEPS OUT THE DUST.



SEE HOW THE LID FITS.

McCord & Company,

CHICAGO

NEW YORK

CONTENTS.

	PAGE.
Accidents, Comparison of, in two countries.....	213
Mileage Basis for Comparing Railway.....	209
Railroads Liable for, Resulting from	
Faulty Attachments.....	214
Air Brake Department.....	217
Association, Air Brake.....	217
*Brake, Troubles with Straight Air.....	237
Brakes, Better Method of Stenciling.....	218
Convention, Air Brake.....	217
*Machine, Triple Piston Ring Grindlog.....	217
Patents, Air Brake.....	236
Stenciling, Better Method of, Brakes.....	218
Valve, New York Compensating.....	218
Appliance, *Compressed Air, for Unloading	
Rails.....	233
*For Moving Teuders.....	232
*Handy Shop.....	198
*Lathe.....	233
*Used in Shutting Bottom Door of Cupola.....	216
Apprentice, Railway Shop.....	212
Boilers, *Designing of Locomotive, by Roger	
Atkinson.....	200
Brakes, Power, Needed for Street Cars.....	228
Car, Fairness in, Interchange.....	222
Cars, Bad Order.....	198
Power Brakes Needed for Street.....	228
Correspondence, General.....	205
Cylinders, Lubrication of Valves and.....	213
Firing, Good and Bad.....	207
"Hammer Blow," Want Government Money	
to Ventilate.....	214
Influence of Brain Power on Dividends.....	231
Invention, Venetian Railway Signaling.....	235
Locomotive, An Ancient.....	241
Slipping Shut Off of.....	206, 208
*Locomotive, Baldwin 2-8-0 for Japanese	
Government.....	227
Baldwin 4-6-0 for the Erie.....	231
British Gasoline.....	234
English Three Cylinder Compound, on	
Midland Ry.....	221
Growth of the, by Angus Sinclair.....	202
Michigan Central 4-4-2.....	199
New York Central 4-6-2.....	211
Lubrication, The, of Valves and Cylinders.....	213
Machinery, Railway, at St. Louis Exposition	
.....	231
*Notes, Brotherhood Convention.....	205
Observation, Intelligent, Properly Applied.....	232
Packing, Leaky Rod.....	213
Pensions, for War Time Locomotive Engi-	
neers.....	213
Personals.....	229
Questions Answered.....	215
Railway Man, Making A.....	214
Signaling, Venetian Railway, Invention.....	235
*Signals and Signaling, by George S. Hodg-	
ins.....	224
Steel Rules, How Made.....	226
Stories and Narratives:	
Steel vs. Iron, by George H. Richards.....	234
Ramble on Western Railroads.....	227
Tests for Water.....	238
Train Orders.....	214
Transportation, J. J. Hill on Low Cost of	
Freight.....	215
Unexpected, The.....	197
Valves, Lubrication of, and Cylinders.....	213
Piston.....	208
Water, Tests for.....	238
Wheel, Cause of, Distortion in Photograph.....	207
Winans, Correction of "The Work of Ross".....	208

Railway and Locomotive Engineering

Copyright by Angus Sinclair Co.—1904

A Practical Journal of Railway Motive Power and Rolling Stock

Vol. XVII.

174 Broadway, New York, June, 1904

No. 6

Pennsylvania Railroad Company's De Glehn Compound.

The French Compound locomotive, illustrated on next page, is of a type very largely used for express service on the French roads, and was designed jointly by the engineers of the Northern Railway of France and Mr. Alfred G. De Glehn, managing director of the Societe Alsacienne de Construction Mecaniques. Various modifications have been introduced during the last fifteen years, and since 1900 the most powerful of these locomotives have been of the "Atlantic" type, but all having the same cylinder arrangement, namely, two high pressure cylinders on the outside, transmitting the power to the back driving wheels, and two inside cylinders, operating on the forward crank axle. The locomotive imported by the Pennsylvania Railroad Company is of a type used on the Paris-Orleans road and is somewhat larger than the locomotives used by the Northern Railway of France, built by the famous company known as the Societe Alsacienne de Construction Mecaniques.

The locomotive in question is of the "Atlantic" type, weighing 161,000 pounds, of which 87,000 pounds are on the driving wheels, which are 80½ in.

tween the frames and a comparatively small number of serve ribbed tubes, in this respect differing materially from the American practice, where from 300 to 390

tubes are used. In this French locomotive there are but 139 tubes. Each cylinder has its own valve motion, all the gears being of the Walshert type; the reversing being done by a screw and wheel in the cab. The reversing gears are so arranged that the high pressure and low pressure cut-offs can be independently controlled. It is claimed by the designers that by this method of independent control, the range of economical performance of the locomotive is very materially increased. Many of the details of the locomotive differ materially from those of the American type, but it is hoped that from the experiences derived from this locomotive much that may be valuable to our practice will be learned.

It was largely from an educational point of view that the importation was made, by the Pennsylvania Railroad Company. The locomotive was constructed by the Societe Alsacienne de Construction Mecaniques,



Courtesy of the Booklovers Magazine. (Stereograph photograph, copyright, 1904, by Underwood & Underwood.)
A TRANS SIBERIAN PASSENGER TRAIN TRANSPORTING NON-COMBATANT MANCHURIAN REFUGEES FROM THE SCENE OF HOSTILITIES.

diameter. The boiler, as is usual in foreign practice, has a copper fire box be-

lief. The boiler, as is usual in foreign practice, has a copper fire box be-

at Belfort, France, and no changes were made upon it other than the minor ones necessary to conform to our American regulations, such as the addition of whistle, bell, headlight, pilot, etc.

Over 1,500 of this general type of locomotives are running on the roads of France, in addition to which a number are used in Germany, Switzerland and some other countries. The Great Western Railway of England has also imported one of these locomotives and is testing it on its road in comparison with the standard locomotive of that railway. The locomotive imported by the Pennsylvania Railroad is supposed to be rather less powerful than the largest of our American passenger locomotives, and should show the best advantage on long distance through trains. It will

Cuban Central Railroad, which controls a line running from Matanzas to Santiago de Cuba, covering almost the entire length of the island and penetrating the wildest portions. With the United Railways, the system extends from Havana to Santiago, a distance of about 600 miles. The two former roads are controlled and operated by English capital, with a small sprinkling of Spanish and Cuban capital. The Cuban Central was built by Sir William C. Van Horn, president of the board of the Canadian Pacific, and it is said that English capital controls it, but I have been informed that the late William C. Whitney, of New York, personally held one-third of the capital stock.

"The road has been in operation for about one year and has already proved to be an exceptionally strong investment. It

"In all the yards of the railroads the 'ponies' which move the cars about the yards, and make up the trains, are unknown, and ox teams are utilized for the work. It is a common sight to see twelve or fourteen oxen yoked to a cut of cars and pulling it about the tracks. In the Villanueva station of the United Railways, the main Havana station of the line, a Cuban in native costume, sombrero and great spurs, mounted on a broncho, precedes every train which leaves the station and waves a big dinner bell in the air to warn the citizens from the tracks. The outrider precedes the train to the city limits, a distance of nearly five miles, continually ringing the bell and assisting the clang of the bell on the engine to frighten the people from the tracks.

"The railways of Cuba undoubtedly possess a great future, for they are continually opening up a country unsurpassed in natural wealth by any country in the world. The rich farming country with which they are gradually colonizing, is said to possess a soil thirty feet in depth and to be unbounded in its productiveness. As many crops of cane as can be harvested are grown on the same ground in a year.

"As the roads are managed at present, American blood is placed in the operating offices. The Cubans are not progressive enough to permit the improvements which are absolutely necessary to the modernizing of the railroad systems. They must be educated to the point where efficient service and modern equipment will be demanded. The roads must be ballasted, they must have heavier and better steel rails and must be provided with better and more convenient cars for the transportation of the passengers. The motive power is principally home made, although I think I saw one antiquated Brooks locomotive which at some remote period had undoubtedly drawn passenger trains in the United States. The average speed of the trains is from twenty to twenty-two miles and a speed of thirty miles is scarcely ever heard of."

Springfield, O.

Cost of Moving Freight.

Ex-Governor Thomas Waller of Connecticut, in a speech made on the occasion of the launching at New London of the big steamer "Dakota" recently built for James J. Hill, remarked:

"In that corner of the vast British Empire—on which the sun never sets—known as the United Kingdom, to carry ten tons of freight ten miles costs the subjects of his Majesty Edward VII \$4.16. In the dominions of the Kaiser the cost is \$3.14. Under the tricolor flag of our sister republic, through the smiling fields of France, the cost is \$2.76. Under our own starry banner,

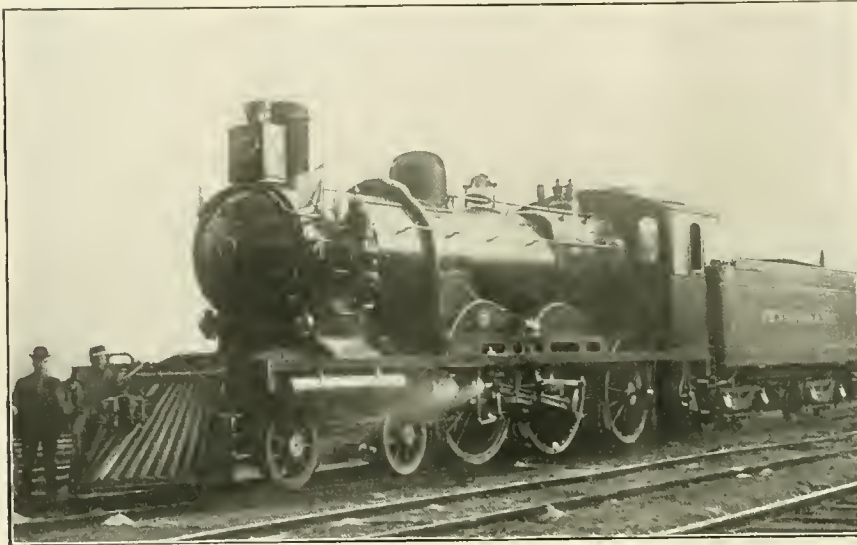

PENNSYLVANIA RAILROAD DE GLEHN COMPOUND.

be tested until in thoroughly good condition, and then sent to the exhibit of the Pennsylvania Railroad system at the Louisiana Purchase Exposition, St. Louis, Mo.

The Railroads of Cuba.

BY H. E. RICE.

Mr. D. Jay Collver, who is connected prominently with the passenger department of the Big Four Railroad, has returned from Cuba, where he made a thorough study of the railroad conditions on the island. He has been making trips to the island for several years past and has become conversant with the operation and management of the railroad systems there. In speaking of the Cuban railroad, he said:

"The railroad system of Cuba is composed of three distinct companies: the United Railways of Havana, with a line and branches 200 miles in length; the Western Railways of Havana, with lines a little less than 200 miles, and the

passes through the richest lumber country of the island. The roadbed on the two older systems is composed of light iron rails and 50 lb. steel rails, but I understand on the new Cuban Central heavier rails of American manufacture have been introduced. Practically all of the equipment used on the island is manufactured in the shops of the companies there or by native industries. The cars are small and of rude construction, being divided by the passenger department into two classes, first and third class. The second class was eliminated some time ago. The first class coaches are patterned after our coaches, but are very inferior specimens of car building. The third class cars are furnished with board seats, and decorations in keeping. A few parlor cars and sleepers are in use between Havana and Santiago, but the style cannot be compared to the style of our modern parlor cars. The trip from Havana to Santiago consumes twenty-four hours.

Heaven bless it! on the lines of our noble host, to carry ten tons of freight ten miles costs only 78 cents, and that, Mr. Chairman, is the reason why the prosperity of our beloved land makes the prosperity of any and every other land beneath the blue canopy seem"—here the orator raised his hands above his head and swept them forward and down in a bow of magnificent tribute to President Hill—"like thirty cents."

Rogers Mogul for the Cotton Belt.

On behalf of the St. Louis Southwestern Railway, often called the Cotton Belt, Mr. T. E. Adams, general master mechanic of the road, recently received some 2-6-0 passenger engines from the Rogers Locomotive Works, of Paterson, N. J.

Balanced slide valves are used. The cylinders are 19x26 ins. and the driving

64½ ins. inside diameter at the smoke box end, but is 71¾ ins. diameter in the waist, the gusset sheet being the second course. The flues are 270 in number, 12 ft. ¾ ins. long, and give a heating surface of 1,735.20 sq. ft. The fire box has a grate area of 28.95 sq. ft. and the fire box heating surface is 162.37, thus giving a total of 1,897.66 sq. ft. The roof and crown sheets are level and there is a steam and water space between them of about 24 ins. The back sheet is straight up and down, and the water legs are 4 in. wide all around.

The tender has a 10-in. steel channel frame. The tank capacity is 5,500 gallons of water and 12 tons of coal. The whole machine, engine and tender weighs 145,000 lbs. It is a good example of workmanship and design of this type of engine and it is part of the Rogers exhibit at the Louisiana Purchase Expo-

6,080 ft. That is, just 800 ft. longer than the mile with which we railroad men are familiar. This nautical mile, often called a naut, is the one-sixtieth part of one degree measured along the earth's surface at the equator. The term knot, in this connection, is used to mean so many sea miles per hour. When a ship is called a 16-knot ship, it means that her speed is, or ought to be, 16 nautical miles per hour. The "per hour" idea is included in the term "knot." A sea mile, or a geographical mile, or a nautical mile, which are all the same, can't any of them be a knot. It is, therefore, incorrect to say that a vessel steamed so many knots per hour, because that is equivalent to saying she steamed so many sea miles per hour, per hour. This expression introduces the idea of acceleration. It there-

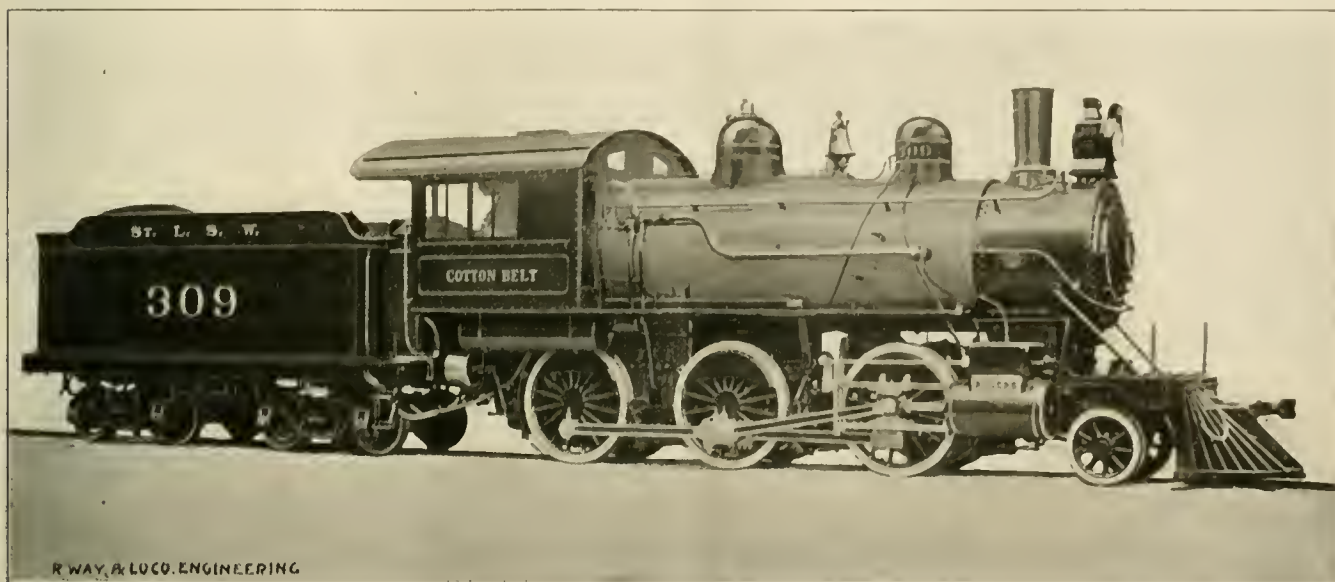

Thomas E. Adams, General Master Mechanic.

Rogers Locomotive Works, Builders.

ROGERS PASSENGER MOGUL FOR THE COTTON BELT.

wheels are 61 ins. in diameter. The adhesive weight is 127,000 lbs. and with 200 lbs. steam pressure the calculated tractive effort is about 26,100 lbs. and the ratio of tractive effort to adhesive weight is as 1 to 4.86.

The driving wheels are equally spaced, which fact, although not important, gives the engine a very symmetrical appearance. All the wheels are flanged and the springs of the main and rear drivers are underhung, and are equalized together. The pony truck and the leading drivers are equalized together. The frame bracing is very substantial. The Rogers Works' general practice is to bolt a heavy and broad flanged steel casting between the frames, just back of the cylinder saddle.

The boiler is of the extension wagon top semi-wide fire box kind intended for bituminous coal. The barrel measures

sition. A few of the principal dimensions are appended for reference:

Driving Wheels—Diam., 61 ins.; journals, 9x12 ins.; wheel base, 14 ft. 8 ins.; total wheel base of engine, 22 ft. 9 ins.; weight on drivers, 127,000 lbs.; truck, 18,000 lbs.; total—engine, 145,000 lbs.

Boiler—Working pressure, 200 lbs.; thickness of barrel, 1½ in.; thickness of dome course, ¾ in.

Fire Box—Thickness crown, 5/16 in.; flue sheet, 1/8 in.; sides and back, 3/8 in.

Grate—Length, 106 ins.; width, 39 ins.; safety valves, two, 3 ins.; lubricator, No. 9, triple sight feed; headlight, 18 ins. round case; boiler covering, sectional, magnesia.

Concerning the Word Knot.

A very interesting bit of information about the word knot, when used concerning the speed of a ship, is given by Mr. Andrew Jamieson in a recent issue of *The Engineer*. He tells us that, according to the British admiralty regulations, one nautical or sea mile is

fore appears that one naut is 6,080 ft., and one knot is 6,080 ft. per hour.

The following notice from Mr. George L. Barton, general manager, of the company referred to, will be read with interest, viz.: The Suffolk & Carolina Railway Company begs to announce the approaching completion of its extension to Elizabeth City, N. C. Coincidentally with the opening to traffic of this extension will occur the change of gauge from 42 ins. to standard of its present track from Suffolk to Edenton. On and after the 20th inst. this company will therefore be prepared to offer the shortest and quickest route for either passengers or freight via Suffolk, Va., to southern and western points from Elizabeth City, Edenton and intermediate stations.

Old Wooden Rockersill Car.

We present an illustration of an old time car, which, more than a half a century ago, carried passengers between Bordentown and South Amboy. In those days, passengers for New York were taken on a steamboat to Bordentown, from which point the railroad ran to South Amboy, and from thence the journey was made

with gold leaf. No head lining was used, but a small bracket gilded at the eaves connecting side pillows of carlines. The car was equipped with six wheel trucks, with 30 in. wheels, made of red cedar blocks, with tires of either iron or steel, shrunk on. When the car was finished a number of railroad officials visited the shops and each praised the car for its finish and for the

"I did," said Mr. Hill.

"Well, your statement is incorrect," declared the young fellow. "I have been hustling for a job for the past six months, and can't get work at any thing I can do."

"Well, that's just it," observed Mr. Hill. "What can you do?"

"I have had several years' experience as a stenographer, am an expert book-keeper, have been a shipping clerk and know the business; am an Advertiser man," said the young man, all in one breath.

Mr. Hill summoned his secretary and dictated a letter to his lieutenants in the Great Northern offices in St. Paul. He intended to try the young man and find out what was in him.

"Thank you, Mr. Hill," he said, as he turned away, but in a moment he was back again, and broke out—

"Say, Mr. Hill, do I take the brake beam to St. Paul?"

Mr. Hill turned to his secretary and said: "Tom, write this man out a pass, account, employee." I. C. D.

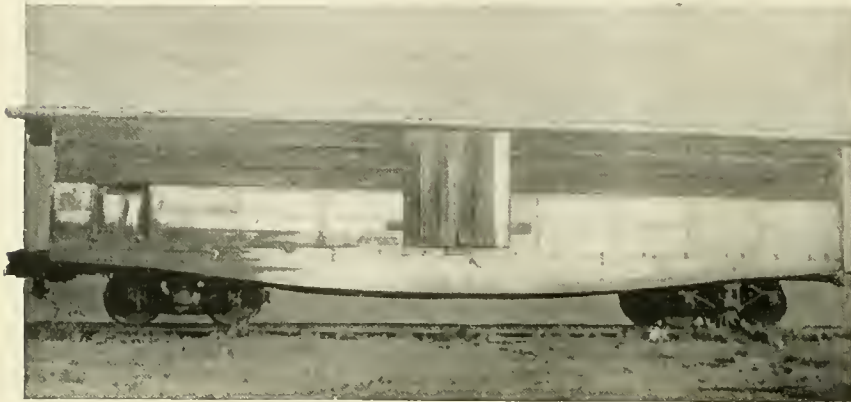

OLD STYLE ROCKERSILL CAR.

by ferry to New York. The old coach had a door in either side, as well as at the ends. Passengers passed through these doorways, as the station platforms were built on a level with the car floors. The end doors were used in passing from one car to another.

This type of car was called "rockersill," on account of the shape of the sills, which resemble the base of a rocking chair. This form of design has the merit of being very strong, and is stiff enough to dispense with truss rods. In looking at this railroad relic it is interesting to notice the rockersill idea appearing again in modern design. One of our staff recently took a snapshot of P. & R. box car, 14018, which shows a pressed steel side sill. This sill is very curiously like, in outline, to the wooden sill used fifty years ago.

Mr. W. Haffelfinger, of Bordentown, N. J., in speaking to RAILWAY AND LOCOMOTIVE ENGINEERING of this old passenger car, said:

The first rockersill car was built from the plans furnished by Edwin A. Stevens, in 1848, at the Camden-Amboy Railroad shops, near Bordentown, Edwin Lockwood being the master car builder. This car was built so as to secure the safety of passengers as the rockersills were very strong, much stronger than the brace sills formerly used. The sills extended to about 12 ins. from the rail. In case of trucks or journals breaking, the car would slide on the roadbed. It was the first car trimmed with red plush and the coves on the side pillows and carlines were gilded

comfort it would give to passengers. We continued to build the rockersill cars up to 1864 or '65. Most of the rockersill cars built before 1859 were brought to the shops and remodeled, having a raised roof put on, side doors in center of car closed up, hoods put on ends of cars and lengthened out platforms, equipped with steps. These cars were in service on branch roads and local trains when the Pennsylvania Railroad leased the United Roads of N. J.

The interesting fact is stated that so indestructible by wear or decay is the African teak wood that vessels built of it have lasted one hundred years, to be then only broken up because of their poor sailing qualities from faulty models. The wood, in fact, is one of the most remarkable known, on account of its very great weight, hardness and durability, its weight varying from forty-two to fifty-two pounds per cubic foot. It works easily, but, on account of the large quantity of silex



MODERN BOX CAR WITH PRESSED STEEL SIDE SILL APPROXIMATING TO ROCKERSILL SHAPE.

A Gentle Hint.

The following story about Mr. James J. Hill, president of the Great Northern Railway Line, is told in the Northwest. Mr. Hill was talking to some friends in a hotel lobby when a young man hustled up to him and said:

"Mr. Hill, a year ago you claimed that no one need be out of a job in this part of the country."

contained in it, the tools employed are quickly worn away. It also contains oil, which prevents spikes and other iron work, with which it comes in contact, from rusting.

No work is worth doing badly, and he who puts his best into every task will outstrip the man who waits for a great opportunity.—Joseph Chamberlain.

The British North Borneo Railway.

With all the popular attention at present directed to Eastern Asia, few of our readers know anything about Borneo. To most people it is merely a name, yet it is the second largest island in the world, and is about three and a half times larger than the island of Great Britain.

Through the courtesy of the editor of the *Railway Magazine*, of London, we received photographs of a variety of railway scenes in Borneo, from which the engravings were made, presented to our readers on the opposite page. Borneo is an island in the Malay Archipelago, south of China, and possesses

British North Borneo Company acquired 31,000 square miles of land that is rich in a great variety of fine timber, minerals, gutta percha, india rubber, ivory, sago, pepper, tortoise shell and other products too numerous to mention, among them being coal, iron, manganese, mineral oils and gold.

Until the British North Borneo Company entered the territory, the principal modes of transportation were the backs of men, ponies and bullocks. In order to develop their property, the British North Borneo Company began building a railway about eight years ago, and now they have over one hundred miles in operation through a country whose

commissioner of lands, and quoted by the *Railway Magazine*. He says: "In 1895, I made a foot path 33 miles long, and the natives assisted me, and I paid them in cloth—a fathom of red or black cloth to each man, woman and child, at the end of each day's work. When they had stored up more cloth than they could use, they requested money, and I paid their wages in bronze cents, one hundred to the dollar, and later they took their pay monthly in dollar notes, with which they bought goods at the shops established by traders, who gladly took advantage of the new road to push their trade into the interior. . . . The trader paid no money—



WORKMAN'S TRAIN CROSSING TEMPORARY TRESTLE.



RAILWAY BRIDGE IN NORTH BORNEO, WITH BALLAST TRAIN CROSSING.



THROUGH THE JUNGLE IN NORTH BORNEO.



SCENE ON A NORTH BORNEO RAILWAY.

the natural resources that might make it one of the richest countries in the world, but it has only about 200,000 population composed of oriental races that enjoy a long inherited prejudice against working. Nature feeds them with food that has merely to be gathered, and the climate demands no protection in the form of clothing, so the greater part of them live happy in a real state of nature.

When a land like that is overflowing with ungathered riches, some enterprising people generally step in and help to save the good things from going to waste. In the case of Borneo the

character can be judged from our pictures.

The British North Borneo Company appear to have acquired the rights of government along with the land, for they have formulated laws which must be a little galling to the tribes, whose principal diversion before the railway came was head hunting. That pastime has been abolished, and many of the natives have been induced to turn their attention to farming and to working on the railway.

The methods employed to convert savages into domestic beings, may be understood from a report made by a

money was unknown in the interior up to 1895, all trade being carried on by barter."

The British North Borneo Company appear to operate their railway on cheap lines, the highest paid employees being engine drivers, who receive \$75 a month. Guards and station masters are paid \$20 per month.

The most surprising thing about the company is that they are permitted to make laws regulating the relations between the natives and the railway. The practice of inflicting fines, so dear to the hearts of British railway officials, is in conspicuous force in North Borneo.

They enforce one rule that might be imitated by American railroad managers to the comfort of patrons. Tickets are sold to passengers subject to the condition of their being sitting room in the carriages. In the event of passengers having purchased tickets before it has been ascertained that the train is full, those who have obtained tickets for the longest distance are accommodated first, those who are only going short journeys being required to wait their turn. Another rule is that

Resident Engineer for Railways; they are then sold by public auction in order that the sum due may be realized, should the person to whom the goods are consigned decline to pay the amount due after receiving notice. The rules upon the subject of infectious diseases are very stringent; any passenger who is suffering from smallpox, or any other infectious disease, is liable to a fine of two hundred and fifty dollars, besides being required to pay the expenses incurred in disinfecting

ble to many years' imprisonment. The British North Borneo Company evidently hold valuable public franchises, and the officials know how to make the best of them.

Non-Political Management of State-Owned Railways.

Speaking to a representative of the Melbourne (Australia) *Age*, Mr. Shiels, the former minister of railways in the Island continent, said, in effect, concerning the new railway commission, Mr. Thomas Tait and his colleagues are the best board of managers that the Victorian railways ever had. The work accomplished by them and their plans for the future are such that it is clear that they are giving to the taxpayers the best money results ever achieved in the department.

The creation of this commission by the Government of Australia was for the purpose of putting the administration of the state-owned railroads beyond and above political and party influence. Mr. Thomas Tait, the chief commissioner, will be remembered on this side of the world as having been for a number of years manager of transportation on the Canadian Pacific Railway. Want of method, laxity and very slipshod supervision have given way under the commission, to system, order, businesslike discipline in the administration of the finance department and the pace has been set for all other departments.

The working expenses have been re-



WORK TRAIN IN BRITISH NORTH BORNEO.

preference is given according to the order in which the tickets have been issued, and that like order is observed with regard to goods. As to the penalty for fraud, in the shape of traveling in a carriage of a higher class than that for which the fare has been paid, or by continuing the journey beyond the station for which the passenger's ticket was intended, the punishment is a fine which may amount to twenty dollars. Quitting a carriage while the train is in motion is a practice which is sternly discouraged by the authorities by means of fines of ten dollars or less. Nor are native passengers encouraged to smoke, chew betel nut, smoke opium, or in other ways make themselves unpleasant to their European neighbors, the punishment for such offenses being a ten dollar fine. Should a passenger insist upon repeating the offense after being warned to desist, he may be removed from the station premises, and be required to forfeit the amount paid for his fare.

The officials endeavor to put down drunkenness on the part of native passengers, the punishment being a fine or imprisonment—with or without hard labor—for a term not exceeding three months. For this offense forfeiture of the ticket is also incurred, a thing which causes considerable annoyance to the colored passenger. Nor are male native passengers allowed (without lawful excuse) to enter a carriage which has been set apart for the use of women, a fine of as large a sum as fifty dollars being extracted from those who offend in this manner.

Should a person fail to pay money due for conveyance of goods he is liable to have his packages seized by the

the carriage occupied by him while so traveling. It has also been found necessary to severely punish those natives who insist upon driving their cattle and other animals across the railway. If the native permits his cattle to stray upon the railway he is liable to a fine of five dollars for each animal, and should he decline to pay the amount the animals are removed to the nearest police station and kept there until the

amount of the fine, plus the expenses incurred in feeding and keeping them, is defrayed. Should the owner decline to pay, the animals are sold; in the event of their proving unmanageable, it is lawful for any railway official to shoot them.

Sometimes the simple child of the jungle takes it into his head to obstruct the trains and endanger the safety of the passengers by maliciously blocking the line with logs of wood, large stones and other heavy substances. For this offense they are lia-

duced by about £175,000 a year and this not by percentage reductions, for the men are working full time. The result has been brought about by the introduction of legitimate economies, common sense and modern methods, and is due to the capacity of the commission, and is a triumphant vindication of the principle of efficient non-political management. It is plain business and the result is not due to any administrative ledgerdemain.

The January balance sheet, as given by the Melbourne *Argus*, shows that with a decrease of 33,287 train miles, between the



TRESTLE BRIDGE WITH SUPPORTS WASHED OUT.

corresponding first months of 1903 and of 1904, a gross increase in net revenue of £65,362 had been achieved. These figures mean that trains were longer and heavier and the railway put about \$320,000 into their treasury, while handling all the business in sight. The total mileage operated was 3,414, and during the year previous the staff had been working short time and had been subject to percentage reductions, but when the saving was effected the men were on full time.

When railway companies have gone in for reduction of staff or short time for employees as a means of paying dividends, it has given occasion for the paradoxical saying to be used, that the cheapest way to run a railway is not to run it at all. The commissioners of the Victorian railways have proved that the better way is to take hold of the business

The boiler is 567½ ins. outside diameter in the smallest course and the steam pressure carried is 180 lbs. The fire box measures inside 6 ft. 4¾ ins. x 5 ft. 0⅞ ins., with a height of 4 ft. 9 ins. There is also a combustion chamber which is 3 ft. 6 ins. long. The tubes are 324 in number, 17⅞ ins. in diameter and 10 ft. 9¼ ins. long. The heating surface is 1,879.68 sq. ft., of which the fire box gives 166.8 sq. ft. The grate area is 32.19 sq. ft. The water capacity of the tank is 3,000 Imperial gallons. The engine and tender together are 59 ft. 10¾ ins. long, measured over buffers. The side rods are attached to outside cranks, which is common British practice, while the pistons drive on the center axle, which is cranked.

Display of Science, Industry and Art.

The opening of the St. Louis Exposition on April 30 proclaimed to the

scribing the exposition and giving all necessary information in regard to the rates and routes, also an additional slip giving the diverse routes and the rates. This book will be mailed free to any address.

Obey the Law, But Don't Get Beaten.

Senator Dolliver's remark about the three young men who started life together with stern resolves and accomplished the resolves—himself, "Hays of Wabash," and Sir William Van Horne—recalls a famous saying of the last named of the trio.

When Sir William was president of the Canadian Pacific Railway, the racing of that road's and the Grand Trunk trains into Montreal was a constant source of danger to the public. Agitation grew hot. The city passed a law to prohibit it. Van Horne called his engineers to-

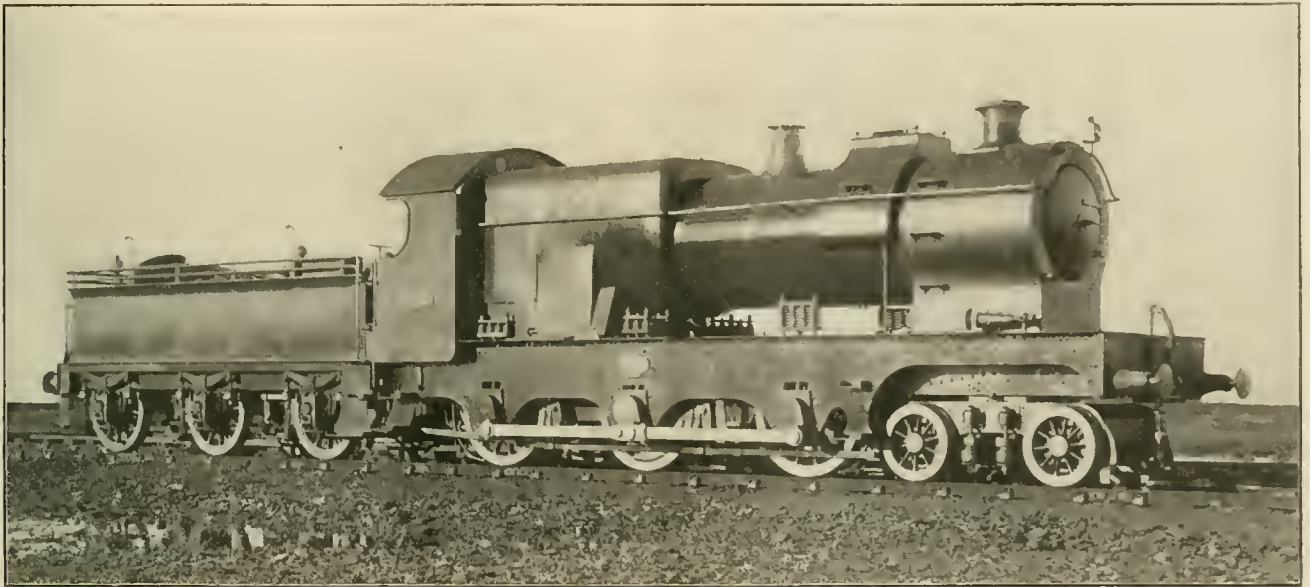

4-6-0 ENGINE FOR THE GREAT WESTERN RAILWAY OF ENGLAND

offered and handle it promptly and without waste of time, energy and money, and so reap the profit which belongs to efficient operation.

Heavy Goods Engine for the Great Western Railway of England.

The engine shown in our illustration is a simple 4-6-0 engine with cylinders 19x28 ins., and driving wheels 55½ ins. in diameter. The bogie wheels are 32 ins. in diameter. The engine can exert a tractive effort of 29,504 lbs. The cylinders are placed inside the slab frames and the springs are spiral and are placed on top of the running board. The sand box is of peculiar shape and is placed over the boiler barrel very much as a saddle is placed on the back of a horse. The steam ports of this engine are 26¾ x 1¾ ins. The exhaust port measures 26¾ x 12 ins., piston valves, outside admission being used.

visitors the truth of the promises and prophecies which the managers of this gigantic exhibition have been claiming for it. It presented a gorgeous and dazzling appearance. The beautiful buildings, and their various styles of architecture, the massive machinery, the varied industries with their factories and workmen, the costly art displays, the rare foreign exhibits, and those two novel features—the plateau of States and the Pike, which completely eclipses Chicago's Midway—amaze the visitors. The accommodations at the hotels are reasonable in price and first class. The train accommodations are perfect, and the new Wabash station, just outside the fair grounds, is where the Boston & Maine through cars enter. Any person intending to visit the St. Louis Exposition should send to the Boston & Maine Passenger Department, Boston, for their beautiful illustrated booklet de-

gether one morning and read aloud the ordinance.

"Now, men," he said, "that's the law, and you've got to obey it. I shall suspend any engineer who breaks it. That's all I've got to say except this: God help the engineer that lets a Grand Trunk train beat him into this town!"

In the bunk room of the Rock Ballast & No Dust Railway the other night, the crews of three fast freights and the engineer of a 4-4-2, were having a "bight" before going out, when the youngest fireman on the road startled the old timers by saying: "If men are the salt of the earth, women are undoubtedly the sugar. Old maids are brown sugar; good natured matrons are loaf sugar, and pretty girls the fine pulverized sugar. Pass the pulverized sugar, please."

Signals and Signaling.

BY GEORGE SHERWOOD HODGINS.
(Continued from page 226.)

TUNNEL PROTECTION.

There is probably not a person in the world who knows anything, even remotely, about railroad travel who would not view a possible accident in a tunnel with far more serious apprehension than he would look upon almost any other form of disaster connected with land transportation. It is this nameless feeling of dread in the mind of the public, inspired perhaps by the gloom of the subterranean road itself, or perhaps by the knowledge that in case of accident the way of escape is not only greatly restricted but that the chance of finding it is actually remote, which has caused not a few companies to adopt special

There is a signal tower at each end of the tunnel and the system employed is the manual controlled with full track circuit through the tunnel. The tunnel tracks form each a block; the one on the westbound track is 4,953 ft. long and the block on the eastbound track is 4,706 ft. long. The manual controlled, or the lock and block system in this case, with Sykes instruments, operates a "home" signal close to each entrance of the tunnel and the signals are made semi-automatic by the presence of an electric slot mechanism on the post of each. The normal position of the signals is at "stop" and they are only lowered for train movement.

The procedure which must be followed in order to allow a certain train, say, a through express which our friends in Great Britain might call the "10:12 A. M. mail *ex* New York," to proceed through the Bergen tunnel would be for the signalman in the tower at the eastern portal, on regular notice of the approach of the train, to electrically ask the signalman in the tower at the western portal to unlock his signal lever. This the western portal signalman can only do if the tunnel block is clear. When he does it and the eastern portal signalman lowers his slot "home" signal to the "proceed" position, on comes the "10:12 mail *ex* New York." When that train passes the "home" signal just lowered, it automatically puts that signal to "stop" behind it as it dis-

the train emerges, which machine, when the signals at the mouth of the tunnel are all in the "stop" position, is automatically put in commission. The ex-



SLOT SIGNAL GOVERNING ENTRANCE TO THE BERGEN TUNNEL, ON THE ERIE.

means of tunnel protection, usually in connection with their signal systems.

The Bergen tunnel on the Erie is the highway of that road, a few miles from New York. It was driven through the rock formation which, a little higher up, along the west bank of the Hudson river, is called the Palisades. The tunnel is a straight "bore" 4,381 ft. long, wide enough to accommodate an east and a westbound track. It has in all seven vertical ventilating shafts, the highest measuring about 125 feet. Notwithstanding the ample portals and the seven air shafts the tunnel is hardly ever clear of smoke and gas. This rock-surrounded road on the Erie is like the neck of a bottle, through which all the traffic—express, local and branch trains—must pass, making approximately 360 total train movements in the 24 hours.

appears in the tunnel. The signalman at the eastern portal cannot again pull down his slot signal to "proceed" until unlocked by the man at the other end of the tunnel, and this man cannot give an "unlock" until the train has passed out of the tunnel block. No two trains can ever be in the tunnel on the same track at the same time. With full track circuit in the tunnel, the break-in-two of a train would put it completely out of the power of either signalman to alter the "stop" indication at the entrance of the tunnel until the tunnel track was actually clear.

After a train had entered the tunnel, should it become necessary to stop it, just as it was emerging it can be done by the use of an audible signal. There is a torpedo machine on each track situated about 600 feet from the end from which



EASTERN PORTAL OF BERGEN HEIGHTS TUNNEL, NEAR NEW YORK, ON THE ERIE RAILROAD.

plosion of a torpedo would, in the confined space of the dark tunnel, give a powerful, audible, and flash light signal to those in charge of a train. The tor-

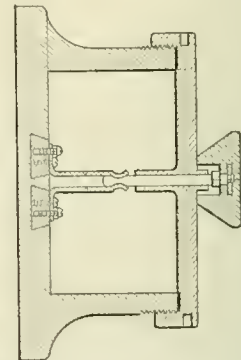

ELECTRIC DANGER—LIGHT PLUG AND PLUG BOX, BERGEN TUNNEL, ON THE ERIE.

pedo machine thus practically acts as a "distant" to the "home" signals at the mouth of the tunnel.

In addition to the regular block sig-

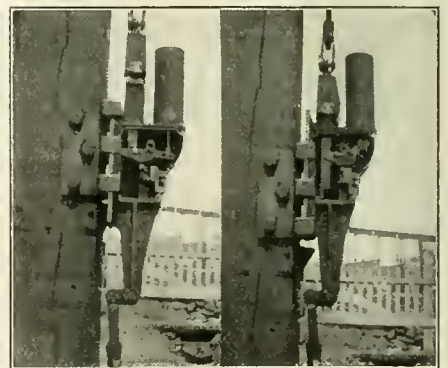

TWO POSITIONS OF ELECTRIC SLOT MECHANISM ON SIGNAL AT ENTRANCE OF BERGEN TUNNEL, ERIE.

nals, which are in themselves a guarantee of safety, the Erie Railroad officials have adopted another and carefully

worked out system of signal protection that is worthy of more than passing notice. In each tunnel tower, at all times, there are two signalmen. One keeps a record sheet and the other operates the signals. The association of two men on the work of guaranteeing a clear track is in itself a precaution, the importance of which cannot be overestimated. As each train enters or leaves the tunnel a record is kept of the time an "unlock" was asked for and given, the time the train entered or left the tunnel is recorded, and the rear brakeman on every train is required by rule of the company to appear on the back platform of the last car and wave a hand or lamp signal to the recording signalman, while the presence of the marker flags or lights are observed from the tower. This proves that the entering or leaving train is complete and that each train carries on its last car a man alive to his

that a man can reach them without stooping. Any one of these plugs when pulled out causes all the red lamps on both tunnel walls to glow. At the same time an electric gong in each signal tower rings continuously while the lighting current is on.

In order to find a plug box when a train has been obstructed in the tunnel, even in the most complete darkness, the rear brakeman has only to walk back in the center of the track. To insure his certainty of finding the plug-box a couple of two-inch planks about 2 ft. long are spiked to the ties, exactly opposite each box, in the center of the rails, so that he cannot continue his march without walking on or even

stumbling over the planks and he is sure to come on one within 50 ft. or less. The head of the plug is easily grasped as it stands well out of the box and when withdrawn hangs on a loose chain. The brakeman in pulling it out causes a continuous gong to sound in both signal towers and lights 174 red lamps ranged along each side of the tunnel.

The return of the plug to its place in the box will not extinguish the lights nor will it stop the ringing of the tower

gongs. The reason for this is that as the lighting and bell circuit is turned on by the fall of a heavily weighted solenoid core, the remaking of the plug box or auxiliary circuit will not energize the solenoids sufficiently to raise the cores, though this current will hold them up when they have been put back in place. The tower signalmen at the eastern portal after receiving full explanation and authority from the repair gang foreman are the only ones competent to extinguish the lights or quiet the bells. By rule of the company the lighting of the danger lamps in the tunnel absolutely prohibits train movement in either direction until the warning glow dies out.

The warning red lights which are placed every 50 ft. on each side of the tunnel are so arranged that the empty space on one side has opposite its center a lamp on the other. The plug box circuit is operated by an auxiliary closed circuit, energized by a gravity battery



DERAILING SWITCH OPEN NEAR ENTRANCE TO OXFORD TUNNEL, D., L. & W. RAILROAD.

responsibilities and capable of acting in an emergency.

In case of derailment or forced stoppage of any train in the tunnel, this rear brakeman is provided with an efficient means of warning all other trains or of notifying both towers. This ready ability to warn others is of the greatest value as a safety device. Every 50 ft. through the tunnel, on both sides, and placed on a level with the cab windows of an engine, there is a series of red unlighted incandescent electric lamps which are connected in series with a powerful storage battery, maintained in suitable houses near each portal. This current can be turned on and all the lamps lighted by the pulling out of a plug. These plugs are in a series circuit and each plug is contained in a box placed just below the red glow lamps. These boxes are on such a level



VIEW FROM INTERIOR OF OXFORD TUNNEL ON THE LACKAWANNA, SHOWING GAUNTLETED TRACKS.

run through plug boxes in series. This circuit energizes two solenoids in both towers, which governs the lamp and bell circuits. The storage batteries which cause the red lamps to light up are carefully maintained, and the proof of its



EASTERN ENTRANCE TO THE OXFORD TUNNEL ON THE D., L. & W., SHOWING TRACKS CONVERGING.

continual efficiency is had by causing it, as a matter of test, to light up both, interlocking towers every night. A test of the light is made every 24 hours, with record of voltage, amperage and leakage. The batteries are charged from the city lighting station every week with current

which, passing through suitable rheostats, gives the exact strength necessary to chemically separate the elements of the storage battery.

The sulphurous and carbonic acid gases which are constantly in the tunnel have a most destructive action on all

a piece of gauntleted track running through it. The corresponding rails of each track approach within 7 ins. of each other. An arrangement of this kind, while it has the advantage of economical tunnel construction, practically contracts a double track road to

can enter the tunnel without the knowledge and consent of the signalmen.

When a train approaches the tunnel on the westbound track, the derailing switch on that track is closed by the signalman in the tower. This action locks the slot signal in the "stop" position at the other end of the tunnel, and it, at the same time, permits the "clearing" of the "home" at the western portal. After the train has passed, the signal goes automatically to the "stop" position and cannot be cleared by either signalman until the train has entered the block next ahead. Although it is possible to close both derails at the same time it is absolutely impossible to signal the road as being continuous from both ends at the same time. The signalmen can hold for an indefinite time, all trains going in either direction. They can let one train at a time pass through the tunnel, but it is out of their power to let two trains into the tunnel from opposite ends at the same time. With derailing switch open on each entering line it is absolutely impossible for a train to enter the tunnel in the face of the signals set against it.

(To be continued.)

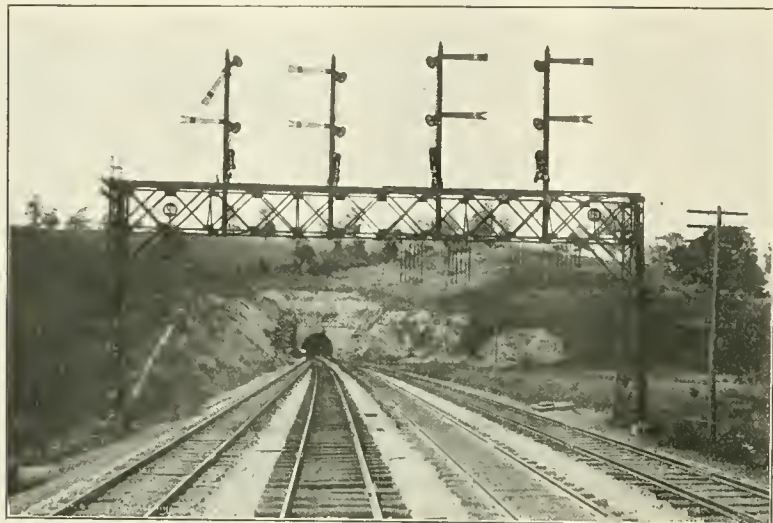

RADEBAUGH TUNNEL ON THE PENNSYLVANIA RAILROAD.
Both Eastbound and Both Westbound Tracks Gauntleted.

sorts of material which are used in the various parts of the warning light and plug circuits. Any exposed metal is doomed by the rapid corrosive action of the gases. The porcelain sockets of the electric lights crack if exposed in the uneven temperature, and lay bare metal connections which soon are eaten away. The heads of nails, countersunk in wood and covered with putty, are attacked as the putty disintegrates. The head is speedily corroded and in time the nail is actually so sharpened as to facilitate the falling away of the wood and the opening up of joints for the greedy consumption of more metal by the heavily charged gases with which they are surrounded.

The safety devices in this tunnel are continually in such an actively hostile atmosphere that it has been found necessary to design and manufacture special lamp sockets and plug boxes. The material selected is called molded mica and the vital parts are embedded in a mixture of ground mica and shellac which, while plastic, are formed under heavy hydraulic pressure into a hard, compact, air tight, gas resisting substance. These plugboxes shown among our illustrations have been designed by Mr. O. S. Conklin, the superintendent of the Bergen tunnel on the Erie.

THE OXFORD TUNNEL ON THE D., L. & W.

The Oxford tunnel on the Delaware, Lackawanna & Western Railroad, near Oxford station, is about 4,620 ft. long, and as it is only wide enough for practically one line of rails there is

a single track one, with traffic moving both ways in the tunnel.

The protection of this tunnel is provided for by the placing of an electric slot signal about 600 ft. from each of the two portals, and 50 ft. in advance of each signal a derailing switch is put in. There are two signal towers, one near each of the slot signals.

The interlocking arrangement is such that the slot signals stand in the "nor-



LACKAWANNA No. 2 EXPRESS COMING OUT OF THE OXFORD TUNNEL.

mal stop" position, and the "distant" automatic signals of the previous blocks consequently stand normally in the "caution" position. The derailing switches are both normally open so that the gauntleted track through the tunnel is at all times broken so that nothing

Early Summer Fishing in New Hampshire and Maine.

Good fishing is being reported from New England's lakes. In New Hampshire, in Lake Winnepesaukee, over thirty trout averaging four pounds apiece were caught not long ago, and the salmon are topping six and a half pounds. Newfound Lake is sending forth some likely samples, and Sunapee has her usual crowd of callers. In Sebago, down in Maine, some bouncers, weighing, 14, 12, 10, 8 and 7½ pounds respectively were landed. The fishing in all lakes in this district is first-class, and from the present outlook it appears that Moosehead and Rangeley Lakes are on the fishing list. Don't go fishing without the Boston & Maine's beautiful illustrated booklet, "Fishing and Hunting," and the new book just out, giving the game laws of Maine, New Hampshire, Vermont, Massachusetts, Nova Scotia, Newfoundland and New Brunswick. You can procure them both by sending a two cent stamp to the General Passenger Department, Boston & Maine Railroad, Boston, Mass.

The Great Western Railway Company of England have lately placed an order with the Kennicott Water Softener Company of Chicago, for the equipment of their Aldermaston (Berkshire) Water Station with one Kennicott plant with a capacity of 10,000 imperial gallons per hour. This order was secured through the Kennicott Company's London office, 29 Great St. Helens, London, E. C.

General Correspondence.

Railroad Photography.

Have you ever looked through your cab window or stood in the gangway at a meeting point, perhaps at some little way station, and watched the limited thunder by? Maybe it was a sharp frosty day and a cloud of smoke and steam rolled back while the coaches fairly slid from under it. This is one of the pleasant scenes of a railroad man's life. Have you ever wished you could record such a scene?

The photographing of trains in motion requires quick judgment, which is attained by more or less practice, and a good photographic outfit.

The chief point of interest in a moving train picture is, perhaps, the smoke. At least that is what gives it life, and in cold weather it nearly always looks well, as the steam will show whether there is black smoke or not. The best effect is one to be had on a cold morning with the train running about twenty or twenty-five miles per hour, just after a fire has been put in and the engine working in the corner.

The time of exposure has necessarily to be short, but it varies with certain conditions. A train running sixty miles an hour is going 88 ft. per second, and, if the exposure be $1/150$ of a second the train will have moved during that time about seven inches.

Where a train is running broadside to the camera an exposure of $1/800$ of a second would be none too short, and shutters are made to give as short an exposure as $1/1,800$ of a second. With a shutter working at this speed only the fastest lenses and plates can be used, but motion can almost be arrested, though, of course, any exposure is a period of time no matter how short. Thus, a train running 100 miles per hour would, in $1/1,800$ of a second move a little less than one inch, which could hardly be noticed in a photograph.

There is always a delightful uncertainty about taking moving train photos, one doesn't know till after the plate is developed how the smoke will look or whether the rods will be on the center or quarter. First attempts are more or less liable to meet with failure. One has to act quickly, especially when a train is running fast, and a novice may, in his excitement, forget to draw the slide from the plateholder or set the shutter, in either case the result is a blank, however, after a little practice things become second nature, and the

results attained are well worthy of the trouble taken in getting them.

Rawlins, Wyo.

FRED JUKES.

A Fuel Economizer.

We illustrate here an invention which has been put to a practical test on the Oregon Short Line, at Glenn's Ferry, Idaho, and which is proving itself very satisfactory. Engines equipped with this device are saving 3 and 4 tons of coal each trip. They are perfect smoke consumers, very free steamers and a peculiarity about them is the arrangement of the petticoat pipe. Usually the petticoat is so adjusted as to give the distance above the nozzle 1 in. and from base of stack to top of petticoat 3, and

ment is very simple and applicable to any make of engine. The device is covered by a patent and is the invention of Mr. M. J. Corrigan, foreman at the O. S. L. shops, Glenn's Ferry. J. A. B.

The Luckey Locomotive Stoker No. 5.

In designing this stoker I have studied carefully the different conditions of service on the various types of simple and compound locomotives. To make a special stoker for each distinct kind of engine would be quite an undertaking. Our stoker is so small and compact that it is not in the way even on the small engines, either full, half deck or deckless, while its capacity is far greater than is demanded by the largest locomotive made up to the present.

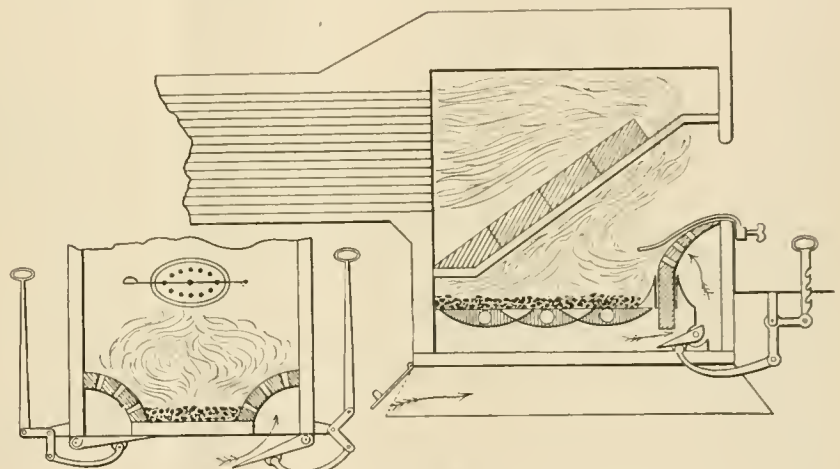

A FUEL ECONOMIZER.

sometimes 4 ins., but with this arrangement it was found necessary to put it level with the nozzle and base of the stack.

Ordinarily this would kill the engine, but not in this case. It rendered the increase of over $1\frac{1}{2}$ in. in the size of the nozzle a necessity and there are no cinders to be found in the smoke arch, as they are entirely consumed in the fire box. Perforated sheets are placed at the sides and rear of the fire box above the grates, and these admit the air, which passes through the dampers directly underneath and which can be regulated by the fireman. Generally, the harder the engine works, the wider the dampers have to be opened.

The back perforated sheet is protected by a baffle plate operated by a set screw which deflects the air under the arch and over the fire and also prevents the banking of coal on the sheet. The arrange-

Above the stoker is a hopper, into which the fireman shovels the coal. In doing so he is bringing into play an entirely new set of muscles, but after a few trips he will find his labors greatly decreased. The stoker proper has but two moving parts, viz.: A paddle-wheel to feed the coal down from the hopper and deliver it uniformly in front of the nozzle opening, and an internal admission rotary valve, discharging three different quantities of steam at each revolution, blowing the coal first to the extreme, then to the middle and then to the third of the fire box nearest the door. The force of steam passes from an adjustable nozzle at the rear end of the shovel plate, which widens as it enters the fire box, the forward end extending $1\frac{1}{2}$ ins. inside the water leg. On each side of this plate is a curved wing, adjustable to the different widths of fire boxes, and insuring an

even distribution of coal to the sides and rear corners.

In hand firing there is generally either a bank or a hole in each back corner, and by the use of this stoker we claim by its level firing at these points, substantially an increase of from four to six square feet of grate area. The stoker is rigid to the boiler head and at all times maintains the same relative position to the grate, having no contact with the deck, apron or tank. It fires with mechanical accuracy under all conditions, whether on rough track or while rounding sharp curves at high speed, where the best fireman will lose his balance and put shovel after shovel of coal where it is least needed.

While all parts are strongly made no part of it is more likely to break than any other part of the locomotive. The Luckey Locomotive Stoker replaces the regular door and swings on the same hinges. It is piped to a swivel joint above and in line with the door pin, so that in case of an accident to the machine while on short time, the stoker can be swung out of the way; an improvised door brought into use, and hand firing instantly resumed until there is an opportunity to ascertain the nature and extent of injury and make repairs.

The stoker swings, giving full door opening for the fire cleaners, fire up men and boiler makers. All journals are out of range of heat from the door, so perfect lubrication is possible. The front end of shovel plate extending 1½ ins. into the fire box, is the most forward projection. This would soon burn off were it not for the steam exhausted from stoker engine and that used to force in the coal.

The stoker compels light firing. This has time and again been proved correct. After the run over a division, in most cases, all the ashes can be shaken through the grates, instead of requiring an hour or more to remove a bank as high as the door. In this feature the stoker saves time, as it does again in firing up, for when 15 or 20 pounds of steam is raised, the stoker can be started, and by light application and the stimulus given the draught at a pressure where the blower would have no force, steam can be raised to point of blow off in less than half the time than by the old way, and when the engine is taken out on the train, instead of a heavy bank in the back part and drop grate bare, requiring use of hook or hoe, there is an even fire, which can be kept so for the entire trip.

A prominent superintendent of motive power has said: "In my opinion, any man who puts a piece of coal larger than his fist into the fire box, is burning the company's money." At

any rate, no intelligent argument can be made for the use of large chunks.

We carry light firing to a further extreme than has ever been possible by hand or attempted by machines. A thin fire can not be made with pieces of coal which will barely go in the door. We have been asked to put a crusher on our stoker, and have humored this idea to some extent. Our opposition to this plan has been proved by expensive tests, to be well founded. No one can doubt that a crusher can be made, but an engine to operate it would put too much steam into the fire box (the only logical place to exhaust it). Besides, a crusher combined with a stoker, impairs the working of the latter, and makes it a machine too large and heavy in order to withstand the strain. We have reasoned that the only proper place to crush coal is at the chute or dock, where one machine will serve for a large number of engines. Our machine handles coal up to five inches in size and gives good steaming with any grade tried so far, and satisfactory results are obtained with slack and dust, usually termed "dirt," which would soon bank a fire in hand firing.

One or two pounds of coal is put on the fire at each charge, and the door not being opened, there is more uniform steaming, a saving of fuel and flues and a further abatement of the smoke and sparks than has been demonstrated by any other method.

By attaining a higher degree of heat in the fire box and there being no air admitted, except up through the grates, an increase of from 10 to 15 per cent. can be made in size of nozzle.

There is an even temperature in the fire box and the plates and flues are not subjected to such extremes of expansion and contraction. The amount of steam required to run the stoker is returned with interest from the portions of fuel which are wasted in hand firing. By keeping the door closed, the cab is kept more healthful for the men. The fireman finds it saves his eyes and his overclothes. The engineer has a better chance to distinguish intricate signals than is possible when the door is being constantly opened.

J. R. LUCKEY.

Slipping Shut Off.

I have read with much interest the articles in RAILWAY AND LOCOMOTIVE ENGINEERING on "Engines Slipping Shut Off." I have never had the opportunity of seeing an engine slip with the throttle closed and any article I have read on the subject has failed to make it clear to me why they should slip with a closed throttle. I will say, however, that I have seen the driving wheels on an eight wheel engine (I was running at the time) while

drifting down hill one frosty morning at the rate of 30 miles per hour, suddenly ceased to revolve at the rate corresponding to the train speed, but reduced their speed to about 12 or 15 miles per hour, and an examination failed to solve the problem, that is, the driving brake was not set, everything was free, nothing binding or hot, and the engine which had received general repairs a few months previous was declared by the shop force to be in line and properly quartered. It seems to me if an engine was out of quarter bad enough to produce sliding she would assert herself vigorously by riding hard and jerky, wear rod brasses, etc. I might add that the driving boxes of this engine were fitted with sectional brasses and were a constant annoyance on account of frequent heating. I never could understand why the M. M. advocated such a brass and allowed no water to be run on hot boxes. Neither could I understand why he would undertake to inject water in a boiler over the crown sheet without an inside delivery pipe, or why his idea carried him so far away from philosophy and reason as to lead him to believe he could improve the present cylinders and pistons of locomotives by replacing them with a square box and square piston. These are facts, not fancies, and in telling them I do not wish to make insinuations. I say I do not understand, and there are readers of RAILWAY AND LOCOMOTIVE ENGINEERING that are in the same boat with me and have been made to suffer because we did not understand and appreciate things as another would have us see them, and this in the face of and in opposition to reason.

This may or may not find space in the best printed educator enginemens have access to, viz.: RAILWAY AND LOCOMOTIVE ENGINEERING, but you, Mr. Editor, will skim the lines before they reach the waste basket. Your judgment and opinion will suffice. I rest the case with you. F. W. O.

Higbee, Mo.

[This subject has been thoroughly discussed and will now be closed.—Ed.]

Tests for Compound Engines.

TEST FOR HIGH PRESSURE VALVE AND CYLINDER PACKING.

Place engine on bottom quarter, right side, engine compound, blank valve, cylinder cocks 1 and 2 open, note cylinder cocks for blow. If blow occurs at one or both cylinder cocks, rings 2 or 3 are defective. If found defective there is no need of going further with test for that valve or cylinder until defects are repaired. If no blow is found, they are O.K.

To test ring 4 and cylinder packing, move reverse lever forward just far

enough to partly open forward port. Cylinder cock 2 open. If steam blows quite strong at cylinder cock 2, ring 4 or high pressure cylinder packing is defective. To determine, if possible, which it is, place reverse lever in full forward gear, and if blow stops, cylinder packing is O.K. and ring 4 defective. If it did not stop blow, or diminish it, it would indicate defective cylinder packing. If it diminishes the blow, it would indicate both ring 4 and cylinder packing defective. If no blow they are O.K. To test ring 1, put reverse lever far enough back to partly open back port, cylinder cock 1 open, and if steam blows at cylinder cock ring 1 is defective; if no blow, it is O.K. In this last test a blow may occur at stack; pay no attention to it, as it might be the intermediate bushing blowing or blow on left side. Test left high pressure side same as right.

TO TEST INTERMEDIATE BUSHINGS.

Place engine with right pin between upper back 8th and top quarter, engine compound, No. 3 cylinder cock open. This will permit left valve to be blanked, and have reverse lever in forward motion far enough to open back high pressure port on right side. Give engine full throttle. If blow shows at stack and cylinder cock, intermediate bushing or joint around it are defective on that side. The left intermediate bushing may be tested the same way by moving engine forward one-fourth of a turn, blanking right valve.

TO TEST LOW PRESSURE VALVE AND CYLINDER PACKING.

Place engine with right main pin on bottom quarter, engine simple, cylinder cock 4 open, reverse lever just far enough forward to partly open forward port.

If no blow occurs, cylinder packing and valve rings 6 and 7 or 8 are O.K. If a blow, either valve rings 6 or 7 and 8 or cylinder packing are defective. If blow can be stopped by placing reverse lever in full forward motion, it would prove valve rings 5 and 7 or 8 and cylinder packing O.K., valve ring 6 being defective. If it did not stop blow, it would indicate cylinder packing or two of the rings, on either end of valve defective. In which case, if blow is light would report valve rings. If heavy, would report cylinder packing. If no blow occurs in either of the two preceding tests, would put reverse lever just far enough back to partly open back port, cylinder cock 3 open. If a blow occurs it would indicate valve ring 7 defective.

To test ring 8, put lever in full back gear, and if blow stops ring 8 is O.K. If it does not stop, it is defective.

The test for valve rings 7 and 8 must be considered in conjunction with any

intermediate bushing blow that may exist. Test left side in same manner.

In conclusion would say, when a defective valve ring is detected it is no use to continue the test for defective valve rings on that side, as the valves must be taken out for repairs, other defective rings would then be discovered.

These tests do not take into consideration loose or poor fitting valve bushing, cracked bridges or leaky starting valves, as it is understood such blows are very similar to the cylinder and valve packing blows, which should be looked for and located if blows are not found to be due to defective packing rings.

S. H. DRAPER,

Road Foreman of Engines,
R. M. Division Northern Pacific.
Missoula, Mont.

Top Wear of Cylinders.

In your April issue, in answer to H. D.'s question, you ascribe the greater wear on the top of a cylinder as due to the guides being lined too low. Now,

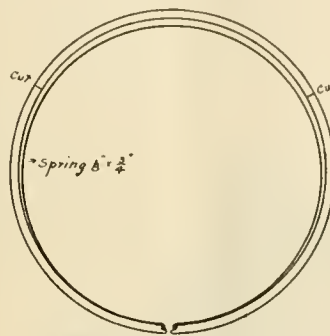

MURPHY'S PACKING RING.

this wear is a fact known to all who caliper and rebore cylinders, but it is hardly probable that guides are universally lined too low.

An examination of a piston taken from a cylinder will show that the piston is worn on the bottom side as would be expected, but the packing rings are thinnest at the top. Since the top of the ring is in contact with the top of the cylinder, it is to be presumed that the greater wear of these parts is intimately connected.

In trying to close a ring, one naturally catches it near the opening, for much less pressure is required there than if the force were applied about half way round the ring. Well, the pressure of the cylinder walls has to close the ring, and, of course, the top of the cylinder presses harder against the ring than does the bottom which is in contact with the opening. The inference is, that cylinders wear most on the top because of the unequal pressure exerted by the packing rings.

To rectify this, Mr. John Murphy, who has turned packing rings in the M. K. & T. shops at Parsons, Kan., for

about twenty years, designed and patented the sectional ring shown in the sketch. This ring has been applied to five M. K. & T. engines, and a careful examination of the cylinders after one year's hard service, showed that the top wear was entirely obviated, and not one of the five engines has ever been reported as having a leaky piston.

WILLIAM AITKENHEAD,
Machinist M. K. & T. Shops.

Gauge of Japanese Railways.

Allow me to correct an error on page 156, April RAILWAY AND LOCOMOTIVE ENGINEERING. If I am not mistaken the gauge of the Japanese railways is 42 ins., not 3 ft., as stated. FRED JUKE.

Drilling Hard Metals.

Quite frequently it happens in railroad repair shops that a piece of steel or hard casting has to be drilled. Great difficulty is found in getting the holes in the pieces, an ordinary twist drill will screech and burn up on the work, and perhaps when the job is done it will be very unsatisfactory and the time wasted and the cuss words expended won't near pay for the wear and tear on one's nerves. I have been in this position myself more than once and know what it is to be thus vexed, but I am very thankful to say that this is now a thing of the past and I propose to let you know how this seeming impossibility has been accomplished.

Being a toolsmith of long experience and being accustomed to design all kinds of labor-saving tools and dies and to oversee the machinery of them, has put me in the way of making experiments of a useful nature; hence when high-speed steel was introduced in our shop I was thoroughly familiar with the working of this steel. I was convinced it would admirably answer the requirements for an all service drill, and I was not disappointed in my expectations. It requires no amount of skill to make a flat or lip drill, but for deep and accurate drilling, a twist drill can be made that will answer every purpose of a factory-made drill. These drills can always be used for any kind of work. It pays to make them at the start and any smith should be able to get them out pretty accurately.

After making one or two, a bottom fork and a wrench to twist them, and a pair of swages $3\frac{1}{2}$ inches long for the swage part, are about all the tools he needs. After making the shank as true to the socket as possible he draws the steel slightly tapering from $\frac{1}{2}$ in. thick under the shank, a square being left to twist it by, to $\frac{3}{8}$ in. at the end and the size of the drill for the width. The twists are left about twice the distance apart that the drill is in size. As there is no possibility of truing up in a lathe,

the drill should be finished as true as possible by the smith, and the means to make it run true in the socket is as follows: Take a bar of 2 in. square iron, long enough to reach across the drill table. Drill two holes so it can be bolted to the table and the center of the iron in line with the center of the drill. Take a twist drill the same size as the one made by the smith and drill a hole through the iron. In the meantime have the smith heat his hard steel drill all over, except the shank, and when you are ready place the hot drill in the socket, start your press and feed the hot drill down through the hole up to the socket. This will make it is straight as if turned in a lathe. When the point is slowly heated white hot and cooled in oil, you have a drill that will surely cut anything you put it against.

My first drill of this description was 10 ins. over all and $1\frac{3}{8}$ in. in size and made of a scrap of air Novo steel, and the results were surprising in

results in every respect. Perhaps other brands would give equally good results. Air hardening gives as good results as the oil. While this class of steel is very expensive the amount of work can always be depended on to do from 10 to 100 times more work than any ordinary drill, as the amount of drilling done in our shop fully proves, and the best feature is that where unskilled hands are used on the presses and where formerly this class of mechanics would be at the tool fire every half hour, these drills would stand up to all the hard usage they were called on to stand and one dressing a day would be all that was necessary in the worst cases of either workman or material.

THOMAS BEASLEY.

East St. Louis, Ill.

New Zealand Engine.

By kind permission of the photographer, Master Archie Billens, I enclose photo of engine No. 217, class WA., built by the New Zealand



A NEW ZEALAND ENGINE.

the extreme. I tested a piece of steel rail and a hard piece of cast iron with an ordinary twist drill and found that on the slowest speed, 60 per minute, the drill, with three grindings, drilled the hole in the rail but burned so badly on the casting that we were compelled to give it up. Bringing our hard steel drill into requisition we finished the hole in the casting without damaging it in the least. Then, speeding the press to its highest, we drilled a hole first in the rail without damage and then the casting was tried at the same speed and we walked right through it with very little wear on the drill and no burning of the edges.

With every shop using high speed steel, if carefully marked, the scrap can be utilized to advantage in making drills of this kind and if once used I am sure they will always be used for any kind of drilling that is done in a railroad shop. I mention the brand of steel used because we use no other and it gives such good

Railway department, at their workshops, Addington, near Christchurch, Canterbury, Middle Island. The principal dimensions are: Cylinders, 14x20 ins.; driving wheels, 3 ft. $3\frac{3}{4}$ ins.; boiler, Belpaire type; grate area, $12\frac{1}{2}$ sq. ft.; total heating surface, 740 sq. ft.; boiler pressure, 160 lbs. The water tanks have a capacity of 800 gallons. The fuel space is 70 cu. ft.; total weight in working trim, 82,900 lbs. Tractive power is figured at 11,833 lbs. Slide valves are Richardson type, worked by Walschaert gear. The department are building a number of engines of a similar type, but having double slide bars, and pistons, instead of slide valves.

J. F. GREIG.

The Grade Crossings.

The problem of the grade crossing is one which has not been solved to the entire satisfaction of the railroad as yet, by any means. It is still a matter open to

discussion, and deserving of consideration. Doubtless the next few years will see many new ideas in connection with it put to practical use among the railways. The old, fundamental proposition which the railroad is continuously having to face is involved in it, how to ensure safety with economy.

The grade crossing is much more of a drain on the finances of the corporation than would ordinarily be supposed. Considering the wages of the tender, the expense of maintenance, and all, a large number of them must necessarily foot up into an expensive item, in the course of a year. Where the tracks of different railroad companies cross each other at grade, too, there is also the additional expense entailed of stopping all trains, and crossing at a slow rate of speed, as is required by the statutes of most States.

Some years ago, such a stop required by a law passed in Massachusetts, came to be known as the "Know-nothing stop," from the fact that the statute was enacted during the political supremacy of a party popularly designated as the "Know nothings." What the railroad of to-day needs to guard against is the "know nothing crossing," the continuance of a needless expense along its lines, and a draining tap upon its coffers.

As one journeys in the vicinity of the railway roadbed, he will often notice a grade crossing which must necessarily have been constructed at practically as much expense as though one of the travel ways passed over or under the other. Why was this not done in the first place, instead of being postponed to a future day, to become the source of a second outgo, later on? An overhead crossing is for the railroad a profitable investment for all time, and a species of insurance against expensive accidents, which never fails to meet its obligations.

But after all, it is not the overhead crossing, with its costly stone abutments and iron trusses, or the crowded causeway crossing, with its gates and its trusted employee to guard them, which often proves most expensive with the railroad in the end, but the lonely grade crossing in the remoter districts where no guard is required by law, or kept. These very places, so commonly regarded as practically free from all chances of mishap, time and again turn out to be costly luxuries with the railroad, on account of the unfortunate accidents which occasionally happen upon them.

Often, to one who inspects them casually, it seems to be highly improbable that any fatality could ever happen at these rural grade crossings, the way of approach to them is so open and unobstructed, and the chances of seeing or hearing an approaching train here being so practically certain, and yet they do go on occurring, year after year, nevertheless, in a manner which, when we

come to think of it, is astonishing, and almost inexplicable. Why it should be so, we ask in vain, and the question will doubtless never be answered. It has always been one of the mysteries of rail-roading.

The writer has attended a number of trials of railroad accident cases of this description, for the very purpose of hearing the evidence offered by the plaintiffs and witnesses as to the manner in which the injury occurred, and how it ever came about that the usual warnings were not heard or heeded; and has requested counsel conducting the cases to examine them rigidly on this point, with the object of obtaining all the information of this character possible. But the universal answer seems to be that they "stopped and listened, but could hear no sounds of an approaching train," nor were they otherwise led to mistrust any danger at hand, and so attempted to cross as they did.

Now it stands to reason that no man would wilfully risk his life at a grade crossing, if he had any reason to fear a probable mishap. Consequently it must be that there are occasional crossings at which the usual signals of warning are not sufficient for some individuals. To be sure, the law prescribes what precautions shall be taken by the railroad, the sign properly lettered, indicating the presence of possible danger and its nature: the ringing of the bell and blowing of the whistle; but why should the road confine itself strictly to the mere requirements of the law in this matter? Would it not be for its own benefit, at some of the more dangerous crossings to adopt additional measures for protection, as, for example, to erect at the roadside, some rods back from the rails, a large signboard, stating just the times of day, to the hour and minute, when trains are scheduled to pass this point, so heralding the danger, long before it is reached?

Why would it not be practicable, in these days of the everyday use of electricity, to connect a gong at the worst crossings with an electric attachment, which would continue sounding while a train was within some little distance, or even raise a red flag similarly, or, better still, do both? If such an arrangement was made to work reliably, and there is no reason why it should not, doubtless the legislatures would sanction its use at many points where now a flagman is required, so proving a means of large saving.

Some grade crossings are such by situation as to command an extended view of the track in either direction. To safeguard them farther than they are at present would be little short of folly. If they are not safe thus, they cannot reasonably be made so. But there are others, on the contrary, where the pres-

ence of heavy timber, or a quick turn in the road, or a sudden down grade, brings one unexpectedly onto the rails themselves. At such points additional protection would almost seem imperative.

Frequently an unruly or high spirited horse becomes unmanageable at critical moments in such places, and cannot be checked, and so an accident results; whereas, if the driver had been put upon his guard some minutes before coming into the vicinity of the track, nothing serious might have happened. The whole matter of the protection of grade crossings is one to which the railroads may still turn their attention with benefit to themselves and the community.

Salem, Mass. R. B. BUCKHAM.

Coal Picks from Waste Ends.

Like the Chicago packer, who, after utilizing all the products of the hog, conceived the idea of reproducing the squeal on the phonograph that nothing might go to waste, so the foreman blacksmith of the Chicago, Rock Island & Pacific Railroad conceived the idea of saving the waste ends of steel bars. Our illustration shows a waste end, 1½x1½x 12 ins., converted into two coal picks for the use of firemen. The bar is heat-

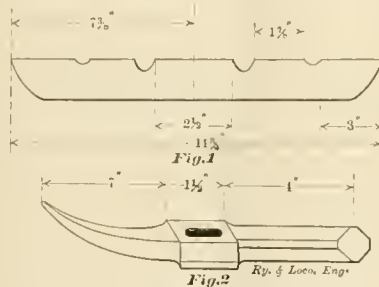

COAL PICK MADE FROM WASTE END OF STEEL BAR.

ed to the proper heat, fullered as shown, and the hole for the handle made. This completes the first operation. The second heat calls for the drawing out of the point, the finishing of the hammer end and the separation of the two picks. Fig. 1 shows first operation, Fig. 2 the finished product.

A Boiler Plate Suspension Clamp.

A rather ingenious clamp for holding boiler plate so that it cannot slip when being lifted in a shop, has recently been patented by Mr. E. E. Aires, foreman boilermaker in the Lima shops of the Cincinnati, Hamilton & Dayton Railroad. The clamp is really a lever which turns about the pivot point in the under piece. The chain or hook from a hoist or overhead traveler is attached to the outer hole, and the weight of the sheet acts so as to hold it firmly clamped in place. A sheet of any thickness can be held in this way. When the lever is perpendicular it just

touches the face of the under piece. Two clamps are, of course, required to hold a sheet.

The clamp is made of cast steel and is positive in its action and the sheet

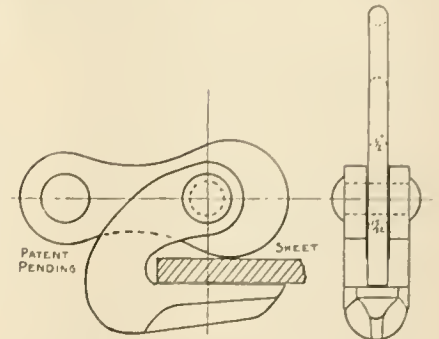

HANDY BOILER PLATE CLIP.

cannot possibly slip, as the greater the stress, the tighter the grip becomes. It is especially serviceable in handling sheets that are not straight, such as fire box, side sheets, etc. With the aid of this clamp, one man can handle and punch a sheet, while with the old style of hooks, two men are required, one to steady the sheet so the hooks cannot slip, and the other to do the punching.

Humorous Letter to Mr. Cassatt.

The *Cleveland Press* is authority for the statement that the president of the Pennsylvania authorized the payment of a claim of two years' standing, put in by a Homeville man. The letter of this patient creditor is given as follows:

"I respectfully attach papers covering claims against your company. Inasmuch as the claim has all the earmarks of a just one and having no influential friends, I beg to solicit your aid. Would you but say the word to the proper official that would cause that gentleman to loosen his grip on my \$38.13 and a prospective threadbare existence would take on a more promising hue and I would almost forgive my employer the wage reduction threatened. In return I will pray daily that those Western Union poles do not sprout and grow again. Strange as it may seem, it feels as easy to write you as to any ordinary mortal, but perhaps this is because I know this will hardly escape the waste basket of that good looking gentleman, your secretary.

"Broke, but hopeful.
"C. W. ATKINSON."

Our book, *Twentieth Century Locomotives*, encountered several annoying delays in the printer's hands, but it is now out. A superintendent of motive power who borrowed a set of the unbound proofs declared it to be the best book published on locomotive matters for ten years.

Railway and Locomotive Engineering

▲ Practical Journal of Railway Motive Power and Rolling Stock.

Published Monthly by

ANGUS SINCLAIR CO.,

174 Broadway, New York.

Telephone, 984 Cortlandt.

Cable Address, "Loceng," N. Y.
"Glasgow," "Locauto."

Business Department:

ANGUS SINCLAIR, President.
FRED M. NELLIS, Vice-President.
JAMES R. PATERSON, Sec'y and Treas.

Editorial Department:

ANGUS SINCLAIR, Editor.
F. M. NELLIS,
GEO. S. HODGINS, } Associate Editors.
JOS. A. BAKER, }

Advertising Department:

Eastern Representative, S. I. CARPENTER, 170 Summer St., Boston, Mass.

British Representative:

THE LOCOMOTIVE PUBLISHING CO., Ltd., Amen Corner, Paternoster Row, E. C., London.

Glasgow Representative:

A. F. SINCLAIR, 15 Manor Road, Bellahouston, Glasgow.

SUBSCRIPTION PRICE.

\$2.00 per year, \$1.00 for six months, postage paid to the United States, Canada and Mexico. For other parts of the world, \$2.50 or ten shillings. Single copies, 20 cents. Remit by Express Money Order, Draft, Post Office Order or Registered Letter. Mailing address can be changed as often as necessary—always give old and new address, and if you subscribed in a club, state who got it up. Please give prompt notice when your paper fails to reach you properly.

Entered at Post Office, New York, as Second-class mail matter.

Copyright by Angus Sinclair Co., 1904.

For Sale by Newsdealers Everywhere.

The Master Mechanics' Convention.

When the American Railway Master Mechanics' Association meet in convention at Saratoga towards the end of the month, they will have a program of work to operate upon which will make an interesting meeting, even if the subjects to be discussed are not of a novel or particularly interesting character. A large proportion of the reports relate to subjects carried over from last year, a practice which appears to be growing and one little to be commended. The usefulness of a question that cannot be properly discussed at one convention is problematical. The experience of the association is that second reports on subjects excite little interest and it is very rarely that anything worthy of consideration is brought out in the second threshing. The most important subject carried over is "Boiler Design," which is always a welcome topic and is almost inexhaustible in giving matter for discussion and investigation. It has been up in some form almost every year since the association was formed and there has always been good things said about it. This year the subject is unusually comprehensive, for the committee is required to investigate (1) the proper location of water glasses and gauge cocks in relation to the crown sheet and center

line of boiler, (2) the proper shape of crown sheet expressed in inches per foot of length, (3) is the automatic low water detector a desirable attachment for general use on locomotives? (4) the destruction of side sheets in wide fire boxes and the reasons therefor, (5) the best form of radial stay, (6) boiler tubes with special reference to length, arrangement and spacing to improve circulation and reduce the trouble from leaky flues. Any one of these subjects could form the basis of a valuable report.

The subjects carried over are: "Ton Mile Statistics," "Locomotive Front Ends," "Locomotive Driving and Truck Axles, and Locomotive Forgings," "Boiler Design," "Revision of Standards" and "Piston Valves." The new subjects are: "Coal Consumption of Locomotives," "Air Brake and Signal Instructions," "Electrical Equipment of Shops and Shop Power Houses," "Automatic Stokers," "Locomotive Frames," "Cost of Locomotive Repair Shops" and "Safety Appliances for Locomotive Front Ends."

The question of ton mile statistics involves an attempt to arrange some equitable basis for the mileage of switching engines. This subject has occupied the attention of the association at different times without a basis being established that was satisfactory to all parties. The past practice has been to credit switching engines with a certain mileage for every hour they have worked, which favored some engines and did injustice to others. When a committee investigated the subject of ton mile statistics last year they recommended that switching engines should be placed upon a mileage basis as all other locomotives are. Resolutions were adopted favoring the mileage basis for all road and work train engines, but the particulars of how switching engines were to be credited for work done were not worked out, and this year's report is expected to make acceptable recommendations. The committee have a most difficult task to perform and we hope they may succeed in satisfying all concerned.

Unless it be "Boiler Design" and "Piston Valves" the remaining subjects carried over are not likely to excite much attention. But piston valves is a living subject on which reliable information will be welcomed. We have not been infatuated by the improvement some people expected to be effected by the use of piston valves, but we are ready to confess that private reports received concerning their performance on some railroads during the year incline us to modify certain preconceived opinions. Piston valves have now been in use long enough to prove themselves, and the conclusions of this committee's report will exert a powerful influence upon this part of the locomotive.

Among the new subjects two concern fuel economy, one being "Coal Consumption of Locomotives," the other "Automatic Stokers." The time has arrived in the operating of many locomotives, when manipulating the fire, to obtain the best possible results from coal fed to the fire box is beyond consideration. When one man has to handle from five to nine tons of coal an hour, all he may fairly be expected to do is, to put the coal upon the grates in a way that will keep up steam. A laborer shoveling coal out of a car rarely lifts more coal per hour than a fireman of a consolidation locomotive has to handle, and the latter is expected to close the fire door between every shovelful of coal. It is useless to put pressure upon him to perform his work so that the principles of combustion shall be adhered to. The wonder grows among many people that he is able to endure the physical strain at all.

Aid to the overworked fireman is in sight in the form of automatic stokers. There are several automatic stokers on the market, entirely practicable appliances which only await good will to be made as successful as any other boiler attachment. We hear the objection repeated that the automatic stoker has not yet been properly perfected. If railroad officials were anxious to relieve the overburdened fireman they would find no great difficulty in perfecting the automatic stoker. It is for want of will that the way is not found. The automatic stoker was a much more perfect apparatus three years ago than the injector was when it first came into use. Experience in service is needed to develop weak points which could certainly be remedied without putting much strain upon the ingenuity of our inventors and mechanics.

The committee on air brake and signal instructions will be required merely to ratify the changes adopted by the Master Car Builders' Association on the recommendation of the Air Brake Association. "Electrical Equipment of Shops and Shop Power" offers the opportunity for a good report; but it is not likely to excite much discussion. Railroad mechanics are rapidly becoming familiar with electrical appliances for shop use, and the report will doubtless convey to them increase of useful knowledge.

"Locomotive Frames" is at present an intrusive subject. The enormous forces that locomotive frames have to control in the more powerful classes of locomotives are not always successfully withstood. Breakage of frames is a prevailing complaint and it is a very expensive malady. Material has not been spared to make the frames strong. Makers of steel frames have acquired great skill in producing almost perfect castings; yet the

frames break. If the committee can suggest a remedy that is not more expensive than the disease they will be accorded the heartfelt thanks of many distressed railroad officials.

"Cost of Locomotive Repair Shops" is a subject of varying importance greatly influenced by the standpoint of the party interested. It has a bearing similar to the cost of a dwelling house, which will be regulated by the taste of the person spending the money. Repair shops are generally made as costly as the management will permit. An idea prevails that elaborated repair shops, provided with all sorts of conveniences and labor saving appliances, will be less costly to operate than old shops they have taken the place of, but we never knew of a case where it worked out that way in practice. It is like the pretentious dwelling house. There are more comforts and conveniences, but they have to be paid for. We are afraid that this view will receive very little endorsement, but it is true nevertheless.

Requests That the Master Mechanics' Association Pay for Experiments.

When the committee on boiler design was continued by the Railway Master Mechanics' Association, it was expected that funds would be provided to enable the committee to carry out tests on various parts of boilers; and some disappointment has been expressed by the railroad press that the executive committee did not accede to the request for financial aid. The *Railway Age* writes as if the executive committee displayed want of enterprise in not advancing part of the association's funds to defray the expense of carrying out experiments on boilers, and that the article of the constitution regulating the expenditure of money by the association might have been interpreted more liberally. It has always been a thankless duty to restrain the spending of money, but it is only by pursuing such a policy that any association can be kept free from embarrassment. A few years ago one of our leading technical societies found itself loaded with a heavy burden of debt incurred by the laxity of the officers in agreeing to expenditure of money that the society did not possess. The duty of the executive committee of the Railway Master Mechanics' Association is to see that the funds collected are spent for carrying on the business of the association which does not include experimental research. The association has never had any spare money beyond paying current expenses, and under existing terms of the constitution the accumulation of a surplus would lead to the reduction of the annual dues. While the revenues of the association continue to be derived from the dues paid by members, it would be very un-

wise to divert any part of it to paying for experiments. The railroad companies interested in having scientific investigations carried out can much better afford to spend the money than the members of the association. The matter will be on an entirely different basis if the railroad companies agree to support the Master Mechanics' Association as they support the Master Car Builders.

The Critical Heat of Steel.

A simple experiment, but one of much value to any person seeking knowledge about the behavior of boiler steel under certain conditions, can easily be made. The experiment is this: Take a strip of good boiler steel from plate made by the best firm you know of, or can get—some people call such a test strip a coupon, and for convenience it may be $1\frac{3}{4}$ or 2 ins. wide and any convenient length.

One sample taken should be bent over cold. If it is good material it can be so bent without showing signs of distress, or in other words it will bend but it will not crack or break. Another specimen should be heated to bright red or hotter, and bent over, which it will easily stand. You have cold and hot bending, without failure of metal.

There is, however, a temperature at which steel boiler plate will not stand working at all, that is when it is at what blacksmiths and boilermakers call the blue heat. If you want to experiment with steel at the critical heat, take a test piece and grind one side or one edge bright, so that the blue color, when it comes, can readily be seen. Heat the steel until it shows the blue color, which is a temperature of about 600° F., or at least varying between 500° and 800° F., and then try to bend it, and you will break it, before you get it bent fully over through 180°. It does not merely crack when bent at the blue heat, it generally breaks.

Some people speak of this as the "rotten" blue heat, because the best quality of steel behaves at that temperature as if it were no good at all. Others go farther and speak of it as the "fatal" blue heat, because to work it at that temperature is dangerous.

This is why it is poor policy, in a boiler shop, to use lumps of hot iron to heat up corners of sheets which have to be laid up while hot. These "heaters" are slow and are generally just about able to bring on the blue heat, and when steel is worked "blue" there is sure to be trouble for somebody. Portable oil heaters are the things to use, because with them a sheet can be brought up to the proper temperature without loss of time and it can then be more quickly as well as safely worked. The time taken in making a good ex-

periment with steel at the blue heat is not time wasted. It would pay a boiler shop foreman to give his apprentices ocular demonstration of the way in which boiler plate of undoubtedly good quality will act at this truly critical temperature.

Thanks.

An honored correspondent writes that we are mistaken in making the statement that Mason's engine "Saxon" was built about 1856, and he places the date ten years later. We should be under obligations if some of our readers would give exact data about the year the "Saxon" was built. Many correspondents have sent letters correcting historical statements made in the articles on "The Growth of the Locomotive," and we propose making the corrections before the articles appear in book form. Those who interest themselves sufficiently in these articles to correct mistakes are working to conserve the truth of history. We are particularly thankful to Mr. H. F. Colvin for the good offices he has performed in the cause of true history and several others have been almost as kind as Mr. Colvin.

Supreme Court Upholds the Fellow Servant Law.

The Supreme Court of the United States has just rendered a decision which is of superlative importance to railroad employees. They have laid down the principle that a telegraph operator for a railroad company and a fireman on a railroad engine are "fellow servants," and that the negligence of the former causing the death of the latter in the operation of trains was a risk the fireman assumed, and not a ground for damages against the company. The case was that of Alline A. Dixon against the Northern Pacific Railroad Company for damages for the death of her husband, C. A. Dixon, a fireman on the road, who was killed in a collision caused by the negligence of a telegraph operator.

This decision was upholding an ancient English common law which grew up when conditions of fellow servant employment were entirely different from what they are under modern industrial life. There was a slight basis of justice in the law at the time when every servant had the opportunities of knowing the habits of every fellow servant and could guard against reckless or careless habits, but that condition has long passed. Yet, the law as interpreted by the highest court of the United States holds that every man in the employ of a corporation must be familiar with the habits of all other employees although they may be numbered by thousands, and that it is their duty to refuse to work where a person of reckless or careless habits is

employed who might jeopardize the life of his fellow servants.

To the credit of the Supreme Court, there was a dissenting opinion delivered concurred in by the Chief Justice and two others. The view was that the operator was the agent of the employer, and as such his negligence rendered the employer liable for damage or death caused thereby, certainly the common sense view. The opinion was further expressed that the court's decision would create much confusion.

Air Brake Association Experts.

The Air Brake Association held a very successful convention at Buffalo last month, and performed valuable work in the cause for which it was organized, viz.: "By co-operation with the other railway associations to furnish such information concerning the construction, best methods of operating, defects resulting from service, and most approved means of maintenance of air brakes as will contribute to the maximum of brake efficiency at the minimum expense." A variety of very useful and interesting reports was read and discussed with a thoroughness that is unique to this association. We are not acquainted with any technical association where the members in convention devote themselves so zealously to the business on hand as the Air Brake men do. They are the most independent organization of railroad men, for they provide themselves and their friends with all the entertainment enjoyed and no interest is taxed that they may enjoy pleasure along with business.

The Air Brake Association consists of men who have reached the positions they hold entirely by a process of natural selection. Most of them are mechanics who have been selected for taking care of air brakes and other complex mechanism, owing to their possessing a useful combination of skill and knowledge. Their work calls for more than the perfected skill of a first class machinist. A man may be able to do the finest work in a shop, make tools, fit up links and bearings and do masterly work on any machine tool, yet be helpless when he is sent to repair a balky air pump, a defective triple valve or an injector that fails to throw water. These are cases where reflective ingenuity is required and knowledge of the principles on which the apparatus works. The man who possesses these attributes is a natural engineer with abilities that raise him above a first class machinist. The training which an air brake repairer and inspector gives himself makes him one of the most useful employees in railroad life.

The complexities of mechanism, that are steadily increasing on locomotives, cars and shops, call for special knowledge and skill on the part of the mechanics

who maintain such mechanism in working order. Specialists are needed to care for pneumatic tools, electric mechanism, and other ingenious appliances, and the demand for men possessing the requisite knowledge is bound to increase. The men accustomed to diagnose and overcome the disorders of air brakes and such appliances are naturally the men who will be called upon for assistance when other complex mechanism gets out of order. The air brake men are accustomed to wrestle with hidden difficulties and they soon become as much at home in doctoring a dynamo or motor as they are in adjusting the disorders of lubricators and pneumatic tools.

Some of the outside speakers at the Air Brake Convention expressed the belief that they were addressing future superintendents of motive power and high railroad officials. We believe that the prediction conveyed is true; but we think that the railroad officials now in power are in need of some education concerning the valuable material for promotion they have in members of the Air Brake Association. The progress of the promotion of air brake experts is retarded by the very usefulness which ought to commend the men for advancement. An inspector is found highly efficient and extremely useful in the position he fills. A man of equal efficiency is difficult to find, and positions of increased remuneration which the air brake expert could fill with advantage to all concerned, are given to men who can be more easily spared from the work they are engaged upon. This is not fair, and we call upon railroad officials to give more consideration to the merits which commend their air brake experts for promotion.

Our railroads are more noted for the long delays that happen in the transportation of freight than for promptitude, but they have not a monopoly of slow transport. A test case was made in Germany lately to find out how long it would take to have a package carried 550 miles. Two quarts of liquid air were delivered to the railroad station at Berlin and five days later it was delivered at Berlin. We could cite cases where it took twice that time to transport a carload one hundred miles.

Agitation against smoke unnecessarily made by locomotives is progressing in St. Paul. Somebody and a railroad company or two will be wounded and an effort will be made for a few weeks to prevent objectionably black smoke, then all concerned will drop gradually back into the old easy going practice.

Thoughtfulness begets wisdom.—*Bar-naby Rudge.*

Questions Answered

(42) Investigator, Pittsburg, Pa., writes:

I have frequently watched locomotives hauling long trains and the question has come, how much of the power generated is used up in moving the motor and how much is devoted to hauling the revenue producing load? You have been recommended to me as an authority on such matters. A.—There is not much reliable information on this subject. While working at 25 per cent. cut off with a piston speed of 500 ft. per minute a locomotive is said to use up about 7 per cent. in overcoming the friction of the engine. About seven years ago a series of tests was made by Mr. S. P. Bush on the Pennsylvania Railroad to find out the quantity of coal consumed with 2-8-0 engines. It was found that 30 lbs. of coal per mile was required to move a light engine at an average speed of 16½ miles an hour. That would cover all the internal friction of the engine and the wind resistance to movement.

(43) A. A. S., Evansville, Ind., asks:

(1) What is the rule for balancing a Richardson slide valve for a locomotive, should the balanced area be enclosed by the outside edge of the strip or should it be measured from the inside? A.—The balanced area should be measured from the outside edge of the strips.

(2) Please let me know what percentage of balance these valves are supposed to have. A.—They generally have 55 per cent. of the total area of the valve face.

(44) L. B. R., Buffalo, N. Y., writes:

Please explain to me through your question department what the meaning is of the expressions ratio of adhesion and co-efficient of adhesion as applied to locomotives. A.—(1) The ratio of adhesion is found by dividing the weight on driving wheels by the tractive force developed in the cylinders. (2) The co-efficient of adhesion is found by dividing the tractive power by the weight on driving wheels.

(45) Enquirer, Calgary, asks:

What is the weight of the heaviest ten-wheel locomotive that can with safety be run at a speed of thirty-five miles per hour on steel rails, 56 pounds to the yard, Tamarac ties, two feet centers and curves from 5 to 7 degrees. A.—With track in good condition, as stated, and with a properly counter-balanced engine, the individual wheel load should not exceed 12,000 pounds, which would make a ten-wheel engine with a total weight of about 100,000 pounds.

(46) H. F. S., New York, writes:

Will you please explain what case hardening is. A.—Case hardening in general consists in introducing sufficient carbon into the outer surface of wrought iron. The carbon is given up by certain animal matters such as hoofs, horns, bones, leather, etc. The articles to be case hardened are usually placed in an iron box and packed with bone dust. A better way is to use leather and animal hoofs cut up into pieces one inch square and adding common salt in a proportion of about 4 pounds salt, 20 pounds leather and 15 pounds hoofs. Care should be taken in packing the articles so that when the surrounding material burns away the articles will not press upon one another sufficiently to bend them out of shape. The iron box is covered with a lid, and all seams cemented with fire clay. The box is then heated to redness in a charcoal or coke fire and kept there from ten to twelve hours, after which it is allowed to cool in the air. The case hardening penetrates about $\frac{1}{8}$ of an inch. A very good formula for making case hardening mixture out of chemicals is King's formula. It consists of 16 parts lamp black, 18 parts sal soda, 4 parts muriate of soda, and 1 part oxide of manganese.

(47) J. C., San Francisco, Cal., writes:

What is the proper amount of lateral motion to allow between the hubs of driving wheels and between the hubs of pony truck wheels of a mogul engine? The engine in question is a three foot gauge; total wheel base is divided as follows: pony truck to forward driver, 5 ft. 11 ins.; forward driver to main driver, 4 ft. 6 ins.; main to back driver, 7 ft. 6 ins. Diameter of drivers is 40 ins., and diameter of pony wheels 24 ins. Pony truck has swing bolster. A.—Good practice is to allow $\frac{3}{4}$ in. for cast iron driving wheels and boxes, or $\frac{1}{8}$ in. if the hubs are bab-bitted. The pony truck wheels should have about $\frac{3}{16}$ or $\frac{1}{4}$ in. This is assuming that the main drivers have flangeless tires.

(48) W. H. F., St. Paul, writes:

Can you inform me through the medium of your paper what is the process of hardening locomotive links made from steel castings. A.—Cast steel links for locomotives should be made of rather hard steel, possibly .5 to .6 per cent. carbon, depending upon the quality of the steel. If, however, the links are too soft they can be made satisfactory for service by the process known as "potashing." Ordinary case hardening is not suitable as it makes them too hard and brittle, and it penetrates too deeply. The process of case hardening, called potashing, is very much quicker than ordinary case hard-

ening with bone dust, etc. It consists in heating the article to be treated to a bright red, taking care not to let it scale, and applying prussiate of potash, which is a yellow, tough, crystalline salt (K_2FeC_6), called by chemists potassium ferrocyanid. As the potash fuses it can be spread over the entire surface, after which the article is again heated and dipped in cold water. In dipping, care must be taken not to cause the article to warp by uneven cooling. Sometimes a mixture of the yellow prussiate of potash 3 parts, and sal ammoniac 1 part, is used. Another formula is 1 part prussiate of potash, 2 parts bone dust, and 2 parts sal ammoniac. But prussiate of potash used alone is satisfactory.

(49) J. B. B., Council Bluffs, Ia., writes:

Will you please explain why steam will get under the water in a locomotive boiler, that is, why will it show the two top gauge cocks water and steam in the bottom one? A.—This condition may be possible under certain conditions. It might happen with strongly impregnated alkali water which had not been changed for a long time and which would not allow the steam bubbles to rise very fast. In this condition it would be possible for the fire box sheets to be burnt, like mud burning, owing to the water being held away from the plate by a film of steam bubbles. If steam so formed gets into the water glass it is quite probable that it will fill the bottom of the glass and hold the water above it, but this condition will be the same all through the boiler. It must not be understood that solid steam is holding solid water on top of it. The whole thing is frothy with the greatest accumulation of steam bubbles nearer the hot plates at the bottom, and the uprush when the throttle is opened carries the frothy water up, through which the steam bubbles do not readily pass. Shutting the throttle lets the frothy water drop. Water which will do this ought to be constantly changed or it should be treated before being used.

(50) W. D. S., Melrose, Minn., writes:

We have a class of engines where the main rod is connected to the third driving wheel while the eccentrics and valve gear are on the second driving axle. Which is the main pair of wheels? A.—The main driving wheels are the ones to which the connecting rod is attached. In this case the third main axle is the one upon which the pistons drive.

Between 1 and 2 P. M. there were counted in Piccadilly, London, 366 omnibuses and 1,099 other vehicles. The day's toll of twelve hours was 15,284 vehicles, without counting barrows and cycles.

Growth of the Locomotive.

BY ANGUS SINCLAIR.

(Continued from page 204.)

The proportions of grate area to boiler heating surface and the proportion of heating surface to cylinder content of locomotives were all established by a tentative process—they tried certain dimensions and those that were found to produce the best results were considered about right.

PROPORTIONS OF HEATING SURFACE AND GRATE AREA TO CYLINDER CAPACITY.

The boiler is the real measure of the capacity of a locomotive, but the cylinders are the measure of power and the proportions of heating surface and grate area ought to be based on the capability for generating the volume of steam required by the cylinders. In the early days of locomotive operating technical writers describing the working of an engine generally mentioned the volume of steam drawn from the boiler by each stroke of the piston. That practice gradually came to be neglected, probably because it involved tedious calculating, but the size of cylinder is certainly the most important feature of the design, although its existence has almost been smothered sometimes by detailed descriptions of heating surface, grate area, smoke box capacity, size of smoke stacks, exhaust nozzles and a variety of other matters that in themselves are comparatively unimportant — mere distant corollaries of the cylinders.

As the cylinders are the vessels through which the power for driving an engine is applied, many attempts have been made to use cylinders that were too large for the steam supply, but it acted like the analogous case of trying to work a horse very hard on an insufficient supply of food. For several decades a practice prevailed on American railroads which indicated that certain officials thought that by judicious humoring an engine could be made to do work away beyond its natural capacity. A locomotive with certain size of cylinders was found to be capable of hauling, say, 500 tons over the limiting grade of a division. The officials knew enough about cylinder capacity to figure that an increase of one inch in the diameter would increase the tractive power about 15 per cent. and enable the engine to haul 75 more tons. Then the cylinders have been increased without any other part being changed, and general disappointment ensued because the new engines were scarcely so efficient as those with the smaller cylinders. It was the ancient attempt of trying to force a quart into a pint bottle.

I have already mentioned that the proportions of stroke and diameter of cylinders of the Stephenson "Planet" locomotives used by the Locks & Canals Com-

pany, of Lowell, Mass., as a pattern in designing the engines they built, had the diameter about $\frac{1}{10}$ of the length of stroke and that that proportion became practically standard with all locomotive designers. It seems to have been a case of natural selection, for I never saw the figures quoted, but investigation will prove that nearly all successful locomotives have had cylinder proportions that did not vary far from those of the Planet.

It will be interesting for students of the growth of the locomotive to examine

The figures given in the annexed table relate almost exclusively to passenger engines.

NEW YORK BACKWARD IN PUSHING RAILROAD ENTERPRISES.

While the people of New England, Pennsylvania, Maryland and South Carolina were pushing forward railroad enterprises, the people of New York City continued to be very apathetic concerning railroad construction. They were enjoying the Erie Canal as an artery

AN APPIAN WAY PROPOSED.

After the war was ended General Clinton applied to Congress for an appropriation to construct a road which he called the "Appian Way" after a great Roman road constructed by Appius Claudius 300 B. C. Congress would do nothing for the enterprise but General Clinton never relinquished his efforts to have the nation undertake the great work, and on his death the idea of connecting the ocean and the lakes by a public thoroughfare was taken up by his son, known to history as Governor DeWitt Clinton.

SHORT LIVED FAME.

In passing it is well to remark that in the popular memory DeWitt Clinton is known principally through a pioneer locomotive having been named after him. It is a grim satire upon the justice of history, that the most influential promoter of the Erie Canal should have this kind of reflection of his fame. The public memory is short. Ask ten average men who was DeWitt Clinton and all answer: "I never heard of him." Among the same number of railroad men two will answer it was the name of the first New York Central locomotive.

The correctness of this statement having been questioned I tested it on my office force, and only one, the office boy, answered that De Witt Clinton was one of the Governors of New York State.

CANAL PREFERRED TO A HIGHWAY.

DeWitt Clinton after advocating for several years the construction of the

LOCOMOTIVES	Dimensions of Cylinders		Cubic Contents of Both Cylinders	Heating Surface	Grate Area	Ratio of Heating Surface to Grate Area	Ratio of Heating Surface to Cylinder Contents in Cubic Feet	Ratio of Grate Area to Cylinder Contents in Cubic Feet
	Ins.	Cn. ft.						
Stephenson's Planet, 1830.....	11 x 16	1.66	407	6.5	62.6	245.1	3.91	
Baldwin's Ironsides, 1832.....	9½ x 18	1.47	208.5	6.78	30.7	141.5	4.69	
Hinkley Antelope, 1845.....	11½ x 22	2.57	463	8.00	57.9	180.0	3.11	
Hinkley for B. & M., 1847.....	16 x 20	4.04	734	10.0	73.4	160.0	2.15	
Griggs, 1845.....	14½ x 18	3.44	550	8.75	62.8	130.8	2.52	
Schenectady Lightning, 1849.....	16 x 22	5.12	678.2	13.5	50.2	132.4	2.63	
Eddy's Gilmore, 1852.....	15½ x 26	5.6	1172	11.12	100.5	210.0	1.99	
Winans, 1848—First Camel.....	17 x 22	5.9	1025	24.5	41.7	173.7	4.32	
Caledonian, 1850.....	15 x 20	4.0	814	10.5	77.5	203.5	2.63	
Graut, 1873.....	16 x 24	5.6	948	15.4	61.5	170.0	2.75	
Northern Pacific, 1883.....	17 x 24	6.3	1335	16.0	83.5	212.0	2.54	
Baltimore & Ohio, 1891.....	21 x 26	10.42	2035.4	28.23	72.1	195.3	2.73	
20th Century, N. C. & St. Louis, 4-6-0.....	19 x 26	8.53	2035	29.0	70.0	238.5	5.47	
Erie.....	22 x 32	14.2	3230.8	54.4	59.4	331.7	3.83	
Union Pacific.....	22 x 38	12.32	3053	49.5	61.6	247.7	4.00	
Pennsylvania, 4-4-2.....	22 x 26	11.4	2640	55.5	47.5	231.6	4.87	

the development of the locomotive as found in the proportion of cylinder content to that of heating surface and grate area. I produce a table of the most important proportions of locomotives representing the whole of the history of locomotive building. The proportions of heating surface and grate area to the cylinder content are an interesting study. It will be found that the Planet had 1.66 cubic feet of cylinders and that the ratios of heating surface and grate area were 245.1 and 3.91, respectively. That was a liberal proportion both of heating surface and grate area and is close to modern practice. Locomotives that have been built with proportions radically different have been failures, the most conspicuous among them having been the "Lightning," built by Richard Norris in 1849, with 132.4 sq. ft. of heating surface and 2.63 sq. ft. of grate to the cubic foot of cylinder. With the steady increase of cylinder capacity that has been advancing for forty years, it will be seen that the heating and grate surfaces have always been made more liberal in proportion to the size of cylinders.

A table published in *Locomotive Engineering* in 1897, giving dimensions of 25 locomotives then recently built at home and abroad for different kinds of service, ten of these engines give an average of 221.32 sq. ft. of heating surface and 3.07 sq. ft. of grate area to the cubic foot of cylinder content. It will be seen in the annexed table that the vital proportions have been materially increased in the 20th century locomotives.

to draw business from the western territories and it took them a long time to learn that anything better was necessary.

Yet, the scheme of a great land thoroughfare from New York to the western borders of the State was advocated and discussed long before the Erie Canal was thought of. During the Indian War of 1779, General Clinton had led an army through the Susquehanna, Chemung and Genesee valleys

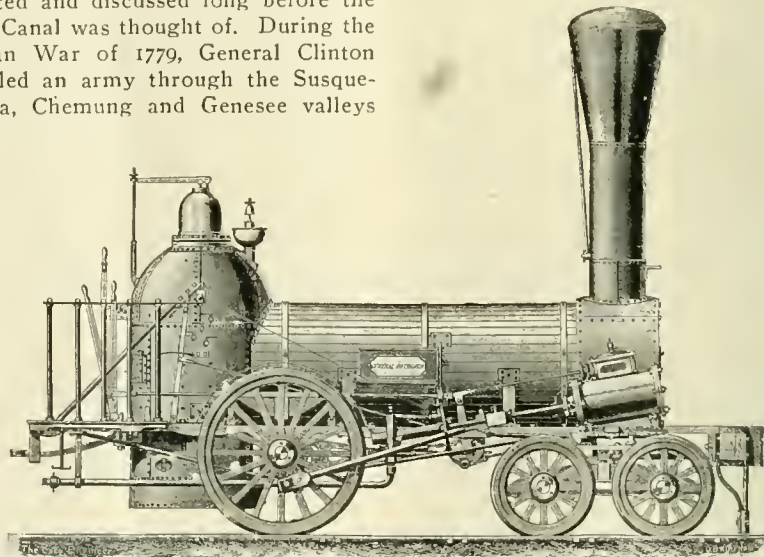

REPRESENTATIVE NORRIS ENGINE, 1842.

and he conceived the idea of connecting the seaboard with the great lakes by a thoroughfare that should pass through the valleys mentioned which are in the counties bordering the State of Pennsylvania and would form the beginning of a national avenue leading to the Pacific ocean.

Appian Way, was by circumstances constrained to divert his influence to advocating the construction of the Erie Canal, which was opened in 1825. In order to induce the legislators from the southern tier of counties of New York State to give their support to the canal scheme, Governor Clinton promised

that those who had promoted the canal would in turn endeavor to obtain through the legislature the help needed to construct the Appian Way. This brought the required support to the canal interests; but instead of reciprocating the favors the canal ring not only refused to help the land transportation interests, but always threw every obstacle they could wield against every movement originated to provide the people

various conventions attended by influential men who advocated the project and helped to influence public opinion in its favor.

At that time the proposal to build a railroad four hundred miles long was advocating a stupendous project, the magnitude and difficulties of which were little appreciated. The blind public swayed by the eloquence of enthusiasts shouted, "Let us have the great

sible to manage the politics of the State so well as they are managed now." The Erie Canal people had effected the first knock down in this fight.

NEW YORK AND ERIE RAILROAD COMPANY ORGANIZED.

After immense waste of words and efforts, the New York & Erie Railroad was organized in 1833 with Eleazar Lord, a New York capitalist, as president. Multifarious schemes were resorted to for the raising of funds, the most striking thing about them all being the meager money help that the individuals interested were willing to provide. By the sale of stock a small capital was collected, a remarkably defective survey of the line was made, and actual operation in building the railroad was begun in 1835.

The scheme as projected and promulgated to the public was the construction of a railroad from New York City to Lake Erie. Owing to an influential director of the company having been owner of some swamp land on the west bank of the Hudson river, about 25 miles from New York, the eastern terminus was made there at Piermont.

CURIOSITIES OF RAILROAD CONSTRUCTION.

When the company were ready to begin grading, some influential official conceived the brilliant idea of commencing the work in the Delaware Valley, 175 miles west of New York, in a wild, rocky wilderness, and that actually was done. All the supplies needed had to be conveyed long distances at great expense.

When grading of the Erie was begun

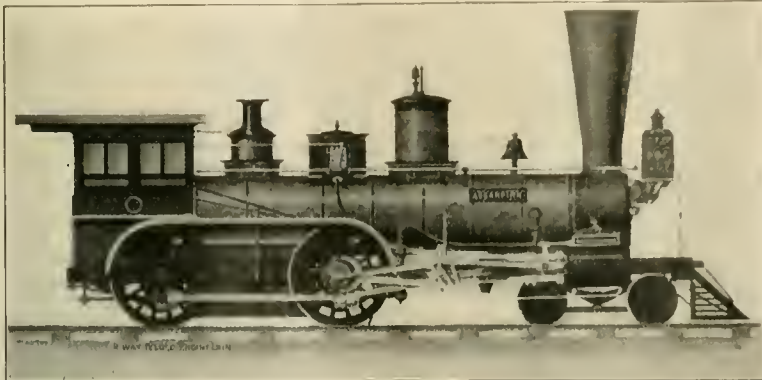

TRENTON LOCOMOTIVE FOR BELVIDERE & DELAWARE RAILROAD, 1855, WITH ALLAN LINK MOTION.

with any other means of transportation outside of the Erie Canal. The successors of the first Erie Canal ring have never deviated from the infamous policy inaugurated by the first board. They have always regarded the public as their natural prey and they have never failed to fatten upon it.

ERIE RAILROAD PROPOSED.

While part of the people were vainly urging claims for assistance in the building of a great public highway to traverse New York State, a proposal was made that public funds should be devoted to the construction of a railway over the route proposed for the Appian Way. The agitation in favor of this enterprise brought forth after painful travail the Erie Railroad.

Years before the Erie Canal was commenced that wonderful farseeing man, Col. John Stevens, of Hoboken, proposed the building of a railroad over the same route, and he presented plans which were entirely practicable as viewed from the standpoint of present experience. Most of the people regarded Col. Stevens' idea as visionary, but he had a small following which was ready to join in advocating railroad building.

AGITATION IN FAVOR OF ERIE RAILROAD.

As might have been expected the first agitation working for the construction of a railroad from the Atlantic coast to Lake Erie, did not originate in New York City. The first meeting of people favorable to the enterprise was held at Monticello in July, 1831. This was followed by meetings in Jamestown, in Angelica, in Owego, in Binghamton, and in other inland towns. There were

railroad built—by the State." The real difficulties of the enterprise began to be encountered when it became apparent that a survey of the whole route must be made. Who was to pay the expense of such a survey?

POLITICAL CONSIDERATION STOPPED SURVEY.

The United States Government was applied to and agreed to have the work done by its own engineers, but just as

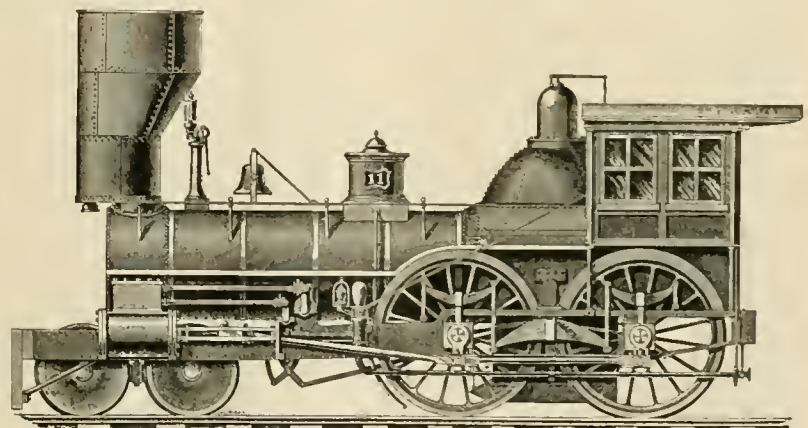

DESIGNED AND BUILT BY DAVID MATTHEWS FOR MOHAWK & HUDSON RAILROAD ABOUT 1840, REBUILT ABOUT 1855.

these men were about to enter the field an order was received from President Jackson withdrawing the engineers corps on the ground "that the building of this railroad would make a thoroughfare that would be a rival to the Erie Canal, the effect of whose political patronage would be likely to be neutralized by the patronage of the railroad, the latter not being under State control, thus making it impos-

in 1835, the engineering world of the United States had acquired considerable knowledge about the kind of road bed and track best adapted to the carrying of locomotives and cars, yet those in charge of the Erie construction appear to have learned very little from the experience of others. On the Susquehanna & Chemung sections, 100 miles of piles were driven through dry ground to take the place of a graded

road bed, at a cost estimated at nearly one million of dollars and not a single foot of that expensive trestle was ever used. Probably the construction engineers were not to blame as the plan was proposed by a celebrated military engineer of the time, who happened to be a friend of the Erie president. Many other very expensive things were done which proved how slowly information concerning railroad building was circulated.

ERIE RAILROAD DESERVED STATE AID.

If ever a railroad deserved State aid that was the Erie, for its services were badly needed in a great stretch of country that had helped to pay for the Erie Canal but had reaped no benefit from the taxes paid to build that water way. But the Erie Canal interests were keenly watchful to oppose anything likely to favor a railroad thoroughfare in the State. Yet, like most other combinations kept in life through the profits of public plunder, the Erie Canal ring were short sighted and their leaders failed to recognize what was destined to be their most dangerous rival. They pursued the Erie railroad project with persistent malevolence, but they failed to perceive that the short links of railroad built close to the banks of their own big ditch might be joined together in a continuous chain extending from the ocean to the lakes. The Mohawk & Hudson, the Utica & Schenectady, the Syracuse & Utica and other small lines reaching towards Buffalo were permitted to proceed unmolested to eventually form a through line which dried the heart of the Erie Canal and

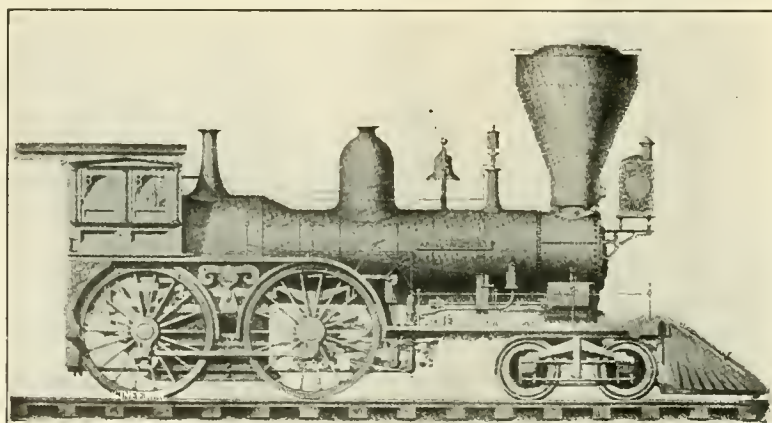

ANGLO-AMERICAN McQUEEN (SCHENECTADY), 1856.

left it merely a streak of stagnant water fit only as a false pretense for purposes of robbery under the guise of taxation.

(To be continued.)

In the operating of the ordinary locomotive one pound of coal maintains 1 h.p. for from 12 to 15 seconds. This is equivalent to from 4 to 5 lbs. of coal per horse power hour.

Give the Fireman a Chance.

Quite frequently we see articles of criticism on firemen presumably from engineers and there was one in particular in your May issue.

There is an old saying that a poor workman always finds fault with the tools and we apply the same in this case. We have a number of engineers

in the art of firing and we appreciate the fact that RAILWAY AND LOCOMOTIVE ENGINEERING has done its part in that line, but we dislike the idea of some one who perhaps never really fired an engine in his life endeavoring to tell how to do it, or to describe how he used to do it.

Being a constant reader of your val-

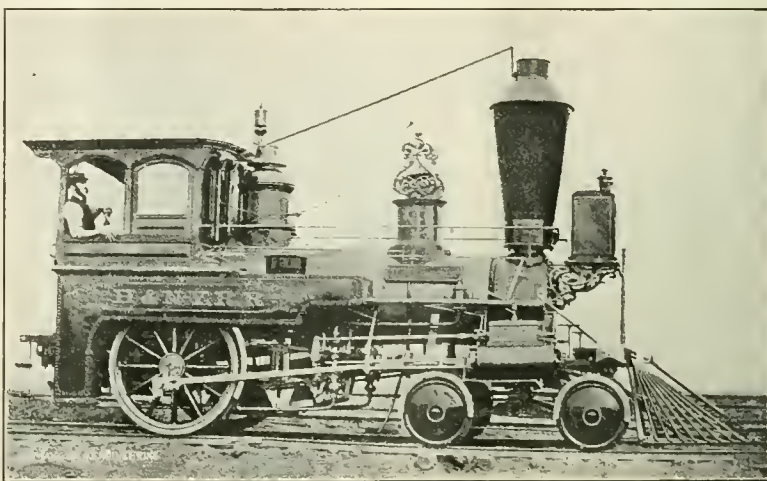

HACKENSACK, BUILT BY ROGERS IN 1860, FOR N. Y. & HACKENSACK BROAD GAUGE, NOW PART OF ERIE.

all over the country who are continually finding fault with the fireman, always telling how it ought to be done and perhaps if they were put to the test they could not keep an ordinary cook stove hot.

The fireman of to-day is up against a pretty hard proposition and the work is hard enough without his being harped upon by some one who if he did his

able magazine I thought I would write a few lines on this subject and hope no one will take offense at it.

M. L. HOULIHAN.

The Extra Fireman.

In regard to the item on page 207 in the May issue of RAILWAY AND LOCOMOTIVE ENGINEERING by L. W. T., we would say he has a very poor opinion of extra firemen. The division that we work on has 100 extra men and some of the heaviest and fastest passenger runs in the country west of Chicago. When a regular man lays off the extra men do this work. Our division is 206 miles long and if our road foreman did not have confidence in the extra men we can't say what their show would be. We work for the C., B. & Q. Railway and they give each man a trial trip, and if he does not make a success of it they try him on a switch engine for a while. We should think from L. W. T.'s letter that they used hard coal on his road, but it would not be very pleasant for any fireman to work with a man that has such an opinion of the man with the scoop.

L. C. S. H. A. F.
A. H. M. W. W. M.

Galesburg, Ill.

Andrew Carnegie says that steel has a soul. The same idea was expressed by Francis Horner, who said: Iron is not only the soul of every other manufacture, but the mainspring of civilized society.

own part and kept his own side swept clean would find sufficient work to keep him busy.

Perhaps those same fault-finders handle an engine in such a way that no fireman can do good work. My advice would be for all to work in harmony and each to do his own part the very best he can and all will go well. It is all well and good to instruct firemen

Air Brake Department.

CONDUCTED BY F. M. NELLIS.

The Air Brake Convention.

The Eleventh Annual Convention of the Air Brake Association convened in Buffalo, at the Niagara Hotel, Tuesday morning at 9 A. M., May 10, with President E. G. Desoe in the chair.

Mr. Desoe opened the convention in formal order and delivered a lengthy and splendid address. He dwelt on the

two be on hand at the Master Car Builders' convention to give such aid as lay in their power to assist that association in air brake matters, thereby co-operating more closely.

3d. That a standing committee of two should report at each convention, in a concise form, a report which would chronicle all air brake events occurring

jects on which papers had been read at preceding conventions; also, that a page be given over to the names of presidents who presided at each convention.

5th. That the book on progressive form of questions and answers on the air brake be revised and brought up to date as early as possible.



AIR BRAKE ASSOCIATION OFFICERS, 1903-'04.

L. M. Carlton, 2d V.-Pres.

F. M. Nellis, Sec'y.

E. G. Desoe, Pres.

W. F. Gross, Asst. Sec'y.

John Hume, Jr., 1st V.-Pres.

association's work during the past year, and the events in the air brake art during the same time. His address was concluded with admirable recommendations as follows:

1st. That a committee be appointed to revise the constitution and by-laws.
2d. That a standing committee of

during the year, as he believed this was in the province of the Air Brake Association and would thereby keep its members and other readers of the association's proceedings up to date in air brake matters.

4th. That the proceedings of each year should contain an index of all sub-

6th. That a committee be appointed to formulate and introduce the new feature of recommended practice, to formulate and keep up to date the recommended practices in air brake work, as advised by the association members.

7th. That a change be made from the ordinary practice of basing the braking

power for 90 per cent. for the light weight car be changed to base the braking power on a permissible amount of dead weight resting on each pair of wheels.

A committee was appointed to act on

and two persons of experience should be on the rear platform.

2. All back-up hose should have a three-quarter-inch minimum opening and a warning whistle.

3. The whistle and brake should be

initial application being about 200 feet, or about three coach lengths from the start, the engineman to stop if a slow down is not felt within this distance.

7. The brake valve handle should be carried in running position, except following a dead stop, or slow down, and signal given to continue backing. Following either, the engineman should use the full release, temporarily, as in making a regular brake release to keep from sliding wheels with brakes stuck. The engineman should apply brakes when an emergency arises and is not noticed by rear man.

8. Trainmen should understand that to operate the brakes from the back-up hose, with the handle of the brake valve in running position, the valve should be opened gradually; also that the opening should be gradually increased until the valve is either wide open, the train slowed down as much as is desired, or has stopped. It must not be opened and closed. In case they have applied the brakes too hard, closing the back-up hose will allow the brakes to release and re-charge. The rapidity with which the valve should be opened will depend on the speed and length of the train and the distance there is to stop in. In case of emergency, it should be opened wide instantly.

9. When a train is to be finally coupled to other cars, or rest against a bumping post, it should be slowed

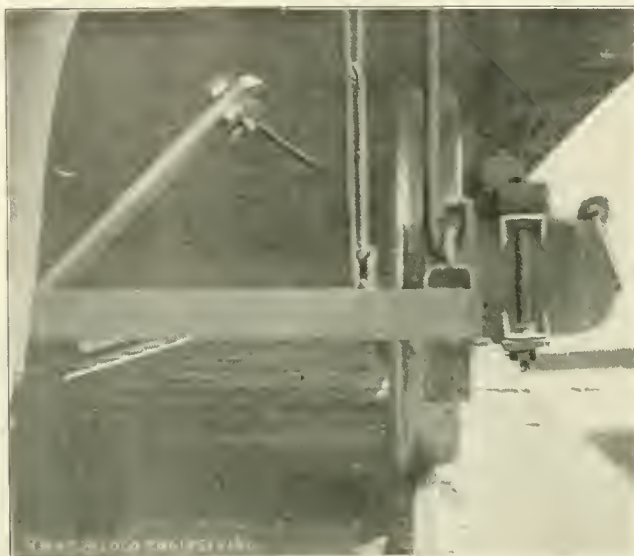

THE REASON WHY SOME BRAKE SHOES WEAR UNEVENLY AND PRODUCE FLANGES.

the recommendations of the president, and each recommendation was endorsed by the committee and afterward adopted by the association, committees being appointed to carry out in detail the president's recommendations.

HANDLING PASSENGER TRAINS WITH BACK-UP HOSE.

The first paper presented to the convention was that on handling passenger trains with back-up hose. The committee said in part:

"Owing to the increased passenger business throughout the country, the congested business district through which the passenger trains must pass, backing from storage yards to depot or vice versa, or backing over interlocking plants or toward signals, the subject of backing passenger trains with safety and dispatch becomes an important one.

We must consider the safety of the train and the many things to which the train might do damage, the maintenance of air pressure in train line and auxiliaries with which we will be enabled to make required stop or sound a warning whistle, the ability of the operator of the "back-up hose" to apply the brakes or release them in any desired space of time he may deem advisable, and also the sliding of wheels.

Summing up, the committee recommended as follows:

1. No passenger trains should be allowed to back a very considerable distance without a suitable back-up hose,

operated with the same movement of the cock handle.

4. The train hose should be blown out before attaching back-up hose.



SCRAP HEAP SHOES, SHOWING UNEVEN WEAR, DUE TO TOO GREAT DISTANCE BETWEEN BRAKE SHOE HEADS.

5. A terminal or road test of brakes should be made from the locomotive, and afterwards, a test with the back-up hose, using the standard code of signals of the road, in question.

6. A running test should be made, the

down under absolute control and then slowly moved toward its objective point.

The committee consisted of L. M. Carlton, G. R. Parker and J. W. Libby.
(Continued on page 293.)

Duplex Straight Air and Automatic Brake.

On many locomotives employed in switching service almost exclusively, a straight air brake alone would be all that was needed were it not that such engines are frequently required to charge up and test the automatic brakes on trains made up in the yards and, occasionally, are required to haul these trains to different transfer points, operating the automatic brake on them while so doing.

While engaged in regular switching service the straight air brake is entirely satisfactory for this service, and that portion of the brake apparatus that properly belongs to the automatic brake alone, consisting of the tripic valves, auxiliary reservoirs, and the piping and cutout cocks for them, is not needed on the engine and tender.

It is convenient, therefore, in many

instances, to have switching engines equipped with a brake of such design that the engine and tender will have straight air only operating on it, and piped so that when a train, upon which the automatic brakes should be operated, is attached the brakes may be coupled up, charged up, and then, in combination with the straight air brake upon the engine and tender, be operated simultaneously by a single brake valve, the same method of handling the brake valve to be observed that is used in handling the automatic brake valve.

From this diagram it will be seen that the usual air pump, main reservoir, and pump governor are required. In addition to these, there is required a duplex pressure controller, one pressure top of which is adjusted at 50 pounds and the other at 70 pounds, placed in the return pressure pipe from the main reservoir back to the engineer's valve; a brake valve, as already mentioned, of special design having two brake pipe connections, one to the driver and tender brake cylinders, known as the straight air brake pipe, and the other to the automatic brakes, and known as the automatic brake pipe; a safety valve with hand release; together with the usual stop and cutout cocks, and one Y cock. The safety valve, screwed into the

tion, between the duplex brake valve and the Tee from which the pipe connection to the 70 pound pressure top of the pressure controller is made, there is a cut-out cock, which when closed cuts off air from the automatic brake pipe and all connections thereto. The small pipe from the automatic brake pipe to the 70 pound top of the duplex pressure controller has a 1/4 in. cutout cock in it, and between this cutout cock and the pressure top there is a Tee connection having a branch pipe to the 1/4 in. Y cock. Through this Y cock, properly turned, the automatic brake pipe communicates with the black hand of the air gauge.

In addition the automatic brake pipe has the usual hose connections, angle cocks, etc., necessary to operate the automatic brake.

Referring to this Piping Diagram, showing the various connections, etc., the operation of the Duplex Straight Air and Automatic Brake, when used

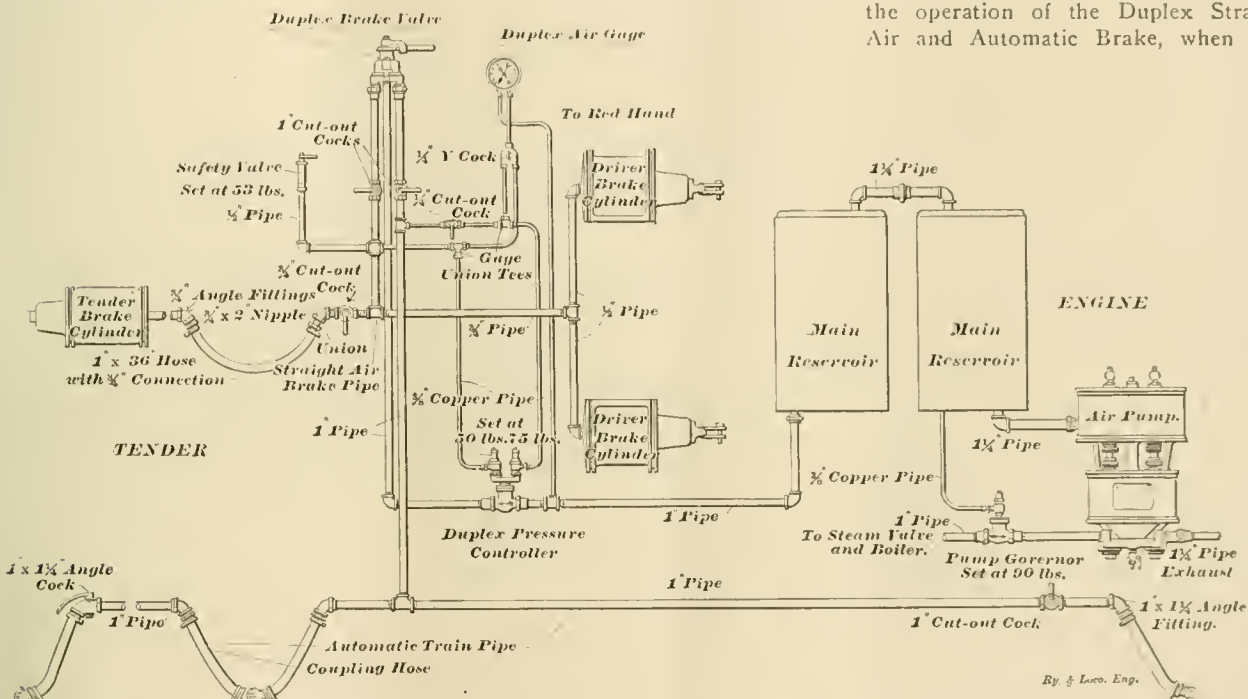

NEW YORK AIR BRAKE CO.'S DUPLEX STRAIGHT AIR AND AUTOMATIC BRAKE FOR SWITCH ENGINE AND TENDER.

instances, to have switching engines equipped with a brake of such design that the engine and tender will have straight air only operating on it, and piped so that when a train, upon which the automatic brakes should be operated, is attached the brakes may be coupled up, charged up, and then, in combination with the straight air brake upon the engine and tender, be operated simultaneously by a single brake valve, the same method of handling the brake valve to be observed that is used in handling the automatic brake valve.

To work simultaneously a combination of the straight air and the automatic brake, a brake valve of special design is required and a special system of piping and pressure control is necessary. In the Piping Diagram 116 is shown the method of piping the New York Air

straight air brake pipe as shown in the diagram, is set at 53 pounds, and is provided with hand release. There is a pipe connection from the straight air brake pipe to the 50 pound pressure top of the duplex pressure controller, and a branch from this pipe connection to the Y cock, and black hand of the air gauge.

Between the duplex brake valve and the Tee connection, into which the safety valve and straight air pressure controller pipes are screwed, there is a one inch cutout cock, and there is a 3/4 in. cutout cock in the straight air brake pipe at the hose connection between the engine and the tender. The cutout cock in the straight air brake pipe, nearest the brake valve, cuts out both engine and tender brakes and that next to the hose connection, the tender brake only.

In the automatic brake pipe connec-

only on the engine and tender, is as follows: The air pump is started in the usual manner compressing air in the main reservoir to the amount for which the pump governor is adjusted, usually 90 pounds. When this pressure has accumulated in the main reservoir the pump governor, operated by main reservoir pressure direct, will close off the steam from the pump and prevent further increase in main reservoir pressure.

The air flows from the main reservoir through the return pressure pipe and duplex pressure controller to the duplex brake valve, and to the red hand on the air gauge.

The 1 in. cutout cock in the automatic brake pipe is closed, so that the automatic brake pipe is not charged, except for the short length between the brake valve and cutout cock.

The brakes on the engine and tender can now be applied and released in the usual manner, by straight air.

Moving the handle of the duplex brake valve to service application position, opens the port leading to the straight air brake pipe gradually, so that air may pass into the driver and tender brake cylinders direct from main reservoir and charge them to the required pressure, or to the limit of the straight air pressure controller top if desired.

When the pressure in the brake cylinders reaches 50 pounds in any brake application, the straight air pressure top will operate to close the pressure valve and prevent further flow of air to the brake cylinders.

When pressure in the engine and tender brake cylinders exceeds 53 pounds, from any cause, the safety valve will operate automatically to relieve the pressure.

When the straight air brake is used singly the $\frac{1}{4}$ in. Y cock is turned so that the black hand of the air gauge is connected to the straight air brake pipe, and this hand will then register brake cylinder pressure.

The operation of the straight air and automatic brake in combination, is as follows:

With the 1 in. cutout cock in the automatic brake pipe, under the brake valve, and the $\frac{1}{4}$ in. cutout cock in the pipe from the automatic brake pipe to the automatic pressure top of pressure controller, and to the Y cock open, and with the Y cock turned so as to bring the black hand of the air gauge into communication with the automatic brake pipe, the automatic brake on the train, and the straight air brake on the engine operate in combination simultaneously with one and the same movement of the brake valve handle, this movement of the handle being the same as that required to operate the automatic brake.

When the straight air and the automatic brakes are being worked in combination, the 70 pound pressure top of the controller will operate to close off the flow of air to the automatic brake pipe when the pressure therein reaches 70 pounds; but the pump will go on and accumulate pressure in the main reservoir until that pressure reaches 90 pounds, thus providing an excess pressure with which to release the brakes promptly and recharge the auxiliaries quickly.

Service applications with the straight air brake alone or with the straight air and automatic brake combined may be made as gradually as desired, the triangular shaped ports in the brake valve enabling the engineer to equalize the discharge of air from the train pipe in a satisfactory manner. Emergency applications are made the same as with any other air brake valve, by simply moving

the handle quickly to the emergency position.

Should it be desired to release the brakes on the engine and tender without releasing the train brakes, while the brake valve handle is on lap, it may be done by opening the hand release on the safety valve.

The course which the air takes in passing through the piping, and the method of manipulating the different cut-out cocks will be easily learned from a study of the piping diagram, aided by the description of the operation given above.

J. P. KELLY.

Watertown, N. Y.

Basis of Unbraked Weight Per Axle Versus Ninety Per Cent. Plan for Passenger Equipment Cars.*

For several years past the writer of this paper has been impressed with the belief, and has expressed it upon many occasions in meetings with air brake men, that the present practice of basing braking power for passenger equipment cars upon 90 per cent. of the weight of the car is not the most advantageous and is not the best available one for calculating braking power on modern passenger equipment cars. The percentage method was adopted many years ago when freight cars and passenger cars of comparatively light weights were the rule, and was at that time perhaps very satisfactory, but it has been extended to the heavier car service with no modification and with apparently little thought as to its perfect adaptability to these cars. It is the writer's belief that the air brake art has sufficiently progressed and has now reached a stage where profitable consideration might be given this subject with especial reference to a decided betterment in the braking of heavy passenger equipment cars.

The 90 per cent. basis permits the heavy car to carry more unbraked weight than the lighter car. It will be readily seen that 90 per cent. of a car weighing 100,000 pounds leaves 10,000 pounds unbraked weight, while 90 per cent. of a car weighing 50,000 pounds leaves but 5,000 pounds unbraked weight. Thus, the lighter car is obliged to brake heavier per wheel than the heavier car, and the result is that the lighter car is the one whose wheels are usually skidded. It is seldom, if ever, that wheels are skidded under a very heavy car in a train containing lighter cars.

It would seem that a better method, based on the dead weight carried per axle, would be a more correct and profitable plan. If on a 45,000 pounds car braked at 90 per cent. of its weight, each axle carrying but 1,250 lbs. of dead or unbraked weight, the wheels do not slide,

* Paper presented by F. M. Nellis at the Air Brake Convention, Buffalo, N. Y., May 11, 1904.

it would seem logical that the wheels under a car of 100,000 pounds weight could brake to a limit which would permit of it carrying but 1,250 pounds of dead or unbraked weight also. This would give a constant and unchanging basis, unlike the 90 per cent. basis, which is an erroneous and a misleading one, varying in direct proportion and degree with the weight of the car.

In discussing this theory with air brake men, nearly all have conceded the apparent inferiority of the 90 per cent. basis, and recognized the possible superiority of the uniform unbraked weight plan; that is, persons thought it looked well on paper, but no one seemed sufficiently enthusiastic over it to give it a practical trial. This is as far as the author met with any encouragement in the new project until two years ago, when Mr. George W. West, superintendent motive power of the New York, Ontario & Western R. R. at Middletown, N. Y., gave him permission to equip a train whose braking power should be based on the unbraked weight per axle plan. With the generous and able assistance of Mr. West, Mr. J. C. Moore, foreman of car shops at Middletown, and Mr. Wyatt Carr, air brake inspector, the writer has been able to not only equip and place an experimental train in active every day service, but has coincidentally proved out in actual service a number of other new related ideas of considerable value.

This experimental train has been an ideal one for the purpose sought. The widest range of car weights were secured, the lightest car weighing 47,000 pounds and the heaviest car 103,000 pounds. All sizes of passenger equipment car cylinders, embracing 10 in., 12 in., 14 in., and 16 in. cylinders, were used. Prior to the beginning of the experiment, the lighter cars using 10 in. cylinders were skidding wheels badly, and the braking power had been reduced as low as 67 per cent. on one of the cars, in an attempt to get away from the trouble. No trouble was ever experienced from wheel sliding on the heavier cars.

Another interesting feature in connection with this work was that of basing the braking power on a 50 pounds piston pressure in service application, instead of the usual 60 pounds in emergency application. It is well known that the larger passenger brake cylinders do not develop full 60 pounds pressure in emergency application from a 70 pounds train line pressure, although 60 pounds is obtained in the 8 in. freight cylinder and is closely approached in the 10 in. passenger cylinder; but in the 12 in., 14 in., and 16 in. cylinders, 60 pounds is only approximately reached. Hence, it is believed by the author that the truer and more practical cylinder pressure

basis is the 50 pounds in service application. An emergency application, giving approximately 20 per cent. higher piston pressure, due to reinforcement of the train pipe pressure being vented to the brake cylinder, this reinforcement falling off in direct proportion as the larger cylinders are employed, still gives the usual quick action gain, and is a direct gain above the braking power which the cylinder derives from the auxiliary reservoir in service application. It would seem a preferable plan to base the braking power on the service application, as that application is probably made a thousand times to the emergency being made once in service. On this basis the brake is dealt with as a service brake, meanwhile losing none, and, in fact, even gaining in the usual proportion as an emergency brake.

The brake cylinder of each car in this train was equipped with a Westinghouse high speed automatic reducing valve, which was set at 50 pounds. This protected the wheels when hand brakes were carelessly left set, and it also gave a maximum uniform cylinder pressure at all times regardless of the variation in the piston travel. This was considered a very good safeguard as was subsequently proven in the experiments.

Fifteen hundred pounds unbraked weight per axle was assumed, being based on the unbraked weight of a light car. We do not know whether the absolutely safe limit has been reached, but the desirability to give the scheme full opportunity to prove its success and to place no unnecessary stumbling blocks in its path at the outset, this assumption of 1,500 pounds unbraked weight per axle was regarded as safe, adequate and logical.

One prominent feature with the new plan is that all cars brake uniformly with respect to the pull on the drawbar, there being an absence of surging of the train during brake application, due to the unequal braking of the several cars in the train. With the new plan each car appears to be doing its own share of the work of stopping the train. The writer has been brought to a belief that all slid flat wheels are not primarily due to high braking power, and that many skidded wheels are caused by the surging and jerking of trains whose cars are not uniformly braked. Take for example a locomotive pulling a train up a heavy grade. If the engine once slips, the slack of the train will run in, due to the spring draft gear being relieved of tension, and a surging back and forth is set up at different points in the train which pulls the engine off her feet almost as soon as she recovers from one fit of slipping. The surging of the slack in the draft springs of the cars and which causes a slipping of the locomotive in pulling a train, will conversely set up during brake

application and break the adhesion between the wheel and the rail. This adhesion would have proceeded harmoniously had it not been interfered with by this outside influence, which resulted in the wheel being "pulled off its feet."

In presenting this paper the writer realizes that he is neglecting a number of important features in relation to his subject, such as co-efficient of brake shoes at high and low speeds, and metals of the brake shoe and the wheel tire. He has also intentionally neglected to discuss bad condition of rail, poor handling of the brakes, etc., which might be deemed of great importance in connection with this subject. But as these features exist in all kinds of braking and with all kinds of braked cars, the writer has believed it is a better plan to neglect them as having no greater importance with this subject than with other brake subjects of a similar nature, and as a subject whose conditions he does not attempt to correct, except incidentally. He has sought to make prominent to this convention the advantage of the practical and tried out plan of braking cars on a basis of dead or unbraked weight per axle on cars of all weights, over the 90 per cent. plan.

The total train weight of all the cars was 490,020 lbs. The total braking power of all the cars, service application, old plan, was 294,300 lbs., or 60 per cent. That of the new plan was 436,292 lbs., or 89 per cent. The additional braking power produced on this train of cars by the new plan was 141,992, or 27 per cent.

QUESTIONS AND ANSWERS

ON THE AIR BRAKE.

(47) J. H. M., Philipsburg, Pa., asks: What is a triple valve? A.—The triple received this name because the valve performs a triple function. It charges the brake, supplies the brake and releases the brake. To perform these three functions the air passes through the valve three times; hence its name.

(48) G. W. K., Washington, D. C., asks:

How will leaky rings in the steam cylinder affect the speed of the pump and the amount of air that can be compressed? A.—Of course, leaky steam piston rings will cause a loss of steam and a consequent decreased speed of the air pump.

(49) G. W. K., Washington, D. C., asks:

What effect on the pump will a steam pipe 15 feet long, with 10 feet outside of cab have? A.—This proportion of pipe inside and out should have no effect on the running of the pump, providing the diameter of the pipe gives sufficient volume of steam to the pump.

(50) E. N., Los Angeles, Cal., asks: What is meant by the word "non-re-

turn" check valve when used in connection with the New York triple? A.—The non-return check valve (117) is the valve which prevents the return of pressure from the brake cylinder to the auxiliary reservoir in the New York triple after an emergency application, the same that the non-return check valve (15) in the Westinghouse triple prevents the return of brake cylinder pressure to the train line after an emergency application.

(51) W. T. A., Harrisburg, Pa., writes:

We had an excursion train of fifteen coaches, and had trouble with our high-speed brakes sticking. We cut out four brakes and then the brakes did not stick. A.—Doubtless, the trouble was caused by the failure of the air pump to maintain as high a pressure as it should. In other words, in going to the high-speed brake, the present air pump, unless it is in very good condition, will not readily pump up to and maintain 110 lbs. train-line pressure, 130 lbs. main-reservoir pressure, as easily as it could a 70-lb. train-line and 90 lbs. main-reservoir pressure. By cutting out the cars you have merely reduced the work required of the pump, and this is a very bad remedy. Instead of cutting out brakes, it would be much better to improve the condition and thereby increase the efficiency of the air pump, by boring out the air cylinder and fitting new packing rings into it.

(52) G. E. K., Philadelphia, Pa., writes:

We tried to set a high speed reducing valve in the air brake room, and had it set exactly at 60 lbs.; then we screwed on the cap of the adjusting screw and the valve closed between 65 and 70 lbs. every time we tried it. Then we screwed off the cap, and before re-setting the adjusting screw we tried it again and found the valve would blow back and close exactly at 60 lbs., without touching the screw. Then we put on the cap again and it would blow back to about 67 and close. Why was this? A.—Doubtless you neglected to remove the small cork from the waste port in the bottom cap of the adjusting screw, thus bottling up on the under side of the piston such pressure as leaked past the packing rings, thus interfering with the action of the valve. When the cap was removed, this leakage was allowed to escape freely and the valve would act properly. Care should be taken to remove this small cork, else unsatisfactory results will be obtained.

On account of the Air Brake Convention matter, a number of questions and answers have been crowded out of this issue but will appear next month. Correspondents may expect replies by personal mail.

Divided Four-Cylinder Compound for the N. Y. C. & H. R. R.

The engine here illustrated was built by the American Locomotive Company at their Schenectady shops from designs made by Mr. Francis J. Cole, the me-

chanical engineer of the company. The engine was built for the New York Central Railroad, and through the courtesy of Mr. J. F. Deems, the general superintendent of motive power of the road, we are able to give our readers some information concerning it.

of the rear drivers. The two low pressure cylinders are placed in the usual position outside the frames; their pistons apply force to the rear pair of drivers, in the usual way. The high pressure cylinders are placed between the frames, 46

promise, if one may say so, which takes into account the forward end of the side rod and the heavy connecting rod which is attached to the crank axle. This is clearly shown in the engraving.

The arrangement of the guide bars of the high pressure cylinders is novel. The guides and crossheads for all cylinders are alike, but the high pressure guides are bolted to the underside of the valve chamber of the low pressure cylinder. The crosshead is a modification of the Laird type, but is arranged so that the wearing surfaces are all enclosed and covered up so that they are thus kept free from dust and grit.

The boiler of this engine is a straight top one, the barrel measuring 70 $\frac{5}{8}$ ins. inside, at the smoke box end. The fire box is large, being 75 $\frac{1}{4}$ ins. across, 96 $\frac{1}{8}$ ins. long and 69 ins. deep at the back and coming down to 80 $\frac{3}{4}$ ins. in the front. There are two good 6 in. wash-out plugs in the bottom of the barrel, one close to the smoke box end and the other near the throat sheet. The smoke box, while of ample proportions, is not an extension box, but is what is called self cleaning. The heating surface is as follows: Tubes, 3,248.1 sq. ft.; water tubes for arch, 23 sq. ft.; fire box, 175 sq. ft.; total, 3,446.1 sq. ft. Grate area, 50.3 sq. ft. Some of the principal measurements are as follows:

General Dimensions—Weight in working order, 200,000 lbs.; weight on drivers, 110,000 lbs.; weight engine and tender in working order, 321,600 lbs.; wheel base, driving, 7 ft.; wheel base, rigid, 16 ft. 6 in.; wheel base, total, 27 ft., 6 in.; wheel base, total, engine and tender, 53 ft., 8 in.

Valves—Greatest travel of slide valves, 6 in.; outside lap of slide valves, 1 in.; inside clearance of slide valves, h.p. $\frac{1}{4}$ in., l.p. $\frac{3}{8}$ in.; lead of valves in full gear, $\frac{1}{4}$ in. lead forward motion when cutting off at 11 in. of the stroke.

Wheels, etc.—Dia. driv. wheels, 79 in.; diam. and length of driving journals, 10 in. dia. x 12 in.; diam. and length of main crank pin journals (back side, 6 $\frac{3}{4}$ in. x 4 in.), back, 6 in. dia. x 6 in.; diam. and length of side rod crank pin journals, front, 5 in. dia. x 3 $\frac{1}{4}$ in.

Boiler—Working pressure, 220 lbs.; thickness of plates in barrel and outside of fire box, $\frac{3}{8}$ in.,

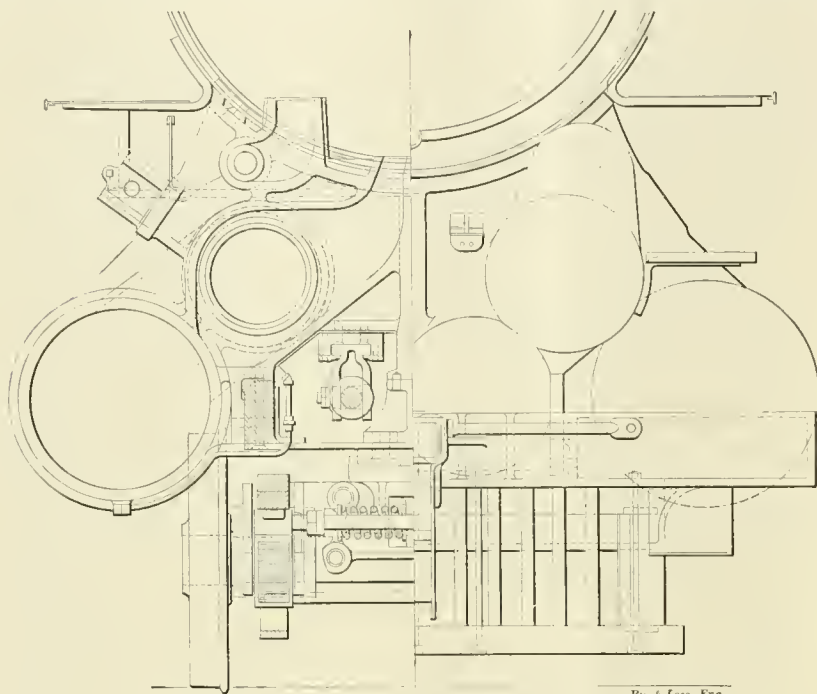

SECTION OF 4-CYLINDER COMPOUND, N. Y. C. & H. R. R.

It is an Atlantic or 4-4-2 passenger engine with cylinders 15 $\frac{1}{2}$ and 26x26 ins., and driving wheels 79 ins. in diameter. The calculated tractive effort is about 23,830 lbs. The valve gear is of the ordinary indirect type and the valves, of

ins. ahead of the low pressure cylinders, and their pistons drive on the forward or crank axle. These high pressure cylinders in fact lie out practically on the front foot plate.

The cranks and crank pins are arranged so as to make a perfect balance in the working parts. When the low pressure piston on the right side is at the front end of the cylinder, the high pressure piston on the same side is at the back end of its cylinder and the left main crank pin is on its bottom quarter

and the left crank on the forward axle is at its highest point. The counterbalancing of the wheels is interesting. The rear drivers are counterbalanced in the usual way, but the counterbalancing of the forward driving wheels is a com-

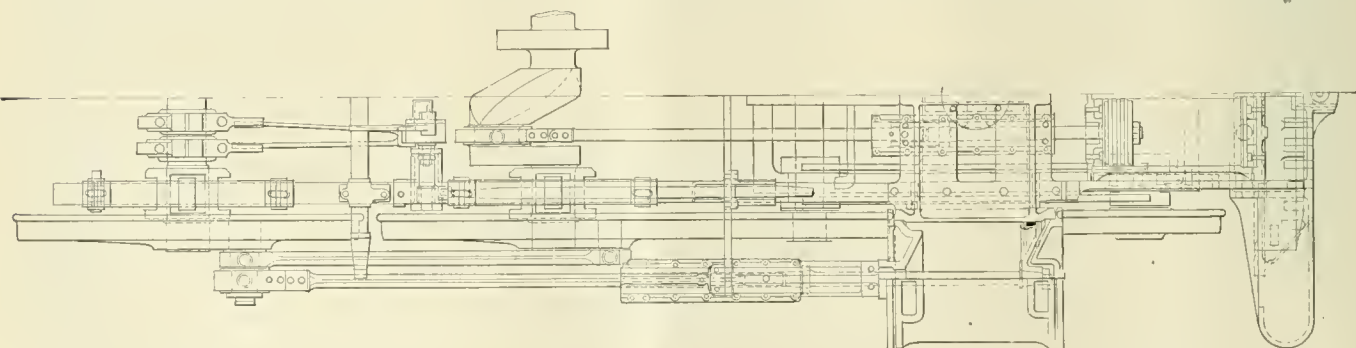

PLAN OF WHEEL AND CYLINDER ARRANGEMENT, 4-CYLINDER COMPOUND, N. Y. C. & H. R. R.

which there are four, one for each cylinder, are all outside admission piston valves. Two are on one stem on one side and two are on another stem on the other side, making a tandem arrangement. The eccentrics are on the axle

and the left crank on the forward axle is at its highest point. The counterbalancing of the wheels is interesting. The rear drivers are counterbalanced in the usual way, but the counterbalancing of the forward driving wheels is a com-

$\frac{5}{8}$ in., $\frac{5}{8}$ in.; fire box plates, thickness, sides, $\frac{5}{8}$ in.; back, $\frac{3}{8}$ in.; crown, $\frac{5}{8}$ in.; tube sheet, $\frac{1}{2}$ in.; fire box, water space, 4 and 5 ins.; front, 3 $\frac{1}{2}$ and 5 $\frac{1}{2}$ ins.; sides, 3 $\frac{1}{2}$ and 4 $\frac{1}{2}$ ins. back; tubes, number, 390; tubes, diam., 2 in.; tubes, length over tube sheets, 16 ft.

Tender—Style, V-shaped tank; weight, empty, 51,600 lbs.; wheel base, 16 ft. 9 $\frac{1}{2}$ in.; tender frame, 10 in. channels; water capacity, 6,000 U. S. gallons; coal capacity, 10 tons.

Exhibit of Sellers' New Planer.

On the invitation of William Sellers & Co., a party consisting of representatives of manufacturing establishments, engineers, business men and press representatives enjoyed the hospitality of the company on April 30 in connection with the exhibition of a variable speed planer which has been in process of development for some time, and which we expect to illustrate and describe in an early issue.

The exhibition was made on a Saturday afternoon when the shops were closed and the big planer became the conspicuous attraction. A fine luncheon was first served, after which Mr. Coleman Sellers, Jr., gave a very clear description of the machine by means of a large sectional drawing. After that the

theoretically and practically, the left driving wheel of a locomotive becomes deformed, and, consequently, all the locomotives running on the line have their tires deformed more or less. Now, the result of the flats produced is that the left wheel has a smaller circumference than the right. Consequently, if locomotives had an entirely free path, they would always go to the left; but the flanges of the wheels prevent this. The difference in the circumference of the driving wheels will thus either have the effect of exercising a forward thrust on the left rail or a backward one on the right. Now, the former is what actually occurs, and this is due to the fact that both rails tend to creep forward under the effect of the blows given by the wheels to the rail ends at the joints. Con-

sequently, the left rail creeps forward, and said that he was prepared to bet that he would recover the pince-nez from the bottom of the pool. His friends declared that this was an impossible feat, but Herbert Spencer still offered to make the bet. His challenge was accepted by one of the visitors. Upon the following evening Spencer returned to the house with the missing eyeglasses. He had fastened a strong magnet on the end of his fishing line, and fished for the glasses until it came into contact with their steel rims.—*M. A. P.*

Summer School.

The fourth annual session of the Summer School for Artisans held under the direction of the College of Engineering of the University of Wisconsin begins on

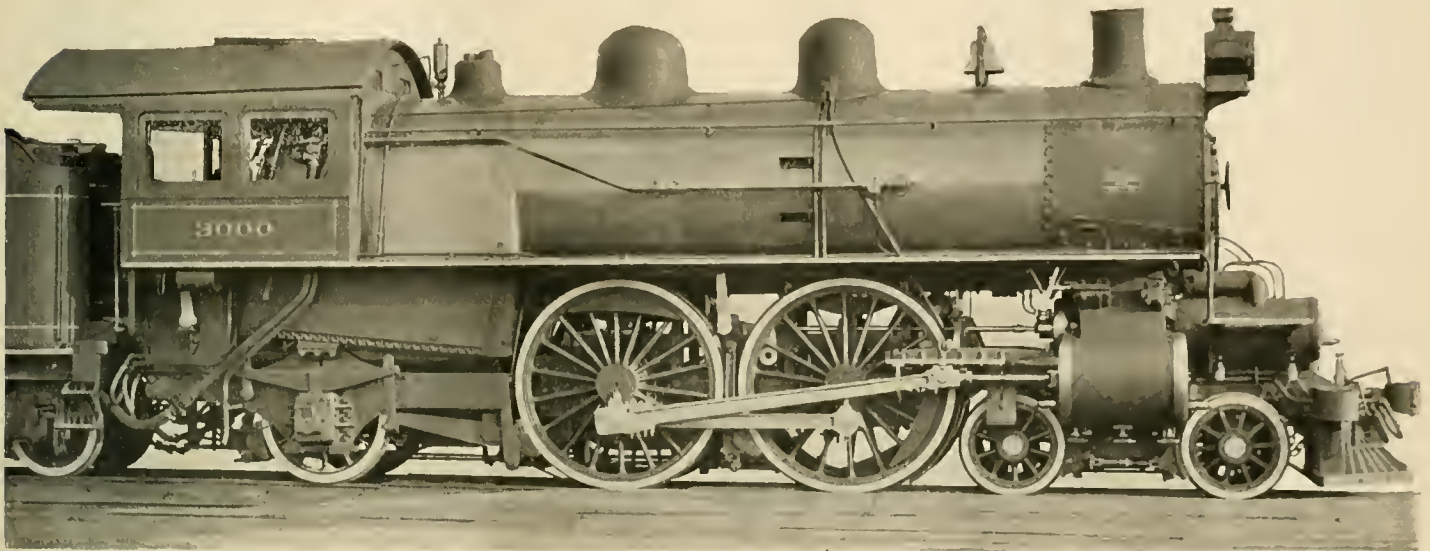

FOUR-CYLINDER, BALANCED, DIVIDED COMPOUND LOCOMOTIVE—44-2 TYPE.—NEW YORK CENTRAL & HUDSON RIVER RAILROAD.
J. F. Deems, General Superintendent Motive Power. American Locomotive Company, Schenectady Works, Builders.

machine was shown at work performing various cutting operations. It is 100x96 ins. with 20 ft. travel. The cutting speed is variable to suit the work to be done and the return speed is constant at 100 feet per minute. It was surprising how smoothly the heavy table came to rest after its rapid return journey. The visitors displayed keen interest in the performance of the planer and it moved the venerable John Fritz to some interesting reminiscences about the first planers he had used. Dr. Coleman Sellers and others talked about the pioneer machine tools they had known, which made the meeting a very interesting affair.

Creeping of Left Hand Rail.

There is a belief based on rather unsatisfactory data that the left hand rail on a double track creeps more than that on the right hand side. The following explanation of the phenomenon has been offered by Mr. O'Busse, of Copenhagen, and appears feasible: "As proved both

subsequently, it is easier for the left rail to go forward than for the right rail to go backward."

The explanation is feasible if the left hand wheels become distorted, as Mr. O'Busse says, but we are inclined to question the correctness of his statement. There has been considerable discussion in the pages of RAILWAY AND LOCOMOTIVE ENGINEERING about the uneven wear of locomotive tires, and we never heard that the left hand tire wore more rapidly than that on the right hand side. What do our readers think?

Applied Science.

A true story of Herbert Spencer—none the worse, perhaps, for being a little belated. He once won a curious wager. He was staying for a fishing holiday in the house of Sir. Francis Powell, the president of the Scottish Academy, and, while angling for trout, he happened to drop his eyeglasses into a deep pool of the river. In the evening he related his

misadventure to his host and the guests, and said that he was prepared to bet that he would recover the pince-nez from the bottom of the pool. His friends declared that this was an impossible feat, but Herbert Spencer still offered to make the bet. His challenge was accepted by one of the visitors. Upon the following evening Spencer returned to the house with the missing eyeglasses. He had fastened a strong magnet on the end of his fishing line, and fished for the glasses until it came into contact with their steel rims.—*M. A. P.*

This is an excellent course for workmen desirous of acquiring scientific knowledge concerning their business. The leading purpose of this school is to supplement the work of correspondence schools by extending to students facilities for laboratory experiments and shop practice.

The course lasts six weeks and all the living expenses and school fees is only about fifty dollars.

The gross earnings of the Chicago Great Western Railway often called the Maple Leaf Route, for the second week of April, 1904, shows an increase of \$8,107.47 over the corresponding week of last year. Total increase from the beginning of the fiscal year \$536,096.25.

Designing of Locomotive Boilers.

BY ROGER ATKINSON.

(Continued from page 201.)

RIVETED JOINTS.

All these types of "lap" joints, however, have nearly all gone out of use for locomotive boilers on account of the liability to serious damage by "grooving" or corrosion along the inside of the plate near the edge of the seam, thus, at A, in Fig. 7. This is due to the lap joint not making a perfectly circular seam, and the strain not being direct, the seam tries to take the form shown in Fig. 8, and the plate is strained at A, which causes corrosion to take place rapidly. It is, therefore, usual to adopt the butt joint with double welts.

These are constructed in different forms, such as the single riveted joints, Fig. 9, or the zigzag double riveted thus, Fig. 10, the strength of these being calculated as for the lap joint except that the rivets are in double shear, and in cal-

culating rivet strength in double shear we do not allow full strength for each shear, but only $1\frac{3}{4}$ for the two faces of the plate. Butt welts must be not less than $\frac{5}{8}$ the thickness of the barrel plate, but are quite frequently made the same thickness. Other seams of higher efficiency are in common use, for instance, the double welted, triple riveted seam used in high pressure boilers, which is made as in Fig 11. The only place at which this seam can tear the plate is along the row A B, which would leave the inside welt fast to the other piece of plate. This row of rivets is called the safety row, as the rivets are much further apart than in the seam proper. At the same time the caulking edge is along the

student should practice the application of the principles already shown to a joint of this kind at the point of failure indicated. The rivets in the outer row are usually about $5\frac{1}{2}$ ins. apart and should never exceed $8\frac{1}{2}$ ins.

When it is desired to calculate the

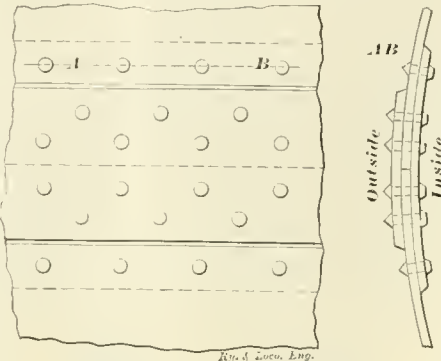

FIG. 11.

strength of the circular seam of a boiler we take the circumference of the boiler on the center line of plate, deducting all the rivet holes, then multiply by the thickness of the plate. For example, suppose, in the former case, the boiler is 50 ins. inside diameter by $\frac{1}{2}$ in. thick, the mean diameter of plate is $50\frac{1}{2}$ ins. and the circumference is 158.7 ins. Allowing 70 rivets at about $2\frac{1}{4}$ in. pitch and $\frac{7}{8}$ in. diameter, we have $(158.7 - .875 \times 70) \times \frac{1}{2} = 48.72$ sq. ins. of plate at 60,000 lbs. = 2,923,200 lbs. strength; as the area of the boiler is 1,963.5 sq. ins., we have $1,963.5 \times 150 = 292,320$

294,525 lbs. strain, or $\frac{294,525}{2,923,200} = 9.92$

factor of safety of plate. For the rivets we have area $.6013 \times 70 \times 48,000$ lbs. = 2,020,368 strength, and $\frac{2,020,368}{294,525}$

= 6.86 factor of safety for rivets. These are for single riveting, but we generally double rivet the circular seams for tightness, and to give the boiler strength as a beam or tubular girder to withstand vibration. It should be noted

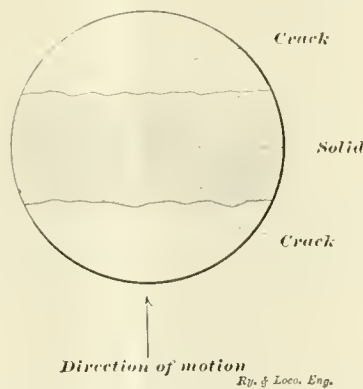

FIG. 12. MAGNIFIED STAY BOLT SHOWING CRACKED AREA.

that while the joint is the weakest part of a boiler barrel when the boiler is new, being only a fraction or percentage of the solid plate, this condition does not continue to exist unaltered, since the longer the boiler is in service the plates deteriorate more than the joint, and, consequently, a time comes when the joint may be equal in strength to the plate. Up to this time the boiler shell is fit to carry the full working pressure for which it was first designed, but when the plate becomes still weaker it must be replaced or reinforced if the full pressure is to be carried.

HOLES IN BARREL—STAYS AND BRACES.

In the best practice all holes cut in the plate should be reinforced by welts which furnish an equal amount of strength to that removed in the hole, and thus all check valve holes, etc., should have liners riveted on, and in particular the dome base must either

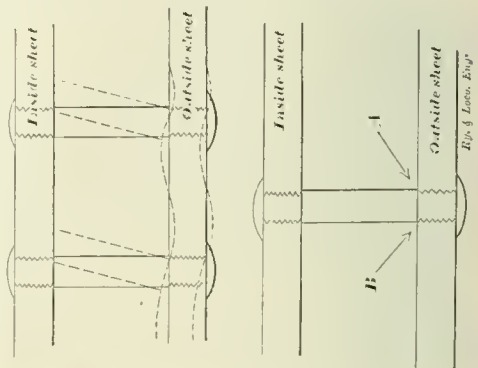

FIG. 13.

FIG. 14.

be made of plate heavy enough to make up the deficiency, or an additional liner must be riveted on.

In arranging for fire box stays it is usual to adopt a spacing of 4 ins. apart both vertically and horizontally, or as near this as possible, so that the area carried by each staybolt is between 17 sq. ins. and 15 sq. ins. or less.

The working pressure for flat surfaces supported by screw stays may be found by the following formula:

$$\frac{C \times (T + 1)^2}{S - 6} = \text{working pressure.}$$

S—6

Where T = the thickness of the plate in $\frac{1}{16}$ of an inch, in this case 5 for $\frac{5}{16}$ plate.

S = surface in square inches, 16.

C = Constant = 60 for plates having water on one side and exposed to fire on the other. Then $(T + 1)^2 = (5 + 1)^2 = 36$ and

$$\frac{60 \times 36}{16 - 6} = \frac{2160}{10} = 216.$$

Thus, for a fire box having $\frac{5}{16}$ in. side sheets, we get $\frac{216}{16 - 6} = 216$ lbs. The strain upon the staybolt is

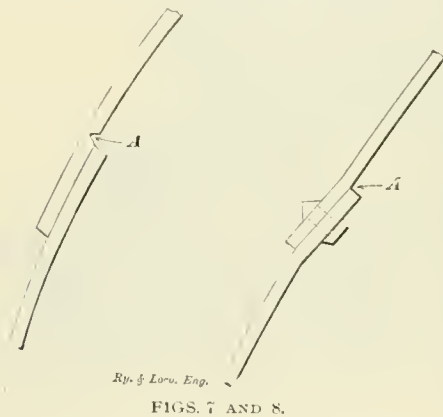

FIGS. 7 AND 8.

culating rivet strength in double shear we do not allow full strength for each shear, but only $1\frac{3}{4}$ for the two faces of the plate. Butt welts must be not less than $\frac{5}{8}$ the thickness of the barrel plate, but are quite frequently made the same thickness. Other seams of higher efficiency are in common use, for instance, the double welted, triple riveted seam used in high pressure boilers, which is made as in Fig 11. The only place at which this seam can tear the plate is along the row A B, which would leave the inside welt fast to the other piece of plate. This row of rivets is called the safety row, as the rivets are much further apart than in the seam proper. At the same time the caulking edge is along the



FIGS. 9 AND 10.

edge of the outside welt, where the rivets are comparatively close together, and do not allow the plate to spring up when caulked. Seams of this kind are commonly designed with an efficiency equal to 87 per cent. of the solid plate. The

generally limited to 7,000 lbs. per sq. in. of section at bottom of thread.

FAILURE OF STAYBOLTS.

It is always found that staybolts fail by cracking at the inside of the outer sheet, due to flexure or bending by the expansion and contraction of the inside fire box, which being secured to the mud ring, which is stationary, expands upwards and contracts downward, and also stretches and contracts forward and backward. The staybolts crack above and below, as shown in Fig. 12, at right angles to the direction of motion of the box. This cracking is due to the crushing of the fiber during compression and consequent loss of cohesion during extension. This will be better understood by Fig. 13. The full lines show the relative positions of inside and outside plates when cold, but when the inside plate is lifted by expansion the staybolts exert a pressure tending to bend the outside plate as shown in dotted lines. If the plate is not thin enough to yield in this way then the staybolt has to make up the difference by bending, see Fig. 14, causing compression of the fibers at "A" on the top, and extension below at "B." The box is hot for a comparatively long period of time, and the stay bolt has time to take a bent form, so that when the box is eventually cooled and contracts, the staybolt probably does not return to the original straight position, but undergoes some extension above and compression below. This extension at "A" causes an incipient crack which soon develops by repetition into a broken bolt. Thus the more rigidly staybolts are held by the outer shell, the more staybolts will be broken.

There is a great increase in the number of staybolt failures when a 1/2 in. plate is used for the outer shell as compared with a 7/16 in. plate, especially if the box is deep. This is due to the 7/16 in. plate yielding to the bolts to a greater extent than the 1/2 in. plate yields. This is a strong argument against the use of a single plate for the complete outside shell which is frequently done, as the top or roof sheet requires a plate thicker than 7/16 in. in order to make provision for boiler mountings, pop valve stands, etc. The only point in favor of the single sheet casing is that longitudinal seams are avoided, but it is at enormous expense in broken stay bolts and consequent detention and loss of service. A similar result in broken staybolts may be noticed where the outer plate is stiffened by a doubling plate, or where it is thick and short as in the throat sheet, etc. From these results it is evident that in arranging staybolts it is important that absolute rigidity should be avoided, as it is in all boiler designing where expansion may produce defects.

Thus it is advisable to keep the side rows well away from the flanges of the tube and back sheets, or about 3 3/4 ins. from the center of the rivets in the flange, thus, Fig. 15, and also from the root of the curve of the flange.

Braces which support the flue sheet below the tubes and above the throat sheet staybolts should be made without a weld, and sufficiently light in the body to allow some slight flexibility. The best and most efficient system of staying the back head above the fire box and the front flue sheet above the flues is by a system of gussets; these are not required to be flexible, not being subject to expansion, but it is important that the angles should be of steel, as iron angles easily corrode away in the corner. The common

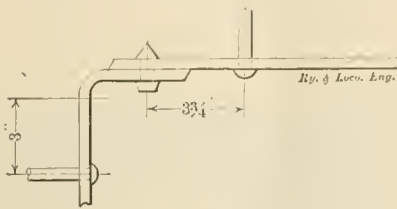

FIG. 15.

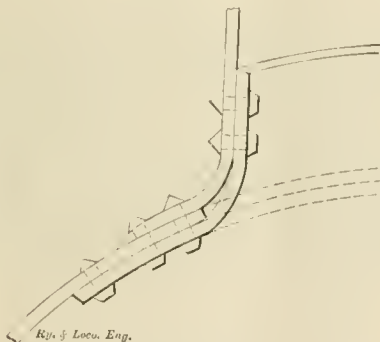

FIG. 16.

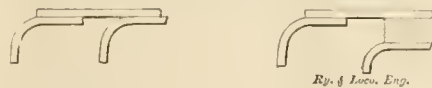

FIG. 17.

method of supporting these boiler heads is by rod stays with welded jaws connected to angles on the plates with pins and is very liable to be defective by reason of bad work, or by the pins being accidentally omitted. In some cases the pins become so badly worn by the rods being loose that they are eventually cut off and fall down, when they cannot be replaced without removing the stays.

The dome is, in recent practice, usually connected to the barrel by a heavy flanged base, made of 1 1/4 in. plate, which is turned inside to receive the dome barrel and shrunk on hot, the barrel having a welded joint. The hole in the boiler barrel is made as small as possible, just sufficiently large for the

standpipe and for a slight man to pass through. This makes a firm connection, but it introduces a spot having extreme rigidity, "like a tin patch on a cotton shirt," as one designer has aptly expressed it. A better connection can be made by flanging the dome shell to the barrel and supporting it by an inside plate flanged up into and riveted to, the dome, see Fig. 16. The edge of the dome is then the caulking edge and the liner is riveted with a safety row along the outside edge. This design allows the full diameter of the dome for access to the boiler.

One of the troublesome points in many boilers is to get tight corners. This is not difficult to overcome if the corner is made with sufficient care. In the first place it is usual to make the mud ring in the smith's shop and without any finishing, to drill it and fit the plates to it by heating, trusting to "luck" to get them all bedded. It is somewhat expensive in first cost to machine the ring, but it is expense well bestowed to finish it by machining all round inside and outside. If this is done and the plates well scarfed, with a long scarf, equal in length to 10 times the thickness of the plate, there is not the slightest difficulty in getting absolutely tight corners. It is advisable but not necessary to double rivet the corners.

Another point which gives continual trouble is the fire hole. Many designs have been employed but all fail in service by cracking, apparently due to rigidity. One of the best designs is to flange both the inside and outside sheets outward and connect them with a welded sleeve, as in Fig. 17. This design also is subject to trouble from cracking, but not to an excessive degree, and has the merit of being easy to repair. On some roads a modification of this design has been used, but the writer has not had any experience with it. It is constructed with a forged ring, Fig. 16, and appears to facilitate repair, but not to avoid failure by cracking of the inside sheet, unless the increased body of water may have some effect.

In conclusion it is advisable to caulk all boilers thoroughly internally as well as externally as a very efficient method of reducing liability to leak.

Valve Motion Model.

Our valve motion model is 29 ins. long over all, and stands 11 ins. high. The cylinder is 3 1/4 ins. in diameter by 4 1/2 ins. stroke. The throw of the eccentrics is 1 in. and the length of the link slot is 4 3/4 ins. The model is, therefore, large enough to work with, comfortably, without it being unwieldy, and the effects of the various changes which can be made in the valve gear are readily apparent.

Vanderbilt Steel Flat Car.

The new design of steel flat car illustrated here, will appear to some people as merely the substitution of commercial shapes for old time wood construction. Although this may be the case, it will be found that the various members have been selected with the purpose of providing the proper sectional area in each case, and not wasting the metal. The 100,000 lbs. capacity car shown here weighs 2,865 lbs., and was designed to carry a uniformly distributed load of 100,000 lbs. between bolsters, or a concentrated, load of 50,000 lbs. between needle beams.

The car is cheaper to build than any steel flat car now on the market, and as commercial shapes are used throughout, repairs can readily be made in any car shop and at minimum cost. The workmanship on these cars, which were built by the South Baltimore Steel Car and

Low Service Compressors for Air and Carbonic Acid Gas.

The 12-page pamphlet published by the Laidlaw-Dunn-Gordon Company, of 114 Liberty street, New York City, describes compressors intended for pressure of 30 pounds and under. These compressors are built with open suction for supplying air at low-pressure, or with closed suction for handling carbonic acid and other gasses. The inlet valves are of the semi-rotary type, while the outlet valves are of the poppet type. Rotary valves are considered superior for inlet service, not only because of their greater efficiency and durability, but furthermore because they open promptly and offer no resistance to the incoming air, which the poppet valve, held down by a spring, must necessarily do, thus cutting down the volume capacity of the compressor. The discharge valves, on the other hand, present a dif-

very different to what it is now are of course to be found in this digest, but obsolete cases or those which could not be used as precedents are abbreviated and so worded as to prevent their being mistaken as applicable to present day conditions.

There are printed on the concluding pages a list of the values of car bodies and car trucks, also a table of the depreciated value of \$100 at six per cent. for every month of fourteen years. In order to ascertain the depreciated value of a car it is only necessary to multiply the amount shown in the table for the age of the car by the original value of the car and point off four places of decimals. The limits of tire wear for the various types of steel tired wheels are graphically shown in a series of line cut illustrations. Some useful data is also given with some hints on first aid to the injured. The M. C. B. unfair usage rule in tabular form

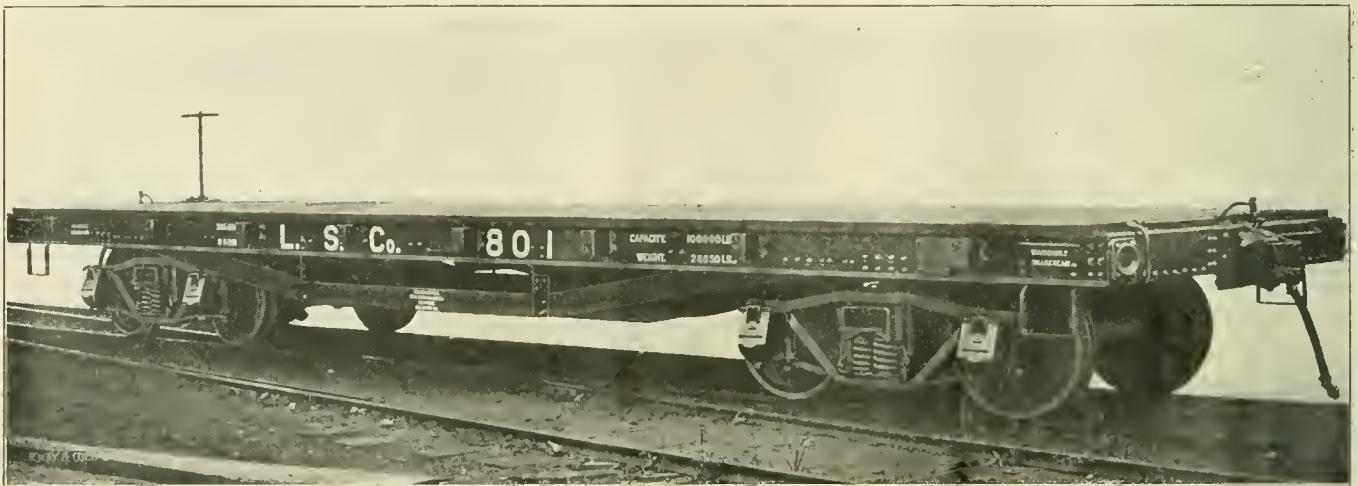

VANDERBILT FLAT CAR, MADE OF STRUCTURAL SHAPE.

Foundry Co., is very much above the average quality turned out by most car builders.

The first cars of this design were built in 1902, and immediately placed in service by the Lackawanna Steel Company, who used them as crane cars. The results of this arrangement were so satisfactory that a duplicate order was given. The cars measure 35 ft. 6 ins. long and 9 ft. 2 ins. wide. The equipment consists of Tower M. C. B. couplers 5x7 ins. shank; N. Y. Air Brakes; Sessions' Standard Friction Draft Gear type "C;" Atha cast steel bolsters designed by L. A. Shepard, general sales agent; Buffalo Brake Beams; Brasses and Grey Iron Journal Boxes made by the car builders.

We are allowed to reproduce drawings and photographs by courtesy of the builders, whose New York representative, Louis A. Shepard, supervised the designing and construction of the cars for Mr. Cornelius Vanderbilt, the patentee.

ferent problem owing to the fact that the point of opening should vary with variations in pressure, and the poppet type has been adopted for this service. The pamphlet will be sent by the company issuing it to anyone who is interested enough to apply to them for it.

The Car Interchange Manual.

The Car Interchange Manual, compiled by Mr. J. D. McAlpine, of the Lake Shore, is a neat little book, pocket size, which has come to us with the compliments of the McConway & Torley Company, of Pittsburgh, Pa. This 1904 edition is a compendium of useful information for master car builders, car inspectors and others interested in car interchange.

The manual contains a complete index of the decisions of the M. C. B. Arbitration Committee from 1 to 667, and also a condensed statement of each case with decision. Cases which were decided when the code of interchange rules was

and a condensed abstract and index of the arbitration committee's decisions also appear.

The book is complete in its way and will be found most useful to those connected with car interchange.

High Price of Power at St. Louis.

We have heard some of our manufacturing friends talking very hotly about the charge for power to be imposed upon exhibitors at the St. Louis Exposition. The charge decided upon is ten dollars per horse power a month. Several concerns that manufacture railroad appliances became doubtful about the likelihood of an exhibit at St. Louis proving a paying investment. When the exhibition authorities decided on charging the high price for power the doubtful ones decided to keep away.

It is a pity that anything should have been thrown in the way to discourage exhibitors, for it tends to reduce the patronage which may not be so large as might be desired.

Of Personal Interest.

Mr. T. J. Cole, acting master mechanic at Meadville, Pa., on the Erie Railroad, has been appointed master mechanic.

Mr. T. Rumney has been appointed assistant mechanical superintendent of the Erie Railroad, with office at Meadville, Pa.

Mr. J. Wolfenden has been appointed general foreman boilermaker on the Erie Railroad with office at Meadville, Pa.

Mr. H. B. Hunt has been appointed assistant mechanical superintendent of the Erie Railroad, with office at Meadville, Pa.

Mr. J. J. Dewey, acting master mechanic at Galion, Ohio, has been appointed master mechanic on the Erie Railroad.

Mr. W. Miller has been appointed master mechanic of the Terminal Railroad Association of St. Louis, with office at St. Louis, Mo.

Mr. W. S. Brazier has been promoted to the position of traveling engineer on the Boston & Albany Railroad, with headquarters at Mechanisville, N. Y.

Mr. William F. Tye has been appointed Chief Engineer on the Canadian Pacific, vice Mr. E. H. McHenry, resigned. Mr. Tye's office will be at Montreal.

Mr. Eugene M. Kann has been appointed acting general foreman of the Wabash Railroad, with office at Delray, Mich., in place of Mr. J. M. Barnes.

Mr. J. F. Blackman has been appointed general foreman of the Chattanooga, Tenn., shops of the Central of Georgia, vice Mr. R. L. Doolittle, transferred.

Mr. John Cardell has been promoted to the position of master mechanic on the Canadian Pacific Railway, with headquarters at Winnipeg, Man., Canada.

Mr. G. W. Bynow has been appointed general foreman of the Scranton shops of the Delaware, Lackawanna & Western, vice Mr. H. Shoemaker, promoted.

Mr. Wm. Schlafge has been appointed master mechanic of the New York Division of the Erie, with office at Jersey City, N. J., vice Mr. T. Rumney, promoted.

Mr. J. J. Curtis, master mechanic on the Chicago & Eastern Illinois at Danville, Ill., has been transferred as master mechanic by the same company to Villa Grove, Ill. The shops at that point will shortly be completed and Mr. Curtis will have charge of the St. Louis new line equipment.

Mr. Edward F. Leonard has been appointed master mechanic on the Maricopa & Phoenix and Salt Valley Railroad, with headquarters at Phoenix, Ariz. Ter., vice Mr. J. Kenedy, resigned.

Mr. F. D. Underwood.

Mr. F. D. Underwood, president of the Erie Railroad, has just returned from a visit to Europe, which was enjoyed, for the sake of a brief rest. While the visit was not for business Mr. Underwood devoted considerable attention to railway matters on the other side, more particularly to their methods of handling passenger business, and he says that we might learn a good deal from English practices.

We present a picture of Mr. Under-



MR. F. D. UNDERWOOD.

wood because he is a man whose career ought to stimulate the thousands of our readers, especially the young ones who are ambitious to succeed in railroad life. Mr. Underwood when a young man, left a position as clerk paying \$1,000 a year, to accept a job as brakeman at \$50. Even that did not hold, for the wages of brakemen were shortly afterwards reduced to \$45 a month, which made a little more "pinching down." Speaking of the experience, Mr. Underwood said: "I can remember now how blue I felt and how I was for the time convinced that I had made a mistake, but I was a little too 'game' to say so and I could not go back upon myself. In this connection I might mention that one of my old office associates, now over seventy years of age, is still in the same position, receiving about \$50 per month."

Mr. S. E. Kildoyle has been promoted by the Southern Pacific to the position of master mechanic at Guaymax, Mexico, on the Sonora Railway, vice Mr. R. A. Johnson, transferred.

Mr. A. Beckert, formerly general master mechanic of the Louisville & Nashville Railroad at Decatur, Ala., has resigned his position. He will live at Dayton, O.

Mr. W. H. Hudson, heretofore master mechanic, has been appointed general master mechanic of the Southern Railway. His headquarters are in Birmingham, Ala.

Mr. Theron F. De Garmo has been appointed western representative of the Flannery Bolt Company, with office in Chicago. This company handles the Tate flexible stay bolt.

Mr. W. J. Buchanan has been appointed master car builder of the Bessemer & Lake Erie Railroad. He will report to, and receive his instructions from, the superintendent of motive power.

Mr. W. E. Chester, formerly general foreman of the Macon, Tenn., shops of the Central of Georgia, has been appointed general master mechanic of the company, with headquarters at Savannah, Ga.

Mr. A. Stewart, formerly general master mechanic, has been appointed mechanical superintendent of the Southern Railway, succeeding Mr. S. Higgins. Mr. Stewart's office will be in Washington, D. C.

Mr. M. R. Coutant has resigned his position as master mechanic on the Erie Railroad at Susquehanna, Pa., to accept that of master mechanic of the Ulster & Delaware Railroad, with headquarters at Rondout, N. Y.

Mr. H. L. McLow, formerly master mechanic of the El Paso & Northeastern at Santa Rosa, Tex., has been appointed assistant superintendent of motive power of the same road, with office at A'mogordo, N. M.

Mr. W. H. Fetner, who has been general foreman on the Central of Georgia at Macon, Ga., has been appointed master mechanic on the same road, with headquarters at Macon, Ga., vice Mr. W. E. Chester, promoted.

Mr. S. T. Park, formerly master mechanic on the Illinois Central Railroad at Centralia, Ill., has accepted the position of master mechanic on the Chicago & Eastern Illinois at Danville, Ill., vice Mr. J. J. Curtis, transferred.

Mr. George J. Gould.

President George J. Gould, of the Missouri Pacific, the Wabash, and other companies, has been prominently in the public eye lately through the successful efforts he is making to establish a new transcontinental line in connection with the Missouri Pacific lines.

Mr. Gould is one of our capitalists who came into railroad business from the top without personal effort, but we believe that he possesses the characteristics which would have achieved great success had his own unaided efforts been left to work out the problem of his career. From the first Mr. Gould was ready to work through the drudgery of office work in learning the details of railroad business. On becoming the head of the family, Mr. Gould assumed the management of the vast railroad interests left by his father and his policy as a manager has always been to pursue the fair dealing with employees which has always characterized the Gould lines. We take the opportunity to present the portrait of Mr. George J. Gould to enable the hundreds of readers we have on the Gould lines to acquaint them with the looks of the man who exercises so much influence over their destinies.



MR. GEORGE J. GOULD.

Mr. Arthur Warren has been engaged by the Allis-Chalmers Company, as they have found it desirable to create a Department of Publicity. They have been fortunate enough to secure the services of a gentleman whose work in the field of technical journalism and whose success as what one may perhaps call a "publicity promoter" is well known in the industrial field. Mr. Warren is a Bostonian with remarkable qualifications for the work to which he has devoted himself.

Mr. James White.

The annexed photograph is the likeness of Mr. James White, now retired, and one of the oldest veterans of the Pennsylvania Railroad Company, from whom we have received some valuable historical data concerning the Camden & Amboy Railroad.

When Mr. White retired, in January, 1900, it was in obedience to the rules of



MR. JAMES WHITE.

the pension department of the road and not because of infirmity. At that time he had been 54 years in the employ of the Camden & Amboy road, or the section of the great Pennsylvania system bearing that name. In all that time he never had or caused an accident, nor was he ever called in and reprimanded. Such a record is in itself remarkable.

In 1846 that Mr. White entered the Camden & Amboy employ as a brakeman. Two years later he was made a conductor, and in 1850 he went on an engine as fireman. He served in that capacity three years and was then given an engine. The first engine he ran was the old "John Bull," now and for a long time in the Smithsonian Institute, at Washington.

For 38 years, or until 1891, he was an engine runner. In that year he was made roundhouse foreman, and for eight years he served the company in that capacity. In May, 1899, he again went on an engine. He ran a drill engine in the yard until the time of his retirement, in January, 1900. When reference was made to his age, Mr. White said that he was 17 years old

when he began railroading. A little mathematics, after reference to some of the foregoing dates, will give his age at the present time.

During the World's Fair, at Chicago, Mr. White ran Old John Bull, which was taken from the Institute and included in the railroad company's exhibit at the great fair. It was a memorable experience. Mr. White has other claims to fame. In 1854 he was engineer on the first owl train out of Philadelphia, and for a time he carried the belated pleasure seekers from the Quaker City as far away as Trenton. He was one of the organizers and charter members of the Brotherhood of Locomotive Engineers.

The Passing of a Pioneer.

In the death of Peter Petrie, on April 9, at Detroit, Mich., at the ripe age of 78 years, there was severed a connecting link between the first railroad in this country and those of to-day, he having begun his railroad career on the Mohawk & Hudson, as fireman, and shortly thereafter, in 1848, went to the Michigan Central, which was then equipped with strap rails and only extended from Detroit to Kalamazoo, beginning on that road as an engineer, and remaining there in that capacity, with the exception of a few years on the Lake Shore and the



PETER PETRIE.

C., B. & Q., until his retirement a few years ago. He was one of the devoted band who organized the Brotherhood of the Footboard, and was also one of those who were marked and suffered for their zeal in promoting the interests of that organization. His record as an engineer was without a blemish—absolutely temperate, for he never tasted liquor in his long life, and was devoted to his work. He deserved the name of a safe engineer, as he never had a serious accident in his service of 60 years. Living a well ordered life, he retired a few years ago

well fixed in this world's goods, and the end came to the old man as peacefully as was his life, surrounded by his devoted daughter and grandchildren. The memory of "Pete" Petric will be green a good while to many men whom he had befriended, for his greatest pleasure in this life was to help those less fortunate than himself.

Mr. Fred Wells, formerly in the employ of the American Locomotive Company, at Manchester, N. H., has resigned his position in order to become general foreman for the D., L. & W. R. R. at Buffalo, N. Y.

Mr. J. W. Small, formerly master mechanic of the Tucson Division of the Southern Pacific, at Tucson, Ariz., has been transferred to a similar position on the same road at Los Angeles, Cal., vice Mr. R. S. Goble, assigned to other duties.

Mr. H. I. McMinn has been appointed agent and storekeeper of the Safety Car Heating & Lighting Co., in charge of storehouse and real estate in Jersey City, vice Mr. James N. Andrews, resigned. Mr. McMinn will receive and ship all materials on instructions from the second vice-president and will inspect and test all material to approved standards. The office of this company is at 150 Broadway, New York city.

Mr. C. L. Pasho has been appointed Assistant Superintendent of the Bessemer & Lake Erie Railroad. He will report to, and receive his instructions from, the superintendent, and in the absence of the latter, will act in his stead and report to the general manager.

Mr. R. J. Goodale, formerly roundhouse foreman at the Twenty-seventh street shop of the Illinois Central, has been appointed master mechanic of the Champaign & Centralia district of the same road, with headquarters at Centralia, Ill., vice Mr. S. T. Park, resigned.

Mr. R. L. Doolittle, assistant master mechanic at Chattanooga, Tenn., on the Central of Georgia, has been transferred to the Macon, Ga., shops of the same company, as general foreman, vice Mr. W. H. Fetner, promoted.

Mr. R. A. Johnson, master mechanic and master car builder of the Sonora Railway at Guaymas, Mex., has been transferred as master mechanic on the Southern Pacific to Tucson, Ariz., vice Mr. J. W. Small, transferred.

Mr. W. S. Morris, who not long ago retired from the position of mechanical superintendent of the Erie Railroad, was recently presented with a steel frame leather covered easy chair. He was at the same time also made the recipient of a large hall clock of beautiful design, both these gifts being marks of affection by the employees of the road. Mr. Mor-

ris replied suitably, and a pleasant evening was spent at his house.

Mr. Julius Kruttschnitt.

Mr. Julius Kruttschnitt, whose portrait we here reproduce, has been appointed director of maintenance and operation of the Harriman lines with headquarters at Chicago, Ill. The Harriman railway group embraces the Southern Pacific, the Union Pacific, the Oregon Short

Antonio Railway and of the Texas & New Orleans Railroad. In 1895 he became general manager of all the Southern Pacific lines.

Mr. H. V. Croll, who has been in charge of the Salt Lake City, Utah, office of the Allis-Chalmers Company for several years, and who was before that the representative of the E. P. Allis Company at Spokane, Washington, has



MR. JULIUS KRUTTSCHNITT.

Line, the Oregon Railroad & Navigation Company and the Leavenworth, Kansas & Western Railway. Mr. Kruttschnitt is a native of New Orleans and graduated as a civil engineer from the Engineering School of Washington and the Lee University of Lexington, Va. He entered railway service in 1878 and has been connected with Morgan's Louisiana & Texas Railroad and Steamship Company in various capacities and rose to be chief engineer and superintendent in 1883. He was at one time assistant manager of the Atlantic system of the Southern Pacific Company. In 1889 he became vice-president of the Galveston, Harrisburg & San

Francisco, Texas & New Orleans Railroad. In 1895 he became general manager of all the Southern Pacific lines. Mr. Croll's San Francisco office is 623 Hayward Building.

Mr. Howard D. Taylor has been appointed superintendent of motive power and rolling equipment of the Philadelphia & Reading, with headquarters at Reading, Pa., vice Mr. S. F. Prince, Jr., resigned. Mr. Taylor was born in Philadelphia and entered upon mechanical engineering work at the Baldwin Locomotive Works in that city. He was connected with Neilson & Co., of Glas-

gow, for a short time. On returning to the United States he spent some time in the employ of the Schenectady Locomotive Works and was subsequently employed at the Cooke Locomotive Works. In 1892 he became engineer of tests for the Erie and in 1894 he held a similar position on the Lehigh Valley. He held the position of mechanical engineer, subsequently master mechanic on the Erie. In 1899 he became connected with the Calumet & Hecla Mining Co., of Calumet, Mich. Within a couple of years he returned to the Lehigh Valley as superintendent of motive power, which position he has resigned to accept service with the Philadelphia & Reading.

OBITUARY.

Mr. J. M. Barr, at one time mechanical superintendent of the Erie Railroad, died recently at his home in Libertyville, near Chicago. He had been in failing health for some time previous, and hoping to regain his health he made an extensive trip through the country. He died at the age of 50 and is survived by a wife and two sons.

James A. Hinson, president of the National Car Coupler Company, and one of the best known inventors of car coupling devices in the country, died very suddenly of appendicitis at his home in Chicago. Mr. Hinson was fifty-two years old. Some of his most important inventions were an emergency knuckle, friction buffers and a new design of draw gear rigging.

After most of the paper has gone through the press, the melancholy news reaches us that our old friend, T. S. Ingraham, had died suddenly while sitting in his room at Los Angeles, Cal., where the Brotherhood of Locomotive Engineers are holding their biennial convention. Brother Ingraham was first grand engineer and was treasurer of the organization, and has been a grand officer about twenty-five years. He was a highly efficiently business officer and a genuine true-hearted man. He is the third grand officer suddenly called away since last convention.

We are shocked to learn that Samuel R. Callaway, president of the American Locomotive Company, died this morning (June 1) through the result of a surgical operation. Mr. Callaway was born at Toronto, Canada, in 1850, and entered railway service when thirteen years old. He rose through various grades to be president of the New York Central Railroad, which he left in 1900 to become president of the American Locomotive Company. The marvelous success of this organization has been in a great measure due to Mr. Callaway's able management.

Taylor-Newbold Cold Metal Saw.

A very efficient cold metal saw has just been put upon the market by the Tabor Manufacturing Company, of Philadelphia. The saw tooth is the invention of Messrs. Fred W. Taylor and Sidney Newbold. Mr. Taylor is known

in connection with the Taylor-White process of treating tool steel. The saw blade is of ordinary shape and may be made out of steel or iron as is desired. The teeth, however, are fitted in recesses, adjusted for height, and maintained in position by a key driven in at the back. The actual cutting tool is made of Burgess steel treated by the Taylor-White process. This cutting tool is imbedded in a socket, and an alloy of hard zinc is run around the tool steel so that it and the socket to all intents and purposes become one piece. At the bottom of the socket there is a set screw which, according as it is screwed in or out of the socket, regulates the height of the cutting edge of the tool above the saw blade.

The recess cut in the saw blade is grooved on each edge and a corresponding projection in the socket, engages with it. Back of the socket a key sim-

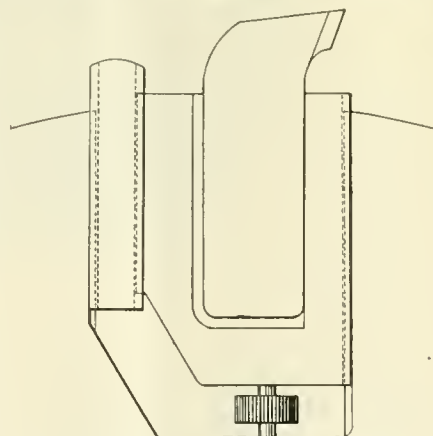
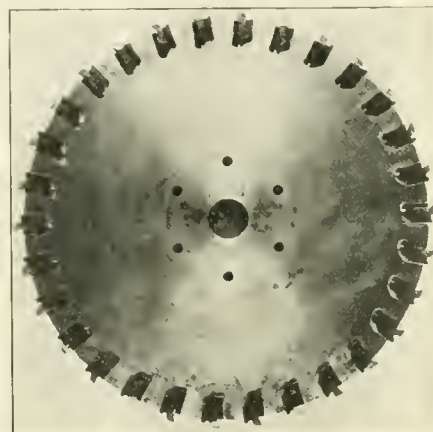

TAYLOR-NEWBOLD COLD METAL SAW.

ilarly ribbed engages with recess and socket and when driven home holds the latter firmly in place. Our illustration shows the relative position of saw blade, socket, cutting tool and key. The recess cut in the saw blade is so arranged that by no possible combination of circumstances can a saw tooth be put in wrongly. The recess has a sloping corner on the back side with which the adjusting set screw would interfere if the saw tooth were turned face backward. It

would also similarly interfere even if the saw tooth were turned in the right direction should an attempt be made to drive the key in, in front. The saw which was shown in operation to RAILWAY AND LOCOMOTIVE ENGINEERING was engaged in cutting a heavy steel forging having .35 carbon. A cut measuring 9 ins. wide by 14 ins. deep was driven through this steel by the Taylor-Newbold saw in twenty minutes, the kerf measuring $\frac{5}{8}$ in. and the chips coming away in heavy, hot, blue crisps of steel. It is estimated that an ordinary cold saw would have occupied four hours' time in making this cut; that it would have removed less metal, and that it would itself have shown considerable wear. The Taylor-Newbold saw although pushed to practically the limit of the machine showed absolutely no signs of distress and was able to continue the performance without appreciable deterioration of the cutting edges. In fact, those in charge of the machine shop assured the writer that the teeth in this 36-in. saw would run for two weeks and over without regrinding.

In the matter of regrinding, the Tabor Manufacturing Company have a very effective method of managing the same. The teeth in this saw can be removed and a new set applied within twenty minutes, the worn set being shipped off for regrinding at the factory. The Taylor-Newbold method of setting the teeth has a very pronounced advantage which any practical man will readily appreciate. In sawing into heavy solid material there is always a tendency for the material to pinch the saw. The saw in question not only has considerable clearance, but in the event of pinching taking place a wide tooth saw key could be backed out and the tooth removed, which would give a distance of 14 ins. along the periphery between the next pair of wide teeth. The saw, therefore, could be run out of any ordinary piece of work. The teeth are arranged with a wide and narrow tooth placed alternately so that one cuts into the metal and the next clears the edges.

There is no doubt that the Taylor-Newbold saw as made by the Tabor Manufacturing Company is a more expensive saw than the ordinary cold metal saw, but in considering the question of cost there is great satisfaction in knowing that it can cut from eight to ten times the amount of metal in a given time, and after its high speed steel teeth have gnawed their way through a refractory piece of metal they will be as sharp and as ready to bite as ever they were. The adjustment by which their height is fixed is such that when in operation every tooth cuts cleanly out its quota of metal and after dropping its hot chip is momentarily cooled in a bath of soap and water and is ready for further work.

Baldwin Pacific Type Engine for the R., F. & P.

The Richmond, Fredericksburg & Potomac Railroad, of which Mr. W. F. Kapp is superintendent of machinery, has recently obtained some 4-6-2 passenger power from the Baldwin Locomotive Works, of Philadelphia, which are here illustrated.

These locomotives are simple slide valve engines with cylinders 20x26 ins. and 68 in. driving wheels. The calculated tractive effort is 26,000 lbs., and as the weight on the drivers is 116,620 lbs., the ratio of tractive effort to adhesive weight is, therefore, as 1 is to 4.48.

The total wheel base is 30 ft. 9 ins., while the driving wheel base is only 12 ft. long. The total for engine and tender is 58 ft. 5½ ins. The main driving wheels are the middle pair, and these wheels are the only ones which

the smoke box end, and the barrel courses are made of ¾ in. steel. The horizontal seams are all of the Vauclain triangular type and they are all placed on top of the boiler.

The heating surface is 2,967.1 sq. ft. in all, the fire box having 176.7, and the tubes 2,790.4 sq. ft. The grate area is 49½ sq. ft.

The dome is placed on the third barrel course and is well forward of the fire box, and the top check is situated somewhat beyond the center of the cylindrical shell of the boiler.

The tender has an ordinary U-shaped tank, carried on a steel frame. The tank capacity is 5,000 gallons. A few of the principal dimensions are given below:

Boiler—Working pressure, 200 lbs.; fuel, soft coal.
 Fire Box—Length 108 ins.; width, 66 ins.; depth front, 66¾ ins.; depth back, 64 ins.; thickness of sheets, sides, ¾ in.; back, ¾ in.; crown, ½ in.; tube, ½ in.

pressure valves the inside rings are good and the outside rings defective, a blow will occur at one or both ends of stroke. If either inside rings are defective, it will result in a great increase of lead and a corresponding delay of cut-off. The low pressure or outside admission valve would be affected the same, the difference occurring in the outside rings being defective, all of which would very materially affect the proper and economical working of an engine. Therefore, in the following test, it will be noted that reverse lever is to be placed in a position to partially open ports and then in a position to fully open ports. This will enable us to test each ring, for if port is partly open, one ring must form the joint between the live and exhaust steam, whereas, if port is fully open, we have two rings to make the joint.

Now, as high pressure blows are never

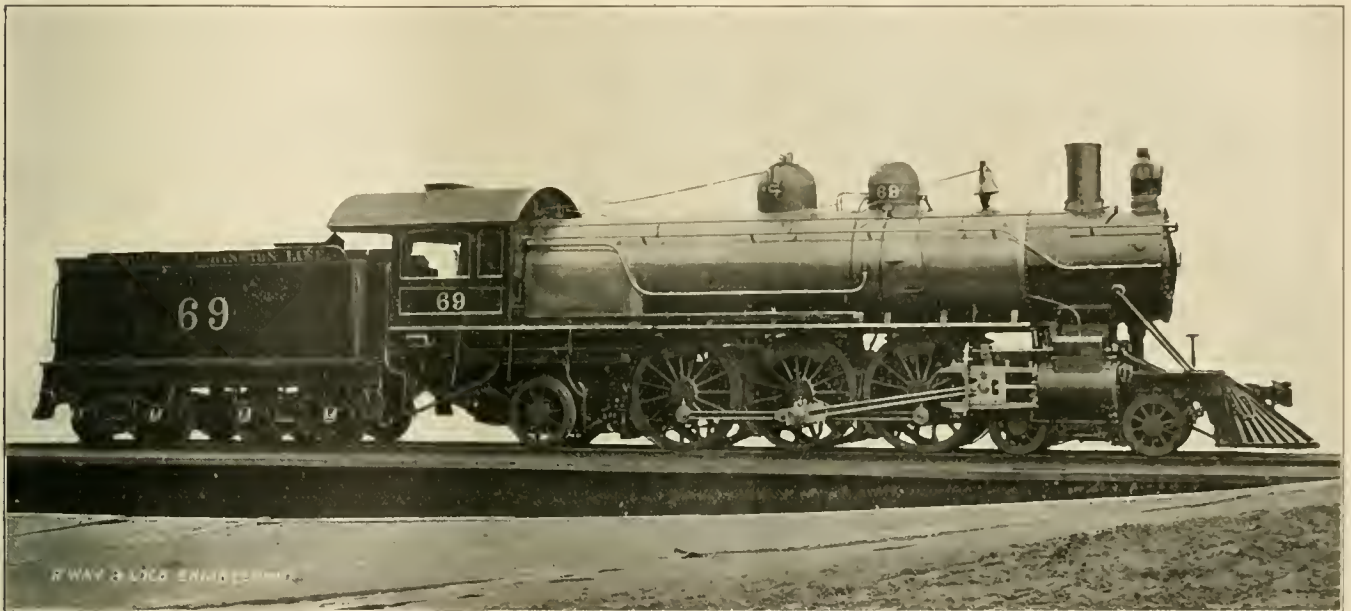

W. F. Kapp, Superintendent Machinery.

RICHMOND, FREDERICKSBURG & POTOMAC 4-6-2 EXPRESS ENGINE.

Baldwin Locomotive Works, Builders.

have no flanges. The springs are overhung and the drivers and the carrying wheels at the rear are all equalized together. The carrying wheels have inside journal bearings, which arrangement always gives an engine of this class a very symmetrical appearance. The crosshead is of the two guide-bar type, and the piston is fastened to it with shoulder and nut. The valve gear is of the usual indirect kind and the upper rocker arm pin works in a small crosshead in the valve rod, and this valve rod works through a guide in the spectacle frame or guide yoke. The rods are all of I-section and the side rods have solid ends.

The boiler is a straight top one with semi-wide fire box. The roof sheet is level, but the crown sheet slopes slightly toward the back. The staying is radial. The boiler is 64 ins. outside diameter at

Water Space—Front, 4 ins.; sides, 3 ins.; back 3 ins.
 Tubes—Material, steel; wire gauge, No. 12; number, 244; diameter, 2¼ ins.; length, 19 ft. 6 ins.
 Driving Wheels—Journals, main 9x12 ins.; others 8½x12 ins.
 Engine Truck Wheels—Front diam., 33 ins.; journals, 5x10 ins.; back diam., 42 ins.; journals, 7¼x12 ins.
 Weight—On driv. wheels, 116,620 lbs; truck front, 31,960 lbs.; back, 31,980 lbs.; total engine, 180,560 lbs.; total engine and tender, about, 280,560 lbs.

To Locate Blows on Tandem Compound Engines.

BY S. H. DRAPER,

Road Foreman of Engines, R. M. Div. Northern Pacific, Missoula, Mont.

With strict attention to sound of exhaust while engine is working hard and slow, many blows that occur may be quite accurately located making standing tests for final decision.

It may seem unnecessary to test individual valve rings, however, if on the high

heard at the stack, excepting the intermediate bushing blows, and with few exceptions high pressure blows result in giving a heavy exhaust at one or both ends of stroke, on the defective side. If at one end, it would indicate valve ring or by pass valve, and if at both ends it would indicate cylinder packing or two valve rings in bad order. The exception would be in case of a joint blow in both high and low pressure valves or cylinders, which would tend to make exhaust sound more normal, excepting blow at stack. Conditions are reversed in case of low pressure blows, defects being on the side having light exhaust at each end of stroke. The cause of light exhaust on defective side is due to the volume of steam supplied to low pressure cylinder, being limited to the amount that passes through high pressure cylinder. Therefore, any low pressure blows result in

reducing the pressure and hence the sound of exhaust.

The exception would be if high pressure on same side was blowing (the intermediate bushing excepted), as this blow, while a high pressure blow goes direct to stack and would not raise pressure in low pressure steam chest. Hence, if engine has too light exhaust on one side, accompanied with blow at stack, test for low pressure blow on that side.

set brakes and block wheels, give engine steam enough to promptly seat by-pass valves and packing rings, valve rings and cylinder cocks are referred to in numerical order, beginning with front one, as No. 1, etc.

New Equalizer Truck for Tenders.

The sides and transoms of this truck consist of 13-in. rolled steel channel beams cut to the required lengths and

count of the Siberian Railway being such an important highway in the Russo-Japanese war. This contract is important also in that it discredits the idea that Russia did not intend to purchase any of her supplies in the United States, but would look to European markets for her requirements.

The order for jacks is being rushed forward, as they are urgently needed for the repairing of permanent way and for the construction of new track. It is a significant coincidence that on the same day that the Duff Manufacturing Company received the contract from Russia, they received an inquiry for a rush order of Barrett jacks for the Japanese railways. It was a peculiar incident that the two warring nations should send specifications for the same article to the same firm on the same day.

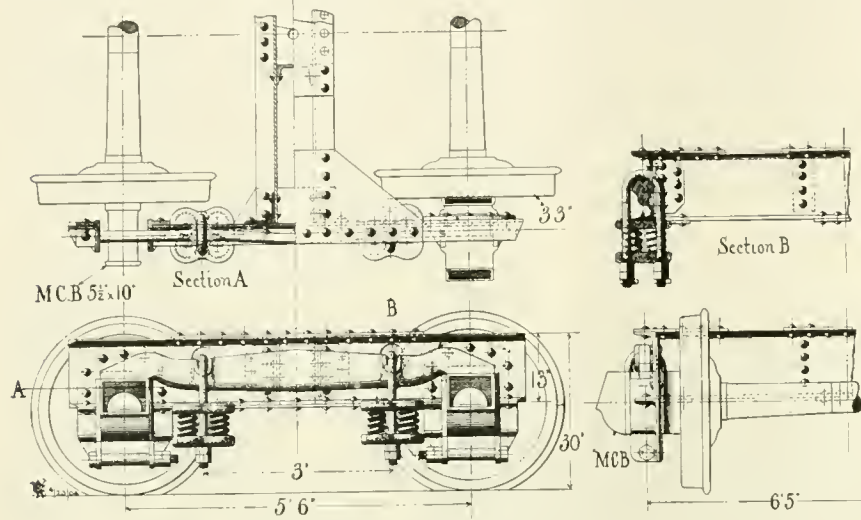

NEW DESIGN OF TENDER TRUCK.

If a blow occurs at the stack, only when main pin is passing from back to forward center, it would indicate a blow at intermediate bushing, forward low pressure by-pass valve or valve ring 7. If a blow occurs at the stack, only when main pin is passing from forward to back center, it would indicate a blow at back low pressure by-pass valve or valve ring 6. However, the two preceding blows may both exist, in which case they would resemble cylinder or valve packing blow, but ordinarily one would be heavier than the other, while the cylinder and valve packing blow would sound the same for each stroke. Therefore, the difference can generally be determined. However, a low pressure valve blow gives a slight intermittent sound and is hard to distinguish from cylinder packing blow. The intermittent sound of low pressure valve blow is caused by variation of pressure in steam chest, together with one valve ring only being defective.

In order to prevent confusing by-pass valve blow with other blows, it is recommended that they be inspected before making tests for other blows. It is also recommended that cylinder cocks be closed, opening those only that would show the blows, using a couple of suitable wedges or other means for the purpose. This brings more of the steam that is blowing by to one point, more clearly indicating the blow.

Indicator plugs may be used if preferred or pressure relief valve may be removed. In making standing test, always

united by gusset plates and connection angles. The ends of the side pieces are notched out to receive light cast metal pedestals with flanges which guide the journal boxes. The equalizers are of cast metal and support U-shaped hangers, one leg of each hanger passing through a hole in the web of a side piece. The springs rest upon cast metal seats located beneath the side pieces and the latter are supported upon the springs which are placed adjacent the journal boxes. To adjust the frame of the truck and the tender along with its coupler to the required distance from the track it is necessary only to turn the nuts upon the hangers.

The equalizer truck now in general use under tenders is comprised of a multiplicity of parts and the aim has been to simplify the construction and reduce the number of parts, and at the same time produce a truck which has the requisite spring capacity. The design illustrated was worked out by Mr. R. C. Wright, of Philadelphia, Pa.

Barrett Jacks for Siberian Railway.

The Duff Manufacturing Company, Pittsburgh, Pa., sole makers of the Barrett jacks, have received a contract for a carload of Barrett track jacks for Russia. They are to be used on the Siberian Railway. This road, and in fact nearly all the Russian railways, have been using Barrett jacks for a number of years, but this contract is unusually large on ac-

Convertible Sander.

This is my new direct pressure convertible No. 7 sander. The air is admitted into the supply pipe between the trap and the sand box and the sand is forced through the double ended loose tube to rails. This tube can be removed if the air should fail from any

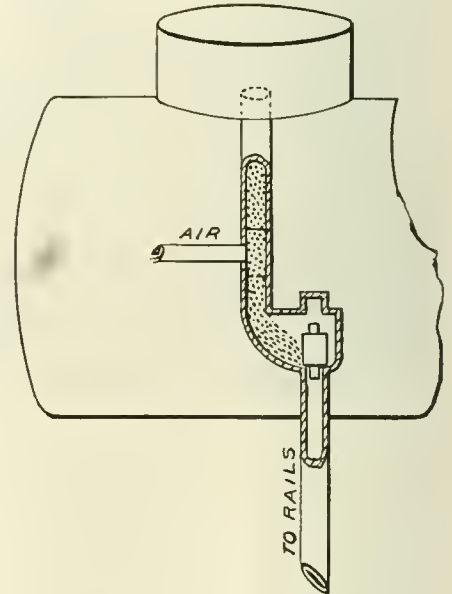

WATTERS' CONVERTIBLE SANDER.

cause and the sander then becomes a gravity feed device. J. H. WATTERS, Augusta, Ga.

Locomotive Building.

After several years of rush work, the demand for locomotives is becoming normal and some people are alarmed lest a depression of business is impending. We do not think there is any danger of dull times in the near future; in fact, we think the steady ordinary business is much more healthy than an exciting boom.

Some alarm has been felt because the Baldwin Locomotive Works have been

gradually reducing their force of late. The number of men employed in the works has been cut down about 3,000 since the beginning of the year, but a considerable part of the men dropped have been employed on building improvements.

To-day the force is less than 15,000. To retain this number it has been found necessary to cut down the working hours of a large part of the force.

The company did such a great business for three or four years that it was compelled to enlarge its facilities. With the present shortage of business this has had the effect of enabling the firm to turn out work in a very short time. Where it formerly required from five to six months to complete an order, the same contract can now be filled in from two to three weeks.

Mallet Articulated Compound for the B. & O.

The Baltimore & Ohio Railroad, of which Mr. J. E. Muhlfeld is the general superintendent of motive power,

This arrangement places the high pressure cylinders almost in the center of the engine. The low pressure cylinders are at the smoke box end and the saddle belonging to them occupies the space between the frames but is not joined to the smoke box or boiler in any way. The weight of the boiler at the forward end rests upon two sliding supports which may be seen in the spaces between the forward driving wheels.

The frame itself is jointed just in front of the rear set of driving wheels and this is why the word articulated is used to describe the type. There is a flexible steam pipe which conveys high pressure exhaust steam to the low pressure steam chest, and the exhaust from the low pressure cylinders is conveyed to the smoke box in a pipe which is capable of adjusting itself to the movement which takes place between boiler and frames. The six forward driving wheels with their frames constitute practically a guiding truck which swings about a point almost in the cen-

ter, and always remains the same without reference to the position of the reverse lever.

The boiler is of the straight top style with radial stayed crown sheet. The barrel measures 82 ins. inside, at the smoke box end. There are 436 tubes $2\frac{1}{4}$ ins. diameter and 21 feet long. These tubes give a heating surface of 5,366.3 sq. ft. The heating surface in the fire box amounts to 219.4 sq. ft. and the total heating surface is, therefore, 5,585.7 sq. ft. The grate area is 72 ft. The boiler carries 235 lbs. steam pressure and when the problem is worked out on the master mechanics' formula, the tractive effort of this engine is about 70,000 pounds, which is more than 10,000 lbs. greater than the tractive power of the heavy tandem compounds built for the Atchison, Topeka & Santa Fe, which we illustrated in June, 1902, page 274. The ratio existing between tractive power and adhesive weight is as 1 is to 4.77. All the wheels in this engine are flanged. There are two $9\frac{1}{2}$ ins. Westinghouse air pumps on the left



MALLET 4-CYLINDER ARTICULATED COMPOUND FOR THE B. & O.

has just received from the American Locomotive Company a Mallet type articulated compound locomotive. The engine was built at their Schenectady shops and weighs 334,500 pounds. The cylinders are 20 and 32x32 ins. and the driving wheels, which are twelve in number, are 56 ins. in diameter outside the tires. The driving wheels are grouped together in what amounts to two separate trucks of six wheels each.

The rear six drivers are actuated from the high pressure cylinders the saddle of which is bolted to the bottom of the boiler in the usual way. The dome is placed on the second course and the steam pipe five inches in diameter, passes down each side of the boiler and feeds the high pressure steam chests.

ter of the engine. Its motion to right or left, below the boiler, is possible on account of the sliding supports which carry the weight, and the flexible pipe connections. The valves of this engine are of the piston type for the high pressure cylinders, while the low pressure cylinders have the Allen-Richardson valves. The greatest travel of the valves is 6 ins. The high pressure valves have $1\frac{1}{8}$ ins. outside lap, while the low pressure valves have 1 in. lap. The inside clearance of the valves is $\frac{1}{4}$ of an inch while the lead is $\frac{1}{8}$ in. forward and back for both engines. The valve gear used for both engines is the Walschäert motion. One of the peculiarities of this motion is that the lead is constant for long or short cut

side and the boiler is supplied by two Hancock injectors of 5,000 gallons capacity. The engine is provided with two sand boxes and the dome is very low and wide. The whistle and safety valves are placed directly in the roof sheet just in front of the cab.

The tender has a steel channel frame and the water capacity of the tank is 7,000 U. S. gallons and 13 tons of coal. A few of the principal dimensions are appended for reference:

General Dimensions—Wheel base, driving, 10 ft., 10 ins.; wheel base, total, 30 ft. 8 ins.; wheel base, total, engine and tender, 64 ft. 7 ins.
Cylinders—Diam. of cylinders, 20 and 32x32 ins.; diam. of piston rod, $3\frac{3}{4}$ ins.; size of steam ports, L. P. 20 ins., 23 $\frac{1}{2}$ ins.; size of exhaust ports, L. P. 20 ins., 3 ins.; size of bridges, L. P. 15 $\frac{1}{2}$ ins.

Wheels, etc.—No. of driv. wheels, 12; diam. of driv. wheels, 56 ins.

Boiler—Thickness of plates in barrel and outside of fire box, 1, $\frac{3}{4}$ and $\frac{5}{8}$ in.; fire box, length, 108 $\frac{1}{2}$ ins.; width, 96 $\frac{1}{2}$ ins.; depth, front, 80 $\frac{1}{2}$ ins.; back, 72 ins.; plates, thickness, sides, $\frac{3}{8}$ in.; back, $\frac{3}{8}$ in.; crown, $\frac{7}{8}$ in.; tube sheet, $\frac{1}{2}$ in.; water space, 6 ins. front, 5 ins. sides, 6 ins. back.

Tender—Style, water bottom, Hopper type; wheels, diam., 33 ins.; journals, diam. and length, 5 $\frac{1}{2}$ ins. dia. 10 ins.; wheel base, 20 ft. 2 ins. Weight of tender in working order, with fuel and water, 143,000 lbs. Total weight of locomotive and tender in working order, 477,500 lbs.

Book Reviews.

Twentieth Century Locomotives, by Angus Sinclair Company. Publishers, RAILWAY AND LOCOMOTIVE ENGINEERING, New York. 1904. Price, \$3.00.

As "the apparel oft proclaims the man" so in this case the title of the book practically tells what it is. Twentieth Century Locomotives—the book is modern, it is up to date. Its pages are filled with matter drawn largely from the columns of RAILWAY AND LOCOMOTIVE ENGINEERING, and a careful selection has been made in the articles used so that while the field covered is wide and the work comprehensive, yet there are no vain repetitions.

The book is a storehouse of information, and treats on the design construction repairs and operation of railway machinery and of modern locomotives both simple and compound. The shop man will find workshop operations carefully described and fully illustrated, written by men who not only know how to do things but have done them, and have set down the results of their experience. Shop tools are also described and illustrated. Shop receipts are given.

Engineers and firemen will find much to interest them in how to make quick road repairs in case of breakdowns, the location of blows and pounds in simple and compound engines, operating hints, and easy calculations concerning train resistance, tractive power, etc. Everybody can learn valve setting, and become familiar with the functions of the different parts of locomotive valve motion and with piston and D slide valves.

There are useful tables, definitions of engineering and technical terms, descriptions, illustrations and dimensions of all the types and varieties of modern standard locomotives. The book is profusely illustrated both with line cuts and half tones. The pages are the standard railway size, 6x9, and there are 670 of them. The work has been most carefully indexed, so that any question which comes up can readily be decided by reference to the book. It is intended for use by railway men irrespective of rank who are eager to learn things about railway machinery. The title of the book shows it is modern and the information given is up to date.

Train Rules and Train Dispatching, by H. A. Dalby. Publishers, The Derry-Collard Company, New York. 1904. Price, \$1.50.

This book by Mr. Dalby, train dispatcher on the Northern Pacific at Glendive, Mont., has appeared at a very opportune time. The subject of train dispatching and the interpretation of train rules is always important, but it becomes even more so when we consider that the work on all our railways has been steadily increasing of late years.

The book is neatly bound in leather and is of pocket size, being 6x4 ins. There are a few pages in the beginning of the book giving the history of the first telegraphic train movement made in this country, an explanation of what the American Railway Association is, and what are its aims and objects. Standard time is explained on an insert map showing the areas covered.

The author takes up the subject of time tables, and gives us some useful definitions and points out some distinctions in the meaning of words which are necessary to bear in mind. The forms of train orders are gone into very carefully and the meaning and the scope of the orders is explained.

In the section on train order signals, there are a number of well drawn colored plate illustrations giving the various forms of train order signals, automatic and the interlocking block signals and automatic disk signals, with brief explanation of what they stand for and what they mean.

There is some good sensible advice addressed to the operator, who is cautioned to remember that he is at all times the eyes and ears of the dispatcher, and the importance of his careful observation and of his accuracy in reporting train movements are put squarely before him. The dispatcher and the train men are dealt with also, and the necessity of harmonious work is dwelt upon. Each should be better acquainted with the duties of the other. The author advocates the practice of letting dispatchers go out on the road in the company's time and get a practical idea of what the engineer and the train men have to contend with. Both sides should work understandingly together. There are also some suggestions to the young train dispatcher. Under the head of "The Department of Train Dispatching—What Is It?" the work of moving trains over the road and all the additional work which is implied under that name, is very clearly brought out.

The standard code, with colored illustrations, closes a work of 220 pages. This book would be useful to engineers, firemen, and trainmen as well as to dispatchers and operators and the higher officials.

New York Air Brake Catechism, by Robt. H. Blackall. Publisher, Norman W. Henley, New York. 1904. Price, \$1.25.

"Up-to-date Air Brake Catechism," by Robert H. Blackall, comes to us fresh from the press. Like Blackall's up-to-date catechism on the Westinghouse air brake, this book shows care and study in its construction. It begins with the plain triple valve, treating that subject fully, then proceeds in a progressive manner to the types of quick action triple valve used by the New York Air Brake Company. Next the engineer's brake valve, beginning with the earlier types and coming up to the present 1902 model, is fully illustrated and discussed. Then the air pump is taken in hand and treated in a full and comprehensive manner. Not alone is a description of the pump given, but all the ailments it is subject to, symptoms of troubles and remedies. The several pump governors come in next for their full share of treatment. Then comes a very liberal chapter on piston travel, its advantages and importance of uniformity. The retaining valve, the combined automatic and straight air brake equipment for engines and tenders, high pressure control, and signal system are fully dwelt upon. Water brakes for all types of engines, including simple and compound types, are handled in detail. The chapter on train handling is full and complete.

The book concludes with an excellent chapter on technical data, formulae and rule, treating liberally on braking power, leverage and other kindred subjects. In addition to the text proper, the book contains an excellent index of the subjects treated, making it easy to find any particular piece of information desired.

The book is now on sale at \$1.50 per copy, stiff board binding. Send us your order at once.

The Railway Year Book for 1904 has been received from the press of the Railway Publishing Company, Ltd., of London, England. This book, which sells for two shillings and six pence, contains information concerning the railways of the British Empire. It is now in its seventh year of publication and has been compiled by Mr. G. A. Sekon, editor of the *Railway Magazine*. A map of each railway line is given and also a list of the directors, the names of the chief officers and a brief historical sketch. Three railroads in South America owned by English companies are also included in the book. They are Argentine North-Eastern, the Buenos Aires Great Southern, and the Leopoldina. There is besides the specific information about each road, a great deal of general railroad information, tables, statements and statistics. A few pages at the back of the book called the railway officer's "Who's who" gives

brief biographical sketches of prominent English railway men.

"The Only Way," All the Way.

The Chicago & Alton is soon to have a new short line between St. Louis and Kansas City. The "cut-off" will be opened some time in June. Then the distance from St. Louis to Kansas City will be only 279 miles.

The new 65-mile cut-off which shortens the St. Louis-Kansas City Line is level and straight, the maximum grade being only twenty-six feet to the mile—that is half of one per cent; the maximum curvature is only one per cent., the road is properly called an "air line"—as ninety-two per cent. is perfectly straight track. There is one tangent of eighteen miles and another of fourteen miles, but these tangents could properly be called a straight track for thirty-two miles. The bridges are of steel, the culverts are of concrete, and the road, which is magnificently built, is ballasted with rock. The tracks have eighty-five pound steel rails each, 133 ft. long. There are thirteen passing tracks, or sidings, of three thousand feet each, which makes a total of over seven miles of passing tracks. There are no grade crossings for railroads and very few grade crossings for country roads. Four daily trains in each direction will be operated, and the time tables and equipment will equal in every way The Chicago & Alton's noted Chicago-St. Louis service.

Spatters is the name of a neat little monthly publication devoted to the interest of employees, friends and customers, got out by the Acme White Lead and Color Works. The editorial staff consists of Messrs. A. M. Woodward, V. W. Hartman and S. A. Jewell. Under the appropriate heading of "Factory Notes" *Spatters* "hands out" a little good humored ralliery to the foreman of the mixed paint department No. 1, who, it says, has lately assumed an air of importance owing to the arrival of a daughter in his household. "Representative Business Houses" is a little "write up" for the Strother Drug Company and for Hornick, Hess and More. Under "Helps to Sell Paint" an attractive window display of Acme goods is reproduced. An illustrated description of how and where Neal's enamels are made is given and many little paragraphs and bits of information make the May issue very interesting. The Acme White Lead people of Detroit, Mich., will be happy to *Spatter* any one who will write to them for a copy.

We have received a very interesting catalogue from the Cambria Steel Company of Philadelphia. It is devoted to the consideration of cars made of struc-

tural steel shapes. There are a number of these cars shown in some half tones which are exceedingly clear and well defined, and there is descriptive letter press and the principal dimensions are given. Among those shown may be mentioned the ordinary low side drop door gondola, the center dump high side hopper ore bin car, the side and center dump hopper car, the hopper with trussed sides, the long gondola with drop ends and wooden floor, the hopper bottom gondola with rack for coke, sixteen drop door gondola and a coke bin hopper car. A glance through this artistic catalogue gives one a very good idea of what is being done in the building of cars with structural steel. Write the Cambria people at Philadelphia if you would like to get a copy.

The Union Switch & Signal Company, of Swissvale, Pa., have issued section No. 12 of their catalogue of interlocking



VIEW OF A SWISS RUNNING SHED AND YARD.

and signaling devices. This issue deals with the Union electric semaphore and the Union disk signal. In it the types of signals, bridges, bracket posts, electric operating mechanism, slot signal mechanism, mechanism frame details, running gear, etc., etc., are all given with order number and prices. This company has also issued an assemblage price list of the Westinghouse electro-pneumatic interlocking switch and signal system, electro-pneumatic interlocking and push button machines, operating and locking devices for switches and frogs, electro-pneumatic signals and auxiliary appliances. The company will be pleased to send either or both of these catalogues to any one who will apply to them direct.

Square Roundhouses.

The mere question of doors is almost enough to decide the question of

roundhouse construction in favor of the square as against the circular form of running shed. Mr. Geo. P. Nichols, however, gave a number of other reasons in favor of the square ground plan in a paper recently read before the Western Railway Club.

The disadvantages of the circular form are, briefly, the presence of a large turntable in a pit on the line of entrance and departure, also about 50 ft. between turntable and shed doors, all exposed to the weather, and capable of being easily blocked with snow. In a 50-stall roundhouse there are 100 doors, all capable of being blocked with snow, all capable of sagging and getting out of repair, all shutting badly, and two or more being constantly opened for engines to pass in and out, causing a tremendous loss of heat in the shop during the winter. These things not only entail discomfort on those using the house, but they cost money, be-

cause they are like making a man work with blunt tools. In the matter of utilization of space the circular form is narrow at the entrance and wide at the extreme end, which is an inconvenient disposition of space. The perfectly circular roundhouse is incapable of any extension. When built it is a unit, complete in itself and cannot be enlarged.

A 50-stall engine house built on the square or, more correctly, on an oblong plan, presents some admirable features. In the first place, the large number of doors is reduced. There can be a single pair, or even one sliding, nonstickable door put in, and through one opening, if desired, all the engines can enter and leave. The oblong house has greater floor area, and the space is better distributed. Through the center there should run a 70 ft. transfer table, with twenty-five stalls on each side. The

whole floor area is roofed over and the movements of engines cannot be blocked by snow, nor any work interfered with by rain. The elimination of the doors practically solves the heating problem.

The transfer table, having only to traverse half the length of the house to place an engine in either of the extreme stalls, its speed can be made equal to that of the rotation of a turntable, so that practically the time element in handling, will be about the same for either kind of a shop. The oblong form of shed is capable of extension, and two, four, six, etc., stalls may be added at either end as occasion requires. The square or oblong form lends itself most readily to the operation of overhead cranes placed above two or more stalls as required and a

General Electric—New York Central Electric Locomotive.

The new electric locomotives which are being built for the New York Central & Hudson River Railroad Company at Schenectady, by the General Electric Company and the American Locomotive Company, differ radically in their electrical features from any electric locomotive hitherto constructed.

The motors are bi-polar gearless, the magnetic circuit, the field windings and the motor poles being integral with the locomotive frame and spring supported. The pole faces which are laminated are vertically tangential to the armature thus providing for vertical movement of the locomotive frame with attached poles without affecting the armature air gap. The armature is assembled on a quill which is pressed solidly on the axle.

River line and as far as North White Plains on the Harlem Division, a distance of 34 miles and 24 miles, respectively.

These conditions were, briefly, that the successful bidder should furnish an electric locomotive capable of making two regular successive trips of one hour each between Grand Central Station and Croton with a total train weight of 550 tons, a single stop in each direction and a lay over not to exceed twenty minutes. In addition to this it was provided that a similar schedule should be maintained with somewhat lighter trains making more frequent stops. Finally, it was provided that with a total train weight of 435 tons, the electric locomotive should be able to run from Grand Central Station to Croton without stop in forty-four minutes, and, with one hour lay over, be

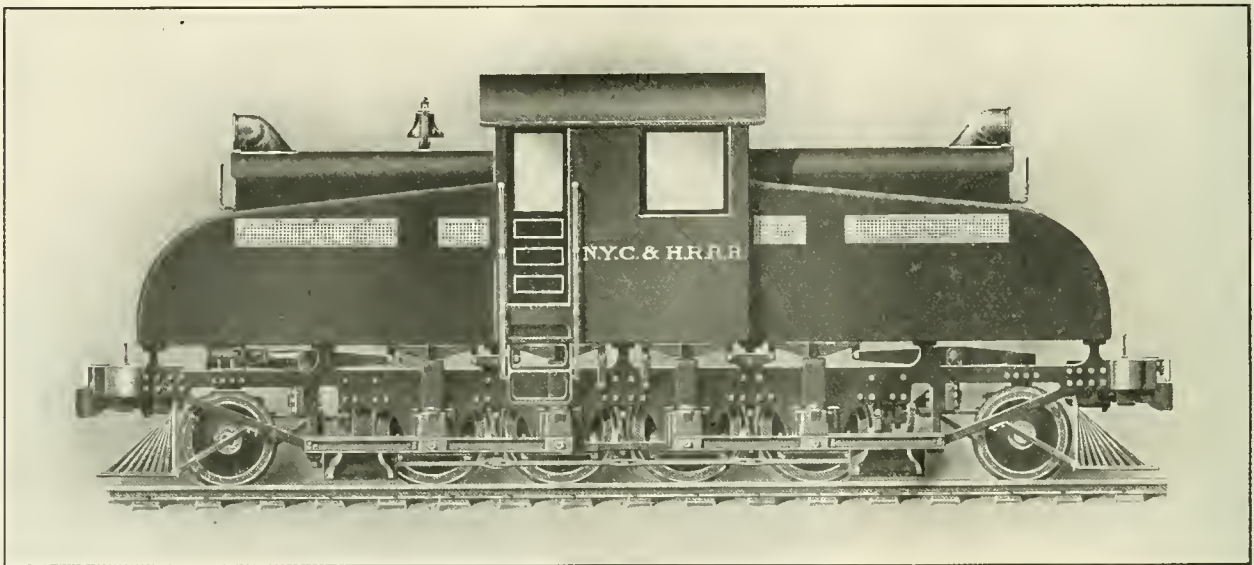

GENERAL ELECTRIC—N. Y. CENTRAL ELECTRIC LOCOMOTIVE.

convenient location of drop pits can be arranged.

The square form of running shed does not provide a means of turning an engine and a turntable would have to be provided or if not that, a Y can be put in, not necessarily on the direct line of movement in or out of the shop. Mr. Nichols remarked that it might be possible to design a transfer table with a frame to carry the tracks which could be made to rotate. The nearest approach to the square roundhouse which the speaker mentioned is the arrangement adopted by the Terminal Association of St. Louis for handling engines near the entrance of their station.

In this connection we may mention that in Great Britain and on the Continent the square style of running shed is used. Our illustration shows a modification of the same idea in Switzerland.

The dual weight of the assembled rotating part, including the armature, axle and wheels, is less than on many steam locomotives and there being no uncompensated reciprocating parts there is a perfect rotative balance.

This design was submitted in accordance with specifications prepared by the Electric Traction Commission appointed by the railroad company, the members of which are Messrs. Wm. H. Wilgus, fifth vice-president, N. Y. C. & H. R. R. R.; John F. Deems, general superintendent of motive power of the railroad company; Bion J. Arnold, Frank J. Sprague, and George Gibbs. The secretary of this commission is Mr. Edwin B. Katte, electrical engineer of the railroad company.

This commission, after careful deliberation, had prescribed the conditions which must be fulfilled by electric locomotives taking the place of steam locomotives as far as Croton on the Hudson

able to keep up this service continuously. This last schedule is the equivalent of the present timing of the Empire State Express, though the latter has a somewhat lighter train.

Specifications embodying these conditions were prepared by the commission and sent to all the principal electrical manufacturing companies both here and abroad. It will be observed that no restriction was placed on bidders as to whether direct or alternating current was to be used. The successful bidders were the General Electric Company in conjunction with the American Locomotive Company. The choice of a direct current type of locomotive was dictated largely by its known reliability of service, owing to the amount of experience which has been accumulated with the direct current motor.

The new electric locomotive will be 37 feet in length over all. The wheel base will consist of four pairs of motor

Responsibility

for the failure of devices to properly feed oil, of bearings to sufficiently retain oil, of oils to hold up under the heavy duty and for all the trouble that can follow (and you know what *that* means, Mr. Locomotive Engineer), may be hard to place and often IS.

But the ENGINEER is the man who is held responsible in the superintendent's office. It is HE who is carrying many lives or great values at a speed where a mistake may mean disaster.

Things have GOT to go right, if he can possibly make them. That is why

DIXON'S FLAKE GRAPHITE

is used by the great majority of locomotive engineers today.

It will do this work of stopping friction troubles; it will cool hot-pins and keep them cool; it will make possible perfect cylinder and pump lubrication and make things go right from start to finish.

IT WILL BECAUSE IT ALWAYS HAS!

Many railroads furnish it because their practical men knew that, without it, heavy locomotive duty was hardly possible, and were bound to have it.

Would you like a sample?

Write for our New Booklets, "Graphite as a Lubricant" and "Oil vs. Grease."

**JOSEPH DIXON
CRUCIBLE CO.
Jersey City, N. J.**

wheels and two pairs of pony truck wheels, the length of the total wheel base being 27 feet; and of the rigid wheel base consisting of the four pairs of motor wheels 13 ft.

The diameter of the driving wheels will be 44 ins. and of the truck wheels 36 ins. The driving axles will be 8½ ins. in diameter.

It will be what is known as a double tender and will weigh approximately 190,000 lbs.

The frame will be of cast steel, the side and end frames being bolted together at machined surfaces and stiffened by cast steel cross transoms. The journal boxes and axles will be designed to permit sufficient lateral play to enable the locomotive to pass easily around curves of 230 foot radius.

The superstructure of the locomotive is to be of steeple form so designed as to offer the least practicable wind resistance consistent with the adequate

ductors will be designed so as to avoid eddy currents and will be soldered directly into the commutator segments.

The commutator will be supported on the quill. The commutator segments will be made of the best hard drawn copper and will have the cars integral with themselves. The brush holders will be made of cast bronze and mounted on insulated supports attached to the spring saddle over the journal, maintaining a fixed position of the brush holder in relation to the commutator.

Unlike the ordinary four-pole motor where the magnetic circuit is made through a separate box casting, the magnetic circuits in this type of electric locomotive are completed through the side and end frames. The pole pieces are cast in the end frames and there are also double pole pieces between the armature carried by bars which act as part of the magnetic circuit.

The pole pieces will be shaped so that

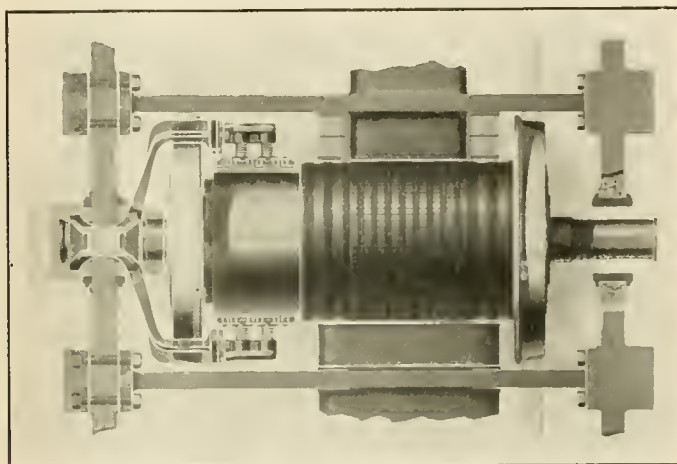

N. Y. CENTRAL ELECTRIC LOCOMOTIVE

housing of the apparatus and its convenient operation. The cab is designed so as to afford a clear view of the track. The whole of the superstructure is to be of sheet steel with angle iron framing, and the doors and windows of the cab are to be fireproof.

The driving power of the locomotive will be furnished by four 600 volt direct current gearless motors, each of 550 horse power. This will make the normal rating of the locomotive 2,200 horse power, with a maximum rating of about 2,800 horse power, or about 50 per cent. greater than that of the largest steam passenger locomotives now in service.

The armatures will be mounted directly on the axles and will be centered between the poles by the journal boxes, sliding within finished ways in the side frames. The armature core will be of the iron clad type, the laminations being assembled on a quill which will be pressed on the axle. The winding will be of the series drum barrel type. The con-

the armature is free to move between them with ample clearance on the sides. As the poles move up and down with the riding of the frame on the springs, they will always clear the armature and provision is made so that the armature will not strike the pole pieces even if the springs are broken. The field coils will be wound on metal spools bolted to the pole pieces and will consist of flat copper ribbon.

The Sprague-General Electric Multiple unit control will be used on this type of electric locomotive. There will be two master controllers in the cab so placed that the operating engineer looking ahead will always have one of these under his hand. The control system will permit two or three locomotives to be coupled together in any order in which they happen to come and to be operated as one unit by the engineer in the leading cab.

The control system will also be semi-automatic in its action as it will provide

a check on the rate of acceleration of the train, which the engineer cannot exceed, while he may accelerate at any slower rate if he so desires. Should two locomotives break apart the control current will be automatically and instantly cut off from the second locomotive without affecting the ability of the engineer in charge to control the front locomotive under his charge. The control system is designed for a minimum of 300 volts and a maximum of 750 volts.

The weight which will rest upon each of the driving wheels of the electric locomotive will be about 17,000 pounds. Proper distribution and division of the weight among axles will be accomplished by swinging the main frames from a system of elliptical springs and equalizing levers of forged steel, the whole being so arranged as to cross equalize the load and furnish three points of support.

The locomotive will be provided with all the usual accessories of a steam locomotive including an electric air compressor to furnish air for the brakes; it will have whistles, a bell and an electro pneumatic sanding device and electric headlights at each end. The interior of the cab will also be heated by electric coils.

In actual performance this locomotive all the usual accessories of a steam locomotive engine hitherto placed upon rails. With a light train the locomotive is expected to give speeds up to 75 miles an hour and with heavier trains similar speeds can be attained by coupling two locomotives together and working them as a single unit. Its tractive force will be greater than that of any passenger locomotive now in existence, and it is believed that in the simplicity and accessibility of its parts and in the provision made in its design to insure continuous operation with the minimum chances of failure, that it marks an entirely new and successful type of electric locomotive.

The B. of L. E. Convention.

The Brotherhood of Engineers which convened its sixth biennial session in Los Angeles on May 11, will continue its deliberations during all of May and part of June. It promises to be a memorable one in the history of the organization.

Over 600 delegates representing 652 lodges are in attendance. In addition to this nearly twice that number of members and their families took advantage of the hospitality of the Southern Pacific and Santa Fe Railroads to go to the Pacific Coast, that wonderland of America. While the delegates are enacting laws, the visiting members are traversing the State after a few days' sojourn in Los Angeles, enjoying

the beauties of the Golden West and the hospitality of its inhabitants.

At the opening exercises in the Mason Opera House, which was packed to suffocation by members and their families that had been admitted by invitation, a gloom was cast over the entire assemblage as the names of P. M. Arthur and A. B. Youngson were mentioned by the different speakers, showing with what reverence they held the memory of their departed leaders. As a proof of their loyalty to their departed chief, a handsomely painted silken banner inscribed with the names of the committee and P. M. Arthur's picture was presented by the Los Angeles members to the Grand Lodge. R. W. Kelly, the spokesman, in presenting the banner, made very appropriate remarks and also mentioned that, while the B. of L. E. was not a body of totalitarians at present, still there was such a vast number among their ranks that the time was not far distant when that would be one of the requirements to gain admission to the order. Delos Everett, the venerable T. G. E., with a few pointed remarks, accepted the custody of this token of esteem by the Pacific Coast brethren.

The address of welcome by the Honorable Mayor, M. P. Snyder, who extended to the B. of L. E., the freedom of the city was happily responded to by that peer among men, J. C. Currin, S. G. A. E. Addresses were also made by John J. Byrne, representing the officials of the Santa Fe Coast Lines, R. H. Ingram, superintendent L. A. Division Southern Pacific; T. E. Gibbon, general consul S. P. L. A. & S. A. Railway, and Gen. M. H. Sherman, president of the L. A. Pacific Railway.

These gentlemen extended a hearty welcome to the members and families and offered to provide them with free transportation over their respective lines. The witty sayings of General Sherman, interspersed with railroad phrases, took the house by storm, as did also the orchestral selection composed by Delos Everett, T. G. E. It is to be hoped that the new laws which will be enacted at this convention will be as beneficial to the brotherhood at large as the previous one, that their policy of live and let live will continue to prevail and that the selections of grand officers which they are about to make will be such that their noble ship will continue to sail in quiet waters.

No doubt the attractive powers of California will be so great that the adhesive weight will take root and bring many of the members of the present convention back at some future period to the sunny clime of that garden spot, California.

J. A. BAKER.



"Throw Away your Glue Pot"

Why have the smell of boiling Glue around you all day, and the waste and expense of boiling dry Glue, when you can for less money use

ARMY & NAVY LIQUID GLUE?

Not a Fish Glue

but a pure hide and sinew glue in liquid form.

The Glue of the 20th Century

will do twenty-five per cent. more work than a fish glue.

No smell. No dirt. Always ready for use.

Let us send you Samples and Prices

WACHTER MFG. CO.
BALTIMORE, MARYLAND

**Keep
Your
Mind
On
It**

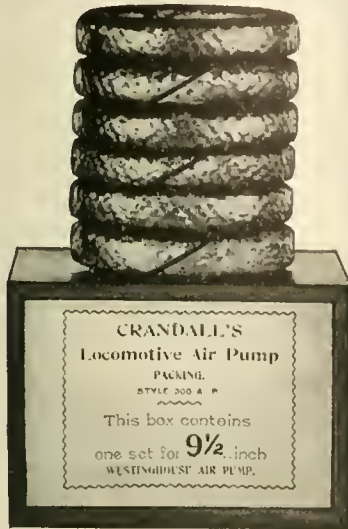

**CRANDALL'S HELIOS
AIR PUMP and
THROTTLE VALVE**

PACKING

**Put Up in Sets
Exact Fit to Rod and Box**

Send Trial Order

The Crandall Pkg. Co.

123 Liberty Street
N. Y. CITY

Chicago Office, 30 La Salle St.

Photographs

of Locomotives from railways all over the globe. The Largest collection on earth. Over 10,000 varieties of Locomotives, cars and trains from American, British, French, German, Italian, etc. railways. Samples 6x8 inches, 25 cents; 8x10 inches, 36 cents, postage paid.

ILLUSTRATED PRICE LIST FREE

THE LOCOMOTIVE MAGAZINE

Full of railway pictures and information.
6 cents a copy, postage paid.

SEND DIRECT TO

Locomotive Publishing Co., Ltd.

The World's Railway Photographer
3 Amen Corner, Paternoster Row, London, E. C.
New York Agents, The Derry-Collard Co., 256 B'way
London Agent, Railway and Locomotive Engineering

Pintsch Side Lights for Suburban Coaches.

The New York Central & Hudson River Railroad have effected an innovation in lighting by introducing side lights in some of their suburban coaches and the results have been so satisfactory that it is probable that many more of their coaches will be equipped with these new fixtures. These new side lamps were developed at the request of Mr. Brazier, of the Central, by the Safety Car Heating & Lighting Company, and the general style of the fixtures, as well as the manner of applying, may be seen in the accompanying illustration.

The side deck center suspension lamp, now known as Pintsch lamp No. 442, has proved particularly satisfactory. It has all of the draught proof features of the standard Pintsch center lamp, and is

sender equipment, and the use of these lamps by the Central has demonstrated that there are no insurmountable difficulties in connection with their employment. It would not do of course to depend entirely upon side lights for illumination, but when some, or all of the center fixtures are retained, the result achieved may truthfully be termed a brilliant one.

The passenger department of the Boston & Albany Railroad at Boston, Mass., have issued an interesting pamphlet called "In the Berkshire Hills of Massachusetts." The publication is artistically illustrated and shows some scenes on Onota Lake and Pontoosuc Lake, the view of Aspinwall and grove, the Inn at Templeton, "Goss Heights" and many other delightful points in the Bay State. It also contains descriptive sketches of



PINTSCH SIDE LIGHTS

giving every satisfaction in service. It is fitted with a 2 flame burner; therefore, it consumes but half the amount of gas that a center lamp burns. These fixtures are suspended from the side deck directly over the seats, as shown in the illustration.

The lamp shown in the second illustration is the Safety Company's No. 373 bracket. These lamps, it will be observed, are fastened to the panels between the windows. They are single flame, open burners, fitted with opal shades and can be depended upon to give satisfaction, especially when used in combination with the regular number of center fixtures.

There are great possibilities in this matter of side lighting for railway pas-

Pittsfield, "The Gem City of Berkshire;" Lenox, "The Beautiful;" Historic Stockbridge, "Picturesque Spencer;" North Adams, Dalton, Hinsdale, Becket, Templeton, Middlefield, Cummington and Worthington, Huntington and "Goss Heights," Blandford, Greenwich, Milford, Warren and Wellesley Farms, all in the historic State of Massachusetts. The 40 page "Summer Homes" folder incorporated with it contains a list of hotels and summer boarding houses on the Boston & Albany R. R. in the Berkshire Hills district and at other points on the line, and one page is devoted to schedule of stage and electric connections from B. & A. Railroad stations to interior towns

H. S. PETERS' BROOKFIELD OVERALLS

have gone to almost every part of the World where Overalls are worn and are everywhere conceded to be the BEST. Every point of material, cut, construction and finish is carefully looked after; the only way that superiority can be attained. Every garment is absolutely guaranteed. The Patented, Fleece-lined, Safety Watch Pocket is alone worth a whole suit of any other make.

I'll send sample suits, charges paid, to any place in the World where mail or express goes, where I have no retail agency; sample materials and full particulars for the asking.

UNION MADE
OF COURSE -
B.L.F. 3 - H.S. PETERS - B.L.F. 171
DOVER, NEW JERSEY, U. S. A.



A New Rip Saw.

Our readers being interested in the progress made in the building of machines designed to help them in their work, are at all times willing to investigate the merits of the new ones brought out. But newness alone will not answer the purpose; this must be one of the points only, for this will not make up for any mechanical defects. It is therefore our pleasure to here illustrate a rip saw which is both new and improved, and which is fully warranted by its makers. Ripping machinery has always been one of their most successful specialties, and this tool is their newest and one of their best products. They introduce it on the market with the confidence that it will meet with the success their others have met because there is a demand now for a machine of just this character. It is of medium size and designed for general work in wood working factories, and short or long stock can be ripped at a very high speed with equal

"Grand Prix" and decoration Legion of Honor, Paris, 1900.

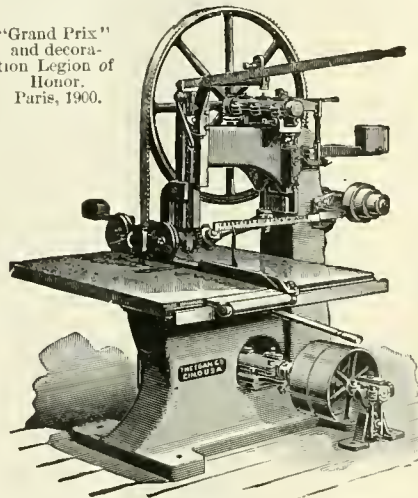

NO. 110, SELF FEED RIP SAW.

facility. Speeds to 160 feet per minute can be furnished.

The feed consists of feeding-in and feeding-out rolls, powerfully geared, and 5 inches in diameter. The rolls are adjustable to and from the saw, so that if a small blade for fine ripping is used, they can be adjusted close to the saw on each side, thus insuring a feed which will not tear or twist the work. The table can be easily raised and lowered to accommodate itself to larger or smaller saws, and when grooving heads are used can be adjusted to suit exact depth of cut. The largest saw used is 16 inches in diameter, and when table is at its lowest point the saw projects 5 inches above the table.

Further particulars about this machine can be had on applying to its makers, J. A. Fay & Egan Company, No. 445 West Front street, Cincinnati, Ohio, who will also send free to those interested and who will write for their new illustrated catalogue of wood-working machinery.

Handy Folding PILOT COUPLER

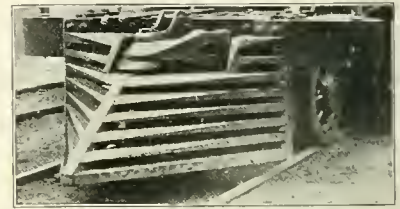

A safe and neat construction for front ends of road locomotives

Handy Car Equipment Co.
Old Colony Building
Chicago

The Twentieth Century Master Mechanic

Won't use solid Mandrels. Cost too much, take up too much room and don't give satisfaction.

Nicholson Expanding Mandrels

Take everything from 1 to 7 inch holes. Take up little room—always ready and you can buy four sets for the cost of one of the solid kind.

Are You Using Them?

Catalogue tells you more about them.

W. H. Nicholson & Co.
Wilkesbarre, Pa.

SMOOTH-ON

Makes permanent repairs on Engines, Boilers, Pumps, etc. Good for all Locomotive Joints.

Write for Catalogue R. L.

SMOOTH-ON MFG. CO.,
572-574 Communipaw Ave.,
JERSEY CITY, N. J.

Telephone, 76 Bergen.

The McCORD BOX
KEEPS OUT THE DUST.

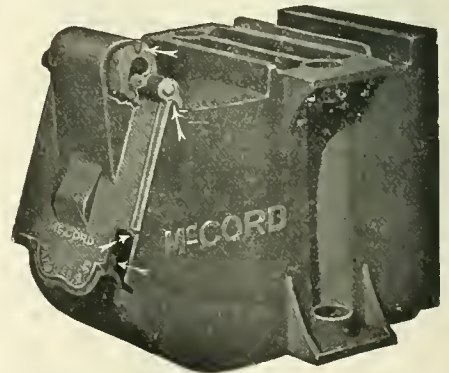

SEE HOW THE LID FITS.

McCord & Company,
CHICAGO NEW YORK

**Q & C - BONZANO
RAIL JOINT**



RAILWAY APPLIANCES CO.
SUCCEEDING
Q & C COMPANY
OLD COLONY BUILDING, CHICAGO.
441 LIBERTY ST. NEW YORK.

A monkey sitting on the branch of a tree and holding on to a twig above him is called "The first spring seat" in Catalogue D of Locomotive Cab Seats, issued by the Stannard & White Co., of Racine Junction, Wis. The catalogue sets forth the merits of the Stannard & White Company's product, and gives details of all sorts of seats, with adjustable and non-adjustable backs, removable backs, cabinet box seat, etc., etc. Also Pool seats, without backs. The catalogue is accompanied with an envelope in which three samples of seat covers are to be found: Grain leather, Kratol No. 8, 17 oz., and Khaki army duck. Write to this firm and get them to send you a catalogue, they will do that free of charge, and judge what kind of seat you would like and what you will have it covered with.

The annual meeting of the stockholders of the Joseph Dixon Crucible Company was recently held at the company's main office, Jersey City, N. J. Of the old board, consisting of Edward F. C. Young, John A. Walker, William Murray, George T. Smith, Edward I. Young, George F. Long and Joseph D. Bedle, President E. F. C. Young, Vice-President and Treasurer John A. Walker, Secretary Geo. E. Long, were re-elected by the directors. Judge Joseph D. Bedle was also re-elected as counsel.

The Falls Hollow Staybolt Company of Cuyahoga Falls, Ohio, inform us that they are selling large quantities of their celebrated hollow staybolt iron to the Norwegian State Railways, and other European roads. They have recently received a large order from the Norwegian State Railways, on the strength of the success which attended the use of former shipments. This is certainly very gratifying to the staybolt company, considering the fact that Norway was supposed to produce the very best staybolt iron in the world. In fact, a large percentage of the raw material from which Falls hollow and solid staybolt bars are manufactured, is imported from Norway. When it reaches this country it is mixed with native charcoal iron of a high grade, which gives an exceedingly high grade product. The native charcoal iron gives the foreign material the requisite tensile strength. This staybolt iron not only possesses the great advantage of high quality, but also many other features well known to leading railway companies, marine and locomotive boiler manufacturers in the United States, Canada, Mexico, Japan and other countries.

The memory strengthens as you lay burdens upon it, and becomes trustworthy as you trust it.—*De Quincey.*

**THE NEW BARRETT
GEARED RATCHET LEVER JACK**

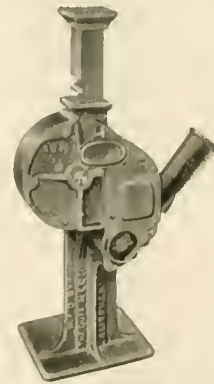

30 Tons Lifting Capacity.

An improved QUICK-ACTING JACK for the rapid handling of loaded freight cars, Pullman cars and all heavy loads. Has the simplicity of an ordinary Lever Jack, the leverage being specially compounded to permit **EASE OF OPERATION and QUICK-ACTION.** No complicated features. Cannot get out of order. Send for Special Bulletin "L" and further information.

PATENTED.
The Duff Manufacturing Co.,
Works: Allegheny, Pa. **PITTSBURG, PA.**

Ball's Official R. R. Standard Watches

16 AND 18 SIZE.



**17 AND 21 RUBY
JEWELS.
SAPPHIRE PALETS**

**BALL'S IMPROVED
SAFETY
DOUBLE ROLLER**

Are without question the finest watches that American talent and skilled labor can produce, and they are giving such universal satisfaction that we have no hesitancy in claiming that they are the best and safest railroad watch on the market.

Tests severe and numerous have proven this fact to the most critical users in all sections of the country, to which thousands of good Railroad and Brotherhood men are ready to certify.

We have an authorized agent in nearly every railroad center. Call on him for information and facts. Write us for descriptive matter.

The Webb C. Ball Watch Co.
Watch Manufacturers
Ball Building, Cleveland, Ohio, U. S. A.

TAKE THE
SUNSET LIMITED
Across the Continent
**SOUTHERN
PACIFIC**
TRAVERSES
Louisiana, Texas, New Mexico,
Arizona, California
Observation Sleeping Cars, Dining Cars,
Day Coaches. Chair Cars,
Excursion Sleeping Cars
OIL-BURNING LOCOMOTIVES
No Smoke! No Dirt! No Cinders!
Write to or inquire at any Southern Pacific
Office, as follows:
170 Washington Street, Boston
349 Broadway, New York City
100 South Third Street, Philadelphia
210 North Charles Street, Baltimore
129 South Franklin Street, Syracuse

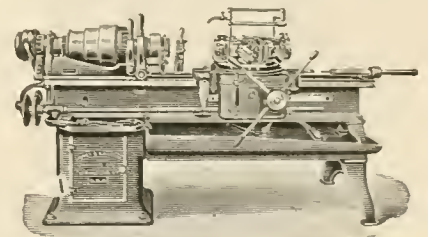

JONES & LAMSON MACHINE CO.

Main Office and Works:
SPRINGFIELD, VERMONT, U. S. A.

A, B, C and Lisber's Code used.

British Office: Jubilee Buildings, 97 Queen Victoria St., London, E. C. France and Spain: Ph. Bonville, 6, Rue Blanche, 6, Paris, France. Germany, Belgium, Holland, Switzerland and Austria-Hungary. M. Koyermann Charlottenstrasse 112, Dusseldorf, Germany.

Flexible Spout

Vertically in straight line. Also laterally. The latest Improvement to

Poage Water Columns

American Valve and Meter Company
CINCINNATI, OHIO.

SEND FOR CATALOGUE

THE DROP SEAT DROPPED.

Shipped Locomotive Builders several large consignments last year. Ask for our seats when your company is ordering new engines. The Mexican Central Ry. Co. is putting our drop seat No. 7 on all their new engines. We make 20 different styles of Locomotive Cab Seats, \$2 up. Send for new Catalog D containing 100 illustrations and full particulars, free. Send 10c. for Complete Camper's Manual; or, How to Camp Out and What to Do, a practical book of 130 pages, worth \$1.

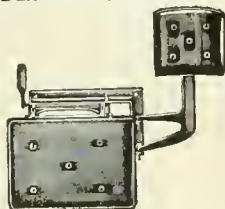

STANNARD & WHITE CO., Racine Jct., Wis.

168 p. **BOOK** on

AIR AND GAS COMPRESSORS FREE

to anyone who will TELL US WHERE compressed-air apparatus is to be installed. It contains valuable Formulae, Tables and Information. Write now. : :

LIDLAW-DUNN-GORDON CO.

116 Liberty Street
NEW YORK

90

The Newton Machine Tool Works of Philadelphia have issued their catalogue No. 38. It is devoted to the consideration of slotting machines and shows a line of them from 6 to 18 ins. stroke. There are among them an arrangement for electric variable speed motor drive, and for belt drive by motor and motor with change gear drive. There are in addition to the regular general service machines some special tools such as 40 in. gear cutting machine, 16 in. traveling head slotting machine, and an armor plate slotting machine. The catalogue, which is well printed and has very clear half tones, and brief description of each machine, will be sent free to anyone who is interested enough to write the company for a copy.

The following list of cars and locomotives were among recent orders received by the Standard Car Truck Company, all to be equipped with the "Barber" lateral motion trucks: Chicago, Lake Shore & Eastern, 250 100,000 capacity cars; Canadian Pacific Railway, 1,600 freight cars; Erie Railroad Company, 200 refrigerators; Erie Railroad Company, 15 elliptical spring milk cars; Delaware, Lackawanna & Western, 1,000 box cars; Delaware, Lackawanna & Western, 500 steel cars; Goodwin Car Company, 60 special dump cars; Great Northern Railway Company, 27 special fish cars; Central R. R. Co. of New Jersey, 10 special cinder cars; A. E. Bryan Co., Chicago, 2 special purpose cars; Norfolk & Western Railway, 4 locomotive tenders; Bismark, Washburn & Great Falls, 1 locomotive tender.

A person who buys books either for business or pleasure finds it convenient to possess a price list which aids him in making selections. Our Book of Books is very convenient for this purpose. It is the smallest standard size and can be kept in a small nook to be ready when wanted.

A neat little catalogue of air and gas compressors comes from the Rand Drill Company, of 128 Broadway, New York. The pamphlet illustrates and briefly describes some of the standard types of compressors made by this company. The lists given are condensed but sufficient information is given to enable a purchaser to make a selection suitable to his requirements. The Rand Drill people will be happy to send this catalogue to any one who applies to them for it, and they will be pleased to furnish prices and other information to those who desire it.

A laborer working on piece work, shovels about 6,000 pounds of coal an hour merely throwing the black diamonds over the side of a car. A locomotive

STANDARD BOOKS

Rustless Coatings; Corrosion and Electrolysis of Iron and Steel.

By M. P. WOOD, Member of the American Society of Mechanical Engineers, American Association for the Advancement of Science; Consulting and Contracting Engineer; Superintendent of Motive Power, late United States Military Railways. 8vo, x+432 pages, 85 figures. Cloth, \$4.00.

Elements of Steam-engineering

By H. W. SPANGLER, Whitney Professor of Dynamical Engineering in the University of Pennsylvania; ARTHUR M. GREENE, JR., Professor of Mechanical Engineering in the University of Missouri; and S. M. MARSHALL, B.S. in E.E. 8vo, v+275 pages, 273 figures. Cloth, \$3.00 (12/6 net).

CONTENTS—Boilers. Boiler Details and Accessories. Boiler-room Auxiliaries. The Slide-valve Steam-engine. Engine Details. Valve Motions and Diagrams. Indicating and Governing Governors and Valves. Condensers and Multiple-expansion Engines.

The Mechanical Engineer's Pocket Book

6th edition. By WILLIAM KENT, A.M., M.E. This is a reference book of rules, tables, data, formulæ for the use of engineers and students. Bound in Morocco, 1100 pages. Price, \$5.00.

Practice and Theory of the Injector

By STRICKLAND L. KNEASS, C.E. It contains an account of the early history of the injector, the development of the invention to its modern forms. Notes on the shape and proportions of tubes and the wear of parts. Gives a review of the theory of injectors, and has numerous tables and tests. 8vo, cloth, \$1.50.

NEW YORK:

JOHN WILEY & SONS

London: CHAPMAN & HALL, Limited

fireman frequently throws 6,000 pounds of coal into a fire box during one hour and places it over the grate so that it will do its best work in generating steam, and besides that, he closes the fire door between every shovelful of coal thrown into the fire box.

The Canadian business of the Allis-Chalmers Company, which recently acquired the Bullock Electric Manufacturing Company, of Cincinnati, will hereafter be conducted by a new organization bearing the name Allis-Chalmers-Bullock, Ltd. The works and principal offices of this important, new Canadian company are in Montreal.

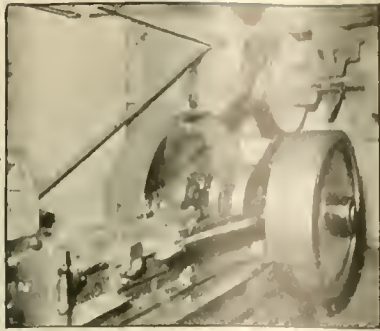

PERFECT BELTS

All belts can be run easy with *Cling-Surface*, do fullest work and not slip. It is a preservative filler for belts, not a surface dressing and not sticky. This belt (Peninsular Tool Co., Detroit) is doing 35 H.P., 180 R.P.M. on 8 ft. centers and is 15 in. slack. Does it easily. Order on trial, test. Pay only if satisfactory.

CLING-SURFACE MFG CO
124-130 Virginia Street
BUFFALO NY

JUST PUBLISHED
—THE—
LOCOMOTIVE UP TO DATE

The greatest accumulation of new and practical matter ever published treating upon the construction and management of modern locomotives, both

SIMPLE and COMPOUND

By CHAS. McSHANE

Author of "One Thousand Pointers for Machinists and Engineers." Special Exhaustive Articles were prepared for this new book by the
Baldwin Locomotive Works
Rogers Locomotive Company
Schenectady Locomotive Works
Pittsburg Loco. and Car Works
Brooks Locomotive Works
Dickson Locomotive Works
Cooke Loco. and Machine Co.
Richmond Loco. and Machine Co.

With contributions from more than one hundred prominent railway officials and inventors of special railway appliances.
736 Pages, 6x9 Inches 380 Illustrations
An Absolute Authority on All Subjects relating to the Locomotive

Bound in Fine Cloth, \$2.50

ONE THOUSAND POINTERS
—FOR—
MACHINISTS and ENGINEERS

By CHAS. McSHANE
(Practical Machinist)

Assisted by CLINTON B. CONGER, Air Brake Expert; J. P. HINE, Mem. Div. 37, B. of L. E.; J. G. A. MEYER, Mechanical Engineer; W. M. F. GOSS, Mechanical Engineer; JNO. C. WHITE, Indicator Expert. The only complete work on the locomotive combining both theory and practice. 342 pages, 187 illustrations.

BOUND IN FINE CLOTH, \$1.50

The only book ever endorsed by the International Association of Machinists. Agents wanted everywhere; write for terms, commissions and club rates. Will be sent prepaid to any address upon receipt of price.

Griffin & Winters, Pub.
171 La Salle St., CHICAGO, ILL., U. S. A.

The Air Brake Convention.

(Continued from page 268.)

[Much of our regular correspondence has been crowded out of this issue to accommodate the Air Brake Convention proceedings.—Ed.]

The next paper taken up was that on standard length of brake beams, suspension of same, and foundation brakes by T. A. Hedendahl, of the Westinghouse Air Brake Company, Denver, Colorado. Mr. Hedendahl said in part:

"The Master Car Builders' standard length of brake beams, 60½ inches from centers of brake heads, approaches the ideal from a theoretical standpoint, that is, a car equipped with standard length of beams and being at rest on perfectly level track, the position of brake shoes against tread of wheels is usually perfect, but unfortunately, after the car enters service and has been subjected to the more rigorous usage due to inequality of track, etc., and especially to the more severe braking conditions on heavy grades, it is not at all uncommon to find that one brake shoe has overlapped the outer edge of wheel tread from one-quarter of an inch to one inch, while the opposite shoe on the same beam is drawn hard against the wheel flange, and in this is doing infinitely more injury to flange than if the length of brake beam were from one-half to three-quarters of an inch shorter, besides reducing the co-efficient of brake shoe friction, due to reduced area of contact with one wheel.

"The loss of serviceable brake shoe material not worn off and returned to foundry as scrap; the greater tendency for cracked and broken wheels due to more rapid heating of reduced area of wheel tread in contact with brake shoe; the increased lateral strain on brake heads tending to loosen attachment with beams and also the premature destruction of brake heads on both ends of beams; the rapid wear of guide pins on outside hung beams, etc.

"These conditions found in service cause the committee to recommend that the length of brake beams for standard gauge cars be not less than 59¾ inches, and not more than 60 inches from centers of brake heads.

"The committee strongly endorse the Master Car Builders' standard height of beams, namely, 14½ inches from top of rail to center of brake shoes for outside hung and 13 inches for inside hung beams on 33-inch wheels, but that these heights be made for cars loaded to capacity as near as can be made by calculating the compression of springs, etc.

"It is important that the center line of brake hangers be made 90 degrees from a line drawn through center of brake shoe and center of wheel when the brake shoe is about one-half worn

out, in order that the strain imposed on hangers due to brake shoe friction will be as closely as possible in direct line of hangers to avoid the tendency of chattering of shoes on wheels, as well as adding to or detracting from the calculated brake shoe pressure. For the same reason, all brake beam hangers should be of liberal length, which is always more difficult to attain with inside-hung brakes, but is none the less important.

"The brake hangers should also have a close fit in attachment with brake heads, as well as in upper end support, to avoid the beams chattering from this cause as well as to impose destructive strains on beams and attachments, skidding wheels, etc.

"Brake beam hangers should engage the brake heads as close to brake shoe face in contact with wheel as possible to reduce the rotative influence of shoes and heads, due to shoe friction on wheels resisted by the brake hangers, thereby wearing the shoes more rapidly at the upper or lower end, being dependent on the direction in which the wheels rotate.

"It is obvious that to obtain equal distribution of load over entire brake shoe surface, the line of force transmitted from lever through brake beam must be to the center line of brake shoe and the brake beam hanger to be in direct line with shoe contact on wheel.

"The latter, however, under present mode of suspension, is quite out of the question, but should be approached as closely as conditions will permit.

"The brake heads should be of such construction and attached to beams at an angle that will leave beam and lever fulcrum (jaw) in a horizontal position when shoes of uniform thickness on both ends bear solidly against the wheel. This will of necessity require two patterns of brake heads, for inside and outside-hung brakes, owing to the variation in standard heights.

"It is a deplorable fact that many new freight cars, that in all other respects are of modern design, have brake beams suspended at heights greatly at variance with M. C. B. standards, and for which the brake heads were constructed, by which means the line of force is, to more or less extent, applied transversely to the web or truss in beams, thereby greatly reducing the endurance of beams."

Regarding the "scrap heap test" of brake beams, the committee says:

"The continually increasing numbers of broken and distorted brake beams in evidence in the repair shop and scrap heap, lead to but one conclusion, namely: First, that the average brake beam designed to meet the M. C. B. standard test of 7,500 pounds load, is no longer adequate for the modern heavy capacity freight car of to-day, more especially

GINSENG Fortunes in this plant. Easily grown. Roots and seeds for sale. Room in your garden. Plant in Fall. Booklet and Magazine 4c. OZARK GINSENG CO., DEPT. Y-15, JOPLIN, MO.

on heavy grades. Second, that the line of pull is too frequently diverted from that for which the beams were designed.

"The fact that not only has the light weight of freight cars increased to some extent, but also that the percentage of load-carrying capacity to the light weight is greatly increased in cars of modern construction, justifies the belief that all brake beams should be capable of enduring the M. C. B. test of 15,000 pounds for all cars of 80,000 pounds capacity and over.

"Investigation has developed that the M. C. B. standard turned pins are used quite generally on cars of recent construction, but the holes in levers and lever jaws are frequently found to have been drilled with flat drills, consequently are more or less out of true (not round), and are generally larger than standard and, what is still more deplorable, these holes are sometimes found to be punched, which practice cannot be too harshly condemned. All pin holes should be formed to standard size by the use of twist drills, or the equivalent.

"When brake cylinders of larger than 8-inch diameter are used on freight cars, we would recommend that these be of the detached type, having lever jaw on pressure head, to which the floating cylinder lever should be attached, thereby reciprocating piston power and eliminating this strain from cylinder support. However, if floating lever cannot be so connected with cylinder head, better results are obtained from the use of connected auxiliary and brake cylinder type of brake. Brake cylinders and auxiliary reservoirs should be securely bolted to metal plates, and the latter bolted or riveted to the underframing of cars. The bolts fastening brake cylinder to metal plate should be provided with cotter pins or double nuts, or both. By the use of wood blocks for attaching these parts to car framing, loose attachments are inevitably the result, owing to shrinkage of the wood."

After considerable discussion, in which those taking part endorsed the recommendations of Mr. Hedendahl, the paper was accepted and the discussion closed.

STENCILING OF BRAKE CYLINDERS.

The topical discussion on this subject was taken up and duly discussed. A committee headed by T. L. Burton, of the Central Railroad of New Jersey, was appointed to report on this subject. Their report recommended that the raised cast letters on the sides of the brake cylinder and auxiliary reservoir be eliminated, thereby giving room for stenciling, which would not only record the date of cleaning and testing, but that the name of the place at which the work was done and the name of the

person performing the same could be placed thereon.

The convention adjourned at one o'clock for lunch and to prepare for a trip to the West Seneca testing yard of the Lake Shore Railroad.

During the morning and afternoon the committee on arrangements and entertainment treated the ladies to automobile rides about the city.

A dance was given by the hotel proprietor to the convention people, in which a large majority took part and were entertained until a late hour. Mr. W. J. Courtney, of the Peerless Rubber Company, made each lady happy with a present of fine, long stemmed, American Beauty roses.

SECOND DAY'S CONVENTION.

The second day's convention was called to order by President E. G. Desoe in the chair.

HIGHER TRAIN PIPE PRESSURE FOR PASSENGER TRAIN SERVICE.

The first paper to be read and discussed was on the above subject and was presented by Mr. J. P. Kelly, New York Air Brake Company, Watertown, N. Y. The paper reflected careful and studied effort in its composition and did much credit to the author. However, the discussion which followed the reading of the paper was one of personal opinion rather than one of experience, inasmuch that few men present had had the experience in the matters treated that Mr. Kelly had. Many valuable and instructive features were brought out in the paper.

Mr. Kelly urged that the standard of 90 lbs. train line pressure be employed on such trains as were equipped with foundation brake gear sufficiently strong to stand such pressure, and which was not strong enough to withstand the stresses of 110 lbs. high speed pressure. He referred frequently to the results of the Atsion brake trials on the Central Railroad of New Jersey last May, and withal the paper contained much instructive and historic information.

The second part of the paper thoroughly discussed and advocated the adoption of the practice of holding the full brake cylinder pressure from the time of application to the time that the trains came to a standstill; the argument therefor being based on the high speed brake trials before mentioned, which showed that stops had been made with terminal pressures of 77 and 78 lbs. in the brake cylinders.

Mr. Kelly concluded his paper as follows:

"To sum up, we find that conditions to-day are such as to permit the use of 90 lbs. train pipe pressure in passenger train service without any additional appliances being used. We find our locomotives equipped with engine truck and

Besides **ASHTON** LOCOMOTIVE STEAM GAGES



WE MAKE

Duplex Air Gages
Gage Testers
Blow-off Valves
Chime Steam Whistles
Pop Valves

ALL OF A SUPERIOR QUALITY

Catalogue L on Application

The Ashton Valve Company, 271 Franklin Street, Boston, Mass.

**American Locomotive
Sander Company**

13th & Willow Sts., Philadelphia, Pa.

Proprietors and Manufacturers,

LEACH, SHERBURNE, DEAN, SANDERS
HOUSTON, "SEE" and CURTIS

"SLIGO" IRON

The Standard for Eighty Years

for

DUCTILITY and TOUGHNESS

Staybolts

Unexcelled for **Piston Rods**

Crank Pins

AND DIFFICULT FORGINGS

SLIGO IRON & STEEL CO.

Successor to Phillips, Nimick & Co.

PITTSBURGH, PA.

**The Union
Switch &
Signal Co.**

**Consulting and Manufacturing
Signal Engineers.**

**GENERAL OFFICES AND WORKS AT
SWISSVALE, PA.**

DISTRICT OFFICES:

New York: Central Building, 143
Liberty Street.

Chicago: 1536 Monadnock Building.
St. Louis: Terminal Station.

THE ROBERT W. HUNT & CO.

Bureau of Inspection, Tests and Consultation,
1137 THE ROOKERY, CHICAGO.

66 Broadway, New York. Park Building, Pittsburgh.
31 Norfolk House, London, Eng.

Inspection of Steel Rails, Splice Bars, Railroad Cars,
Wheels, Axles, etc. CHEMICAL LABORATORY—Analysis
of Ores, Iron, Steel, Oils, Water, etc. PHYSICAL LABO-
RATORY—Test of Metals, Drop and Pulling Test of Coup-
lers, Draw Bars, etc.

Efficiency Tests of Boilers, Engines and Locomotives.

Bargain Book Sale

SKEEVERS' OBJECT LESSONS

BY JOHN A. HILL

A collection of the famous Object Lessons which appeared in this paper several years ago. They are interesting, laughable, and best of all are of practical value. Cloth bound..... \$1.00

CARE AND MANAGEMENT OF LOCOMOTIVE BOILERS

The best book on this subject that we know of. Also contains several chapters on oil burning locomotives and gives actual practice in the Southwest. Price50

Compound Locomotive (The). Compiled by Fred H. Colvin. A convenient size pocketbook for the practical engineer or mechanic who wishes to become familiar with the different types of American compound locomotives. Tells all about operation, repairs and breakdowns of different types. Fully illustrated Bound in leather 1.00

SHOP TALKS, By ICHABOD PODUNK, is another book which any mechanic needs. It tells in humorous vein the experience of a machinist with different foremen, and is valuable to any one in charge of men. Flexible cloth..... .50

\$3.00

All sent on receipt of **\$1.50**

ANGUS SINCLAIR CO.

174 Broadway, NEW YORK

CONTENTS.

	PAGE.
Air Brake Department.....	267
*Brake, Duplex Straight Air and Automatic	269
Cars, Unbraked Weight of.....	270
*Convention, Air Brake.....	267
*Boilers, Designing of Locomotive. By Roger Atkinson	274
Book Reviews	284
Car, *Old Wooden Rockersill.....	248
*Vanderbilt Steel Flat.....	276
Convention, Master Mechanics'.....	259
*Cylinders, Top Wear of.....	257
Editorial	259
Experiments, Requests that Master Mechanics' Assn. Pay for.....	261
Experts, Air Brake Association.....	262
Fellow Servant Law, Supreme Court Upholds.....	262
*Fuel Economizer	255
General Correspondence	255
Grade Crossings.....	258
Heat, Critical, of Steel.....	261
*Locomotive—	
Baldwin 4-6-2 for R. F. & P.....	281
De Glehn Compound for Pennsylvania.....	245
General Electric, New York Central Electric	286
Growth of the, by Angus Sinclair.....	263
Mallet Articulated Compound for B. & O.....	253
N. Y. C. & H. R. R. R., 4 Cylinder Compound	272
New Zealand	258
Rogers Mogul for St. Louis Southwestern.....	247
4-6-0 for Great Western of England.....	251
Locomotives—Slipping Shut Off.....	256
Tests for Compound.....	256
Locate Blows on Tandem Compound.....	281
Machine Tool—	
*Taylor-Newhold Cold Metal Saw.....	280
Management, Non-Political, of State Owned Railways	250
Metals, Drilling Hard.....	257
Personals	277
Photography, Railroad.....	255
Questions Answered	262
Rail, Creeping of.....	273
Railways, *British North Borneo.....	249
Cuban	246
Non-Political Management of State Owned Roundhouses, Square.....	285
Signals and Signaling, by Geo. S. Hodgins.....	252
Steel, Critical Heat of.....	261
*Truck, Equalized, Tender.....	282

driver brakes; tender brakes; and the cars in our trains have brakes applied to every wheel. We no longer, as a rule, find passenger trains made up of cars having six wheel trucks and brakes operating on only two pairs of wheels in each truck; nor locomotives in service with driver brakes cut out, and no brakes whatever on the engine truck.

"Our tender brakes are not yet all that they should be, but, from the increasing weights of tenders and their capacity for holding water, their brakes will, in the future, have to be kept up in much better condition than they have been in the past, or wheel sliding will result to a more or less extent.

"With modern equipment, having the foundation brake gear throughout the whole train of modern design and ample strength, a train pipe pressure of 110 lbs. should be used, and in the service application an automatic pressure reducing valve may be used with benefit. This is because service applications are made under varying conditions of rail and grade, etc., but, in the emergency application the practice of blowing down brake cylinder pressure should be discontinued for the reason that the only thing to be gained by the reduction of brake cylinder pressure is the prevention of sliding wheels through a few feet at the end of the stop, while the gain we have from maintaining the maximum brake cylinder pressure throughout a stop, from high speed, is of so much benefit in shortening up the stop, lessening shocks when collision occurs, and, therefore, as a factor in the prevention of injury to passengers and equipment, that it far outweighs consideration of the wheels.

"It is a fact that a wheel sliding will not hold so well as one that is revolving while brakes are applied; but this is true only within certain limits, and these limits are so narrow that, in my opinion, they do not deserve any weighty consideration in connection with high speed passenger service."

The discussion on this paper was exceedingly interesting and instructive. The convention recommended that the matter of 90 lbs. train line pressure be adopted on roads where local conditions would permit the same, and where advantageous results would be had from its use. The second part of the paper which referred to the full retention of the brake cylinder pressure during the entire period of the stop was deemed of too great importance for the association to recommend at this stage of air brake art.

In connection with this paper Mr. F. M. Nellis presented a paper of kindred nature on the advisability of braking passenger equipment cars on a basis of specified dead weight per pair of wheels, instead of the 90 per cent. plan, which appears elsewhere in this department.

BETTER SELECTION AND PRESENTATION OF PAPERS FOR FUTURE AIR BRAKE CONVENTIONS.

The paper on the above subject was presented by Mr. F. M. Nellis. He endeavored to bring out the advisability of more papers being presented by individual authors, instead of committees which is the usual practice. The plea for individual papers was based on experience which showed that the committee, unless it was on some subject which required experiments to be made and the work of several members jointly, was a hindrance instead of an assistance. He mentioned that the individual papers of the present convention confirmed his belief in the matter and supported the paper presented.

RESPONSIBILITY FOR TORN OFF AIR HOSE.

The paper on the above subject was presented by Mr. F. B. Farmer, whose theme was based on the action of the Master Car Builders' Arbitration Committee, which inferred that pulling apart of the hose was the correct way of separating them and that the delivering company should not be held responsible for torn off hose. Mr. Farmer's paper thoroughly discussed the subject and showed the advisability and wrong practice in this matter as it encouraged carelessness in pulling hose apart when shifting cars and placed a premium on carelessness in this respect. The paper was referred to the committee which will attend the Master Car Builders' Convention in Saratoga in June.

Mr. F. W. Brazier, master car builder of the New York Central & Hudson River Railroad, also president of the Master Car Builders' Convention, then addressed the convention. In a neat and handsome speech he concisely and clearly stated the relation of the Air Brake Association to the larger associations and its responsibility.

Mr. Angus Sinclair, editor of LOCOMOTIVE ENGINEERING, addressed the association, encouraging it in its work and complimenting it upon its past performance. Together with Mr. Frazier he believed that the future high offices of the mechanical department in railways would be held by the present members of the Air Brake Association, inasmuch as they were working along the line of specialization and in the direction of future railway electrical developments.

During the afternoon, the men in a body visited the five air brake instruction cars which officials of the Lehigh Valley, New York Central, Ontario & Western, Intercolonial and Grand Trunk railways had cautiously sent to the convention.

In the evening these cars were handsomely illuminated and the convention ladies were escorted in a body to them and handsomely entertained.

(To be continued.)

Nine Acres
of
Floor Space



2½ Times
Larger than
Former Plant

NOTICE OF REMOVAL B. F. STURTEVANT CO.

The Entire Plant
From Jamaica Plain

TO HYDE PARK, MASS.

B. F. STURTEVANT CO., HYDE PARK, MASS.

Boston

New York

Philadelphia

Chicago

London

374

INDEX TO ADVERTISEMENTS.

Acme Machinery Co.....	Front Cover	Damascus Bronze Co.....	29	Niles-Bement-Pond Co.....	—
Acme White Lead and Color Works.....	10	Dart Mfg. Co.....	5	Niles Tool Co.....	—
Ajax Metal Co.....	4th Cover	Davis, John, Co.....	17	Norton Grinding Co.....	—
Allis-Chalmers Co.....	—	Detroit Lubricator Co.....	29	Norwalk Iron Works.....	6
American Balance Valve Co.....	4th Cover	Dixon, Joseph, Crucible Co.....	287	Ozark Ginseng Co.....	293
American Brake Shoe Co.....	3	Duff Mfg. Co.....	291	Pedrick & Ayer Co.....	—
American Loco. Sander Co.....	294	Eynon-Evaus Co.....	25	Peters, H. S.....	290
American Locomotive Co.....	30	Falls Hollow Stayholt Co.....	35	Pittsburgh Crushed Steel Co.....	4th Cover
American School of Correspondence.....	—	Fay & Egan Co., J. A.....	31	Pond Machine Tool Co., The.....	—
American Steam Gauge & Valve Mfg. Co.....	6	Flanders, L. B., Machine Works.....	3	Porter, H. K., & Co.....	34
American Steam Packing Co.....	15	Flannery Bolt Co.....	15	Pratt & Whitney Co.....	9
American Valve & Meter Co.....	292	Franklin Mfg. Co.....	5	Pressed Steel Car Co.....	33
Armstrong Bros. Tool Co.....	20	Galena Signal Oil Co.....	5	Prosser, Thos., & Son.....	8
Armstrong Mfg. Co.....	35	General Electric Co.....	22	Protectus, The.....	3
Ashcroft Mfg. Co.....	—	Gold Car Heating Co.....	—	Railway Appliances Co.....	291
Ashton Valve Co.....	294	Goodrich Rubber Co.....	15	Railway Materials Co.....	21 Cover
Automobile Magazine.....	20	Gould Coupler Co.....	15	Rand Drill Co.....	14
Baker, Wm. C.....	5	Gould & Eberhardt.....	4th Cover	Revere Rubber Co.....	11
Baldwin Locomotive Works.....	32	Griffin & Winters.....	293	Rogers Locomotive Works.....	34
Ball, Webb C. Watch Co.....	291	Hammett, H. G.....	4th Cover	Ross Valve Co.....	4th Cover
Barnett, G. & H., Co.....	2d Cover	Hancock Inspirator Co.....	11	Rue Mfg. Co.....	25
Becker-Brainard Milling Mch. Co.....	—	Haady Car Equipment Co.....	290	Safety Car Heating & Lighting Co.....	21
Bettendorf Axle Co.....	2d Cover	Hayden & Derby Mfg. Co.....	—	Saunders' D., Sons.....	6
Big Four Railroad.....	25	Hendrick Mfg. Co.....	6	Seaboard Steel Casting Co.....	20
Compound Locomotives.....	—	Henley, N. W., & Co.....	19	Sellers, Wm., & Co., Inc.....	16
Computers.....	196	Hicks, F. M.....	4th Cover	Shaw Electric Crane Co.....	—
Firing Locomotives.....	4th Cover	Hoffman, Geo. W.....	6	Sligo Iron & Steel Co.....	294
Handling Locomotives.....	—	Hunt, Robert W., & Co.....	294	Smooth-on Mfg. Co.....	290
Locomotive Running and Management.....	25	Illinois Central R. R.....	6	Southern Pacific R. R.....	291 & 8
Miscellaneous.....	12	International Correspondence Schools.....	23	Standard Car Truck Co.....	17
Oil Burning in Locomotives.....	—	Jenkins Bros.....	4th Cover	Standard Coupler Co.....	3
The American Locomotive.....	4	Jones & Lamson Machine Co.....	291	Standard Paint Co.....	—
Twentieth Century Locomotives.....	4	Kennicott Water Softener Co.....	13	Standard Steel Works.....	25
Boston & Albany R. R.....	17	Lackawanna R. R.....	35	Standard Tool Co.....	17
Boston & Maine R. R.....	25	Laidlaw-Dunn-Gordon Co.....	292	Stannard & White.....	292
Brady Brass Co.....	3	Lake Shore R. R.....	25	Star Brass Mfg. Co.....	16
Buker & Carr Mfg. Co.....	—	Latrobe Steel Co.....	—	Starrett Co., L. S.....	23
Campbell, A. S.....	—	Latrobe Steel & Coupler Co.....	35	Sturtevant, B. F., Co.....	296
Carborundum Co.....	8	Lawson Car Co.....	36	Tabor Mfg. Co.....	16
Carpenter, The J. M. Tap & Die Co.....	17	Link Model.....	9	Thompson, C. A.....	6
Central R. R. of New Jersey.....	25	Locomotive Chart.....	2	Underwood, H. B., & Co.....	3
Chapman Jack Co.....	2d Cover	Locomotive Firemen's Magazine.....	26	Union Pacific R. R.....	4
Chicago & Alton R. R.....	17	Locomotive Publishing Co., Ltd.....	4	Union Switch & Signal Co.....	294
Cleveland City Forge & Iron Co.....	4th Cover	Lodge & Shipley Machine Tool Co.....	18	United States Metallic Packing Co.....	29
Cleveland Punch & Shear Works Co.....	15	Lucky Locomotive Stoker Co.....	23	Utica Steam Gauge Co.....	—
Cleveland Twist Drill Co.....	4th Cover	McCormack & Torley Co.....	24	Valve Model.....	2
Cling Surface Mfg. Co.....	293	McCord & Co.....	290	Vitrified Wheel Co.....	4th Cover
Commonwealth Steel Co.....	27	Manning, Maxwell & Moore.....	—	Wachter Mfg. Co.....	288
Consolidated Railway Electric Lighting & Equipment Co.....	31	Middletown Car Works.....	5	Walworth Mfg. Co.....	2d Cover
Consolidated Safety Valve Co.....	—	Miller, Thornburgh & Co.....	1	Watson-Stillman Co.....	4th Cover
Crandall Packing Co.....	289	Miner, W. H., Co.....	2d Cover	Westinghouse Air-Brake Co.....	28
Crane Co.....	8	Nathan Mfg. Co.....	6	Westinghouse Electric & Mfg. Co.....	29
Crosby Steam Gauge & Valve Co.....	34	National Malleable Castings Co.....	4th Cover	Whitelsey, Geo. P.....	4th Cover
		Nicholson, W. H., & Co.....	290	Wiley, J., & Sons.....	292
				Wood, R. D., & Co.....	2d Cover

Railway and Locomotive Engineering

Copyright by Angus Sinclair Co.—1904

A Practical Journal of Railway Motive Power and Rolling Stock

Vol. XVII.

174 Broadway, New York, July, 1904

No. 7

Horse Power.

A horse power is 33,000 foot pounds per minute, or, in other words, 33,000 pounds lifted one foot in one minute, or one pound lifted 33,000 feet in one

out of use, and is merely a conventional mode of describing the dimensions of a steam engine for the convenience of makers and purchasers of engines. The mode of computing the so-called nomi-

the mean effective pressure to be seven pounds per square inch. From these fictitious data and the area of the piston compute the horse power; that is, nominal horse power $= \frac{7}{128} \sqrt{\text{stroke}}$



KENILWORTH CASTLE FROM THE BRIDGE—LONDON AND NORTH WESTERN RAILWAY.

minute, or 550 pounds lifted one foot in one second, etc. The capacity for work of a steam engine is expressed in the number of horse powers it is capable of developing. Nominal horse power is an expression which is gradually going

nal horse power was established by the practice of some of the early English manufacturers, and is as follows: Assume the velocity of the piston to be 128 feet per minute multiplied by the cube root of length of stroke in feet. Assume

in feet \times area of piston in square inches $\div 33,000$.

Indicated horse power is the true measure of the work done within the cylinder of a steam engine, and is based upon no assumptions. It is actually calcu-

lated. The data necessary are: The diameter of the cylinder in inches, length in feet, the mean effective pressure and number of revolutions per minute. As we have before stated, or implied, work is force acting through space, and a horse power is the amount of work in a specified time. In a steam engine the force which acts is the product of the area of the piston in square inches multiplied by the mean effective pressure; the space is twice the stroke in feet, or one complete revolution, multiplied by the number of revolutions per minute. Therefore, indicated horse power equals the area of the piston, multiplied by the mean effective pressure, multiplied by the piston speed in feet per minute divided by 33,000.

Effective horse power is the amount of work which an engine is capable of performing, and is the difference between indicated horse power and the horse power required to drive the engine when it is running unloaded. Engine rating, guarantees, etc., are usually based upon the indicated horse power, owing to the ease and accuracy with which it can be determined, and as a means of comparison. Nominal horse power is computed from fictitious data. Indicated horse power is computed from actual data, which is arrived at by means of what is known as the steam engine indicator. Effective horse power is computed from actual data, either by means of the indicator, brake or dynamometer.

H. H. Vreeland on Electric Roundhouses.

At the May meeting of the New York Railroad Club a paper on Roundhouse Foremen was read and discussed. At the finish President Vreeland said:

Having had experience in connection with the subject that you gentlemen are discussing from the motive power standpoint, I might say: Wait until you get into electricity. The troubles in connection with roundhouse work electrically, are very much greater than anything that goes with the motive power proposition. You have fifty years or sixty years of scientific development and experience back of you to draw on for any character of work. The electrical development, of only the other day, is here, and if you have two thousand cars, each one of them is a locomotive so far as the intricate electrical parts are concerned. The foreman of an electrical house—call him the roundhouse foreman, if you please, his duties are practically the same—has not back of him the experience of the steam roundhouse foreman as a guide. You have a skilled and experienced man handling the machine, who makes his report of defects. The electrical roundhouse foreman has merely a runner who is educated to operate the car. He

knows very little about the electrical or mechanical principles of operation; very few reports are made by him. The result is that if a man has 400 or 500 cars lying at the house he has to have the technical ability himself, and the technical ability in connection with his subordinates, that can determine the delicate workings of controllers, motors, armatures, commutators, field coils, circuit breakers, and resistance coils—the circuit breaker acting as a safety valve, very delicate in adjustment, extremely easy to get out of order, and if out of order resulting in the burning out of the resistance or the burning out of the motors or possibly the controller in connection with the car movement. Amplify that to the extent of each car in itself, less the generation of the motive power, having all the intricate mechanical workings of a locomotive, and you see what we are up against in that proposition with only the short experience of a few years back of us to draw on for a class of men to do this work.

While the principle is the same, as you progress in the size of your equipment, at the same time it becomes more intricate in its workings as you increase the voltage or amperage under which you are working. There have been a number of very delicate experiments made the last few months in connection with electrical operation to determine what were the underlying faults that could be corrected through what we class our division work organization, being exactly the same as your organization. The main machine shop and electrical shop receive the car, and its electrical equipment, that is not capable of repair by what you might term the roundhouse force, paralleling yours. The slightest out-of-adjustment on circuit breakers which can be occasioned by the least bit of dampness, dust and so on—the circuit breaker not working the minute that it should—results either in the burning out of the resistance, or the entire disabling of the electrical equipment of the car, rendering it useless until it has gone through the main machine shop again.

The question of men to handle that work is a serious problem with the electrical roads. It will become on a much larger scale a more serious problem, for you men that have to do with steam roads, as you progress in the system of electrical operation to meet your requirements. The greatest difficulty we have to-day in connection with our operation—given that we require just as much technical, managerial and executive ability on the part of roundhouse foreman as you do—if you have a roundhouse with 500 engines, and as we have many houses with 500 cars, you can see that it becomes a pretty serious question, and I may say it has not been

a question of wages, is the difficulty in securing competent men, by reason of the limited experience that necessarily could be gathered in the short interval in which this great electrical development has taken place. It has been almost impossible to secure the type of men required.

As I said at the outset, with what I understand of the troubles in connection with your operation in that respect, I will give you the solace of considering how much they will be amplified when you go into the question of electrical operation. (Applause.)

The Value of Heating Surface.

It is well known that a square foot of heating surface in one part of a boiler is not necessarily as efficient as at another. This is peculiarly true of flue heating surface, as was brought out in Mr. H. H. Vaughan's paper recently read before the Western Railway Club.

Speaking of experiments made to determine the relative efficiency of portions of flues close to and remote from the fire box, he says, an account can be found in D. K. Clark's "Steam Engine": "Without going into an extended description, a boiler having a grate area of 9 sq. ft., fire box heating surface 60.28, and 125 tubes $1\frac{7}{8}$ ins. diameter, 12 ft. 4 ins. long, had the tubes divided into four sections each 3.01 ft. long, leaving $3\frac{1}{2}$ ins. of tubes attached to the fire box, forming the 5th section. Test was carried out with coke and with briquettes, the former of which may, I think, be neglected. With briquettes coal was burnt up to 113 lbs. per square foot of grate per hour, which is a fairly high rate of combustion. Tests were also made with one-half of the flues stopped off."

In this case, he tells us, the evaporation per square foot from a flue of any length would be the same if the square root of the tube were taken in place of the actual length. On this basis the experiment showed that the second section did more than the first and third, and the fourth less. In other words, the most effective part of the flue is not that actually next to the flue sheet, but is a short distance from it.

Flame Temperatures.

M. Féry writing in *Comptes Rendus*, gives several interesting flame temperatures. The centigrade thermometer has been used by the experimenter, but we give them in terms of Fahrenheit degrees for our readers.

The temperature of a Bunsen burner fully aired, is 3,399° F.; Bunsen burner, partly aired, 3,293° F.; Bunsen burner, not aired, 3,113° F.; acetylene burner, 4,618° F.; alcohol, free flame, 3,101° F.; hydrogen, free flame in air, 3,452° F.; oxy-coal gas blow pipe, 3,992° F.; oxy-hydrogen blow pipe, 4,388° F.

Technical Education in Russian Asia.
BY L. LODIAN.

What has been done by private effort in America so much during the past decade—the founding of technical correspondence schools—is accomplished by the Russian state in Cibiria—the establishing of technological institutes at towns like Tomck (western Cibiria) and Ipkytck (central Cibiria). The older in-

stitutions at Mockba and Peterburg were too distant for the Cibiriak student to reach. Tomck possesses the most important technological school thus far established in Cibiria. It is a solidly-built three-main-floor edifice of the buff or ochre-brown sandstone procurable east of the Ural range, and the cross-Cibirian tourist would little expect to see so advanced an edifice among towns whose buildings are built chiefly of crudely-mortised tree-lengths. (Frame or board houses would be too thin to keep out the 40° to 50° below Cibirian cold.)

It is a peculiar feature of paternal government in Russia, that the students of the different state technical schools and institutes are, every summer, divided up and distributed among the different engineers in government employ. This is for the annual *npaktika* ("practice"). The period ranges from six weeks to a couple of months. They are quartered on the engineers and "billeted" without a kopek of recompense to the latter, who, moreover, are expected to house them well, "as one of the family," and to advance their working training and knowledge "to the limit." The engineer almost has to take them in *volens volens*. True, he is written to, first of all, by the respective authority, inquiring if it would be acceptable to him to receive the help of a student for his summer detail, and he knows what might "happen" if he declined. He was quartered himself, when young, on other engineers; so he

must now be prepared to have others billeted on him for a succession of summers. Still, there are some who can "safely" refuse. However, the railroad student thus gratuitously thrust on to the hospitality of a division engineer, or of a "shop's" or "work's" chief, understands his somewhat delicate position, and usually has the tact, education, and breeding, to make himself

proper intrinsic value—as a sheet of stout paper, at about one-eighth of a cent; and the bedecked uniform he would simply reckon as "not in it."

ters—which, of course, requires a wife to look after it. So you see the gratuitous infliction by the government of railroad students on the older engineers has at least some interesting advantages—and, later, "additions." If the student elects, he can be quartered on a relative engineer, or on any other chief to whom he knows his presence and help will be acceptable. Some "repeat" every summer with the same "nachalnik" during their studentship, although this is recognized as not advisable, as not offering sufficient variation of practice. One summer with a division engineer, another with a works engineer (repair shops), a third in locomotive driving, a fourth in bridge practice, a fifth with the controlling engineer (the individual who, in Cibiria and Russia, is supposed to guardian the probity of other engineers, but who has to be sharply watched or "controlled" himself, to keep him honest)—this, and other items, is the diversity of practice deemed best for the future railroad engineer in Russiadom.

"NOBLE BIRTH AND UNIFORMS MAKE THE ENGINEER."

Going and returning, the railroad student is always supplied with passes by the institutes (second class). These annual summer "practices" continue for five or more years, till the student receives his diploma, which is everything in Russia, along with the uniform: for here "the uniform proclaims the man." The hard-working shirt-sleeves American railroad manager, with practical experience from plate-layer to superintendent, would value that "diploma" on its face at its



Gendje print, Ob, Chbp.

THE STATION OF CENTRAL CIBIRIA.

a real help to the engineer, and acceptable to the household. Many of the "nachalniki distancja" (lit., nachalniks, or chiefs, of distance)—as division engineers are there termed—are of course located in remote country or mountainous districts, with very scant society of and kind; and, to such, the yearly advent of the "student" from Mockba or Peter-

burg is often quite acceptable—if for the sake of a little society alone.

From these yearly visits, many lasting friendships have sprung up, the student (arrived at the paper-diploma stage) sometimes marrying into the family which contributed to his training, on his receiving a "nachalnik" post for himself, with the accompanying free-house quar-



Nachalnik etanefa, Chpemochniki.

STATION CHEPEMOCHNIKI ON THE TRANS-CIBIRIAN R. R. NOTE THE CHEVAUX-DE-FRISE WORK ON THE GRADING TILL THE BANK SOLIDIFIES AND BECOMES GRASS-COVERED.

ter proper intrinsic value—as a sheet of stout paper, at about one-eighth of a cent; and the bedecked uniform he would simply reckon as "not in it."

I have had Russian engineers say to me something like this: "I would like to go to America, where engineers are so much better paid than here." He was receiving 120 rubli monthly—equal to lit-

tle over \$60 American, but its purchasing power under \$50 of our money. "Now, here are my diplomas," he went on, pointing to two framed parchments on the walls, "and I am of noble birth. My grandfather's father was the great prince who fought against Napoleon at Borodino—yes, he was the grand chief General Popemoff. My mother is also of noble birth. Her grandmother was 'kniarinia' (princess) Slobberslouskiol, and —;" and so on.

little party before they leave. Tents, bedding, supplies, cuisine articles, etc., are furnished by the state; also two or three mujiks for the menial work of the camp.

In Cibiria, during the short summer, the tyros experience a range of daily temperature almost amusing in its eccentricity—from needing shade-umbrellas for shelter from the fierce afternoon sun's rays to, in three or four hours, heavy overcoats for protection from the

the biggest lake in Asia, on location work for the circum-Baikal line.

Since Manchuria is much in the "public eye" just now, I would, in passing, remark that as the result of prolonged personal observations and intercourse with Russians on the spot, Russia never intends, and never did intend, to "clear out" of Manchuria. Manchuria is a vital "geograficheski necesité" for Russia—the military officers and engineers on the spot will, to a unit, assure you. And I used to notice below, on the official reconnaissance charts prepared by the different corps which penetrated Mongolia and Manchuria, under the guise of "icizkantie" (location work) for the trans-Manchurian, not alone was all territory east of the now-operating railroad, colored green (the official color for Russian territory), but for hundreds of miles to the west of it—way into the deserts of Mongolia—was the same tinting conspicuous.

HOW POSITIONS ARE OBTAINED IN RUSSIA-
DOM.

Graded with the rank of "injener nytei-coobchehia" (lit., engineer way-communications)—as railroad engineers are officially designated in Russia—the former student enters his name, for an appointment, with the respective department. He gets a position valuing according to the strength of his purse. Bribery pure and simple does not exist in Russia—of course not! Nor does it in America! The trick, in its most common and least objectionable form, is done in Russia by, at a little card-play, "losing" a few hundred—or thousand—rubles to your "protector."



C. Pen. print, Rejoni-Yol'nek.

MONGOLIAN LADIES OF HIGH DEGREE.

He was advised, if going to America, to leave his titles behind—it would be less cumbersome "haggage;" and not to produce his diplomas till they were asked for. I gave him this advice, to spare him the humiliation, if ever in America looking for work, of sitting out an amused general manager's smile when the paper-diploma and "noble birth" commodities were trundled out, hoping to secure favor on the strength of such a "pull."

* * *

Oftimes, where new location work is in progress, and within reasonable distance—as distances go in Cibiria and Russia—of the technical institute or college, the students are drafted in batches of from a dozen to a score, and the different groups detailed to aid the regular corps of engineers engaged in "icizkantie" (surveying and location). I am giving some of the Russian technical words, rendered into the nearest equivalent in English characters, to show what (in the vulgar but effective speech of the mining engineer) a "gut-splitting" idiom is this language of the land of Tolstoi. Thus they are at once brought face to face with real practice and the "ruf-and-tuf" life of railroad engineering details on the swampy *cten* and amid the mosquito-plagued taira (forest). All being young and new to it, the older engineers find them more willing and serviceable than hired men of the locality.

When thus engaged, the students form camp distinct from the engineers, although, of course, always in proximity. One of their number is appointed by the school or institute authorities, chief of the

chilling night winds. Some of the mornings the latter end of August, the water left over night in the bucket in your tent is frozen solid by dawn.

Sometimes, again, two or three students will be detailed to help at a distant bridge in a sparsely-habited region. As there is no accommodation for them, the railroad furnishes an old coach or freight car, about half the length of our own cars; it is jacked-off

onto a temporarily-made siding, a stove is put in, and the young party, with their kit, are left to shift for themselves for a couple of months.

PRACTICE IN MANCHURIA.

Companies of students are also sent for practice on quite long-distance trips to the Trans-Baikal, and even to Manchuria. The writer has put up with them in their tents on the za-Baikal, and on the spurs of the Altai range circumventing the southwest end of this

So strongly is this financial "influencing" implanted into the Russian character, that ministers even are powerless against it.

A bankrupt country like Russia cannot afford to pay good salaries to railroaders. All are poorly paid. Fancy a division engineer having to be content with—equal to—\$60 per month! A locomotive engineer, at the maximum mileage, will turn 100 rubles—a trifle over \$50. A station-chief will average



Canyel Pen. print, Ekatep'inlyov.

MONGOLIAN MONASTERY STUDENTS.

50 roubles. Roadmaster, 30 roubles (\$15). Track, 20 roubles (or \$10). And so on—a doleful list of barely-to-exist “wages.” All salaries are paid monthly. Then, in each case, the purchasing power of—equal to—\$50 in Russia is less than in America.

Is it any wonder, then, that officials go “on the make” as a matter of course?

It is under these not-reassuring conditions—a verging-on-bankruptcy empire, poor wages, influence and favoritism always taking precedence of merit, the masses more than nine-tenths wholly illiterate, the most wasteful form of government on earth, and its results the poorest—that the young Russian railroad students are developing. The outlook is not bright. I had heretofore thought, during travels in old Hispania, that España was the most backward nation of Europe; but Russia “takes the record” now!

And, worse still, there is no prospect of affairs improving. It is doubtful if a single department of the government shows an economical profit—except the tax-gatherer and the gin-seller (the national ardent spirit, vodka, now being controlled by state monopoly).

The student in Cibiria, again, is handicapped, like the older engineers, by an unavoidable ignorance of modern railroad construction engineering and improved shops-machinery. Although labor was so scarce for the construction of the trans-Cibirian, not a single steam-shovel was in use along the entire route; hand-labor did everything. Yet, the Russian ministry spent big sums sending railroad engineers especially to the United States to report on American railroad-building equipment.

A few American machinery catalogues in engineers’ hands in Cibiria would tell them something they didn’t

throughout Cibiria. They seldom see, yet thirst for, catalogues of mechanics, and preserve them more than bibles. I

there, the boarding houses being surrounded by a high stone wall to prevent said boarders straying away and



D. Cliff, print, Kokyl, Baikal

TYPE OF ENGINE HOUSE, CENTRAL CIBIRIA

mention this to enlighten firms who may in a few weeks be receiving inquiries mentioning this journal in far Cibiria.

Old Time Railroad Reminiscences.

BY S. J. KIDDER.

If Tom Tucker’s engine hadn’t gone into the shop for an overhauling and I been taken from the main line and put on his Keokuk branch run I wouldn’t have been arrested for fast running within the limits of a little city whose

left to their own resources until their term of sentence had expired by limitation.

Now, I did not object to getting down on the branch occasionally, for after hammering away month after month on the heavy main line runs, a few weeks on the branch with but three or four cars for a train proved a veritable picnic, so far as hard work was concerned and served as a sort of recreation and lay off combined without the formality of taking a vacation. To be sure the track was not of the best, particularly at the south end, where several miles of old 17 ft. iron rails were badly worn, their ends supported on cast iron chairs, were still in use, requiring a speed hardly commensurate to that necessary to make time in safety. As a consequence the ordinances of several towns limiting speed to six miles per hour were ignored with somewhat reckless abandon, these pieces of track being utilized to make up time sacrificed at other places.

Again, these river towns were long, slim and slender, stretching along the bank of the Mississippi and as the right of way followed the contour of the stream a six mile an hour gait could hardly be literally lived up to and permit fulfilling the schedule requirements.

Fort Madison was the worst drawback of all, for it stretched along the river some two miles, and as the track coursed along the river bank with a retaining wall several feet in height on the city side, there



C. Pen, print, Ekatepik.

GENERAL VIEW STATION OB, CENTRAL CIBIRIA.

know. I have suggested to the publisher sending a few score copies of this issue to representative railway chiefs

chief industry at the time was the taking care of several hundred compulsory guests whom the State of Iowa had sent

was little to prevent good speed or promote danger, excepting that six mile an hour ordinance. The inhabitants of this particular bailiwick were mostly of that slow, easy going character that frequently obtains in out of the way places and for years the boys had been dropping into and through town at a speed in marked contrast to that demanded by the ordinance, and time card rules as

"Fast running inside the city limits." said he.

"Well, here we are at your disposal."

"Hardly," he replied. "You have got too much United States mail in that baggage car and Uncle Sam don't allow any delays to his shipments. 'I'm no enemy to the C., B. & Q. boys.'" he continued, "but an old Dutchman up here in town has sworn out an informa-

local firm of attorneys, also retained by the road, would look after our interests when the hearing took place. The case was finally placed on the calendar and we were notified to appear on the following Friday.

The fatal day approached, though, if my memory serves me, it did not happen to be the 13th of the month, and taking the morning train as passengers, soon debarked therefrom at the Fort Madison station. Almost the first salutation received as we alighted was from the sheriff who, after a cordial greeting, gave us directions as to the location of the court house and time the court convened, together with other necessary information which we, as amateur criminals, stood much in need. While he was talking, in my mind's eye I could see a big gun, shackles and other appurtenances supposed to be an integral part of a well equipped sheriff, but as nothing of the kind was exhibited I fell to wondering when our arrest would begin and the nature of emotions produced when in such a predicament. He turned to walk away and I timidly inquired if we were under arrest, to which he replied, yes, but that he had some important business to attend to before court opened and would see us later. Left to our own resources we dropped into a neighboring hotel and were entertained by the landlord until about time to present ourselves before the justice who was to adjudicate our immediate future. On our way to the court room the conductor and myself stepped into the office of our attorneys and, upon canvassing the matter at issue, during which it was admitted by



H. Lenopinski, print, Tomsk.

FIRST ARRIVAL OF A TRAIN AT CIBIRIAN TOWN (TOMCK).

well, and as time went by with no apparent marks of disapproval the limit of speed had become a dead letter, if not quite forgotten. At last, however, the latent law exerted itself when the engineer and conductor of a Burlington & Southwestern freight which used the C., B. & Q. tracks through Fort Madison were summarily removed from their train, taken up town, given a speedy hearing and fined, which was paid without a protest.

One day not long after this incident Conductor Chatterton and myself made our usual run down the branch and on our return the same evening upon stopping at the station I picked up my oil can and got off the 245 with a view of looking for hot pins or boxes, which occasionally developed as a result of the sand ballast which lined the way. As I stepped from the gangway a gentleman was noticed standing beside the engine who, as I approached, threw back the lapel of his coat, displaying a large, brightly polished badge with star in the center, over which in black letters was the ominous word "Sheriff." Immediately following this display he smilingly said, "Good evening."

"Good evening," I replied.

"Did you go down on this train this morning?"

"I certainly did," said I.

"Well, I have got a warrant for the arrest of yourself and the conductor."

"What for, if I might be so bold as to inquire."

tion against you and the conductor and as sheriff I am compelled to serve it. You will have to come down for trial, the time of which I will advise you later."

Upon reaching Burlington my partner in crime and myself talked the matter over and in reply to his query what we had best do I replied, Nothing; that it was one thing to file an information



Lekbleki, print, Omck.

A CHURCH CAR ON THE CIBIRIAN R. R.

that we were running more than six miles an hour and quite another to prove it, and I proposed to stand trial.

We finally adjourned to the superintendent's office, acquainted him with our dilemma and were informed that the facts would be submitted to the general solicitor of the road. This was done and a day or two later advices reached us that

us that the train was running some eighteen or twenty miles per hour at the time it was decided that we be not put on the witness stand to testify in our own behalf, as under cross examination it might prove extremely difficult and embarrassing to reconcile the speed we were actually running with that called for in the ordinance. Following

this the conclusion was reached that others less familiar with speed than ourselves should be relied on to do the swearing and produce proof that the law had neither been violated nor ignored.

Reaching the inquisitorial chamber

some seventy years of age, with eyes still bright and a general appearance of being cold and unscrupulous. During the examination of this witness it was elucidated that he kept a grocery, with liquid attachment, on the street intervening between the bank wall paralleling

"Because I saw it go by my store."
 "Did you time the speed they were moving?"

"How was I going to time der speed when I was not on der train at all?"

"Did you have a watch at the time the train passed?"

"No, I was not. Do I need a watch to see dot train go by?"

"Did you have a clock with you?"

"How would I have a clock mit me? My clock is more than six feet high."

"How is it then, Mr. Schmidt, if you did not have any watch or clock by you that you could tell how fast that train was running?"

"Vell, twenty-six years ago my daughter lived in St. Louis und I went down there to visit mit her. When I come home der water was so low in der river dot steamboat could not get by those Keokuk rapids and I walked home from there. I walked up on der railroad track from Keokuk to Fort Madison in just four hours (24 miles) and dot morning when der train went by I walked down der sidewalk one block and while I was walking der train went more than two blocks, and I was walking just a little quicker than I did dot morning when I came up from Keokuk."

"Are you absolutely sure it was twenty-six years ago when you returned from that visit?"

"Yes, sir! I was just so sure as I could be."

"Now is it not possible that it was not more than twenty-four years ago?"

"It was not. I told you before, for I was there myself."



Akerljod, print, Kapagnolajck.

THE OLD METHOD FOR A MODERN RAILROAD NOT A SINGLE STEAM SHOVEL WAS USED ON THE TRANS-CIBIRIAN RAILROAD.

we found the justice of the court a congenial and, it might be added, convivial appearing gentleman who, when we were introduced to him as the defendants, did not seem to manifest any particular ill feeling but rather appeared sort of friendly like toward us.

The court room was well filled with that element of the community whose clothes did not denote affluent opulence though who appear to have ample time at their disposal to attend all public functions such as a circus, old settlers' reunion or police court and from which juries are usually compounded, though such luxury was not afforded on this occasion. The motley throng was called to order by the sheriff and proceedings formally opened. The chief witness for the prosecution was, of course, the Dutchman, supplemented by a number of business men of the town. These latter testified they had seen the train pass their places of business and to the best of their knowledge and belief it was running not faster than permitted by the ordinance. By the time their testimony had been given things began to look quite encouraging for our side while, on the contrary, the city attorney's profile assumed a sort of disappointed expression. "Call the next witness," sternly said the judge, and Jacob Schmidt mounted the rostrum and took the witness chair. Schmidt was a little, weazen, dried up appearing old man,

the track and his store and on the morning in question was sitting on the steps of his place of business and that the train passed at a rate of speed exceeding twelve miles an hour, this being substantially all that was brought out



Tomachkebleh, print, Kapagnolajck.

CONSTRUCTING THE RAILROAD.

before Jacob was turned over to the tender mercies of our attorneys for cross examination.

"Mr. Schmidt, how do you know that train was running more than six miles an hour?"

"Let us see," said the attorney, "twenty-four miles in four hours is six miles an hour; pretty lively walking on a railroad track, and on the morning this train is alleged to have exceeded the speed allowed you walked a little faster

than you did that day twenty-six years ago. Thus you walked at a rate of something over six miles an hour and as the train moved more than twice the distance you walked it was making more than twelve miles per hour?"

"Dot was just right, Mr. Van Valkenburg; dot was just right!"

"That's all," said the lawyer.

judge said I could have made that much if I had valked der five blocks from der depo' to my store, but der judge was wrong, for I came down on der train last week and valked up from der depo' and I didn't got one cent."

The noon hour having arrived court adjourned to 2 P. M., the sheriff again pleading a business engagement and we

peated, "this venerable townsman of ours, over whose head has passed three score years and ten"—"sixty-nine! sixty-nine," interrupted Mr. Schmidt—"has disgraced his adopted home by bringing nefarious charges against my clients, strangers to us, and causing them to be brought here before your honorable court. It has been shown beyond question that the charges are false, proof being abundant that this train did not exceed a speed limited by law. But this is not all, for we find that Jacob Schmidt has a grievance against the railroad and in his anxiety to obtain revenge for the paltry five dollars now reposing in the city treasury has perjured himself by swearing he walked six miles an hour, twenty-six years ago, on a railroad track, too, that the papers I hold in my hand prove has been built but twenty-two years. Jacob Schmidt's time honored veracity has been shattered by his ruthless perversion of the truth and I leave the interests of these men, whose reputation as law abiding citizens has been so despicably assailed, to the integrity of this honorable court."

Before the lawyer could resume his seat the justice jumped to his feet, violently striking the table with his fist as he arose, and shouted, "There is no case against these gentlemen and they are discharged."

The two alleged conspirators against the dignity of the law were wined and dined at the hotel that evening before departing for home; the lawyers would accept no remuneration for their services in our behalf; the city was mulcted for something more than a hundred dollars for court costs, while the trains

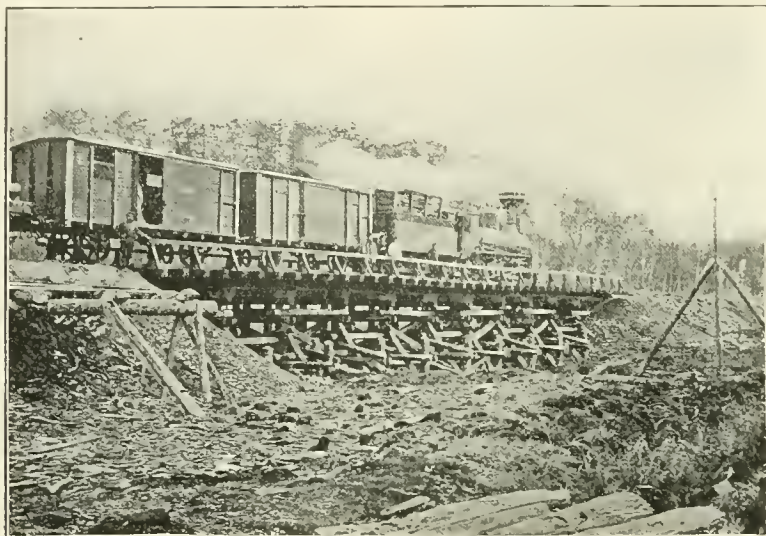

Gp-lee, print, Omek.

WOOD BRIDGE OVER THE STREAM COLDSLKY, (TEMPORARY BRIDGE BUILT BY PEASANTS).

Following this testimony six witnesses for the defence were called, among them three commercial drummers who happened to be on the train, two wholesale lumber merchants residing in town and the station agent. The drummers all gave the speed as from four to six miles per hour, while the others were introduced to prove that Mr. Schmidt had a grievance against the road and had repeatedly threatened to get even with it. He was again called to the witness stand and the colloquy between our attorney and he was resumed:

"Mr. Schmidt, is there not a city ordinance prohibiting any one alighting from a train of cars when in motion?"

"You vas wrong, Mr. Van Valkenburg; a man don't have any business to jump off when der cars is running."

"We will accept your interpretation," said the lawyer laconically, "and I would ask if you jumped off a train some three weeks ago when the cars were running?"

"Objected to," said the city attorney, "as irrelevant to the case on trial."

This precipitated the first clash between the opposing counsel and after a lively passage of pros and cons the justice directed the witness to answer.

"Vell, I stepped of and fell down and der sheriff came along and arrested me for violating the statutes; dot's what he said."

"Were you fined?"

"Vell, I paid five dollars and der

were left to go home with a friend of the conductor's for dinner.

At the opening of the afternoon session our attorneys made a motion that the case be not argued, but submitted to the justice for an immediate decision. To this the city attorney objected and with more force than eloquence endeavored to impress on the court the utter

disregard of railroad men for city ordinances, quite ignoring the particular case at issue, and his failure to produce proof that the defendants had laid themselves liable.

Then Mr. Van Valkenburg arose and, after addressing the court, took a sweeping glance over the, by this time, crowded court room. "Your honor," he re-

continued to make pretty fair time within the city limits and to this day, so far as the writer knows, no denizen of the town has ever noticed a train exceeding the speed prescribed.

A good book is the precious life-blood of a master spirit embalmed and treasured on purpose to a life beyond life.

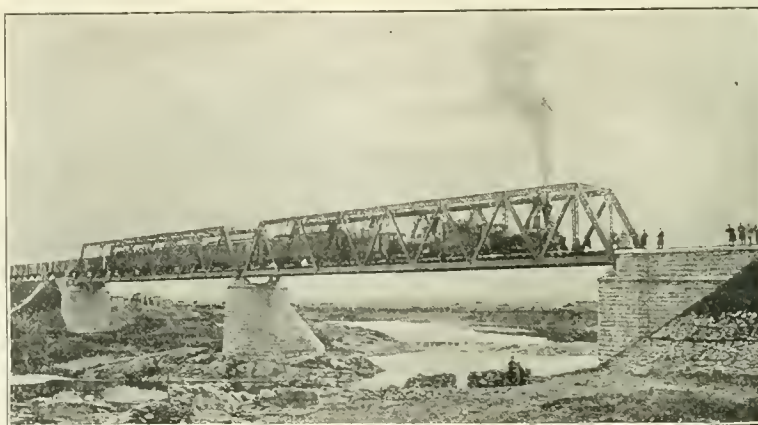

Hikolai Pen, print, Tomek.

RIVER IAIA, TYPE OF LIGHT TRUSS BRIDGE.

General Correspondence.

Early Engines in Michigan.

Seeing the illustration of the engine Stockbridge in a recent number of RAILWAY AND LOCOMOTIVE ENGINEERING recalls an engine of similar design, having a four wheel truck, one pair of drivers ahead of the fire box and a pair of trailers under the deck, that had a long and useful life in Michigan.

This engine was built by Rogers, Ketchum and Grosvenor, at Paterson, N. J., as the brass name plate on her driving wheels showed. It is said she was originally built for a road along the Mohawk river, now a part of the N. Y. C. R. R., and by this company sold to the Detroit & Milwaukee Railroad, some time previous to July, 1852. Her name at this time was Empire. In 1860 she was sold to the Port Huron & Lake Michigan Railroad, her name changed to Lapeer and later to Topsy. She was at first used for laying iron west from Port Huron till the road was opened to Emmett on November 18, 1860, when she was put in passenger service, as she was too light for the work train. In April, 1870, the writer began firing on her with Chas. F. Jones as engineer, and in 1871 and '72 had charge of her as engineer.

She had a four wheeled truck with 30 in. chilled wheels, one pair of outside connected drivers set just ahead of the fire box, with 56 in. cast iron centers and Lowmoor iron tires 2 ins. thick. These wheel centers were the same pattern as to the spokes, rim and crank pin boss as the Wm. Mason engines. She was very accurately counterbalanced, so she rode smoothly at all speeds. She was a "flyer" to run. I have ridden on her a mile a minute with one coach, many a time.

She had outside cylinders, about 8x14 ins.; neither cylinders nor steam chests had any lagging or jacket. It is said that these cylinders were never rebored, and I have been told by machinists who had worked on her that the valve seats were never faced. They were of such hard metal and of so fine a grain that they showed no signs of wear of any amount. The valves were of cast iron. As I remember, they had $5\frac{1}{4}$ in. outside lap and $\frac{1}{16}$ in. inside clearance. There were two eccentrics for each side securely keyed on the axle between the driving boxes and V hooks engaging with pins on the lower end of the rocker arm. The reverse lever had three positions in the quadrant, full stroke ahead, full stroke back, and mid-position with both hooks disconnected from the rocker arm. She had no starting bars to move the valves independently of the eccentrics as the

"drop hooks" had. Four bar guides and a crosshead pump with ball valves were used on each side. She had a Bury boiler with the "haystack dome," and a half round fire box. There were 96 copper flues about $1\frac{1}{2}$ ins. outside diameter, a very short smoke arch, with a flounced petticoat pipe and a balloon stack for wood burning.

The boiler was well made, of first class material. She has been known to carry 180 lbs. of steam when her standard working pressure allowed was only 100 lbs. The writer saw her with this high pressure taking 6 cars of railroad iron out of Port Huron yard up a 1 per cent. grade in November, 1870, with W. J. Rooney as engineer. When first built she had no steam gauge, only a spring

Engineer Chas. Webster was running her at this time. In 1879 she was scrapped and cut up by Master Mechanic George W. Prescott.

As she originally came to the D. & M. R. R. she had a small four wheeled tender. In 1860 the tender of the engine Syracuse was put with the Empire. This tender had a single pair of wheels under the front and a four wheeled truck under the rear end. It held about 900 gallons of water and $1\frac{3}{4}$ cords of wood. The exact weight of the Empire I never learned; she was said to weigh 9 tons.

While the D. & M. R. R. owned her, about 1854, Mr. McGregor spliced her fire box out 6 ins., which made her a good steamer.

The information about this engine



Electr. print, Openbpr.

ANOTHER TYPE OF BRIDGE, RIVER KOCYL.

balance attached to the safety valve lever; the gauge was put on in 1860. Her throttle was a slide of the gridiron type, close to the dome cover. Originally she had no cab, only a railing around the running board; when a cab was put on, it was put inside the railing, which was left on her. This running board extended only a little way ahead of the drivers, so it was necessary to crawl along the boiler and hand rail to get to the front end to oil the valves.

Under the deck was a pair of 33 in. trailing wheels, with a cross equalizer and big set screw to turn down and put more strain on the springs over the trailer boxes. In 1871 or '72 these trailers were taken out by Master Mechanic Robert C. Stewart to make her better for yard service. This stopped her slipping on bad track but left her so nearly balanced on her drivers that she was hard on her driving springs and her wheel centers worked loose on the axle.

while on the D. & M. R. R. comes from Engineer Henry C. Fuller, who began firing on her July 4, 1852. He was soon promoted engineer, and about 1855 ran the Empire steadily for some time. Engineer B. C. Walters also ran her. His name was stamped on her brass dome casing with the date July 4, 1854.

Mr. Fuller says that the first engine on the D. & M. R. R. was the Detroit, and next the Pontiac. Both these engines had four wheeled engine trucks and one pair of drivers. The Detroit had only one eccentric for each side: it could slip around part of a turn and reverse the engine. The Pontiac had a water tank under the boiler. Next came the Syracuse, a second hand engine, and later the Empire. At one time there were a number of photographs of the Empire, or Lapeer, as she was named then, around Port Huron, but I cannot get hold of one now, much as I would like one.

Possibly the Rogers Locomotive Works can give the details of the Empire as to her weight, dimensions, when she was built and what company first owned her. In her construction she had many ideas that are supposed to be quite modern but are shown in her to be over fifty years old.

CLINTON B. CONGER.

Chicago, Ill.

[We believe that this engine was of the Stockbridge type built by Rogers, Ketchum & Grosvenor for the Tonawanda Railroad in 1854. She was almost the last of that class built.—EDITOR.]

Inspirator Valve Gauge.

BY L. C. HITCHCOCK.

It has been some time since I contributed anything to good old RAILWAY AND LOCOMOTIVE ENGINEERING, but doubtless many of your readers can recall my series of articles on Running

We suspended the inspirator on the bench and dropped the lower end of the scale to the top edge of the forcer opening. Then placing the plain piece of steel on the scale we lowered it until its bottom end was even with the lower part of the valve seat. Then pinching scale and plain piece tightly together we removed them, and noted the distance between their lower ends.

This was a tedious and unsatisfactory mode of procedure, as it was a very difficult matter to see the position of the scale and plain piece when placed inside of the inspirator. Then, too, we had to cut and try the valve several times before it could be brought to its proper position.

To obviate this difficulty, Mr. J. F. Amidon, one of the brass finishers here, said he would like to have a gauge which would show the distance from the bottom of valve seat to top edge of the forcer opening, and one which he could

steam valve is screwed. The lower end of piece B, which represents the valve seat, should be cut at an angle slightly more acute than the angle of the valve seat proper. This insures the lowest points of the piece touching the lower point of the valve seat in the inspirator, as shown in an exaggerated manner by Fig. 2. The upper part of piece B should be notched out as shown, leaving it 1 1/8 ins. wide and 1 3/4 ins. long. The slot in each piece should be wide enough to allow a 1/4 in. machine screw to slide easily in it, and they should occupy about the relative positions shown. A 1/4 in. button headed brass rivet slides in the slot in piece A, and is riveted tightly in piece B. A 1/4 in. by 1/2 in. machine screw on which a brass thumb screw and washer work, is soldered securely in piece A and works freely in slot in piece B. To set the gauge, slack thumb screw and move piece B as far up on piece A as slots will allow, and again tighten thumb screw. Then place the inspirator on its delivery end, and taking the gauge by the thumb screw, pass piece A down through the opening for the wings of the forcer steam valve, and by a slight pressure downward on the thumb screw hold the lower end of the piece squarely and firmly on the top surface of the part in which the forcer opening is made. Now slack off the thumb screw and piece B will drop by gravity until its lower end strikes bottom part of valve seat as shown in Fig. 2. Tighten thumb screw and remove gauge, as it is properly set.

Now, as pieces A and B are of equal length, it naturally follows that the distance between the ends of them is equal at top and bottom, so that after the gauge is set as described, by holding it in the right hand and placing the top edge of piece B against the bottom edge of the seat of the valve when held in the lathe chuck, as shown by Fig. 3, the top edge of piece A will represent the top edge of forcer opening, and if the seat of the valve is faced off until the upper edge of piece A, thus held, extends 1/16 in. to the left of the right hand edge of the cylindrical part of the valve as shown at E, Fig. 3, when the valve is placed in its proper position in the inspirator the cylindrical part will surely extend 1/16 in. into the forcer opening as required. This it will plainly be seen, I think, that by the use of the gauge as described, a forcer steam valve can be made exactly the proper length before removing it from the lathe chuck and that too without taking any measurements.

South Tacoma, Wash.

Powdered graphite and signal oil make a good looking coating for smoke stack and front end. It gives a sort of what painters would call a metallic finish. It is cheap and will not scale.

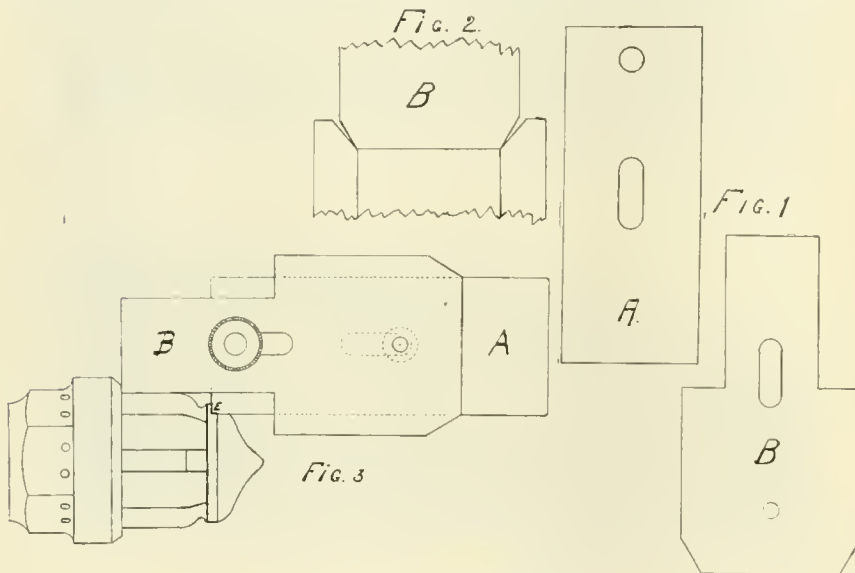

INSPIRATOR VALVE GAUGE.

Repairs which were published in your paper in 1892 or '93. To renew old acquaintance, in case you have published no similar article, I would like for the benefit of those whose duty it is to repair Hancock inspirators, type A, for locomotive boilers, to place before them, through the columns of RAILWAY AND LOCOMOTIVE ENGINEERING, the description and sketch of a gauge, made here in the South Tacoma shops of the Northern Pacific Railway Company.

The gauge is used for ascertaining the amount necessary to be turned from the seats of new forcer steam valves to be applied to inspirators after the valve seats in the inspirators have been reamed.

Prior to making the gauge, we ascertained by measurement, the amount necessary to be faced from the valve seats, using a 6-in. scale, and a plain piece of steel the width and length of the scale.

apply to the valve as it was held in the lathe chuck.

He and I then made one as per attached sketches, which works very satisfactorily, and to him I think is due the lion's share of the credit for the idea.

The gauge is made of Russia iron, the piece A, Fig. 1, is made wide enough to slide snugly in the opening through which the wings of the forcer steam valve pass, and for a No. 9 inspirator, which size the sketches represent, it should be about 4 ins. long. For inspirators of larger sizes this piece should be of sufficient length that when its lower end rests on the edge of the forcer opening, the thumb screw will come above the inspirator far enough to be easily handled. The pieces A and B, Fig. 1, should be exactly an equal length, but the width of the lower part of B should enable it to pass easily through the opening into which the bonnet for

Hose Splicing.

Will you kindly allow us space in your valuable columns in which to answer a recent inquiry from an inspector of air brakes and hose as to what we used in making the joint, or splice; if, as he presumed, it was a section of iron pipe, was there no trouble from leakage of air or the slipping of the hose. In reply we would say there certainly would be trouble from both causes mentioned by our correspondent. We do not make use of sections of pipe, but have a thimble cast from a pattern, with center collar and the necessary depressions, that when the bands are applied, as in new hose, the joint is air tight to as high a pressure as is ever required.

This inquiry led us to interview the inspector of hose on a railroad that has used our repair outfit for air, steam and signal hose for over four years. He informed us that he tested all spliced hose to 100 lbs. before putting them into commission, and of the 8,000 to 10,000 that had been spliced in his shop, there had been no trouble from any, and that they seemed to be about as good as new hose, which is accounted for from the fact that they made use of the good ends of old hose only. **BUKER & CARR MFG. Co.**

Rochester, N. Y.

How a Bolt Machine Seller Sold a Machine and Bolted.

BY A. O. BROOKSIDE.

A certain superintendent of motive power of a large railway system had been compelled to waste nearly a whole morning and to spend what the French call a "bad quarter of an hour," one day with an exceedingly pushful and time-consuming salesman—one Innis Rashfuss by name. This irresponsible being chattered and repeated and prosed and bellowed by turns, over the merits of the railway specialty he was trying to sell. The drummer had that peculiarly irritating faculty of telling his hearer, as brand new information, things which his hearer knew, and which he knew his hearer must know, and which his hearer couldn't help knowing that Rashfuss knew that he knew quite well all the time.

What this drummer said while he was tormenting his victim amounted, as Kingsley says, "to nothing at all and pure bosh and wind." He kept it up nevertheless, and used objectionable slang, and was too familiar, and he far overstepped the rules of ordinary business politeness. In fact, he trespassed grievously upon the greensward, till at last the "old man" rang for his chief clerk. Rashfuss was then carried off to the outer office, and the chief clerk, who would one day be somebody, spake not comfortable words unto him, but browbeat him as a savage man browbeateth his office boy when he finds

him alone. At length Rashfuss was made to emit sounds like weeping and gnashing of teeth as he realized that the one-tenmillionth part of the ghost of a fighting chance of getting a word of recommendation from the "old man" was now no more, gone, defunct, fallen down and utterly and irretrievably lost.

While all this was transpiring, as the daily papers say, a neatly dressed young man with a faultless Ascot tie, sat quietly in the office and heard it all and understood. You observe we did not use the slang expression, he "got next" but that would nevertheless have been strictly true. When this young man's turn came, he sent in his card and the superintendent of motive power read the somewhat reassuring name of Ernest Trendhome.

It seems that he of the faultless tie had a bolt machine to sell, and he had a sectional view of the same clearly depicted upon a neat little card, and he

Ernest Trendhome, with a courteous wave of the hand, backed silently toward the door. The S. M. P. leaped after him over the imaginary pile of bolts on the floor, and ordered his chief clerk to write, telegraph, and telephone at once for several of the Zurrock bolt machines from the Getthere & Trendhome Company, while the faint echo of the now far distant footsteps of the retreating salesman was the only sound which floated in from the outer world.

Moral: If you are rash and fussy and stray too often on the greensward you will one day be run over by the garden roller. If, on the other hand, you are possessed of the brevity of exceeding briefness, and can show how everything works, and above all how it sounds, and if you have the great moral courage to back silently and resolutely, though courteously, to the door when you are really done, then the world will look upon you as upon one who



AN OLD TIME AMERICAN BUILT ENGINE IN RUSSIA.

unobtrusively placed this upon the desk. The head of the motive power department reluctantly laid down the latest copy of RAILWAY AND LOCOMOTIVE ENGINEERING, and looked apprehensively at the stranger; the stranger smiled pleasantly and said, "Mr. S. M. P., you are busy. Our bolt machine is the topic. You use thousands of bolts?" "Millions," wearily responded the railroad man. "Ah," broke in the other, "enough said. I will not take your time. Observe this card. You put bar iron in one end of this machine, give it a whirl, and—" Here he made a gesture like a man engaged at bag punching, he also sidestepped quickly at the same time, and said explosively, "Zurrrr-ock-Bolts!!!"

The S. M. P. jumped to his feet to escape the deluge of bolts, so strenuous and so life like was the scene, while

can "make good," and you will be treated accordingly. If you keep mum your tongue will never be too fatigued to taste the extra dry, which will certainly come your way.

Railroad Cab Signal.

BY J. A. BAKER.

Among the exhibits at the B. of L. E. Convention there is one in particular deserving of mention, the Mills & Pidington Railroad Cab Signal System.

The device consists of relays, white, green and red incandescent lamps, bell alarm and recording instrument. It is operated by the closed circuit system. The local circuit controls the signal, register and light, and the relay the third rail.

The entire mechanism is carried in the cab out of the way of the engine's crew and so arranged as to protect it from dis-

arrangement. It does away with track batteries entirely and in no way interferes with the Block Signal System or cause short circuits. Should any of the battery wires break it affects only that particular engine. The battery, which is composed of 8 Sperry cells, furnishes only one volt, so that there is no danger of shock from contact. Of the 8 cells used one controls the rail and the other 7 the local battery. The white light indicates clear, green, caution, and red, danger. Should the current drop from any cause the signal goes to green, or should it increase, the signal goes to red. In both instances the electrical alarm bell gives continuous warning, and is an extra precaution should the lights fail or burn out. The recording instrument records the time and location of all defects, such as broken rails, misplaced switch, land slide, etc., on a clock faced dial. The third rail consists of a wooden sleeper 6 ins. square, whose upper face is protected by two angle bars $\frac{1}{2}$ in. thick and $2\frac{1}{2}$ ins. wide, securely ballasted to the sleeper and insulated. The track insulation is that used for all block systems and requires only the care of the track walker when he makes his trips over the line to know that all is well. The blocks may be arranged in lengths to suit speed, grades, etc. It is receiving a great deal of attention from delegates and visitors and receiving their endorsement, as it is one of the few devices that does not put an additional burden upon the engineer.

Shop Management, Organization and Methods.

"Loyalty is the foundation of success." That is what Mr. H. A. Lyddon, master mechanic on the Northern Pacific, believes concerning shop management and that is what he told the North-West Railway Club in an interesting paper which he read at a recent meeting. He pointed out that some of the advantages to be gained in shop organizations by having for the heads of the various departments, not only men of ability but men of character, loyalty and ability combined. In shops where loyalty prevails, Mr. Lyddon says, a feeling of freedom is to be found. The men in charge of the various shop departments work in harmony and in one another's interest, which is essential in maintaining good shop discipline.

Just here we feel constrained to remark that there are some railroad managers who seem to think that if they can only keep the officers and non-commissioned officers of railway departments fighting and spying upon one another, that when sufficiently harried they will let the truth leak out for the benefit of the company. No greater mistake was ever made. What such

management tends to develop is "team-play" among those who are habitually pitted against each other, and not always perfectly honest team play at that.

In support of the theory that men of good character as foremen can exert a powerful influence in favor of right conduct and right living, Mr. Lyddon told of a workman who had taken and acted on a piece of wholesome advice given in a friendly way by his superior officer. The man in talking to the official about six months later referred to the good advice and remarked that it had resulted in a "white swelling," and also that the man was turning out more work than formerly, his family were better looked after, and his own leisure was used for home study. As the meaning of the white swelling was not apparent the man explained that it was a pocket book swelling caused by accumulated silver coins and that he had \$75 which he was about to deposit in the

handle any work required of a first class mechanic.

The average mechanic of to-day is anxious to improve his general knowledge and ability. The most successful foreman is the man who makes an effort to help those who are desirous of helping themselves, and the same applies to men who hold more important positions. J. A. Y.

A Three and a Half Ton Foundry Ladle.

The enclosed sketch is of a three and one-half ton ladle, which can be made very cheaply with such material as is generally found around a railroad shop. The ladle is 37 ins. diameter inside, and is made of $\frac{3}{8}$ in. tank steel, with a dished head in the bottom. It has a ring $3\frac{1}{2}$ ins. wide by 1 in. thick at center, gradually thickened up at the sides to $1\frac{1}{2}$ ins. riveted to it. The arms are welded to this ring, which forms a shaft for the upright

bars and also serves as guides to steady ladle. A removable hand wheel is attached to a worm, which is fastened by a bracket to one of the uprights and meshes with a gear on the shaft. This ladle has each side belled to form a spout for pouring and has a lining of fire clay $1\frac{1}{2}$ ins. thick; it can be adjusted to a nicety and the extra amount of weight on one side caused by the hand wheel, worm and gear, does not amount to enough to throw it out of balance.

This ladle has been in operation for over ten years and outside of renewing lining, has not cost one cent for repairs. G. E. LEE.

Kingston, Ont., Canada.

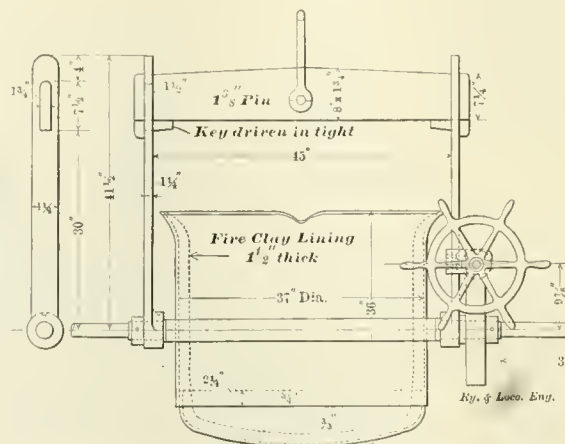

EASILY MADE FOUNDRY SHOP LADLE.

bank. The speaker added that the man had steadily prospered and was now in charge of a boilershop of his own and probably had a yellow swelling in his pocketbook by this time.

Mr. Lyddon thought that the general knowledge and ability of the average railroad mechanic is below what it was 18 or 20 years ago. In his opinion the cause for this lies largely with the official directly in charge. How often, he says, have we known of an apprentice being compelled to run one machine for a year or more, simply because he had thoroughly familiarized himself with its operation and could do more work than a new hand could do. This is not good for the man nor for the company, because it does not tend to turn out "first class all round" mechanics. In some cases, such as in our largest railroad shops, making specialists of men has nevertheless resulted advantageously, but, the speaker held, that in no instance should a specialist be made except he be a man having had at least four years' experience, and qualified to

What Are the Lugs for on the M. C. B. Car Brass?

It is quite possible to cut the lugs off an ordinary car brass, and yet use the brass very satisfactorily after the cutting off has been done. Some men cut off the lugs are to take up end thrust, some one knocking them off without ceremony, and then the brass is put back on the journal, and it works apparently as well without the lugs as it did with them. Some car repairers believe that to knock the lugs off a brass used on a journal which is inclined to heat will prevent it heating. Whether it will do this or not is beside the question just now.

If the brass is, to all intents and purposes, as good without the lugs as it is with them, it may well be asked what is the use of having any lugs at all? The lugs are to take up end thrust, some one

says. Well, so it is; but end thrust appears to be as well taken care of when the lugs have been knocked off the brass as when they are on; therefore, what is the good of the lugs? This looks something like the famous old question and answer: "What is the good of anything?" "Nothing!"

When a car brass is in place on the top of a journal with the wedge on top of it we find first that the brass is somewhat shorter than the journal; second, that there is a space between the inner and flanged end of the brass and the inside end of the wedge when the brass is in, and the wedge out as far as they will go; in other words, there is always a certain amount of intentional lost motion or "play" between brass, wedge and journal.

If the journal attempts to come out through the axle box cover, it can move only about one-quarter of an inch in that direction when it is stopped by the shoulder on the journal, next the wheel seat, coming up against the inner or flanged end of the brass, and the flange of the brass coming up against the back end of the wedge, and the front of the wedge coming up against two small projections which hang down from the roof of the axle box. If, on the other hand, the journal tries to disappear through the dust guard, it can move about $\frac{1}{4}$ of an inch toward the back of the box when it is stopped by the collar on the outside of the journal encountering the outer end of the brass, and pushing the brass back so that the lugs on its sides come each against the two upright ribs cast on the two sides of the box.

This arrangement "takes care" of end thrust in both directions; yet the lugs can be cut off, and the ability of the brass and box to deal with end thrust, destroyed where the journal goes away from the cover. The journal, however, does not go out of the box through the dust guard end. In each box motion of the journal toward the box cover is resisted by brass wedge and box, and motion toward the dust guard is resisted by brass and box only. The question here arises what is the further function of the wedge, and like Rudyard Kipling, we answer, "that is another story."

At the time that the journal is trying to get out through the dust guard in one box, its fellow journal at the other end of the axle is trying to get out through the cover of the other box, and we have brass lugs and box ribs resisting this motion at one side and brass flange, wedge and box roof projections resisting it at the other. It is easy to see that this arrangement is an example of design where each box, brass and wedge is a unit capable of resisting thrust in both directions. The wear on the ends of the brass and the collar and shoulder are thus equally divided.

If the lugs on one brass be cut off the end-ware on the outside of that brass is done away with and double the wear is put upon the shoulder and inner end of the brass in the other box. This is why it is possible to cut off the lugs and yet apparently have the brass run all right. If you cut off the lugs of both brasses on one axle you are coming in sight of the collarless journal idea. The design of each box is complete in itself because any box and its contents taken together are capable of properly resisting end thrust in both directions.

Steel Tire Flange Gauge.

Some of the cheapest and simplest devices in a shop frequently prove to be exceptionally valuable. I present herewith a tire flange gauge which was originally made in our shops and which I have never known to be in use

elsewhere. This gauge has a three-fold value—first, it gives the proper height to flange; second, it gives the correct distance from back of tire to the throat of flange and an exact outline of flange on the tread side of the wheel, and third, by the use of this gauge one may readily tell before placing the wheel in the lathe just how much stock must be removed from tread of wheel to produce a full flange, and it is the last feature that I desire to call attention to. When more stock is removed than is necessary to make a full flange, it is valuable material wasted, and such a proceeding is sure to provoke serious comment on the part of the master mechanic. When one-eighth of an inch more than necessary is removed from a set of wheels, it means from three to four months' good wear lost. Some railroads prac-

tice leaving a small witness mark on the thinnest flange as evidence to show that only the necessary reduction in diameter had been made. This is an excellent practice and removes all doubt. When preparing to turn a set of tires the first step is to find the smallest wheel, and also to find the wheel with the sharpest flange, as between these two we are to ascertain the proper diameter for the entire set. Reducing the diameter of the smallest wheel until the flange is full, may not rectify the wheel with a sharp flange. In this case our finished diameter must be taken from the wheel with the sharp flange, and by use of the gauge shown we may accurately determine the amount to be removed and so avoid the common practice of guessing at it. Gauge A is held in one hand over tire

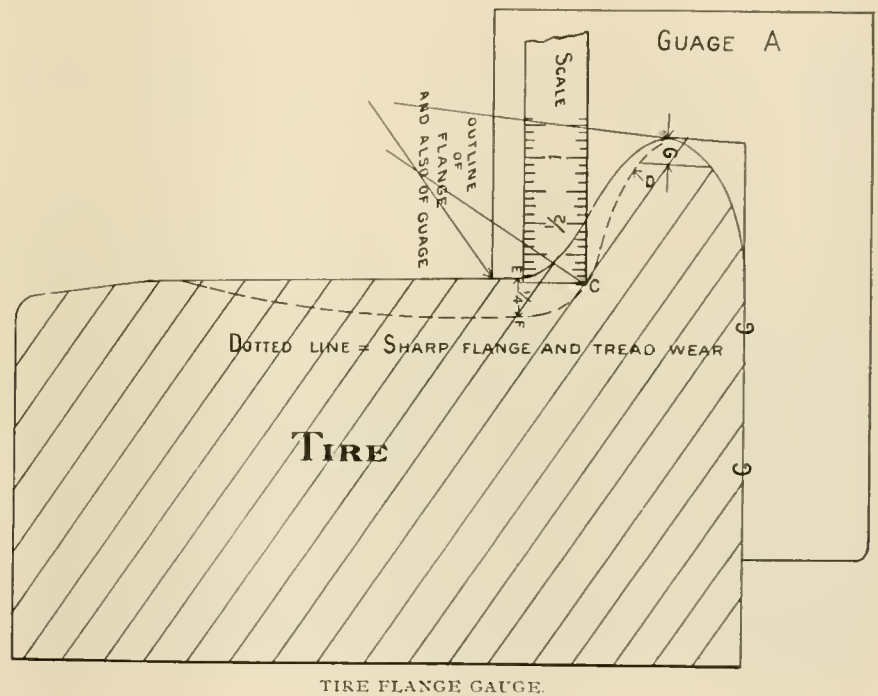

elsewhere. This gauge has a three-fold value—first, it gives the proper height to flange; second, it gives the correct distance from back of tire to the throat of flange and an exact outline of flange on the tread side of the wheel, and third, by the use of this gauge one may readily tell before placing the wheel in the lathe just how much stock must be removed from tread of wheel to produce a full flange, and it is the last feature that I desire to call attention to. When more stock is removed than is necessary to make a full flange, it is valuable material wasted, and such a proceeding is sure to provoke serious comment on the part of the master mechanic. When one-eighth of an inch more than necessary is removed from a set of wheels, it means from three to four months' good wear lost. Some railroads prac-

as shown. In the other hand a scale is held keeping it as nearly parallel to line B, as the eye will permit. Place corner of scale C in contact with sharp flange at D. Now move the scale downward, keeping C in contact with flange and note carefully where scale intersects outline of gauge. Move the scale up and down until you find the greatest distance between C and outline of gauge. To illustrate, if the distance is one-half inch as shown, then it is quite evident that the gauge where scale intersects it cannot come in contact with flange until gauge moves one-half inch on a radial line. You will note that gauge at E is one-quarter of an inch from tread of wheel at F, and these two points, E and F, may be brought together by turning one-quarter of an inch from top of flange G, which will shorten the or-

iginal distance of one-half inch down to one-quarter inch, the latter being the exact amount required to give a full flange. If a witness mark is desired subtract one-eighth inch, and your cut will then be one-eighth inch deep on the tread of the wheel.

J. B. PHILLIPS,

Foreman A. T. & S. F. Shops.
San Bernardino, Cal.

The "Saxon;" Grade Crossings.

As you ask for information regarding the old "Saxon," built by the Mason Machine Works, I think I can supply something thereof which may please some of your readers, who, like myself, have not forgotten everything in growing old, and who are not of the opinion that all the mechanical excellence in the world began at 12.01 A. M., January 1, 1900.

The "Saxon" was one of a large number of engines built for the L. S. & M. S. in 1871, of which number the Mason Machine Works furnished, I think, twenty.

The boilers of the engines were built of Singer, Nimick & Co. steel, warranted to show a tensile strength of 80,000 lbs. P. S. I., and the tenders of B. B. iron, manufactured in Wolverhampton, England, my house, supplying the material to Mason, as well as to Manchester and the Rhode Island Locomotive Works.

So much for the Saxon.

I note with great pleasure your remarks upon grade crossings, especially those in the less settled portions of the country, and am very much pleased with your suggestion as to the erection of large gongs for warnings for these remote and solitary mantraps, and I am very much more pleased with my own suggestion, which I turn over to you without money and without price, it being simply the thought that the proper warning for a gateless crossing everywhere is the steam whistle, properly constructed and properly sounded.

I say, properly constructed. The tall bells, 10 or 12 ins. high, are useless. They reverbrate among the mountains and sound like Cathleen Mavourneen's "Horn of the hunter that is heard on the hill," where there are no grade crossings or travelers to risk their perils.

The child's toy, known as the chime whistle, may be very agreeable to the ears of those in the parlor cars, who are perfectly safe at all grade crossings, and who can play a requiem on the jewsharp while the unfortunate passerby is being ground to pieces, but as a signal, either of danger or of anything else it is quite ridiculous.

I say, properly sounded. The unlucky plan adopted by the P. R. R., and followed by almost all the roads

in the country, of two long, melancholy tutes, followed by two shorter snorts, at a distance of some 60 or 100 rods, from the crossing, is as valuable for the purpose of warning as a dinner bell would be for a fire alarm.

The sound begins too soon, it ends too soon, and carries with it no special import.

Certainly if within the city streets the driver of a team should wish to admonish the foot passengers crossing its path, of danger, he would hardly take off his hat and sing the first bar of "Old Hundred" into it, that he might caution the passing wayfarer, and yet such warning would be better than that given on most railroads.

But, after all, what of it? The engine doesn't feel it, the engineer can't help it, the burial is soon over, the general manager eats his breakfast next morning, consoling himself with the reflection, if he needs consolation, that we must all die sooner or later.

GEORGE H. LLOYD.

Boston, Mass.

Knowledge and Skill.

We frequently receive requests for books that will teach men how to perform machine shop work, such as the reducing of rod brasses and the facing of valves. No book can teach that work any more than books can teach a person how to play the fiddle or to make cannon shots with billiard balls. "Chordal," in one of his famous letters, says: "In handiwork there are two elements—skill and knowledge of skill. Thus, in hand turning, the knowledge of skill tells us that a certain kind of chattering proceeds from a certain peculiar handling of the tool. Skill shifts the tool around properly and the chattering stops. Probably the exercise of skill in holding the tool properly cannot be described, and if it could, he who was the most skilful would probably be the most or the least adapted to describe it. You see a man filing something rounding: you take his file and file it flat. He asks you how you did it; you answer that you do it but do not know how you do it. I do not believe that any man knows how he files flat. There are lots of things the skilful do which have no 'how' or 'wherefore' to them that can be got out of them.

"The witness on the stand said, 'I know it to be so;' and the attorney, on cross-examination, said, 'On your oath, how do you know it to be so?' and the witness said, 'On my oath, I do not know how I know it to be so.'

"A man may know lots of things without knowing anything about how he knows them. There are many elements of manual skill, only a portion of which may be stated in descriptive terms.

"When a man wants to learn draught-

ing, the first thing he begins to inquire about is some book out of which to learn draughting. When some other man wants to learn draughting, he goes at it and draughts, and the going at it and the keeping at it constitutes the learning. All the books under heaven will not stuff a man so full of knowledge that he can say that he is a draughtsman before he has commenced to draw. If it was a question of books, all he would need to do would be to acquire all the knowledge that is in them. I am a sort of a draughtsman myself, and I give it as my honest opinion that books on draughting should be read only by draughtsmen, and not by people who wish to become draughtsmen. These books should be entitled, not 'Information for People Desiring to Learn to Draw,' but 'Information for Draughtsmen.'

"In my opinion, the art of draughting is one of those things which, so far as the art itself is concerned—that is the skill of it and the practice of it—will force itself upon a person. He will draw in spite of himself; if there is any earthly necessity for his drawing, if the necessity and the honest desire arise, he will draw, and draw, and draw. He becomes a draughtsman—may be a good one, may be a poor one—and the books will do him good in either case. He needs them to initiate himself as a draughtsman, but I hardly think that he needs them to initiate himself as a draughtsman. I draw a broad distinction between the geometry of the art and the art itself—between the perfectly-drawn line and a comprehension of what the line means. He who is up in the science of lines and figures and bodies is a scientific draughtsman, but he is no more a draughtsman than he who knows nothing of them. The skill to delineate the creeping spider or the ugly lathe leg has nothing whatever to do with the laws of natural history, or the laws of the strength of material. A draughtsman may be more useful from a knowledge of the strength of material, precisely the same as he may be more useful by reason of being versed in natural history.' When I speak of the art of draughting, I mean the art, pure and simple, of delineation, not of design or of mechanical analysis, or of comprehension of the thing delineated."

Tricks in Car Building.

The fierce competition for orders frequently brings work to contract shops which leaves no margin of profit, the result being that dishonest concerns try to even up by inferior work and material. A correspondent of the *Railroad Gazette*, who appears to know whereof he speaks, tells an inside story of practices that have a demoralizing effect upon the life of cars. Here are a few extracts:

"The favorite method of covering defects of wood and iron in this business is putty and paint for wood and soap and plumbago for iron; but since the advent of two or more inspectors on a contract this has to be done very cautiously. Men used to get so expert in plugging castings that when the good and the bad were mixed together they themselves could not tell which was which. Iron axles were especially watched by the inspectors. The roughing cut across the journal would sometimes show a crack or cold shut, but a vigorous peening of the crack before the smoothing cut was taken would generally make it finish smooth and nice. If the crack was too big, then a little lead or babbitt metal or a bright shaving from the axle was used to good advantage. This saved time and the cost of a new axle and the inspector, unknowing, congratulated himself on what a good job was being done when he ran his hand over the smooth, bright journal.

"A smooth way to get a condemned sill through was once worked on an inspector, and he never suspected the trick. He had ordered a bad sill taken out of a car, and the superintendent promised to do it at once. That night the change was made, but instead of the body builders doing the job, the paint gang got the car ready. They selected a car ahead of the condemned one standing on the same track in the paint yard and erased the numbers on both cars, renumbering them in reverse order. Then they switched them around on the track, the bad one ahead and the good car behind. The inspector was delighted the next morning and said he had never seen a neater job of sill changing done."

"One of the neatest jobs I ever saw carried out was on a lot of cars where was specified that the oil-box bolts should be double nutted. The bolts were got out for a single nut and were two threads too short for even that. The inspector raised a row after about twenty-five or thirty cars were up, so the foreman promised to have them changed the next day. Next day was Sunday and the inspector had gone home the night before, so they proceeded to cut threaded pieces long enough for the purpose and turn them into the threads of the nuts on the short bolts. A second nut was run on the extension piece and turned up tight against the bottom nut, making to all appearances a double nutted bolt. The inspector never knew the difference, and the company saved the cost of new bolts and taking the trucks out from under the cars to put them in."

"Sometimes in finishing a job a good many malleable castings get mislaid, lost and broken. We always began invoic-

ing these castings a month before the end of the job, and if any were missing the superintendent would have a pattern made and enough gray iron castings made from it to make up the difference. These were put in the heating furnace, covered over with burnt molding sand and the night watchman told to keep a fire going on them all night. We would do this on Saturday and let them cool off slowly over Sunday. Monday morning, when they were taken out, the castings would be very soft and would pass for malleable nine times out of ten. Leaving out bolts that won't be noticed, from two to eight a car, cuts quite a figure on a 500 car contract. The nuts are generally scant in thickness from 1-16 to 3-32 in., and this is another item of saving."

"The company got the worst of it on

the two cars finished while he was gone, and saw that sound stuff was put on instead."

Carborundum at St. Louis.

The Carborundum Company, of Niagara Falls, N. Y., have shipped two freight cars loaded with their products displayed at the St. Louis Exposition. The exhibit occupies Block No. 16 in the Machinery Building, and is one of the most elaborate ever made by the Carborundum Company. One of the principal features is a great pyramid of carborundum crystals, seven feet high and six feet in diameter at the base. The crystals are of the most beautiful shapes and colors, and produce a really dazzling effect when properly lighted. The balance of the exhibit will be made up of carborundum wheels, sharpening stones and other products; also samples of dif-



BIG HORSE TRIED TO STOP THE TRAIN. NEW ZEALAND RAILWAY WRECK.

ferent work that has been made possible by the use of carborundum. It will be one of the notable exhibits in the Machinery Building. The display is in charge of Mr. William H. Arison, who had charge of the carborundum exhibit at Buffalo, and Mr. E. W. Gaylor, who was in charge of the Charleston, S. C., display.

Aunt Sally (from the West)—Waldo, would you like to take a ride on the choo-choo cars with me?

Waldo Brownbeans (of Boston)—Why, certainly, my dear aunt, if there be such a method of locomotion. Doubtless it would be extremely interesting. I had hitherto presumed that the old methods of steam conveyance were still in vogue.—*Chicago News.*

one deal when it got up against an inspector from a western road who had a large capacity for tarantula juice. The superintendent wanted to work off some old siding that had been condemned, and, knowing the inspector's failing, took him uptown one afternoon to pass away a few hours while the boys could use up the siding. The treasurer and the president of the company were asked to come along too. The red eye was passed around and around, until the company began to wobble and have difficulty in making themselves understood. Our friend from the West seemed to get better all the time and talk more volubly, until the three schemers were knocked off their pins and had to be taken home in a hack. Then the inspector went back to the shop, made them tear the siding off

ferent work that has been made possible by the use of carborundum. It will be one of the notable exhibits in the Machinery Building. The display is in charge of Mr. William H. Arison, who had charge of the carborundum exhibit at Buffalo, and Mr. E. W. Gaylor, who was in charge of the Charleston, S. C., display.

Aunt Sally (from the West)—Waldo, would you like to take a ride on the choo-choo cars with me?

Waldo Brownbeans (of Boston)—Why, certainly, my dear aunt, if there be such a method of locomotion. Doubtless it would be extremely interesting. I had hitherto presumed that the old methods of steam conveyance were still in vogue.—*Chicago News.*

Railway and Locomotive Engineering

A Practical Journal of Railway Motive Power and Rolling Stock.

Published Monthly by

ANGUS SINCLAIR CO.,

174 Broadway, New York.

Telephone, 984 Cortlandt.

Cable Address, "Loceng," N. Y.
Glasgow, "Locauto."

Business Department:

ANGUS SINCLAIR, President.
FRED M. NELLIS, Vice-President.
JAMES R. PATERSON, Sec'y and Treas.

Editorial Department:

ANGUS SINCLAIR, Editor.
F. M. NELLIS,
GEO. S. HODGINS, } Associate Editors.
JOS. A. BAKER, }

Advertising Department:

Eastern Representative, S. I. CARPENTER, 170 Summer St., Boston, Mass.

British Representative:

THE LOCOMOTIVE PUBLISHING CO., Ltd., Amen Corner, Paternoster Row, E. C., London.

Glasgow Representative:

A. F. SINCLAIR, 15 Manor Road, Bellahouston, Glasgow.

SUBSCRIPTION PRICE.

\$2.00 per year, \$1.00 for six months, postage paid to the United States, Canada and Mexico. For other parts of the world, \$2.50 or ten shillings. Single copies, 20 cents. Remit by Express Money Order, Draft, Post Office Order or Registered Letter. Mailing address can be changed as often as necessary—always give old and new address, and if you subscribed in a club, state who got it up. Please give prompt notice when your paper fails to reach you properly.

Entered at Post Office, New York, as Second-class mail matter.

Copyright by Angus Sinclair Co., 1904.

For Sale by Newsdealers Everywhere.

Watching Scientific Progress.

The times are still within the memory of men still living, when a sentiment against receiving information about railroad mechanical matters from books or published writings was so strong that men of studious habits, who wished to learn more about the machinery they repaired or handled than what could be drawn from exterior inspection, used to keep the books and papers which they consulted, hidden out of sight in the way that other men concealed certain bottles. Men who are now near the retiring age, who have been helped towards success by the study of books, remember with amusement the embarrassing experiences they went through with a class of men who were in prominent evidence in the "good old times," the men who were loud mouthed in their assertion that all they knew about engines and machines was learned by "hard knocks." No book learning in their knowledge of their business! Their loud vaunted boasts of what they knew were used as thin screens to blind others about the dense ignorance of the ultra practical engineer or mechanic. The empty pretense imposed upon youngsters and a few foolish imitators, but the reading studious man reached the front rank

eventually even, although he was a little ashamed of the forces which contributed to his success. The new comer of to-day has no cause for apologizing about learning things from books. He finds congenial associates everywhere.

The books which fossilized ignorance despised contain in condensed form records of the experience and discoveries made by the master minds of past centuries. Many of the inventors, investigators and discoverers whose work has been of inestimable value to engineering are known to modern readers and workers as mere abstractions. A few facts about their benefactors may interest our readers.

About the first mechanician we have to credit with inventing useful apparatus was Ctesibus, a Greek, who flourished about 230 B.C. He invented a pump and clepsydra or water clock, and was a teacher of philosophy. His most famous pupil was Hero of Alexandria, whose acquaintance with pneumatics and hydraulics was beyond anything previously known. He is credited with being the inventor of the aeolipile, the most ancient steam engine known. He wrote a book on pneumatics which gives the earliest reliable information about mechanism employed in the world of his day. Hero's time appears to have been a period of progress for it was the fashion among learned men to improve mechanical appliances and to invent new ones. Ever since civilization made any progress, there have been skilful artisans whose handicraft developed constructive art, but their work was confined to their own circle. The inheritance to posterity of the usefulness of the mechanical manipulations is due to the writers who perpetuated operations that otherwise would have been lost.

There was a long period of dreary sterility of invention between the time of the Greek philosophers and the modern apostles of engineering science. A ray of progressive light first flashes up in the sixteenth century in the person of Galileo, the Italian philosopher, mathematician, astronomer, inventor and mechanician. Strangely enough Galileo is best known as the expounder and defender of the Copernican system which teaches that the earth is a sphere instead of a vast plane as formerly believed. The philosopher was persecuted for what was considered heresy on account of his advocacy of the Copernican theory, a hardship which may have served to emblazon his name to posterity. If he had never paid any attention to astronomy, the world would have been a small loser, but other work which he performed and received comparatively small credit for, greatly enhanced the comfort and happiness of mankind. Galileo noticing in church

one day, that the oscillations of a hanging lamp were equal in duration, he conceived the idea of a pendulum and that led to his inventing the clock. He also invented the thermometer, the microscope, the telescope, and made important discoveries about the velocity of falling bodies, and formulated the principle of virtual velocities.

Questions relative to heat, steam, electricity, hydraulic, pneumatic, and all other lines connected with engineering science, have been exhaustively investigated *con amore* by many men of commanding ability and monumental industry. Their discoveries are all open to the men who undertake to study books. Printers' ink has made the profoundest philosophies and the most valuable discoveries free to every inquirer.

Discoveries relating to phenomena of heat and steam are of particular interest to our readers. While investigating the action of steam driving a piston it is sometimes necessary to assume, for instance, that steam can be admitted without loss of heat or diminution of pressure into a cylinder made of conductive materials, or to exhaust it without back pressure; but to render clear certain calculations respecting the manipulation of steam, it is convenient to assume that other impracticable operations are possible. Many valuable and interesting laws, facts and figures relating to the behavior and action of steam, which the engineering world accepts as being absolutely correct, could not be demonstrated with any degree of accuracy in the ordinary practical working of the steam engine. They are the discoveries and calculations of accomplished physicists and mathematicians, who have devoted laborious and skilful special investigation to the subject aided by ingeniously designed apparatus. In studying out questions relating to heat and steam, the engineer often has to accept, as implicitly as he believes the multiplication table, formulas and tables of data given in handbooks which he has no means of verifying. Facts, figures and tables about heat and steam that excite but little attention from the men daily using them, are in themselves monuments of assiduous and accurate scientific labor, built up by eminent men who have devoted life long efforts to the investigating of nature's laws. Among the physicists and mathematicians whose names are identified with the investigations bearing directly in steam engineering, are many whose existence is merely an abstraction to the ordinary engineer, yet their labors have materially lightened his work, and supplied him with data for calculations that enable him to measure heat as ac-

curately as the farmer measures his corn.

More than two centuries ago, Robert Boyle, Earl of Cork, an Irish nobleman and chemist, discovered the law that the pressure of a gas varies inversely as its volume, and directly as its intensity, and which is yet often spoken of as Boyle's law. About the same time Mariotte, a French physicist, was investigating the same subject, and his discoveries were similar to those of Boyle, but somewhat fuller, so that the law referred to relating to gases is often called the Mariotte law. About a century ago Benjamin Thompson, Count Rumford, an American engineer, discovered and proved the immateriality of heat, and showed that heat and mechanical work are mutually convertible.

Before Rumford's time people believed that heat was some sort of elusive substance which they called caloric. While watching the boring of cannon and noticing the heat in the metal shavings he was moved to investigate its cause, since the old theory of heat did not provide for the shavings being warmer than the rest of the cannon. He proceeded to investigate and discovered that the mechanical energy used up in cutting the iron was converted into heat. Rumford's work prepared the way for the labors of Joule, an English scientist, whose ingenious experiments and investigations resulted in the determining of the mechanical equivalent of heat, to the satisfaction of the scientific world, although the determination of Joule was not so near the truth as Rumford's figures which were 778, within a small fraction of what instruments of wonderful precision show to be the correct mechanical equivalent.

Joule's experiments made out 772 foot pounds as being the mechanical equivalent of raising the temperature of one pound of water one degree at its greatest density, but later investigations have proved the correct equivalent to be 778.3 foot pounds.

Early in this century, Dalton, the famous English chemist, and Gay-Lussac, a noted French chemist, made some very important discoveries as regards the effects of temperature on steam. A few years later Messrs. Fairbairn and Tate, celebrated British engineers and physicists, by calculation and experiment established the relative volumes and pressures of steam through a range of temperature suitable for the steam engineering practice of that time. The same department of research was afterwards taken up by Regnault, the famous French scientist, already referred to, and he conducted at the expense of the French government and under the auspices of the French Academy of Sciences a most

exhaustive series of experiments with heat, water and steam. They were wonderfully accurate, and extended through a wide range of temperatures and pressures. That was fifty years ago, and the results they ascertained still remain standard, and are regarded as models of precise physical work. The experimental inductions of Regnault relating to the densities of, or volumes occupied by, steam under different pressures, were to a great extent demonstrated mathematically to be correct by Professor Rankine, the celebrated Scotch mathematician and engineer, who also formulated numerous equations of thermodynamics. Of late years Daniel Kinnear Clark, the celebrated investigator of locomotive problems, and Chief Engineer Isherwood, of the American Navy, have made many valuable discoveries respecting the action of steam in the practical operations of the steam engine, and their demonstrations of the cause and extent of cylinder condensation entitle them to eminent positions as physicists.

Scientific investigations are by no means ended. Many people for pure love of knowledge and others for its high rewards are still laboring after truth in many fields; and their discoveries are likely to be as great in the future as those of the savants whose work is done, and whose successful labors have become the heritage of the world. The people who are keeping in line with current discovery by reading journals and books are those who will first reap the benefits of their application. The saying that "knowledge is power" is as true to-day as it ever was.

Roundhouse Foreman of 1904.

As a sample of advice to a superintendent of motive power, the following will touch a chord in the heart of any man who knows what a roundhouse foreman really is, and what he has to do. The semi-humorous advice is from Mr. N. O. Thompson, and is contained in a series of "Don'ts" at the end of his paper on "The Round House Foreman of 1904," recently read before the New York Railroad Club. He says, "Don't carry the idea to your foremen that they are the whole thing when things go wrong, and ignore their existence when things are running smoothly."

We speak of this as being a semi-humorous piece of advice and so it is in the very apt way it is put, but the underlying idea is fact, and it is that when things are running smoothly, that is in general the result of the foreman's regular work and is the normal state of affairs, but when things go wrong there has been a temporary dislocation somewhere and the foreman is probably the

man by whose ability and good judgment the tangle will be straightened out.

Mr. Thompson, in his paper, pays a just tribute by implication to the technical press as the vehicle through which eminent writers have reached their audience and to the good work which railway clubs and railway societies have done to facilitate the movement of power from the time it arrives on the track where enginemen deliver up their engines until the engine is reported as ready for service again. Brainy railroad men have worked on the problem of designing and perfecting easy methods of working so that unnecessary movements or a possible blockade of power from yard to roundhouse and from roundhouse to yard may be avoided.

This, he says, has been done, and facilities for inspection and repair work have been provided without any penurious counting the cost. Yet, he tells us, a vice president and general manager of an important road told him that the advent of modern improvements had not hastened the movement of engines through the mechanical department terminals enough to give an adequate return for the money spent. In fact the general manager, who had once been a roundhouse foreman expressed himself as being bitterly disappointed at the result.

The writer of the paper pertinently asks at this juncture, Was the man behind the gun, or, in other words, the roundhouse foreman, been given the same consideration and the same careful thought which has been bestowed on the providing of facilities for doing work? He answered his own question by saying that this most important spoke in wheel of the mechanical department has been almost lost sight of, in the rush to look after all the other dividend producing spokes and even cogs of the wheel.

Great care has been taken in selecting foremen for every other department of the railroad shop but, of course, any one can be a roundhouse foreman. The fact that "anybody" does not make a good roundhouse foreman has been proved over and over again in times of stress and strain by the fact that the master mechanic or some such officer can improve roundhouse efficiency by "taking hold" at a critical time and staying with it. Mr. Thompson knows whereof he speaks when he says, it soon becomes unsatisfactory after the departure of this official when an extraordinary movement is wanted, particularly on Sundays, when some of the passenger power could be temporarily used for freight service. Some higher officer is apparently wanted for Sundays. This, he says, is believed to be wrong. It is wrong, but it is not the roundhouse foreman's fault. The roundhouse foreman of to-day should be on a level in authority with the master mechanic, at

least. He should be a man of clear judgment, he should know how to handle men, as he comes in contact with an intelligent class of men who are very jealous of their so-called rights. To avoid serious friction, and to obtain the best results he must be endowed with as much, or more, diplomacy as our foreign ministers. We think there is one thing Mr. Thompson might have added; to do this, the company must respect his authority as well as the men under him.

Among the "Dont's" we read with pleasure, "Don't be penny wise and pound foolish, and cut his office force down so that he will have to devote any part of his time in the office to making out statements, telling how it was. Don't believe that the average successful shop foreman will make the most desirable round house foreman. There are too many tricks in the trade they don't know about, and in these days when economy is desirable it is too costly.

Select your man carefully, back him up, help him, for the keynote in efficient operation is the successful roundhouse foreman of 1904.

Electric Headlights.

"There is room for improvement in electric headlights," is the concluding sentence of a paper on "Electric Headlights" submitted to the Western Railway Club by Mr. J. A. Carney, master mechanic of the Chicago, Burlington & Quincy. The assertion was made, however, that the electric headlight as an adjunct to modern railroad practice has a great many advantages and some deficiencies. As a warning to the public who may have occasion to cross the right of way at grade, its value is almost without estimate.

Some years ago a railroad running through a prairie state put on a high speed train leaving a terminal about 9.30 P. M. Electric headlights were not used at the time of its installation and there were a number of highway crossing accidents. The engines running the trains were afterwards equipped with electric headlights and the crossing accidents stopped.

A man approaching a railway crossing and hearing the whistle would say to himself, "Freight, plenty of time," and get on the track about the same time the engine reached the crossing. The electric headlight is a warning to the public that a high speed train is approaching and they exercise more care.

An electric headlight burning in a switching yard is a nuisance, and it almost obliterates hand lanterns and switch lights that come in its field, and at many division points it is the rule to shut down the light while the engine is waiting for its train.

According to the author of the paper

the effect of the diverging rays of light have a blinding effect upon the vision of the engineman during heavy snow and rain. By placing a circular extension in front of the headlight a decided improvement was effected.

In discussing the electric headlight as a safety appliance we were surprised that Mr. Carney did not bring out its use in preventing collisions in cases where orders are misunderstood or lap orders given. That seems to be one of the strong points of the electric headlight.

The Third Law of Motion.

Have you ever thought why it is that when the propeller of a steamer revolves, in the water, the vessel moves. If the propeller, or screw, turns to the right, like the hands of a clock, the ship is usually forced ahead. We can see the water churned into foam and driven away from the stern, but that does not account for the motion of the ship. If the water offered no more frictional resistance than it does, but was less easily tossed about by the propeller blades, the ship would move the faster. If the liquid in which the ship floats was as thick as butter and yet produced no more friction than water does, there would be practically no slip to the screw, and the ship would go ahead at each revolution, a distance about equal to the pitch of the screw.

The resistance of the water to the propeller action is what makes the ship move forward. The water objects, so to speak, to being driven back and away from the stern and it exerts a pressure upon the revolving screw, and this pressure tends to drive the propeller itself forward, and cause it to crash into the stern plates of the ship.

At the front end of the shaft, near the engines, is placed the thrust bearing or pillow block. On the portion of the shaft within this bearing there are several square faced collars, and these fit into depressions in the bearing. When the pressure of the water tends to make the propeller beat its way through the stern, and shove the shaft toward the bow, the collars of the thrust block resist this dangerous motion, and keeping shaft and propeller where they belong, transfer the motion to the whole ship.

The movement of the ship is then the result of the mutual action of two bodies on each other which are always equal and exerted in contrary directions. That is one way of stating Newton's third law of motion. If any body presses or draws another, it is just as much pressed on, or drawn, itself by the second body.

Almost anyone if asked how much does a table press up on a 2 lb. hammer laid on its surface, would, without thinking, probably reply, "Nothing at all," forgetting that the table presses up as much as the hammer presses down.

The third law of motion amounts briefly to this: "Action and reaction are always equal and opposite."

A curious example of how evolution takes care that the action of the "third law" shall not harm certain birds of strong and rapid though sometimes irregular flight, was given by Mr. C. J. Maynard at a recent meeting of the Boston Scientific Society. The wishbone, as we call it, or the furcula, as they speak of it in Boston, is really, in a bird, the union of the two bones, which correspond to the collarbones in man. The wishbone receives the pressure caused by the wing strokes of the bird in flight. Birds, like the eagle, whose wing strokes are powerful, and where the bird is in the habit of turning suddenly to the right or left, put a heavy strain on the wishbone. The strain is greatest when the bird is making a sharp turn, for then the wing pressure is all on one side.

The eagle's wishbone has become a solid round arch capable of sustaining considerable end thrust without buckling or springing or allowing the wing to drive in on the breast, as would be the case with a slender, sharp pointed bone, such as the spring chicken has and which we are all familiar with. We have often seen two people break this sharp pointed bone after dinner to see which shall have the most of the merry thought. The eagle's arched wishbone would not yield in that way to an easy pull.

It is interesting to trace the action of Newton's third law of motion to the movement of the locomotive along the track. The third law is involved in why an engine moves, but the solution of the problem has already been given several times in these columns.

Explosion of a Piston.

We have received from Mr. G. R. Henderson the following extract from a letter which he received:

"A machinist was heating the head for the purpose of removing it from the piston rod, and while doing so the head exploded. It seems he had not removed the core plugs from the head; the machinist who was working on the job had his eyes blown full of dirt and after a few days in the hospital was able to resume work again, but the gang foreman, who was making a sketch of the heating apparatus, was killed instantly, and a machinist who happened to be passing at the time was struck in the legs with flying pieces of the head and after being in the hospital about three weeks, died from the effects of the injury."

We have repeatedly published notes concerning similar accidents, and workmen cannot be too careful in their efforts to remove piston heads. Care ought always to be taken to provide a vent to the steam before a piston head is put

upon a fire. This caution, if heeded, may prevent some poor fellow from getting injured.

Brotherhood Souvenir.

"Los Angeles 1904" is the title of a unique souvenir which has been brought out by the Grand International Brotherhood of Locomotive Engineers, as a memento of the sixth biennial convention of that order held in that metropolis of Southern California.

It is practically a book of views and contains some of the most wonderful scenes in the world which are to be looked at only in the Golden West. The committee of arrangements with Mr. E. Stevens as chairman, and Messrs. R. C. Martin, R. W. Kelly, G. E. Hughes and E. C. Jordan, members, have turned out a most creditable piece of work in this publication.

The descriptive matter tells something about the early history of California and of Los Angeles, a city which was founded in 1781 and said to have had a mixed population, at that time, of 46 persons, while to-day it has a population of about 150,000. There are upwards of two hundred and fifty half tone illustrations, and they are of excellent quality and are printed on specially good paper. The oil industry of Los Angeles comes in for more than passing notice and a wonderful view is given of the submarine oil field at Sumnerland, Cal.

Some of the other scenes included in the book are the semi-tropic ostrich farms along the Southern Pacific, the big trees of Mariposa county and the Yosemite Valley. The book will be prized by those who have been to California.

A Wise Man Blunders.

James Watt, the famous engineer and inventor, established many facts concerning the steam engine, and he left his mark upon the steam engine as no other single man has done, but he made some curious mistakes. He insisted that no steam engine could be made a success without using a condenser, and he opposed the idea of using a steam engine for land locomotion. By experiment and experience he found the best piston speed of condensing engines to be about 220 feet per minute, and for many years the engineering world fell into serious blunders in trying to keep down the piston speed of engines to suit Watt's rule. Even designers of locomotives labored to restrict the piston speed of their engines and it was only after many expensive mistakes were paid for that American engineers found out that under certain circumstances piston speed double or treble that of Watt's rule was more economical of steam than the lower speed. There is less cylinder condensation with the high speeds than with the slow moving piston.

Questions Answered

(51) L. C. B., Cape Charles, Va., writes:

We have a locomotive on our road with a 10½ Wm. Sellers injector on the right side, it has been in service about three months and has been working all right. One day lately when arriving at roundhouse engineer reported injector not working. It was given a good overhauling, nothing cleaned and everything put back just as it was. Boiler check was all right, new tank hose put on. It would not work with 6 ins. of water in the tank, the injector on the other side was same make, etc., and would work at any water level. The right injector, however would work with tank full. What was the trouble? A.—If, as you say, nothing was cleaned out when injector was taken down, we assume that it did not require cleaning, and that it was perfect in all its parts and everything fitted properly and tightly. The injector was drawing air at some point. When the tank was full the weight of water was sufficient to make a small leak outward, but when water was low the pressure was not sufficient to do this, and the injector drew air and broke.

(52) F. A. H., Susquehanna, Pa., writes:

Will you please explain what is the correct way for the eccentric rods to be coupled to the link in a direct motion engine? There has been an argument here on this question. Some say the forward motion eccentric rod should be coupled to the bottom of the link which would make the rod "cross arms." We have five compound ten-wheel engines on our road and they are coupled just the same as the indirect motion. How should it be done? A.—This matter is described and illustrated on page 263 of our "Twentieth Century Locomotives," which is just out. In the engine you speak of, viz., the direct connection engine with an ordinary D-slide or outside admission valve, the forward eccentric rod should be coupled to the bottom of the link. In the case of the five compounds they probably have inside admission piston valves and are connected as you say. It is most important when studying this subject not to lose sight of the fact that outside or inside admission valves are just as important in determining the position of the eccentrics as direct or indirect motions are. For example, take an engine on the forward quarter with piston close to the front cylinder cover; it is usual to lower the link in order to produce forward motion of the engine, or, in other words, you want to be able to put the reverse lever in the corner ahead in order to go ahead. The valve in any case must move so as to open the port, otherwise you will not

get any movement of the engine. You can by examining easily tell which is the go ahead eccentric. Having found it you must couple it so that you can get the required forward motion of the engine when the reverse lever is in the extreme forward notch. In this explanation one side of a locomotive is only considered. In an ordinary engine when the piston is at the front end, the valve must be back of its mid-travel to be open on the front port the amount of the lead so as to supply steam, and must be traveling backward to continue the opening of the port. If the valve is of the inside admission type it must be forward of its mid-travel to be open on the front port and must be traveling forward to continue the opening of the port.

(53) W. W. H., Glasgow, Mont., writes:

We have some 18x26 in. cylinder passenger engines that carry 210 lbs. steam. They run in a level country. How should the valves be set for speed with or without lead, and how much? A.—When an engine has valves set purposely for speed, it is assumed that she will not be overloaded. The engine in question could be given ¼ in. lead, and if the valve travel is about 5 or 5½ ins. then ⅞ in. lap. If the valve travel is greater the lap might be increased. For very high speeds ¼ in. inside clearance would help.

(54) R. L. S., Stratford, Ont., writes:

The intercepting valve spindle that the reducing sleeve works on, of the Richmond compound locomotive, is provided with "water packing grooves." What results are obtained from these grooves? A.—The grooves are, as you say, water packing grooves and are designed to prevent leakage. The spindle is made to fit snugly inside the reducing valve but is yet capable of motion and the water grooves keep the spindle and valve practically tight at all times.

(55) J. D. P., Eureka Springs, Ark., asks:

(1) What is a ton mile? A.—The expression ton mile means the gross weight of the train multiplied by the number of miles traveled. For instance, a train weighing 850 tons, hauled 125 miles would be equivalent to 106,250 ton miles. That is, the work done theoretically equals that number of tons hauled one mile. (2) What is the formula for figuring consumption of coal by tonnage? A.—There is no special formula beyond ordinary arithmetic for this. If an engine burns 10 tons of coal making 1,000 ton miles, it is clear that one ton of coal is burned for every 100 ton miles made. This is found by dividing the total number of ton miles by the number of tons of coal burned while doing the work.

Soft Water.

The Kennicott Water Softener Company, of Chicago, have issued a standard 9x12 ins. pamphlet describing their water softening installation on the Pittsburg & Lake Erie Railroad. The total treating capacity of this plant is 348,000 gallons per hour. The road is 194 miles long and upon this amount of track about 98,789,694 car miles were made last year. In order to do this many 3,500 ton trains had to be hauled. The quality of the water was practically a fixed thing, as the Ohio, the Monongahela and the Youghiogheny rivers were the only available sources of supply. The railroad company was therefore compelled to use these waters, which not only contained large quantities of sediment but also held scale forming salts, and in some cases free sulphuric acid.

It is needless to say that constant boiler repairs and excessive shop time was the handicap imposed upon the motive power department previous to the use of water treated after the Kennicott system.

A waste of fuel was always going on due to driving heat through the incrustation which formed on flues and fire box plates. A scale $\frac{1}{8}$ of an inch thick makes it necessary to use 15 per cent. more fuel than if the scale was not there.

The loss of service of locomotives on this road, due to bad water conditions, was estimated at $\frac{1}{2}$ of the total time in which they might have been used in profitable service, and the cost of what may be called the "bad water" boiler repairs was computed to be about \$100 per engine per year, making in this case a total loss of \$20,000 per year.

The Kennicott Water Softener Company, Railway Exchange building, Chicago, will be happy to give further information on this very interesting and important matter to those who will write to them for it.

Handy Shop Tools.

The detail drawings here shown are of handy tools used in the Sayre shops of the Lehigh Valley Railroad. Fig. 1 is a sectional view of a right angled drill used for drilling holes through the barrel of the boiler from the flue sheet, preparatory to riveting. It is driven by an ordinary electric motor. The end screw can be detached in an instant by the pawl and is locked when the handle is in a reclining position, as shown. This permits any length of drill to be used and regulates the pressure on the drill.

Fig. 2, the view in the right upper corner of the cut, shows the drill attached to a wrought iron ring with $\frac{3}{4}$ in. holes spaced equal distances apart, to which the drill is bolted in place, but the clamps on the drill permit it to travel around the periphery of the ring with-

out detaching until the entire drilling is accomplished. The ring is $\frac{1}{2}$ in. thick, $3\frac{3}{4}$ ins. wide and its outside diameter measures 27 ins., and it is at-

looking on the face of Medusa, the Gorgon, into a mountain, upon which rested the heavens. Atlas was always associated with a heavy burden strong-

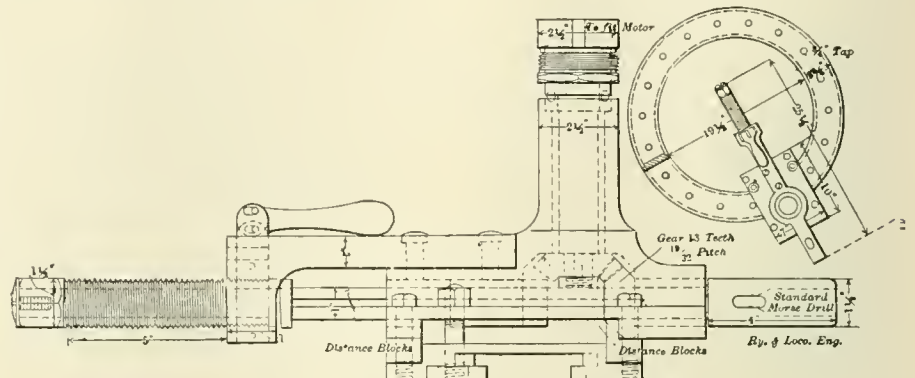

FIGS. 1 AND 2.—SECTIONAL VIEW OF RIGHT-ANGLED DRILL.

tached to a convenient place on the flue sheet.

Fig. 3 shows two views of a keyway cutter and its mode of attachment to axles whose wheel centers have already been pressed on the driving axle. The chains which pass round the axle have T-headed bolts which fit into holes in the body of the machine and the vise

ly and constantly borne, and it is not difficult to see how, by an association of ideas, this came to be considered as appropriate for the name for a book of maps, which exhibits to us the world as if held up before us.

Our most popular valve motion model is receiving a very gratifying reception

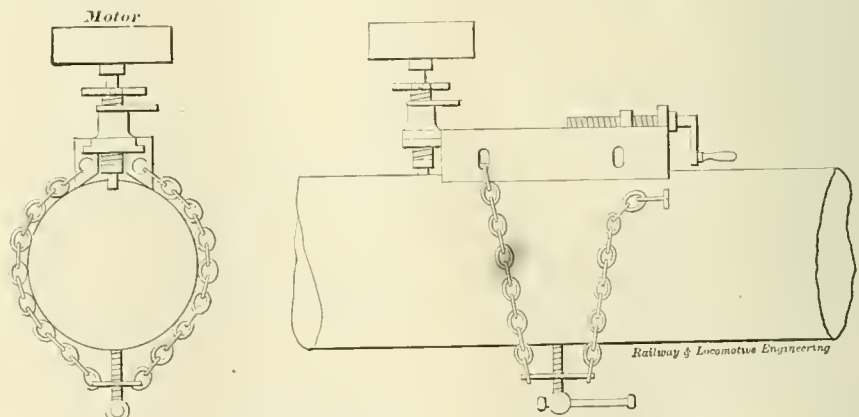

FIG. 3.—KEYWAY CUTTER OPERATED BY A MOTOR.

screw below tightens it up and holds the machine so that it cannot slip. An electric motor revolves the vertical cutter, which is fed along by hand.

What the Word "Atlas" Means.

Strictly speaking, "atlas" is something of a misfit for a map book. The demi-god Atlas of mythology upheld the heavens. Mercator, the famous Dutch geographer, was the first to use the name in connection with a book of maps, choosing it as in some sort an appropriate title, because Atlas, the demi-god, figures with a world upon his shoulders as a frontispiece of some early works on geography. Atlas made war with other Titans upon Zeus or Jupiter, and, being conquered, was condemned to bear the heavens upon his head and hands. Later tradition represented him as a man changed, by

and the demand for it keeps steadily up. It is of very convenient size, being 29 ins. long over all. It is 11 ins. high and the cylinder is $3\frac{1}{4} \times 4\frac{1}{2}$ ins. The travel of the valve is 1 in. and the length of the link slot is $4\frac{1}{4}$ ins. One novel and valuable feature about the model is that by loosening two screws and uncoupling the valve spindle a piston valve of the inside admission type may be put in place and eccentrics adjusted to suit the new conditions. No extra charge is made and each model has D-slide and inside admission piston valves.

The Edwards Railroad Electric Light Company have moved their offices from Cincinnati, O., to Chicago, Ill., suite 1217-19, Monadnock Building. They will be pleased to see their friends in their new quarters and request that all correspondence be sent to Chicago.

Air Brake Department.

CONDUCTED BY F. M. NELLIS.

The Air Brake Convention.

(Continued.)

THIRD DAY'S SESSION.

The third day's session opened up with President Desoe in the chair.

The first paper presented was that by S. J. Kidder on "Electric Car and Train Brakes." Mr. Kidder reviewed the development of the street car brake, beginning with the small horse car and end-

on the part of the inventors, have not proven sufficiently meritorious to find a field of prominence as a power brake in electric car braking.

"Next in order comes the compressed air brake, which is being rapidly introduced on motor-driven railway cars, and proving the most efficacious of those yet commented on.

"It would thus appear that the history of power brakes for the cars under con-

form, having one or more main reservoirs, a brake cylinder, in which the air exerts its energy in applying the brakes through the foundation brake gear usually employed in air brake practice, one or two engineers' brake valves, or, more properly speaking, motorman's brake valves, and an air gauge denoting main reservoir and brake cylinder pressure—the above arrangement being common to the three types of brakes known as stor-

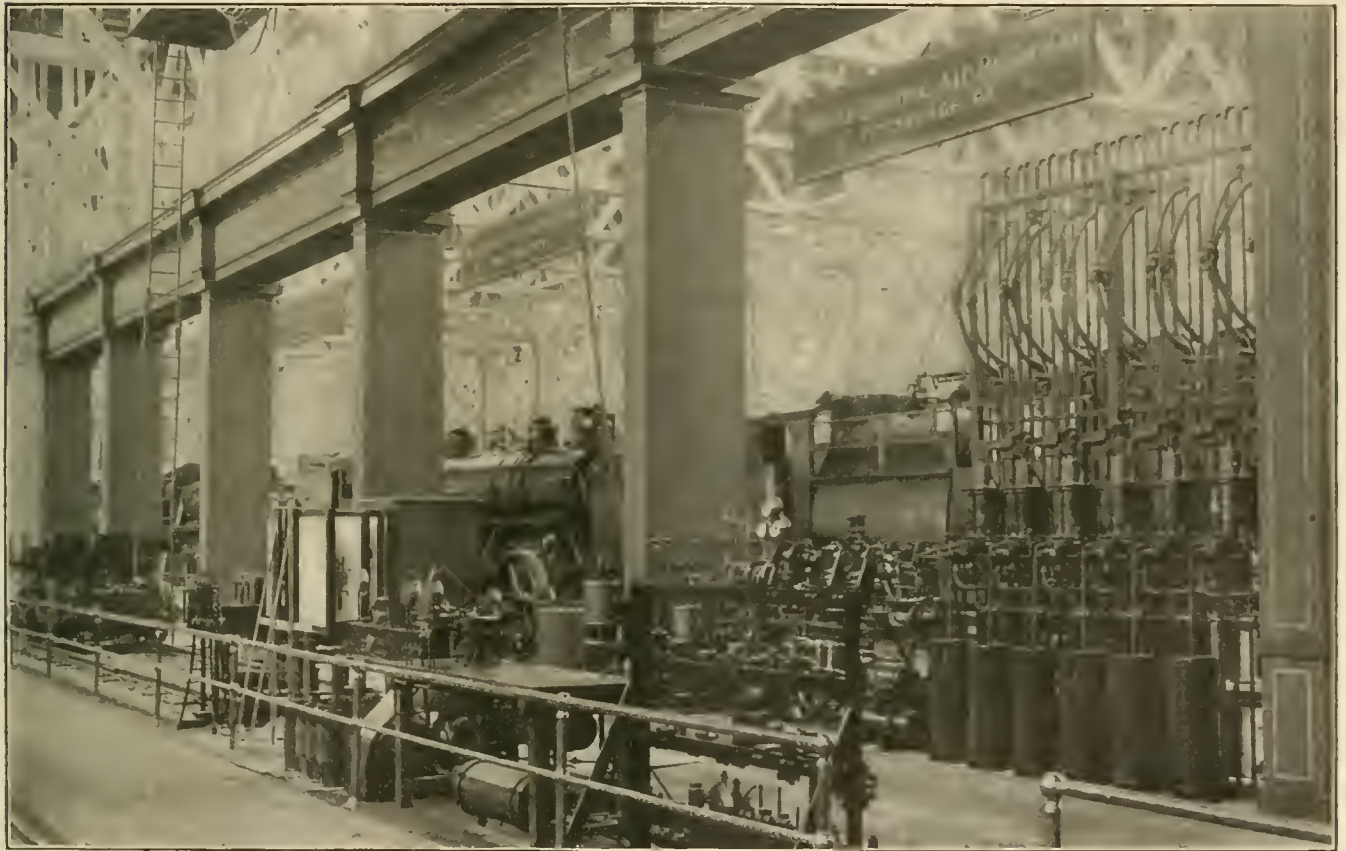

WESTINGHOUSE AIR BRAKE COMPANY'S EXHIBIT, WORLD'S FAIR, ST. LOUIS, MO.

ing with the large, heavy interurban and elevated car. He said in part:

"The first, or friction brake, does not appear of sufficient importance to demand extended consideration, not much having been demonstrated in its favor, it appearing that first cost is about the only thing to invite its serious attention, and it will never attain standing as a power brake in connection with motor-driven cars.

"Hydraulic brakes have been experimented with and used to some extent, and, while they exhibit no little ingenuity

consideration is but a repetition of that strived for at a more remote period for steam roads, and that compressed air still leads the van in attaining decided prominence as the most practical and efficient agent for operating such brakes. Unlike the steam roads, however, we find that in connection with street or electric car braking, straight air can, in many instances, be profitably employed, particularly where the motor car is operated without trailers, such as is usually the practice on street and surface roads.

"The straight air brake is of the usual

age, axle driven and motor driven systems.

"With the storage system one or two main reservoirs of liberal capacity are used, the same being charged at a central storage plant to a pressure of from 275 to 300 pounds, the plant being able to replenish the car reservoirs through suitable hose provided with couplings for convenience in making the connections, in from 10 to 15 seconds. These storage system cars also usually have a smaller reservoir, perhaps 12x33 ins. in dimension, located between the main reservoirs

and brake valves, this smaller reservoir furnishing an abundance of air for an emergency application of the brake quite independent of the somewhat restricted capacity of the reducing valve to quickly supply the air required. Interposed between the pipe connecting the storage and

yet as thoroughly taken up and understood as the steam part has been.

At this point Mr. J. F. Deems, general superintendent of motive power rolling stock and machinery on the Vanderbilt lines, addressed the convention. Opening in a happy vein, Mr. Deems proceeded to the more serious contemplation of the work of the association, its past performances and its future responsibilities. He believed this work to be one of the most important on railroads, since the stopping of trains has been left entirely to the air brake men; also the maintenance and care of this stopping power which controls the speed and contributes to the safety of the thousands of passengers daily traveling on our high speed trains. He touched on the rapid development of the air brake art, stating instances which comparatively a few years ago was not unusual, of stage coach traveling, etc. He contrasted this with the fast, luxurious travel of the present day, which travel wholly depends upon the air brake to make such high speeds possible. No doubt his words gave in-

The subject of one and a quarter inch hose for all classes of cars was next taken up, and the consensus of opinion seemed to favor the adoption of such a practice, although some minor objections were stated against the plan.

The convention adjourned with the

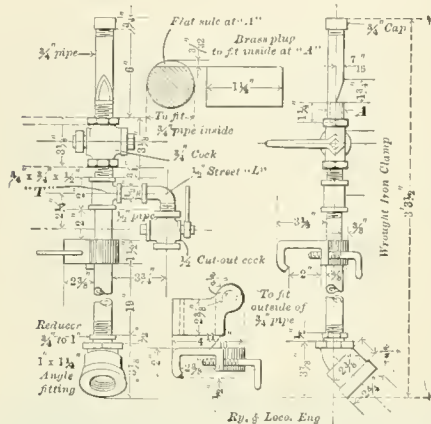

"BACK-UP" HOSE AND CONNECTIONS USED ON LEHIGH VALLEY R. R.

12x33 in. reservoir is the reducing valve, just referred to, set at the maximum pressure intended to be permitted in the brake cylinder, thus providing a safeguard against the motorman, subjecting the brake cylinder to a higher pressure than intended. A further provision is a safety valve in the low pressure reservoir adjusted somewhat higher than maximum brake cylinder pressure to prevent abnormal accumulation of air in the small reservoir in the event of leakage past the reducing valve.

For the axle driven and motor driven systems the arrangement of apparatus and stored power is substantially the same as that just described, with the ex-

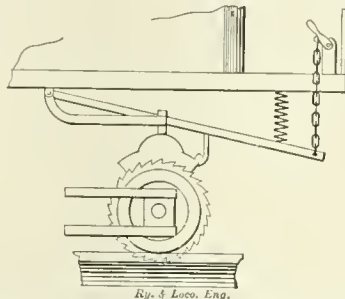

A RECENTLY INVENTED BRAKE. WHEEL FLANGE IS NOTCHED TO RECEIVE BRAKE SHOE. NO RAILROAD MAN INVENTED THIS.

creased encouragement to the members present. Such words go far to encourage and make an association a success.

W. O. Thompson, superintendent motive power, New York Central & Hudson River Railroad, and secretary of the Traveling Engineers' Association, also addressed the convention in the same spirit. Such talks contribute largely to the encouragement of an association of this character.

THE FRICTION OF BRAKE SHOES.

The paper on the "Friction of Brake Shoes," by Robert H. Blackall, was next taken up. In the absence of Mr. Blackall the paper was read in abstract by Mr. F. W. Sargent, who gave an exceedingly interesting and valuable discourse on the subject of brake shoe friction. So complete was the paper and so thorough was the explanation of the subject by Mr. Sargent that a discussion thereon was deemed superfluous. The paper was accepted with many thanks to Mr. Blackall and Mr. Sargent, who had thus contributed undoubtedly the most valuable paper on brake shoe friction yet presented to air brakemen.

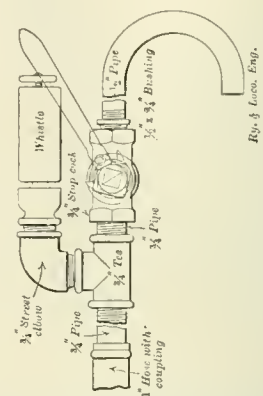

"BACK-UP" HOSE USED ON THE MICHIGAN CENTRAL RY.

election of officers, which resulted as follows: President, John Hume, Jr., Houston, Texas; First Vice President, L. M. Carlton, Chicago, Ill.; Second Vice President, W. P. Garbrant, New York; Third Vice President, T. L. Burton, New York; Executive Committee, J. W. Hardy, Colorado Springs, Col.; P. J. Langan, Scranton, Pa.; J. W. Alexander, Altoona, Pa.; Treasurer, Otto Best, Nashville, Tenn.; Secretary, F. M. Nellis, New York.

At 2:45 P. M. the men of the convention boarded the local New York Central train for Niagara Falls, where they met the ladies, who had preceded them in the morning, and a trip down the Canada side and back, via the Gorge route, was taken.

The Committee on Arrangements reports:

"Through the courtesy of Mr. G. C.

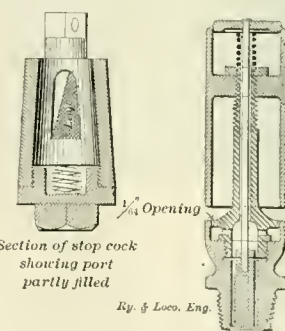

DETAILS OF "BACK-UP" HOSE DEVICE USED ON THE MICHIGAN CENTRAL RY.

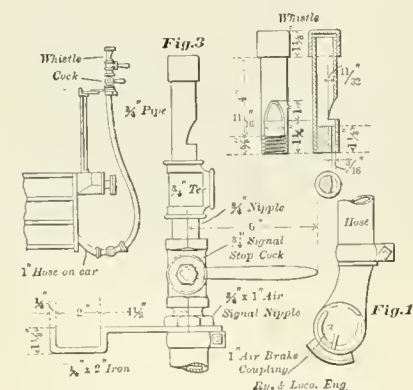

"BACK-UP" HOSE AND CONNECTIONS USED ON THE CHICAGO & NORTH-WESTERN R.R.

ception that a more moderate pressure is maintained in the main reservoir, the air being furnished from a pump or compressor forming a part of the apparatus on the car."

The discussion following the reading of the paper was rather limited, inasmuch as this subject is new to the members of the association, this branch of air brake business not having been as

Jones, the superintendent of the Grand Trunk Railway, many members of the Air Brake Association and their ladies in attendance at the Air Brake Convention in Buffalo were given a most enjoyable trip on Friday, May 13, from Buffalo to Toronto and return. The special train, which was composed of a modern

Grand Trunk railway locomotive and three of the above company's beautifully finished coaches, equipped with high speed brakes and other special safety appliances, left Buffalo at 8:10 A. M., accompanied by Mr. Price, superintendent of transportation; Mr. W. Kennedy,

Correspondence.

The New York Duplex Brake Valve.

In the description of the New York Duplex Straight Air and Automatic Brake apparatus, June number, it is stated that a brake valve of special design is required so that the automatic brakes, upon the train, and the straight air brakes, upon the engine and tender, may be applied simultaneously with one and the same movement of the brake valve handle.

It will be worth while, therefore, to study the design and construction of the duplex brake valve which permits of the two types of air brakes being operated simultaneously.

In order to do that, we present here four figures of the Duplex Straight Air and Automatic Brake Valve, Style D, as it is known.

Figure 1 is a vertical section through the handle, body, and lower portion of the brake valve, showing the construction of the brake valve handle, with its latch, spring, and set screw; and also shows the rotary valve, with its key and handle stem, together with the straight air brake pipe, automatic brake pipe and main reservoir pipe connections. The air gauge connections are made direct to the automatic brake, the straight air brake, and the main reservoir return pipes.

From the air gauge pipes, as shown in the piping diagram, other pipes branch out of tees to the duplex pressure controller, and to the Y cock.

Figure 2 is a plan view, looking down down upon the top of the brake valve, and shows the manner in which the brake valve is fastened to the boiler bracket; it also shows the various positions for the brake valve handle, the arc through which the handle swings from release to lap, and from lap, through graduating service, to emergency position.

The dotted lines in this figure indicate the brake pipe, and main reservoir ports and passages, and the exhaust opening to the atmosphere. It will be observed that a single exhaust opening serves for both the automatic and the straight air brake, since but one kind of brake will use this opening at one time.

Figure 3 is a plan of the valve face, showing the design of the valve and the arrangement of the ports and cavities in it through which main reservoir air flows into and out of the brake pipes. Figure 4 is a plan of the seat upon which the valve rotates.

The different ports are marked so that it may be easily seen where they conduct the air to in the duplex system.

The ports to the brake pipes are triangular shaped so that a graduated application of the brakes may be made with ease, such as is required in service; or they may be applied instantaneously, with full force, as is necessary in emergencies.

The triangular shape of the port (leading to the automatic train pipe) renders it easy to operate the automatic brakes on a long train satisfac-

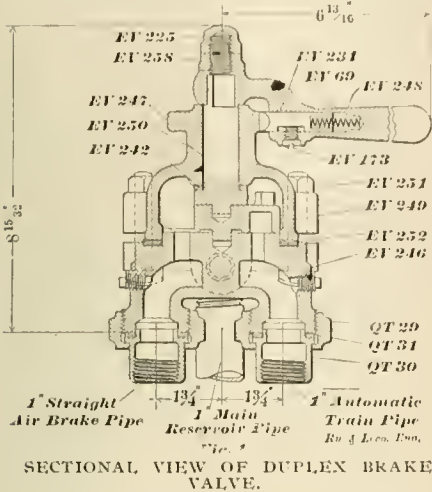

SECTIONAL VIEW OF DUPLEX BRAKE VALVE.

master mechanic, and Mr. Black, traveling engineer, all of the Grand Trunk Railway.

"The distance, 105 miles, was covered in remarkably short time and the party were allowed to spend about six hours in Toronto viewing the many points of interest. The train left Toronto on the return trip at 4:30 P. M. and arrived in Buffalo at 7:10 P. M. This was an exceptionally fast run, considering that six stops were made, including one of ten minutes at Hamilton. Engineer Overen handled the train the entire distance and his gilt edged work, both as a runner and brakeman, brought forth much favorable comment. As the party left the

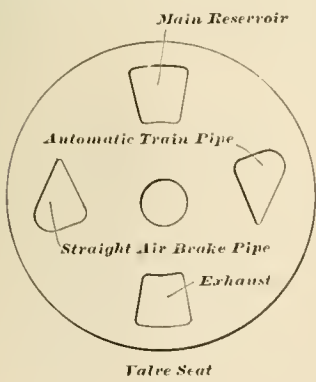

PLAN VIEW OF VALVE SEAT.

train at Buffalo, each of the 125 people presented Mr. Overen with one of their cards.

Altogether the trip was a delightful one, and the kind treatment received at the hands of Mr. Jones and his associates will be long and pleasantly remembered by those who were fortunate enough to make the trip."

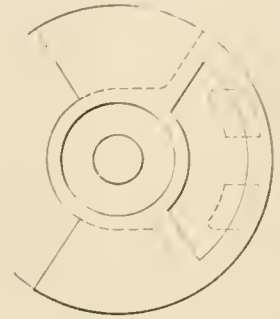

PLAN VIEW OF VALVE FACE.

torily without an equalizing discharge valve in the brake valve.

An easy way to determine just how this valve operates is to imagine Figure 3 placed directly over Figure 4 so as to rotate; then it will be seen that the triangular port for the straight air brake is opened for the admission of main reservoir air to the driver and the tender brake cylinder, and, at the same time, the triangular port for the automatic brake pipe is brought under the cavity in the rotary valve leading to the exhaust port, thus providing for the simultaneous application of both the automatic and the straight air brakes.

There is little to be said in the way

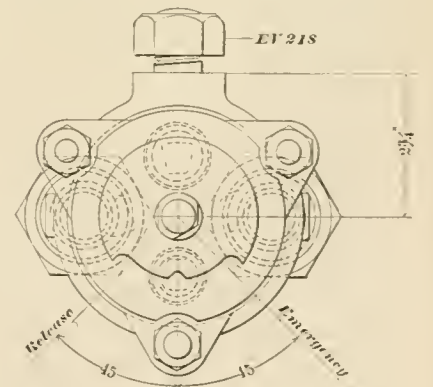

PLAN VIEW OF DUPLEX BRAKE VALVE.

of instruction for the operation, care, and maintenance of this brake valve; it is of the rotary type, simple, and needs only the same attention that the other types of brake valves require.

J. P. KELLY.

Watertown, N. Y.

Automatic Air-Cylinder Oil Cup.

An automatic oil cup which will efficiently and reliably lubricate an air cylinder under conditions where it is subjected alternately to compression and partial vacuum has been sought after for many years. In railway service the air pump is usually placed along the right or left side of the locomotive in a position very difficult of access, while the locomotive is running and consequently considerable time elapses between opportunities for readily ascertaining the condition of lubrication on the air end of the pump. For such service an automatic lubricating device is especially needed.

The Westinghouse Air Brake Co. have recently perfected an automatic air cylinder oil cup of a design which fulfils the exacting requirements of such service in a perfect and reliable manner. The cuts herewith show clearly the construction of this oil cup. Briefly speaking it has a brass body having a chamber in which the oil is placed. The small regulating valve stem which passes down through this chamber can be easily adjusted from the top by simply pulling out the cap which fits into the top of the

itself so that no air can be discharged to the atmosphere through the oil cup. In this way the oil itself is subject to atmospheric pressure only at all times. Part of the cavity into which the oil

thus on the upward stroke of the piston the compressed air is forced out, not only on top of the ball valve, but also into the groove canal in the base and thence to each of the vertically drilled passages in the body. As the temperature of the compressed air is always high, it is sufficient to heat the oil cup so that the oil is liquid even in the coldest weather; and as the oil has to withstand the temperature of this compressed air upon entering the cylinder, it cannot be harmed by any temperature that may be attained by the oil cup due to this compressed air being forced into it.

The chamber containing the charge of oil holds about two ounces. The amount that should be fed to the pump cannot be stated for all conditions, but it has been found that in cases of continuous operation for ten hours at a time one drop of oil a minute is ample. In such cases the amount of valve oil held by this cup is equivalent to several hours' continuous operation without attention.

It will be noted that this oil cup is designed to be used in the same posi-

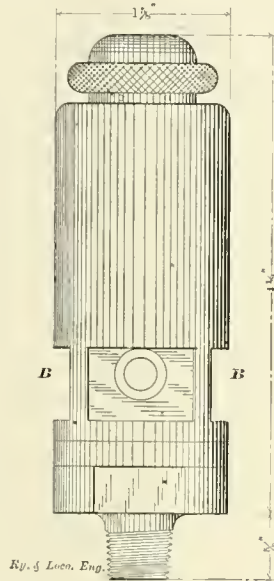

EXTERIOR VIEW OF AUTOMATIC SIGHT FEED OIL CUP FOR AIR CYLINDER AT PUMP.

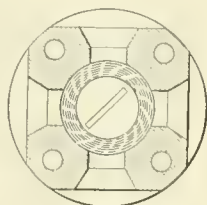

Section B-B

HORIZONTAL SECTION OF OIL CUP.

drops is formed of a piece of glass tubing, and four holes are placed in the brass body so that one can look through and see the rate at which the oil is feeding. In other words the design in this particular constitutes a simple sight-feed oil cup.

It will be seen in the sectional views of this cup that four holes are drilled up through the body; these are connected

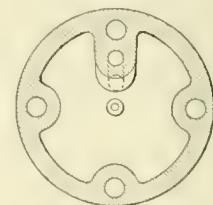

Section A-A

Ry. & Loco. Eng.

HORIZONTAL SECTION OF OIL CUP.

body and is fastened by a chain so that it cannot be lost. A small lock-nut on this valve stem insures against the feed regulation changing. When this valve is raised slightly, the oil passes drop by drop into the small chamber just below. This chamber connects by a passage the body up to the cap and through small holes in this cap to the atmosphere; thus it is always under atmospheric pressure. It also connects to the bottom of a steel ball valve. It will be noted that the upper part of the cavity in which this ball valve is placed connects by a similar passage to the air cylinder.

Consequently when the air pump piston descends, the suction causes the ball valve to rise and air will be drawn down through the passage in the body and the holes in the cap. As air is drawn into the pump cylinder, any oil that may have dropped from the regulating valve onto the top of the nut which holds the ball valve in position is drawn down into the pump cylinder and performs its work of lubrication. As soon, however, as the air piston starts on its return stroke the ball valve promptly reseats

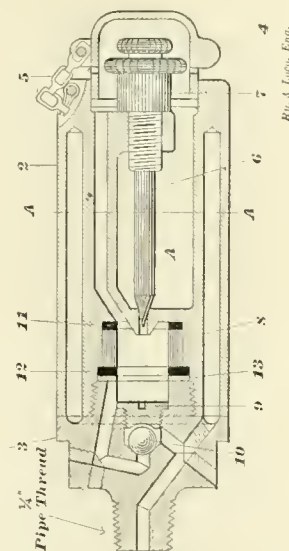

SECTIONAL VIEW OF OIL CUP.

with a circular groove in the steel base, so that all four are in communication. This groove also connects with the drilled passage leading from the pump cylinder to the top of the ball valve;

tion as the old one, but is slightly larger. It can, however, be adapted to any pump in service except the eight inch pump without requiring any alteration other than simply removing the old cup and inserting this in its place.

Sand Blower and Brake Attachment.

I have been granted patents on a sand blower and brake attachment, the operation of which is as follows:

Air from the main reservoir (not shown) passes through the pipe A (Fig. 2) and by its pressure holds the valve B firmly in its seat. By turning the handle F (Fig. 1) the valve D can be set so as to open a passage between the chamber E' and either C' or C'', so that sand will be thrown upon either the front or back side of the driving wheels, the pipe through which sand is distributed depending on the direction in which the engine is running. When the handle E is on "running" or "release" position, the valve E' (Fig. 1) is closed. When the handle E reaches "on lap," the plug D' will contact with the nut D'' and through

the medium of the rod D³ will rotate the handle G and valve B, and the sand will commence to run, and when the handle E reaches "service stop" the air passes through the opening E⁵, bore E¹⁰, chamber E⁷, opening E⁶, and pipe C³ or C⁴, throwing sand into either the front or back pipe. On moving the handle E to the "emergency stop" the valve E² will be opened to its full extent and sand will

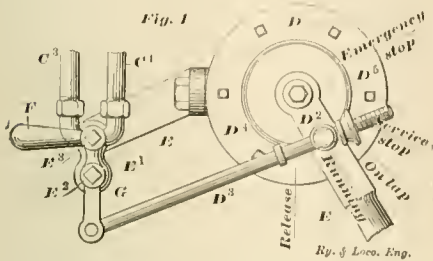

SAND BLOWER AND BRAKE ATTACHMENT.

be delivered in increased amount to the track. Should gravel or the like accumulate between the nozzles and the inner ends of the sand pipes in the sand box, the ordinary sand lever is drawn, drawing out the slides, and the accumulated gravel will pass down through the ordinary sand pipes to the track. The distance through which the handle E can be moved without shutting off the valve E² can be regulated by adjusting the nut D³ on the rod D³.

J. D. SMITH,

McDonoughville, La.

QUESTIONS AND ANSWERS

ON THE AIR BRAKE.

(53) A. L. M., Harrisburg, Pa., writes:

An engineer tells me when coupled to a train his whistle operates O. K., but

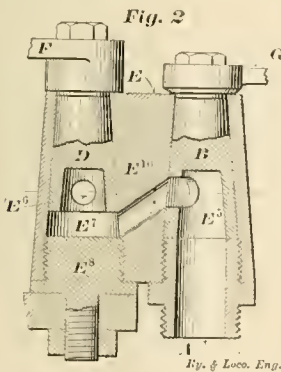

SAND BLOWER AND BRAKE ATTACHMENT.

when double heading either ahead or next to train his whistle will not operate. On a test of whistle line pressure it is found his reducing valve closes at 65 lbs., while the other engine carries 44 lbs. I cannot see that this would have anything to do with the operating of the signal valve. Will you please give me an answer to satisfy several inter-

ested engineers. A.—The trouble is doubtless traceable to the condition of the whistle valve itself, rather than to the reducing valve. If the whistle will sound properly with a light engine, and also when the single engine is coupled to a train, but does not perform properly when another engine is added, the trouble is probably due to the whistle valve not being sensitive enough. If this engine be placed ahead of another engine in double heading, as you describe, the discrepancy in the two reducing valves will not interfere with the blowing of the whistle. Neither will it effect it if this engine is placed second. The whole trouble is most likely due to either the whistle valve stem being somewhat worn, or the car discharge valves not being entirely free from dirt, thereby preventing a free discharge of air from the signal line.

(54) G. H. M., Elmira, N. Y., writes:

On page 16 of the Standard Examination Questions and Answers, the auxiliary end of the slide valve has a square white spot. A claims it represents the corner cut away from the slide valve, and B claims it represents the port from the auxiliary to the cylinder when in emergency. Which is right? A.—In the illustration mentioned the valve is shown with the corner cut away. A is right in respect to this particular illustration, but both A and B are right inasmuch that some triples have the corner of the slide valve removed as shown in the cut mentioned, while others do not have the corner removed, but have a port drilled to the end of the slide valve and connected with the port leading downward through the port to the brake cylinder.

(55) G. E. W., Denison, Tex., asks:

Would it be possible for the differential piston in a nine and a half inch pump to travel back far enough so that the large end of the piston would close the admission port so that no steam could get in behind the large end of the differential piston, and cause complete stoppage of the pump? This seems impossible to me on account of the limited clearance, but the statement was made by an air brake inspector. A.—With the present 9½ in. pump it is impossible for the main or differential piston to travel far enough to close the admission port. This was possible, however, with a few of the very early forms of 9½ in. air pumps, but not with the present form. You will note that provision has been made in the present standard form to admit steam pressure to the outer face of the piston, even when the piston is resting against the wall at the extreme end of its stroke. This defect mentioned was quickly recognized in the earlier form of pump and corrected.

(56) R. M. O., Rutland, Vt., writes:

A certain road runs double headers on long trains on moderate grades. Both engines are cut into the train pipe, the leading engine with the brake valve on running position and the second engine in full release, with both pumps supplying the train pipe. When coming to a regular stop, or a station, the second engineer laps his brake valve, so the head man can set the brakes. When the second man hears the flash of air out of the exhaust filling up his brake valve, he goes to full release again, and helps charge the train. Isn't that a pretty dangerous way to do? A.—This practice has been in use on some western mountain roads for a number of years, and works all right so long as no misunderstanding occurs between the engineers, and no mistake is made. But there is always an element of danger present, which might sometimes result in disaster. The better arrangement would be to have sufficient main reservoir and pump capacity on each engine to handle any train one engine can pull.

(57) J. H. M., Phillipsburg, Pa., writes:

In May number I asked why the small grooves around the supply valve piston of the slide valve feed valve were placed there. You answered that these grooves hold oil or other lubricant, thereby making a good packing to separate the air pressures on both sides of the piston. Why do we want a packing on this piston to separate the pressures, as this piston is made loose so that when the train pipe is charged up to 70 lbs. and the regulating valve closes the air equalizes in chambers E and F, past supply valve piston. Then the supply valve piston spring forces the supply piston and valve to their normal positions, thereby closing communication between the main reservoir and the train line. If there was no leakage past supply valve piston the main reservoir pressure would hold piston over and supply valve would remain open until train line would be charged entirely too high. A.—The grooves around the piston of the slide valve feed valve attachment serves to make a partial joint, but not an air tight joint, between the two sides of the piston. Of course, it is not desired to make this a positive air tight joint, but the introduction of grooves around serves to make a partial joint which will permit pressure to pass by, not holding it tightly. These grooves are used for this same reason on the piston of steam indicators, and you will doubtless remember their use on the Mason reducing valve where similar results are desired, as with the movement of the piston in the slide valve feed valve.

Growth of the Locomotive.

BY ANGUS SINCLAIR.

(Continued from page 262.)

ESTABLISHING THE GAUGE.

The history of the Erie Railroad is largely a record of financial make-shifts and disasters that began long before a rail was laid. Eight years after the company was incorporated part of the line near the Piermont end was ready for track laying. An important question then to be considered was the gauge of track. Ezekiah C. Seymour, chief engineer and a personal friend of President Lord, insisted that the gauge should be 6 ft. and he had his own way. It was an unfortunate decision as events proved, but his engineering ideas were sound. Efforts were made by influential interests to have the gauge changed to 4 feet 8½ ins. when less than 100 miles of track had been laid, but they failed and the work of changing had to be done many years later.

CURIOSITIES OF TRACK GAUGES.

One of the most curious things met with in railroad history is the influences by which certain track gauges were es-

Liverpool & Manchester Railway was under construction, the engineers concluded that it was better to give the wheels plenty of side play to make fast running easy, so they widened the gauge half an inch making it 4 ft. 8½ ins.

The success of the Liverpool & Manchester Railway and of the locomotive "Rocket" made George Stephenson a great man whose example was worthy of imitation, so his track gauge of 4 ft. 8½ ins. was adopted by most of the British railway companies. His son had locomotive building works which supplied many of our early railroads with engines, and the track gauge was frequently established to fit the wheels of the locomotives imported.

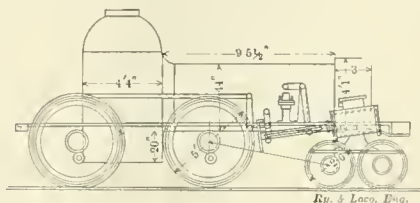

"SULLIVAN," FIRST ROGERS' ENGINE FOR ERIE RAILROAD.

When the days of railroad consolidation came about the capitalists decided to adopt the narrow gauge, which was 4 ft. 8½ ins., now known as the standard, that then having much greater mileage than any other gauge. That decision was a mistake, for the gauge is too narrow for admitting the kind of boiler a large locomotive ought to be provided with. As the locomotives used on the standard gauge are increased to their full capacity, which has already been reached in some instances, the railroad world will realize that a 6 ft. gauge would be better than the existing standard.

OPERATING OF ERIE BEGINS.

The first section of the Erie opened for business, which was in 1841, was that between Piermont and Goshen, but trains had been run for a few months previously to Ramapo. The company had purchased three engines from Norris, the Eleazar Lord, the Piermont and the Rockland. They were eight-wheel engines with Bury boilers and no cabs. The cylinders were 13x20 inches, the driving wheels about 5 feet and the Eleazar Lord weighed about 30,000 pounds, while the

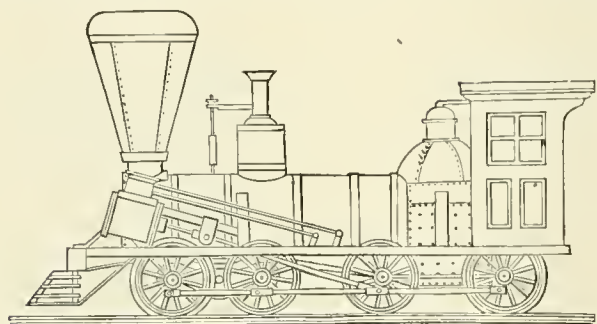

BALDWIN'S FIRST EIGHT-WHEEL CONNECTED ENGINE FOR ERIE RAILROAD.

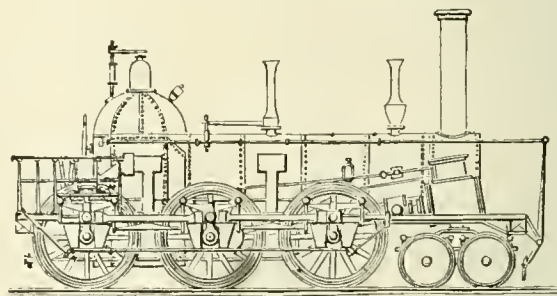

ROGERS' FIRST TEN-WHEELER FOR ERIE RAILROAD.

EARLY AMERICAN TRACK GAUGES.

established. The settling of a gauge likely to prove most convenient for the business to be done with due consideration as to cost, is an engineering problem which ought to have received careful study and profound calculation. Instead of that the gauge has been generally decided by some trifling whim or accident.

In 1840 there were 33 separate railroads in the British Isles with 1,552 miles of track and they had five different gauges, ranging from 4 ft. 8½ ins. to 7 ft.—the narrowest gauge having more mileage than all the others. That was George Stephenson's gauge, and it was established in a curious way. The gate ways of the first coal railway operated by Stephenson engines had openings just sufficiently wide enough to permit wheels to pass extending 5 ft. At that time the flange of the wheel was outside. When the Stockton & Darlington Railway was built Stephenson put the flanges inside. The width of the rail head was about 2 ins., so the inside gauge was 4 ft. 8 ins. When the

The South Carolina Railroad track was laid to 5 ft. gauge, which became that of southern railroads and continued so up to the civil war. Towards the Ohio river some of the railroads had a gauge of 5 ft. 6 ins. There was greater confusion in the North. The railroads that began by using imported engines had mostly 4 ft. 8½ ins. gauge; but there were to be found gauges of 4 ft. 9 ins. rising by inches to 5 ft. Canadian railways had 5 ft. 6 ins. gauge and as mentioned, the Erie was 6 ft.

The wide gauge was adopted by the Erie because the chief engineer believed that the grades would be so heavy in crossing the mountains that enormously large engines would be needed to haul the trains and that a narrowed gauge would not provide room for the size of boiler necessary. The president favored the wide gauge because he was opposed to the Erie having facilities of interchange with other railroads, that might be the means of diverting business from New York City.

others weighed 32,000 pounds, with similar dimensions of parts. All arrangements connected with the purchase of the first locomotives were made by George H. Hoffman, engineer of construction.

The first intention of the company had been to purchase Rogers engines, the builders being at Paterson, N. J., near the Erie line, and Rogers, Ketchum & Grosvenor had been invited to submit bids; but they wanted \$9,000 per engine and would accept no New York and Erie Railroad stock as part payment. William Norris consented to make engines for \$8,000 each and take \$3,000 in the railroad company stock, so he received the first order. He supplied two more engines, the Orange and the Ramapo, which were afterward known as Nos. 4 and 5, and were a little heavier than those previously built.

JOHN BRANDT.

About the time track laying was begun, the Erie Company engaged John Brandt as master mechanic. He had

been for several years on the Philadelphia & Columbia Railroad, and had gone from there to be master mechanic of the Georgia Railroad, which he left to join the Erie. He was an excellent mechanic and good locomotive designer, besides being an accomplished shop manager. He had organized the Philadelphia & Columbia shops at Parkesburg, Pa., and put a decided mark on improving the pioneer locomotives. He was the first man to work on the introduction of uniform screw threads for railroad machinery.

John Brandt designed a ten-wheel engine about 1843, having come to the conclusion that such an engine was necessary for the Erie grades. He tried to obtain permission to build it at Piermont, but the officials would not consent. They directed him to send the drawings to Baldwin's, which was

the place, and returned to Lancaster, where he built works for the construction of locomotives, but did not live to see them in operation.

The locomotive building works which John Brandt started in Paterson went through several hands, notably those of Smith & Jackson, and then, about 1863, became the Grant Locomotive Works. That concern attained temporary popularity in 1867 by winning a gold medal for an eight-wheel engine shown at the Paris Exposition of that year.

VARIETY OF LOCOMOTIVES THAT BELONGED TO THE ERIE.

By the time the Erie Railroad was opened from the Hudson river to Lake Erie the company appears to have had locomotives built by nearly every locomotive builder in the country. The idea of keeping railroad machinery as

reputation of certain makes of locomotives; although they were no better than others less favored. Difference in valve gear would make one engine smarter than another in starting, while a second would be noted for persistent pulling on long grades. The size of valves, arrangements of exhaust pipes and dimensions or position of draft appliances would exert a good or bad influence on the engine that would establish its reputation. Train men and others became as strong adherents of certain makes of engines and as bigoted concerning their merits as religious people become of certain tenets of faith, and were prepared to quarrel about them as blindly and as zealously.

ERIE MOTIVE POWER.

In 1853 an article appeared in the *American Railroad Journal* describing the Erie motive power of that day, which

PIONEER LOCOMOTIVE BUILDERS.

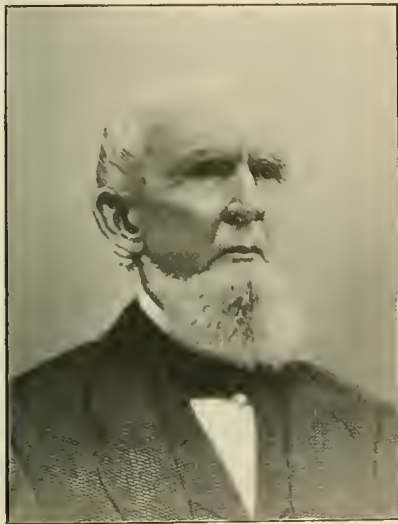

WILLIAM SWINBURNE.



WILLIAM S. HUDSON.



JOHN COOKE.

done, but Mr. Baldwin, who was then opposed to multi-coupled engines would not bid on building it. Norris was next tried, and he was willing to build the engine and named a price, but the engineering department of the Erie were opposed to heavier engines at that time, so nothing was done about it. Brandt afterward sent the drawings to James Millholland, who built an engine according to the drawings, and it was the first ten-wheel engine on the Philadelphia & Reading Railroad, antedating the patented ten-wheel engine of Septimus Norris by several years.

Brandt left the Erie and begun building locomotives in Paterson, N. J., remaining in the business several years, building locomotives, which had a high reputation. He was of Pennsylvania German stock, with strong home affinities, and never settled away from his native town, Lancaster, Pa. After being in Paterson a few years he tired of

nearly uniform as possible in details had not then become popular, for according to a report made in 1870, the company had 85 different patterns of locomotives. The builders were numerous and, of course, they were all striving to surpass each other in the building of engines that would secure popularity and thereby increase the business of the makers. There was long a belief prevalent among railroad men that certain makes of locomotives were per se better than other makes, and that they could do more work without exact regard to the dimensions. Latter day engineering has demonstrated that one make of engine must exert as much tractive power as another when the dimensions and steam pressure are equal; but very different opinions held sway among pioneer railroad men, and it has not entirely disappeared to-day. There were differences of details that made and held the

gives such a good idea of the gradual growth of the locomotive, that I think it will make interesting reading to people connected with railroads. Particulars of the first Norris engines have been given. The descriptive article referred to says:

Engines 4 and 5, by Norris, have 10 3/4 cylinders, 18 in. stroke, four drivers 4 ft. 7 in. diameter and 4 ft. trucks; 343 sq. ft. tube surface, 33 of firebox surface and 7 1/2 ft. of grate. Weight, 30,700 lbs., of which 21,100 lbs. are on the drivers. Steam used at one revolution, 3,782 cu. ft.

No. 6, by Rogers, Ketcham and Grosvenor, weighs 40,625 lbs., on drivers 24,250 lbs. No. 7, by same builders, Fig. 54, weighs 48,200 lbs., of which 31,300 are on drivers; cylinders outside, 15 1/2 x 22 in.; 5 ft. drivers and truck.

No. 9, Baldwin, has outside connected cylinders 15 in. diameter, stroke 18 in. Six drivers 46 in. diameter, no

truck; 860 sq. ft. tube surface to $42\frac{1}{2}$ firebox; 8 sq. ft. of grate and weight on all drivers 44,200.

No. 10, by Norris, outside cylinders $12\frac{3}{8}$ in. by 26 in.; 4 drivers = ft. diameter on truck; heating surface, 708 sq. ft. in tubes; 54 in firebox and 10 sq. ft. grate area; weight, 43,920, of which 26,880 are on drivers.

Nos. 11, 13, and 17, by Swinburne, Smith & Co., have the half crank, cylinders 17 in. by 20 in. stroke; have four 4.6 ft. drivers and truck; $943\frac{1}{2}$ sq. ft. tube, $68\frac{1}{2}$ sq. ft. firebox, and $12\frac{7}{8}$ sq. ft. of grate surface.

Nos. 14, 15, 16, 36 to 39 inclusive, and 46 and 47 by the same builders, same as above, only 5 ft. drivers, $59\frac{1}{2}$ sq. ft. of firebox surface and $12\frac{1}{8}$ sq. ft. of grate; weight, 59,900 lbs., of which 27,900 lbs. are on drivers. Steam used at one revolution, 10,508 cu. ft.

No. 12, by Rogers, Ketcham & Grosvenor, Fig. 55; half crank, 17 in. cylinders, 20 in. stroke, six 5 ft. drivers and truck, 1,080 sq. ft. tube, 67 sq. ft. fire box and 15 sq. ft. of grate surface; weight, 58,000 lbs., of which 42,300 lbs. are on drivers. Steam used at one revolution 10,508 cu. ft.

Nos. 18, 19, 28, 29 and 32, by Rogers, Ketcham & Grosvenor; half crank, 17 in. cylinder, 20 in. stroke; four 6 ft. drivers and truck; $922\frac{1}{2}$ sq. ft. tube, $67\frac{1}{2}$ sq. ft. fire box and 13 sq. ft. of grate surface. Weight, 56,500 lbs., of which 35,750 are on drivers. Consumption of steam, same as No. 12.

Nos. 30 and 31, by same builders, have 5 ft. drivers and $61\frac{1}{2}$ sq. ft. of furnace surface. Weight, 54,500 lbs., of which 33,500 lbs. are on drivers.

Nos. 20, 21, 23 and 27, by M. W. Baldwin, same as 18 and 19, except 938 sq. ft. tube, $65\frac{3}{4}$ sq. ft. fire box and $12\frac{7}{8}$ sq. ft. grate. Weight, 56,500 lbs., of which 34,800 are on drivers. Nos. 22, 24, 25 and 26, by same builder, same as 20, except 5 ft. wheel and 60 sq. ft. fire box surface. Weight, 54,500 lbs., of which 32,600 are on drivers.

Nos. 33, 34 and 35, first class freight engines, by Rogers, Ketcham & Grosvenor. These have half cranks, 18 in. cylinders, 20 in. stroke; six 5 ft. drivers and truck. Boilers 48 in. diameter, containing 198 tubes $13\frac{3}{4}$ in. diameters and 13 ft. long; 1,179 sq. ft. of tube, 72 sq. ft. of fire box and $14\frac{2}{3}$ sq. ft. of grate surface. Weight, 65,000 lbs., of which 49,000 lbs. are on drivers; the amount of steam expended at one revolution 11,788 cu. ft.

Nos. 40 to 45, inclusive, by Rogers, Ketcham and Grosvenor, have nearly the same dimensions and weight as Nos. 30 and 31, by the same builders. The general dimensions are identical. The weight may be given as 28 tons, of which 16 tons are on the drivers.

No. 48, by Swinburne, Smith & Co., has half crank, 16x20 cylinders, four 5 ft. drivers and truck. Boiler has $784\frac{1}{2}$ sq. ft. tube, $60\frac{1}{4}$ fire box and 13 of grate surface. Weight, 50,700 lbs., of which 32,100 are on the drivers. Steam used at one revolution, 9,308 cu. ft.

Nos. 49, 50 and 51, and Nos. 67, 68 and 69, by Swinburne, Smith & Co., have half cranks, 17 in. cylinders, 20 in. stroke, six 5 ft. drivers and truck. Heating surface, $1,025\frac{1}{4}$ sq. ft. tube, $61\frac{1}{2}$ sq. ft. fire box and $13\frac{1}{2}$ sq. ft. grate surface. Weight averages 62,500, of which 45,500 are on drivers. Steam used at one revolution, 10,508 cu. ft.

Nos. 52, 53 and 54, built by the Western Locomotive Works, have inside connected cylinders 15 in. in diameter, 20 in. stroke; four 5 ft. drivers and truck; 711 sq. ft. tube surface, $59\frac{1}{2}$ sq. ft. fire box and 10 sq. ft. grate surface. Weight 47,920 lbs., of which 30,050 are on drivers. Steam used at one revolution 8,181 cu. ft.

Nos. 57 and 58, Fig. 56, are first class engines, by M. W. Baldwin; they are used as pushers on 68 ft. grades. They have $18\frac{1}{4}$ in. cylinders, 23 in. stroke, 8 connected drivers of 4 ft. diameter and contain 147 tubes 2 in. diameter and 14 ft. long; 1,077 sq. ft. of tubes, $67\frac{1}{2}$ sq. ft. of fire box and 14 of grate surface, and 4 forward drivers, which combined in truck although it would seem that the coupling rods would prevent any sensible vibration. The whole weight of these engines is 73,700 lbs. of which 45,700 lbs. are on the four forward drivers alone giving 11,425 lbs., or nearly $5\frac{3}{4}$ tons on a single wheel. Steam used at one revolution, 13,927 cu. ft.

Nos. 61, 62 and 63, by Taunton Locomotive Manfg. Co., these are inside connections, with 17x20 in. cylinders, four 5 ft. drivers and truck.

Nos. 64 and 65 are extreme outside connections built by Rogers, Ketcham & Grosvenor. They have 17x30 in. cylinders, four 5-foot drivers and a truck; 795 sq. ft. of tube surface, $57\frac{2}{3}$ fire box, $13\frac{1}{4}$ grate. Weight, 55,600 pounds, of which 35,600 pounds are on the drivers. Steam at one revolution, 10,508 cu. ft.

No. 66, inside connected, by Rogers, Ketcham & Grosvenor, 17x20 in. cylinders, four 6-foot drivers and truck, $872\frac{3}{4}$ sq. ft. tube surface, $75\frac{1}{2}$ fire box, 14 sq. ft. of grate surface. Weight, $28\frac{1}{4}$ tons.

Nos. 70 and 71, inside connections, by Swinburne, Smith & Co. Cylinders 17x20 ins., four 6-foot drivers, $948\frac{1}{2}$ sq. ft. tube surface, $71\frac{1}{4}$ fire box, $13\frac{1}{2}$ sq. ft. grate. Weight, 53,000, of which 33,900 pounds are on the drivers. Steam used at one revolution, 10,508 cu. ft.

Nos. 72 to 83, inclusive, inside connections, freight engines, by Swinburne, Smith & Co. Cylinders 17x20 ins., six drivers, four wheel truck. boilers 46 in.

diameter, containing 157 2-in. tubes, 13 feet long; heating surface $1,068\frac{3}{4}$ sq. ft. in tubes, $69\frac{1}{4}$ in. fire box; $13\frac{1}{2}$ sq. ft. grate area.

Nos. 84 and 85, outside connected, are Norris eight-wheel connected engines. Cylinders 14x32 in., drivers $708\frac{1}{2}$ sq. ft. tube surface, $54\frac{1}{2}$ fire box, $11\frac{1}{2}$ sq. ft. grate area. Weight, 57,450 pounds, of which 38,950 pounds are on drivers. Steam used at one revolution, 11,403 cu. ft.

No. 86, half crank engine, built by Rogers, Ketcham & Grosvenor. Cylinders 17x20, 6-foot drivers and truck; $923\frac{1}{3}$ sq. ft. tube surface, $67\frac{1}{2}$ fire box, $13\frac{1}{2}$ grate area. Weight, 65,175 lbs., of which 47,000 are on drivers. Steam used at one revolution, 10,508 cu. ft.

Nos. 87 and 112, inside connected, Boston Locomotive Works (Hinkley). Cylinders 15x20 in., one pair of drivers $5\frac{1}{2}$ ft. diameter and one pair of trailing wheels and four wheel truck. Heating surface in tubes 616 sq. ft., fire box 66 sq. ft., $11\frac{2}{3}$ grate area. Steam used at one revolution, 8,181 cu. ft.

Nos. 88 and 89, outside connected, by Ross Winans. Cylinders 19x22 in., eight wheel connected; $918\frac{1}{4}$ sq. ft. tube surface, $85\frac{1}{2}$ fire box and $20\frac{1}{4}$ grate surface. Weight, 56,000 lbs. Steam used at one revolution, 14,439 cu. ft.

Nos. 90 to 99, inclusive, inside connected, by Boston Locomotive Works. Cylinders 16x20, four $5\frac{1}{2}$ -foot drivers and truck. Heating surface of tubes $719\frac{3}{4}$ sq. ft., of fire box $62\frac{2}{3}$ sq. ft., of grate surface 10 sq. ft. Weight, 49,510 lbs., of which 30,840 lbs. are on drivers. Steam used at one revolution, 9,308 cu. ft.

Nos. 100 to 105, inclusive, inside connected, by Rogers, Ketcham & Grosvenor. Cylinders 17x20 in., four 6-foot drivers and four wheel truck. Heating surface of tubes $772\frac{1}{4}$ sq. ft., $80\frac{2}{3}$ sq. ft. fire box, $15\frac{1}{2}$ grate surface. Weight, average 57,500 lbs., of which 37,400 lbs. are on drivers. Steam used at one revolution, 10,508.

Nos. 113 and 114, Taunton engines, inside connected. Cylinders 17x20 in., four driving wheels 5 ft. in diameter and four wheel truck. Heating surface of tubes 939 sq. ft., 90 sq. ft. in fire box, $16\frac{1}{8}$ grate area.

Nos. 115 to 118, inclusive, are by Taunton Locomotive Company. Cylinders 18x20 in., four driving wheels 5 ft. in diameter and four wheel truck. Heating surface in tubes $857\frac{1}{4}$ sq. ft., 90 sq. ft. in fire box, $16\frac{1}{8}$ sq. ft. grate area. Steam used at one revolution, 11,781 cu. ft.

Nos. 119 to 124, inclusive, outside connected by Boston Locomotive Works. Cylinders 16x26 in., four drivers 5 ft. diameter and four wheel truck. Heating surface of tubes 792 sq. ft., $83\frac{1}{2}$ sq. ft. in fire box and $15\frac{3}{4}$ grate area. Weight,

52,675 lbs., of which 31,000 lbs. are on drivers. Steam used at one revolution, 12,101 cu. ft.

Nos. 125 and 126, by Amoskeag Manufacturing Company, inside connected. Cylinders 18x20 in., six driving wheels 4½ ft. diameter, no truck. Heating surface of tubes 803½ sq. ft., 743½ fire box, 15 grate area.

Nos. 127 and 132, inclusive, Boston Locomotive Works. Cylinders 17x20, four drivers 5½ ft. diameter, four wheel truck. Weight, 54,400 lbs., of which 34,950 are on drivers. Steam used at one revolution, 10,508 cu. ft.

Nos. 133 to 135, outside connected, by New Jersey Locomotive & Machine Company. Cylinders 16x20 in., four 5-foot drivers and truck. Heating surface of tubes 670¼ sq. ft., fire box 54¼, grate area 12¾. Steam used at one revolution, 9,308 cu. ft.

Nos. 136, 137, 138 and 141 same as No. 72, by Swinburne, Smith & Company.

Nos. 139 and 140, about the same as

tive power of the Erie is considerable heavier than any of the others, even when the others have very heavy grades to operate.

The first Hinkley locomotive was brought to the road by Horatio G. Brooks, who soon established a reputation for himself and for the engine by taking his trains through on time, a decided departure from the prevailing practice. Mr. Brooks, after a few years experience as engineer on the Erie, was appointed master mechanic of the Ohio & Mississippi. Two years later he was called back to the Erie as master mechanic, a move which eventually enabled him to establish the Brooks Locomotive Works.

A Consolidation for the Chicago, Milwaukee & St. Paul Railway.

The Baldwin Locomotive Works have recently supplied the Chicago, Milwaukee & St. Paul Railway, of which Mr. A. E. Manchester is super-

hung springs and the rear two pair have driving box equalizers and springs between top and bottom frame bars. The main drivers are the third pair and the eccentrics are placed on this axle. As the radius of the links is 47½ ins. and the wheels are spaced with tires about 6 ins. apart, there is a transmission bar used, which runs back from the link block to the lower end of the rocker arm. The valves are of the D-slide type and are driven by indirect motion. The steam ports are 1¾ ins. and the throw of the eccentrics is 5 ins.

The boiler measures 72 ins. outside diameter at the front end and contains a total heating surface of 2608.65 sq. ft. made up of 2423.03 in the flues and 185.62 in the fire box. The flues are 321 in number and are 14 ft. 6 ins. long. The boiler is of the straight top variety and the fire box is what may be called medium wide, as it extends over and above the frame. The grate area



CHICAGO, MILWAUKEE & ST. PAUL, 2-8-0 ENGINE.

A. E. Manchester, S. M. P.

Baldwin Locomotive Works, Builders.

above, except 1,072½ sq. ft. tube surface, 82½ fire box and 16½ grate area.

Nos. 142 and 143, inside connected, by Essex Company. Cylinders 17x20 in., four driving wheels 4½ ft. diameter and four wheel truck. Boiler 49 in. in diameter, containing 190 17½-in. tubes, 11 ft. long, 1,0257½ sq. ft. tubes, 76¾ fire box and 16 ft. grate surface. Weight, 58,250 lbs., of which 36,450 lbs. are on drivers. Steam used at one revolution, 10,508 cu. ft.

The article goes on to say that the Erie Railroad Company has contracted for the construction of 28 heavy engines having cylinders 18x20 in. stroke. A few particulars are given concerning the motive power of other leading railroads showing the tendency toward heavier engines than what had previously been used. A comparison is made with the motive power of the Baltimore & Ohio and with the Philadelphia & Reading, and a statement is made that the mo-

intendent of motive power, with some consolidation on 2-8-0 type of engine. The cylinders are 22x28 and the diameter of the driving wheels is 56 ins. With 200 lbs. boiler pressure and the mean effective pressure in the cylinders assumed to be 85 per cent., the boiler pressure—which is according to the Master Mechanics' Association formula—the tractive effort of the engine, is about 41,100 lbs. and the ratio of tractive effort to adhesive weight is as 1 is to 3.8.

The weight on the drivers is 156,400 lbs. while that carried on the truck is 20,600 lbs. The weight of the whole engine is 177,000 lbs., and as the tender weighs 125,600 lbs., it gives a total of 302,600 lbs. for engine and tender. The engine is equalized in the usual way, with pony truck and forward driver together and the main, rear and intermediate drivers equalized together. The first two pair of drivers have over-

is 47.45 ft. There are three blow off cocks, one in the center of the throat sheet close to the mud ring and one on each of the fire box side sheets, low down, about over the space between the main and rear drivers.

A few of the principal dimensions are as follows:

Cylinder—22x28.

Boiler—Dia., 72 ins.; thickness of sheets, ¾ in.; working pressure, 200 lbs.; staying, radial.

Fire box—Length, 101¾ ins.; width, 65¾ ins.; depth, front, 60½ ins.; back, 55½ ins.; thickness of sheets, sides, ¾ in.; back, ¾ in.; crown, ¾ in.; tube, ½ in.; water space, front, 4 ins.; sides, 4 ins.; back, 3 ins.

Tubes—Material, iron; wire gauge 11 ins.

Driving Journals—Main, 9x12 ins.

Engine truck wheels (front), dia. 30 ins.; journals 6x10 ins.

Wheel base—Driving 15 ft. 3 ins.; total engine, 23 ft. 11 ins.

Weight—On driving wheels, 154,270 lbs.; on truck, front, 20,400 lbs.; total engine, 174,670 lbs.; total engine and tender, 300,000 lbs.

Tank—Capacity, 7,000 gals.

Tender—Wheels, dia., 33 ins.; journals, 5x0.

If President W. H. Truesdale of the Delaware, Lackawanna & Western Railroad Company should place his road's rolling stock on parade it would make a train 300 miles long, or long enough to reach from Dewitt to New York by way of the Central. This is based on the measurement of the average length of the 700 locomotives and 27,000 cars of all descriptions in the Lackawanna's stock. With the foreign cars every day on the Lackawanna a train could easily be made any day which would reach from Buffalo to New York by way of the Lackawanna.

Pressed Steel Cars.

This is the exhibit of the Pressed Steel Car Company, of Pittsburgh, Pa., at the Louisiana Purchase Exposition.

The first car in the train is the Pennsylvania Railroad Company's standard class "Gsa" type of pressed steel gondola; it is 40 ft. in length and has wooden drop ends for use in twin and triplet

the pressure on the chains and acting as a support to the load held by the doors. On the other side of the car the controlling rod is fixed, that is, it merely opens or closes the doors by revolving without acting as a support to them. The rods in either case are operated by means of a worm gear worked by a wheel similar to the ordinary brake wheel, one at each corner at the ends of the car. The car is fitted with pressed steel diamond trucks, pressed steel bolsters, Westinghouse air brakes, McCord journal boxes, Miner draft rigging, pressed steel brake beams and the Lindstrom hand brake, the same as is used on Pullman passenger coaches. This latter is the invention of Chief Engineer Lindstrom, of the Pressed Steel Car Company. The car weighs 41,500 lbs., and is 100,000 lbs. capacity.

The third car is a box car of new design with structural steel underframing and steel superstructure. To show a portion of the steel superstructure part of the wooden sides and lining on one

In addition to the equipment mentioned, the Pressed Steel Car Company are exhibiting their pressed steel mine dump car, which is a new departure in steel construction; their pressed steel Fox tender truck frame, pressed steel body and truck bolsters, pressed steel brake beam, pressed steel side stakes and center plates, together with a number of their model appliances for use in freight car construction.

Now, and Then.

One modern iron and steel plant at Hamilton, Ont., Canada, bases a claim to distinction on the fact that it bought and reworked the iron of the steamship *Great Eastern*, which in its day was the largest ship in the world; the material of the original Niagara Suspension Bridge, which for many years was the only span crossing the Niagara river; the iron of the Victoria Tubular Bridge, at Montreal, which in its day was one of the wonders of the world, and that



PRESSED STEEL CAR COMPANY'S EXHIBIT AT THE LOUISIANA PURCHASE EXPOSITION.

loads; drop doors; weight 39,400 lbs. This car is equipped with P. R. R. standard arch bar trucks, Westinghouse air brakes, and Westinghouse friction draft rigging, National hollow brake beams. Pressed steel bolsters and Melrose cast steel couplers furnished by the Latrobe Steel & Coupler Co. The car has a capacity of 100,000 lbs.

The second car is a pressed steel side dump gondola car, but built on an entirely new design. This car is 41 ft. 6 ins. in length, and the whole bottom of the car consists of drop doors fastened throughout the length of the car at the center and so arranged that the whole load can be dumped at either side of the track, while the doors when closed give the car an entirely flat bottom for shoveling out. This car is intended specially for carrying ballast, gravel, sand, dirt and similar freight that is dumped. There are two kinds of doors on it to demonstrate both arrangements; on one side the doors are controlled by a sliding shaft consisting of a rod running lengthwise of the car at the outside of the doors, the chains for raising the doors being fastened to it. To open or close the doors the rod is turned so that they can be made to let out the contents of the car rapidly or slowly. At the same time the rods can be slid in position under the edge of the doors, thus relieving

side of the car has been removed. The dimensions of the car are the same as those laid down by the American Railway Association for a regular 36 ft. box car. The total weight of the car is 40,000 pounds, which is from two to three thousand pounds lighter than a similar wooden car with pressed steel underframing. The same ideas that obtain in the construction of a steel framed building apply to this car, part of the weight of the load being borne by the sides of the structure. This helps to make the car lighter by reason of not so heavy material being used in the underframing. The car is equipped with Pressed Steel Car Company's Fox pressed steel trucks, Westinghouse air brakes, twin spring draft rigging, No. 2 Security side doors, furnished by the Camel Company, Chicago; Chicago-Cleveland Company's Winslow roofing, Camel Company's adjustable journal bearings with wedges complete, Hartman drop forged ball bearing center plates, malleable iron side bearings, pressed steel bolsters and pressed steel brake beams. This car has pressed steel carlines and the posts and braces are made of rolled angles.

The fourth car is an improved steel flat car with wooden floor, 33,100 lbs. weight—much lighter than the average car with a similar capacity.

of the once famous and record breaking Atlantic liner *City of Rome*. This old material was worked over into bar iron and was largely consumed in the construction of agricultural implements.

Verily, the fashion of this world passeth away. For many of us these great achievements of engineering skill are remembered as contemporaneous events, which seemed to mark the limitations of human effort in their several directions. As compared with the commonplaces of to-day they are scarcely of historical interest.—*New York Times*.

A High Speed Motor Driven Pump.

The operation of pumping machinery by electric motors offers, especially in mines, many obvious advantages, such as the centralization of the power plant, elasticity of extension of the system, high efficiency and small first cost and small expense for attendance.

This pump has the many objectionable features usually found in pumps, such as toothed gearings, belts, etc., eliminated by connecting the pump plungers to cranks mounted directly upon the shaft of the motor. This pump has a capacity of about 250 gallons per minute against 1,000 ft. head when running at a speed of about 300 revolutions. The plungers are 3½ ins. in diameter and have a stroke

of 5½ ins. In a very carefully conducted test, the diagram pump proved to be a great success. The volume of water pumped was measured by means of a carefully constructed and calibrated Freeman nozzle and all gauges were tested before and after the test by means of a weight gauge tester. The pressure at the nozzle was measured by a mercury column connected to a piezometer chamber.

The pump and motor are mounted upon a rigid box girder frame and the unit is self contained and occupies a relatively small space. It contains many novel features of construction and the most careful attention has been given to the design of the internal parts, as well as to the running parts and oiling devices.

This type of pump, which has only lately been introduced, has advantages never before attained. The pumps are built by the Blake & Knowles Steam Pump Works, of 114 Liberty street, New

The boiler is of the straight top variety with medium-wide fire box, level crown sheet and level roof sheet. The space between these sheets is about 22 ins. The boiler is 78 ins. in diameter at the smoke box end. The heating surface in the tubes amounts to 3,512.2 sq. ft., the fire box gives 190.5 sq. ft., and the water tubes, 26.8 sq. ft. The total is 3,729.5 sq. ft. The tubes are 450 in number and are 15 ft. long.

The tender is mounted on a 12 in. steel channel frame. The tank has a water bottom and will hold in all 8,000 U. S. gallons. The fuel space is partly arched over and the slope of the sheets is such as to force the coal to work down to the tank deck as used. A few of the principal dimensions are appended for reference.

General Dimensions—Weight in working order, 201,000 lbs.; weight on drivers, 178,000 lbs.; weight engine and tender in working order, 346,630 lbs.; wheel base, driving, 15 ft. 8 ins.;

It Looks as if Railroad Shopmen Are Pretty Safe.

The French journals have recently given publicity to a scientific discovery which may have a considerable influence upon one of the most ordinary usages of social intercourse. One M. Crouzel, a chemist at Bordeaux, has discovered that the human hand is largely occupied in sowing the seeds of all sorts of diseases. The hand, he says, is not only the most dirty, but the most dangerous portion of our anatomy. It contains on the average 83,450,000 bacilli. Hence, he argues, people should never shake hands. We know already that it is dangerous to kiss; but now, as a French paper puts it, science is no less hostile to friendship than to love. All men, however, are not equal in this matter. You must not shake hands with a physician, surgeon, hairdresser or butcher—especially a pork butcher. Workers in metal are, however, much



A HEAVY CONSOLIDATION FOR THE Q.

York City, in capacities of from 200 to 4,000 gallons per minute and for heads varying from 100 to 2,000 feet. One of these pumps operated by a direct current motor is being exhibited in the space of the General Electric Company at the St. Louis Exposition.

Heavy Consolidation for the "Q."

The American Locomotive Company have recently supplied the Chicago, Burlington & Quincy Railroad through Mr. F. H. Clark, superintendent of motive power, with some heavy 2-8-0 engines for freight traffic.

The engines have been built at the Schenectady works and are simple, with piston valves. The cylinders are 22x28 ins. and the driving wheels are 57 ins. in diameter. The engine weighs 201,000 lbs. in working order. The boiler pressure is 210 lbs. and this gives a calculated tractive effort of about 42,400 lbs. The valve motion of this engine is direct with transmission bar passing over the axle of the second pair of drivers, both arms of the rocker hanging down from the pivot.

wheel base, total, 24 ft. 4 ins.; wheel base, total, engine and tender, 58 ft. 5¾ ins.

Valves—Greatest travel of slide valves, 6 ins.; outside lap of slide valves, 1 in.; inside clearance of slide valves, ¼ in.; lead of valves in full gear, line and line at front with ¼ in. lead at ¼ cut-off.

Wheels, etc.—Diam. and length of driving journals, 9 ins. and 9½ ins. in diam. x 12 ins.; engine truck, journals, 6 ins diam. x 10 ins.

Boiler—Outside diam. of first ring, 78 ins.; working pressure, 210 lbs.; thickness of plates in barrel and outside of fire box, ¼ in., ⅞ in., 1 in., ¾ in., ⅝ in.; fire box, length, 108 ins.; fire box, width, 72¼ ins.; fire box, depth, front, 79½ ins.; back, 68½ ins.; fire box, plates, thickness, sides, ⅜ in.; back, ⅜ in.; crown, ⅜ in.; tube sheet, ⅜ in.; fire box, water space, 4½ ins. front; 4½ ins. sides; 4½ ins. back; fire box, crown staying, radial, 1½ ins.; tubes, material and gauge, charcoal iron, No. 1 B. W. G.; number, 450; diam., 2 ins.; tubes, length over tube sheets, 15 ft. 0 in.; fire brick, supported on water tubes; heating surface, tubes, 3,512.2 sq. ft.; heating surface, water tubes, 26.8 sq. ft.; heating surface, fire box, 190.5 sq. ft.; heating surface, total, 3,729.5 sq. ft.; grate surface, 54.2 sq. ft.; smoke stack, inside diam., 16 ins.; smoke stack, top above rail, 15 ft.

Tender—Weight, empty, 54,680 lbs.; journals, diam. and length, 5 ins. diam x 9 ins.; wheel base, 20 ft. 6 ins.; tender frame, 12 ins. steel channels; water capacity, 8,000 U. S. gallons; coal capacity, 12 tons.

less dangerous, because the minute metallic particles form, under the influence of the hand's warmth, an antiseptic oxide. It is possible, M. Crouzel says, to protect yourself, if you must shake hands, by using soap and a nail brush for five minutes, plunging your hand in a warm alkaline solution, rinsing it with sterilized water, drying it on a sterilized rough towel, and finally washing it again in a solution of alcohol and ether. We commend this precaution to public men in general, and to the President of the United States in particular. —London Graphic.

The Sturtevant Improved Hand Blowers.

In these modern times men are always seeking devices by which they may accomplish the greatest results with the least exertion. To this fact, doubtless more than any other, was due the rapid introduction of the hand blower as a substitute for the old time bellows. During the years which have elapsed since this change the B. F. Sturtevant Company, of Boston, Mass., pioneers in the

manufacture of blowers, have been perfecting their design and construction until their hand blower, known as style A, has shaped itself into a new design known as style B, as herewith illustrated.

These hand blowers have been extensively introduced in connection with new forges of all kinds and have likewise been applied to old style brick and iron forges as simple, efficient and economical substitutes for the bellows. Not only are they adapted to forge blowing but can readily be applied as portable ventilating apparatus. They are simple in design, strong, rigid and compact, easy and economical in operation and readily portable. The running gear is simple, effective and strong.

The blower is adjustable on the shaft and its outlet may thus be set to discharge in any direction and readily con-

proportionately greater capacity for delivering air. The driving wheel is 24 ins. in diameter, the blower outlet is $4\frac{3}{4}$ ins. in diameter and the complete outfit weighs 155 pounds.

Star Improved Indicator.

The Star Brass Manufacturing Company, of Boston, Mass., have got out an improved form of indicator in which the spring is placed outside of the little steam cylinder, the drum and pencil motion remaining the same as in the former types made by this concern. The area of the piston has been reduced to equal one-quarter of a square inch, for the purpose of allowing much smaller wire to be used in the spring, and this gives greater elasticity and freedom in operation.

Another feature is that the pressure of the steam pulls the spring apart, and this,

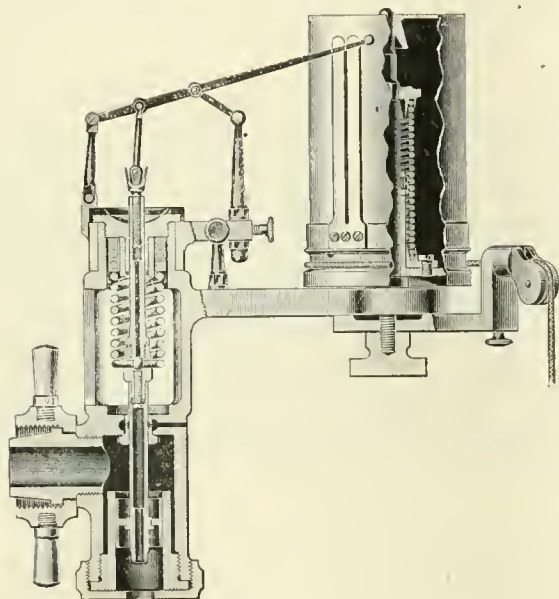

STAR IMPROVED INDICATOR.

nected to the forge tuyere by means of galvanized iron piping. The blower is of cast iron, strongly constructed in every particular, has a steel shaft running in babbitted boxes and a fan wheel of galvanized steel solidly riveted to a composition hub with extending arms.

The frame is carefully designed, well braced and is so arranged that the slackness of the belt driving the blower may be taken up by lowering the blower shaft, which is supported by collars sliding on the frame. The feet are provided with holes so that the hand blower may be readily screwed to the floor. These hand blowers are made in two sizes. The total length on the floor of style B-1 is 18 ins., while the total height of the frame, not including the handle, is 48 ins. The driving wheel is 24 ins. in diameter, the blower outlet is $3\frac{1}{2}$ ins. in diameter and the complete outfit weighs but 135 pounds. Style B-2 is of slightly larger dimensions and has

it is claimed, tends to move everything in a straight line. This makes the atmospheric line come at the top of the card when it is on the drum. The cylinder can readily be removed for examination by unscrewing the cap at the bottom. The steam cylinder is always surrounded by live steam when in use. The connection to this indicator is made at the side and the steam pressure is, therefore, exerted on the top side of the indicator piston.

The Westinghouse Companies at the Louisiana Purchase Exposition.

The Westinghouse interests represented at the St. Louis Exposition number 21 companies which represent an army of 30,000 employees and occupy a total workshop floor space of over 140 acres.

The principal exhibit is that of the Westinghouse, Church, Kerr & Co., and it is the main service plant which

supplies power for the Fair. The entrance to this plant is had through a large 35 ft. plaster ring which is a duplicate of the stationary armature of the 5,000 K.W. alternating current generators made for the elevated and subway train service in New York. The electrical units at St. Louis are almost three times as large as those used at the Chicago exhibition; they are direct driven and the total floor space used is 26,260 sq. ft. The steam generating plant was furnished by the Westinghouse Machine Co. Altogether it forms an exhibit plant representative of thoroughly modern practice at minimum cost.

In Machinery Hall, in addition to the electric service plant and the main exhibit of Westinghouse gas engines, turbo-generators, rotaries, exciters, and motors in operation, all enclosed within ornamental staff walls, is the Westinghouse auditorium which holds 350 persons, in which at stated times moving pictures of scenes in and about the Westinghouse works in the Pittsburgh districts. The photographs of interiors were taken by aid of the Cooper-Hewitt mercury vapor lamp. The hall is lighted by the Sawyer-Mann incandescent lamps, Brewer arc lamps, the Cooper-Hewitt lamp and the Nernst glowers, all products of the Westinghouse companies. The auditorium is used for the meetings of scientific and technical societies.

The Westinghouse Air Brake exhibit is a rack made up of the equipment of a six coach train with engine and tender, high speed brake and signal equipment. The engine and tender having the combination of automatic and straight air. The method adopted when two pumps are used on one engine, is shown. The valves have a sectional duplicate working with them, so that the movement of parts can be studied. Westinghouse friction draw gear is shown in section along with a machine for testing its action.

The Union Switch and Signal Company's exhibit is a group of full size working signals. A full size model of the Pennsylvania tunnel under the Hudson with tunnel signal, is exhibited. The company's most important exhibit is really the Westinghouse electro-pneumatic interlocking system installed in the Union station yard at St. Louis.

The first lesson of scientific education should be that a man's brain cells are not only money but capital, and that it is just as possible to dissipate them foolishly as to use them in the work of building up a career.

The things that never happen are often as much realities to us in their effects as those that are accomplished.

Of Personal Interest.

Mr. D. Cunningham has been appointed roundhouse foreman on the Norfolk & Western Railway at Portsmouth, Ohio.

Mr. John Crouch has been appointed roundhouse foreman on the Pennsylvania Railroad at Conemaugh, Pa., vice Mr. J. C. Crookston, assigned to other duties.

Mr. John Clay, formerly of Dunmore, Pa., has been appointed roundhouse foreman at Port Jervis, N. Y., on the Erie Railroad, vice Mr. A. Moriarty, promoted.

Mr. Thomas Coyle has been promoted from the position of roundhouse foreman at Perth Amboy, N. J., to that of master mechanic on the Lehigh Valley Railroad, with office at Weatherly, Pa.

Mr. J. J. Thomas, Jr., has been appointed master mechanic on the Atlantic Coast Line, with office at South Rocky Mount, N. C., vice Mr. J. W. Oplinger, promoted.

Mr. H. L. Fry has been promoted to the position of engineer of maintenance of way on the Southern Railway, with office at Greensboro, N. C., vice R. Southgate, deceased.

Mr. H. M. Meason, formerly roundhouse foreman on the Pennsylvania at Piteairn, Pa., has been appointed assistant master mechanic Pittsburg division, vice Mr. J. E. Mechling, promoted.

Mr. T. S. Davey has been appointed general foreman of the New York, Susquehanna & Western Railroad shops at Stroudsburg, Pa., vice Mr. M. N. Diefenderfer, transferred to Dunmore, Pa.

Prof. W. F. M. Goss, dean of the Schools of Engineering, of Perdue University, recently received the honorary degree of Doctor of Engineering (D. Eng.), which was bestowed upon him by the University of Illinois.

Mr. S. L. Bean, formerly master mechanic at Albuquerque, N. M., has been appointed mechanical superintendent of the Atchison, Topeka & Santa Fe Coast Lines, with headquarters at Los Angeles, Cal., vice Mr. G. R. Joughins, resigned.

Mr. J. E. Mechling, formerly assistant and master mechanic, on the Pittsburgh division of the Pennsylvania Railroad, at Piteairn, Pa., has been promoted to be master mechanic on the Vandalia Line, with headquarters at Terre Haute, Ind.

Mr. A. Moriarty, formerly roundhouse foreman of the Erie Railroad at Port Jervis, N. Y., has been promoted to be the general foreman of the Bergen shops of the same company, vice Mr. O. F. Fixel, assigned to other duties at Meadville, Pa.

A great many railroad people will be highly pleased to learn that Mr. Albert J. Pitkin, formerly vice-president of the American Locomotive Company, has been elected to the office of president to succeed Mr. S. R. Callaway, deceased. Mr. Pitkin was born in Ohio fifty years ago, and passed through the machinist apprenticeship in a machine shop in Akron. It was probably his leaning towards locomotives that led Mr. Pitkin to choose a mechanical career, for he tells that when a boy the sight of trains passing his home inspired him with the ambition to be an engineer, which, like many other youthful fancies, faded with the growth of years. Its influence, however, may have guided to some extent his career, for on leaving his home shop he went to the Baldwin Locomotive Works, where he worked for several years, mostly in the drawing office. Then he became chief draughtsman of the



MR. ALBERT J. PITKIN,
President American Locomotive Co.

Rhode Island Locomotive Works which he left to become mechanical engineer of the Schenectady Locomotive Works, rising there to be general manager. Then when the American Locomotive Company was formed he was elected first vice-president. Mr. Pitkin has the capacity for working deeply into the affections of his associates. Dr. Williams, of the Baldwin Locomotive Works, used to talk with pathetic regret of the circumstances that took Mr. Pitkin away from his firm. In manner Mr. Pitkin is very cool and apparently subdued, but in fact he is an engine of energy. The writer once followed him for several weeks through Europe, and no matter what sleepless nights or laborious days had been passed, Mr. Pitkin was always ready for a new journey on a mo-

ment's notice. We anticipate that the American Locomotive Company will prosper in the control of such a president.

Mr. W. A. Nettleton, the well known railroad mechanical engineer, at one time assistant superintendent of motive power of the Atchison, Topeka & Santa Fe, and until recently engaged in private business, has been appointed general superintendent of motive power of the St. Louis & San Francisco System, with office in St. Louis, Mo.

Mr. M. N. Diefenderfer, heretofore general foreman of the New York, Susquehanna & Western shops at Stroudsburg, Pa., has been transferred to Dunmore, Pa., as general foreman of the Erie Railroad shops at that point. Before his departure from Stroudsburg his many friends presented him with a substantial token of their esteem and regard for him, and also entertained him at supper.

Mr. Warren S. Stone has been elected grand chief of the International Brotherhood of Locomotive Engineers at the Los Angeles convention. He has occupied that office by appointment since the death of A. B. Youngston following that of Grand Chief Arthur last August, and Mr. Stone has followed the conservative methods of Chief Arthur. Mr. Stone is popular among his colleagues. He is forty-four years old and has spent his entire railroad service on the Chicago, Rock Island & Pacific Railroad. His present home is in Cleveland, the headquarters of the Brotherhood.

Mr. H. F. Frevert for the past several years has been manager of the New York stores of the Niles-Bement-Pond Co., and the Pratt & Whitney Co., has severed his connection with these concerns and has opened an office at 114-118 Liberty street, for the sale of machinery. He is also manager of the New York office of The Norton Grinding Company, of Worcester, Mass., who are manufacturers of Emery grinding machinery. He is also manager of The Brightman Mfg. Co., of Shelby, Ohio, manufacturers of turned shafting, also machines for turning, rolling, straightening and polishing shafting.

Mr. David Van Alstyne has been appointed superintendent of motive power of the Northern Pacific Railroad with office in St. Paul, Minn., vice Mr. A. E. Mitchell, resigned. Mr. Van Alstyne, in his student days, was a graduate of the Massachusetts Institute of Technology. His early railroad work was done on the Louisville & Nashville, and he has been connected with the motive power department of the Chicago Great Western

Railway for a number of years. He has passed through the various upward steps on that road until he became superintendent of motive power some five years ago.

Mr. C. C. Tyler has resigned his position as superintendent of the works of the Westinghouse Electric & Manufacturing Company, at East Pittsburgh, Pa., and has been appointed general superintendent of all the works of the Allis-Chalmers-Bullock interests in the United States. Mr. Tyler will make his headquarters at Milwaukee. His record in the practical management of great machine shops is one of the best in the country. Before Mr. Tyler went to Pennsylvania he had made an excellent reputation, and at Pittsburgh, where has been for half a dozen years, he enhanced this by the results he achieved in increasing the efficiency of the Westinghouse electric works. In the equipment of manufactories, in the design and

N. H.; June 11, 1873, to November 1, 1892, general agent of the same road; November 1, 1892, to December 1, 1896, superintendent Worcester, Nashua and Portland division, Boston & Maine Railroad, at Nashua, where he was promoted to the position he has just vacated.

Mr. S. F. Prince, Jr., formerly superintendent of motive power of the Philadelphia & Reading, was, on the occasion of his leaving the road to accept service with the Niles-Bement-Pond Company, given a complimentary dinner at Reading, Pa., by the officers and men of the motive power department. Covers were laid for sixty-five and at the conclusion of a most enjoyable evening, Mr. Prince was presented with an elegant diamond stud and scarf pin combined. Appropriate speeches were made on the occasion and Mr. Prince replied in a suitable manner. The best wishes and most cordial feelings expressed by the representatives of the department over which he had presided follow him to his new field of work.

Mr. J. E. Sague, who was formerly assistant vice-president of the American Locomotive Company, has, at the last meeting of the board of directors, been elected vice-president of the company. Mr. Sague is a graduate of the Stevens Institute of Technology. His first active work was done in the office of the mechanical engineer of the West Shore Railway. The following year he entered the service of the Chicago, Burlington & Quincy as draughtsman. In 1886 Mr. Sague became engineer of tests for the Erie, and subsequently held the position of general foreman of the Jersey City shops, and later that of master mechanic at Rochester. He was from 1890 to 1892 superintendent of motive power of the Jamaica Railroad and mechanical engineer of the West India Improvement Company. In 1892 he became identified with the Schenectady Locomotive Works as mechanical engineer; in June, 1901, he came to New York as mechanical engineer of the American Locomotive Company and has been steadily advanced in the service of the great locomotive building concern.

Mr. Leigh Best has recently been elected third vice-president of the American Locomotive Company. He still retains his title as secretary to the company. Mr. Best began active work at the early age of twelve when he secured the position of office boy in the smelting works in his native village of Chatham. Subsequently, he was employed in a paper mill owned by his father where he worked in the finishing room. His next step was to enter the government service in the local post office. Later on, Mr. Best took a clerkship in a general store, and, while pursuing his labors there, he industriously burned the midnight oil, being anxious to secure the advantages of a college edu-

Working all day behind the counter and studying at night brought on an attack of nervous prostration within two weeks of the date of the examination which he hoped to undergo. At the age of nineteen, Mr. Best was employed as stenographer in the office of Messrs. Burrell & Co., manufacturers, at Little Falls, N. Y. While in this position his ambitions turned toward the study of law, and two years later we find him in the office of Messrs. Miller, Fincke and Brandigee, of Utica, N. Y. The training he received with this firm enabled him to take a position in the law department of the New York Central, which position he held from 1892 to 1900, and in this capacity he was brought into constant relations with the general counsel of the road to whom he became confidential assistant. In this way Mr. Best became known to the president of the road, the late Mr. Callaway, who recognized his ability and capacity for work; and in October, 1900, Mr.



MR. W. H. LEWIS,

Retiring President of the American Railway Master Mechanics' Association.

construction of machine tools, in the handling of machinery and material in processes of manufacture, and, in fact, in all that pertains to the economy of machine shop administration, Mr. Tyler is recognized as an expert. In entering upon his larger field of duty, he is sure to carry with him the congratulations of the engineering profession.

Mr. Frank Barr has been appointed third vice-president and general manager of the Boston & Maine Railroad. He occupies the position made vacant by the death of T. A. Mackinnon. Mr. Barr, who was made assistant general manager of the railway in question on December 1, 1896, entered the railway service on March 1, 1869, since which he has been consecutively to June 11, 1873, freight and ticket clerk and telegraph operator, Worcester & Nashua Railroad, at Nashua,



MR. PETER H. PECK,

New President of American Railway Master Mechanics' Association.

Best became assistant to the president of the New York Central. When the American Locomotive Co. was formed and Mr. Callaway became its chief executive officer, he took Mr. Best with him as secretary for the company and assistant to the president.

Mr. Webb C. Ball has been appointed time inspector of the Detroit & Mackinac Railway, with headquarters in Cleveland, Ohio. Mr. Ball holds a similar position on the Rutland Railroad and also on the Vanderbilt Lines, which latter include the New York Central & Hudson River Railroad, the Lake Shore & Michigan Southern, the New York, Chicago & St. Louis, the Michigan Central, the Delaware & Hudson, the Cleveland, Cincinnati, Chicago & St. Louis, the Chicago & Northwestern, the Chicago, St. Paul, Minneapolis & Omaha, and the Fremont, Elkhorn

& Mississippi Valley Railroads. Mr. Ball's latest appointment shows that the idea of standardization in watch inspection is certainly rapidly gaining ground.

Mr. John Henney, superintendent of motive power of the New York, New Haven & Hartford, has resigned.

Mr. Maurice Brown has been appointed traveling engineer on the Chicago Great Western, with headquarters at Dubuque, Ia., vice Mr. B. H. Everett, promoted.

Mr. F. B. Davant who has been instructor in the machine shops of the University of Tennessee at Knoxville has left to accept the position of general superintendent of the Glover Machine Works, Marietta, Ga. These works, which manufacture light locomotives, steam shovels, hoisting engines, etc., are extending their facilities.

Our friends who send in notices of change of address and of promotions often seem to forget one thing, and that is that there are over a thousand railroads in this country. Those who prepare the personal columns of our paper cannot tell by looking at a correspondent's name what road he is on unless the name of the road is stated. In sending in notices of promotions and appointments kindly look at those already in RAILWAY AND LOCOMOTIVE ENGINEERING and see that yours contains the necessary information.

RAILWAY AND LOCOMOTIVE ENGINEERING recently lost one of its best friends in the death of Arthur J. O'Hara, Port Jervis, N. Y., one of the old engineers of the Erie. Mr. O'Hara has been our agent at Port Jervis for many years, and was always an interested reader of the paper and did his best to induce others, especially young men, to enjoy the advantages that the paper conferred upon himself. His death was sudden and resulted from a shock sustained in jumping off his engine at the time of a collision.

When Scoville & Company tried to work up a business of locomotive building in Chicago in the early fifties their foreman was David R. Fraser, a young Scotchman, who had a little experience in a railway shop in Dundee. After the Scofield enterprise failed, Mr. Fraser kept working at his trade and after saving a little money turned his attention to the making of mining machinery. His work prospered and he organized the Fraser & Chalmers Company, which became one of the greatest engineering establishments in the world. David R. Fraser died last month at Chicago in the eightieth year of his age, ending a busy life that left useful marks which will endure for many years.

Mr. Edwin T. James, master mechanic of the Lehigh Valley, at Buffalo, has been promoted to shop superintendent, and will have charge of the extensive new shops

and plant that the company is completing at Sayre, Pa. He will report direct to Mr. A. E. Mitchell, superintendent of motive power. In the beginning, Mr. James is charged with the important task and responsibility of properly grouping and locating all the machinery to be installed in the new plant. Experience, capacity and natural adaptability have specially fitted Mr. James for this undertaking and for the further and enlarged responsibilities that will devolve upon him in the higher position to which he has been advanced. He has an exceptionally thorough understanding of all the mechanical interests of the company, having been identified with the department since September, 1876, when he was employed as a machinist at Easton. In September, 1889, he was promoted to engine house foreman at the same place, and in October, 1895, was transferred to Lehigh. In April, 1899, he was appointed general foreman at Wilkes Barre, and one month later became master mechanic, continuing in that capacity when transferred in October, 1902, from Wilkes Barre to Buffalo.

Mr. G. W. Creighton, general superintendent of the Pennsylvania, became so debilitated lately through overwork that he had to make a trip to New Mexico and California to recuperate. We are gratified to learn that the rest was effectual, and that Mr. Creighton is now feeling as well as he ever was. When he was away a correspondent of the New York *Tribune* made him the subject of the following sketch: "Mr. C. W. Creighton is the general superintendent of the Pennsylvania System east of Pittsburgh. He lives in Altoona, back of the Pennsylvania station, with the steam cars on one side of him night and day and trolley cars on the other. He went down to Deming, N. M., in his private car to get rid of insomnia. His car was sidetracked at the little station, and he thought he had things fixed properly to kill off his sleep destroying ailment. It was so quiet the first night he couldn't get to sleep. He missed the familiar whistling and blowing of engines and the growling of the Altoona trolleys. At 3 o'clock in the morning, after tossing about in his bed all night, the station agent began to bang baggage around in getting ready for the night express. The agent ran the baggage truck up and down, threw around a lot of crates and shot at an owl on the fence across the track. Mr. Creighton went off to sleep in the middle of it all. It was like Altoona."

Deodand.

There was once a curious old statute law in England, which was abolished in 1846. It was called the statute of Deodand and the substance of this law was that a personal chattel which was

the immediate and accidental cause of the death of any reasonable creature was forfeited to the crown, so that it might be applied to pious uses or "given to God" as the word Deodand means. It is probable that this law was the result of the natural horror which is felt for whatever instrument causes the sudden death of any human being. In earlier times the same idea found expression in the Jewish law as set forth in the Bible that if "an ox gore a man that he die, the ox shall be stoned and his flesh shall not be eaten."

This statute of Deodand had some curious applications after the advent of railways in England. In 1838 a locomotive on the Liverpool and Manchester Railway was "fined" about £20 for exploding and killing the engine driver. In 1839 there was what we would call a rear collision in which several people were killed and the locomotive causing the damage was "fined" about £1,400 for the death of the victims. In earlier days money so derived would have been used to pay for masses for the repose of the souls of those who had been done to death.

Two Serious Objections.

When the Highland Railway, in Scotland, was first opened many of the operating force went from other railways. One station agent, well known for piety and other characteristics, went from the Midland Railway and took charge of a station in Invernesshire. He had not been long away when he applied for reinstatement to his old position, and after considerable persistence got possession in his old Lowland station.

When Blyth, the name of this railway man, was questioned why he did not settle in the Highlands, he replied: "Well, there were two good reasons for my dislike to the Highlands; first, they did not preach sound gospel, and, second, they watered the whisky."

Catalogue T of the Hills & Jones Company, of Wilmington, Del., has been received. If you want to get a good idea of the variety of tools for working plates, bars and structural shapes send for a copy of this catalogue. You can have it if you write to the company. There are a great variety of punches to begin with, all exceedingly well illustrated with number, name and brief description attached. Multiple heavy punch and plate shear, heavy plate shear, multiple punches of many varieties, Guillotine frame bar shear, Universal shears, double angle shears, plate bending rolls, plate planing machines, motor or belt driven, all follow and are appropriately classed. Persons not familiar with the state of the art will be surprised at the variety and all will be interested in Catalogue T.

Things Are Not Always What They Seem.

Sailors often imagine that they have a perfect right to call everybody "land-lubbers," who do not habitually "go down to the sea in ships." Whether they are wise in doing this does not matter, but the habit of judging a man by his appearance is as full of the possibility of mistake now as it ever was. Some years ago a marine engineer who had attained the dignity of chief on a certain trans-Atlantic line had become somewhat careless as to his personal appearance, and to put matters plainly, when he was not in uniform, he looked for all the world like a well-to-do farmer. This gentleman had been so accustomed to "occupying his business in the great waters" that he had almost completely forgotten what a locomotive engine looks like.

Having occasion to travel from Boston to New York he arrived at the railway station a quarter of an hour or twenty minutes before train time, and having passed the gatekeeper sauntered down the platform to where a well-groomed 4-4-2 was puffing lazily with full auxiliary and main reservoir pressure and few leaks. The engineer was "oiling round."

The sailor man was at once attracted by the air pump, and thinking this was something new, he pointed at it and accosted the engineer, saying:

"Will you kindly tell me what is that machine you have hoisted up something above the deck line?"

The engineer looked at the chief engineer for a minute and mistaking him for a hayseed from the West, replied:

"Well, say, Boss, that thing ain't nothing to churn butter with."

"Yes, I can see that, young feller," said he of the rudder and the starting bar, "I know enough about this railroad company to know that they ain't such blankety, blank, blank fools as to trust a good churn with a one hoss cuss like you."

A "Dumb Bell" Frame Repair Job.

A neat way of making temporary repairs on a broken locomotive frame may be seen by a visitor to the shop at Fidler's, on the Central Railroad of New Jersey. You will not find Fidler's on the road's time table, but that is nevertheless the name of the Jersey City shops.

Our sketch shows the high, back, corner of the right frame as it slopes down from the rear driving box of one of the Jersey Central's flyers. The crack is from the inside toward the top, as one would naturally expect, and is within an inch of actually being through. The method of holding this frame together is ingenious, and Mr. Hugh Montgomery, the general foreman, says that no trouble has been experienced with a similar piece

of repair work which he did to another engine with broken frame. It gave perfect satisfaction until the engine went into the back shop.

This method of frame patching we may call the "dumb bell" plan, as the piece put in bears a rough resemblance to a dumb bell. A pair of holes, 2 ins. in diameter, are drilled in the frame to a depth of $1\frac{1}{2}$ ins. The centers of these holes are $6\frac{1}{2}$ ins. apart, and they are equally spaced on each side of the crack. A series of holes are then drilled between the large ones to the same depth, but only $1\frac{1}{2}$ ins. in diameter, and the little pieces left between the holes, which architects would probably call "cusps," are chipped out, and the outline of a dumb bell is thus cut in the frame.

The "dumb bell" is of good iron and is made to just fit when quite hot, so that when it cools the contraction is sufficiently powerful to draw the cracked surfaces together and hold them tightly. There is a second "dumb bell" on the

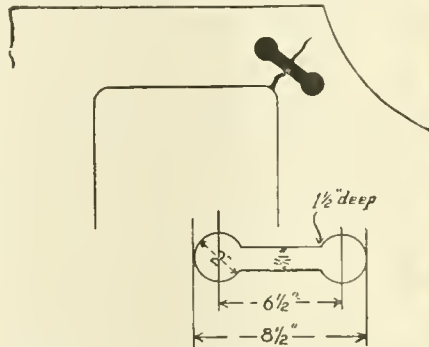

REPAIRS TO A CRACKED ENGINE FRAME.

other side of the frame, so that though the cutting out of so much metal does actually weaken the corner, it nevertheless practically makes it as good as ever.

This dumb bell form of the holding link is good, for the reason that there are no corners in the metal from which cracks may start; there are no bolts, nuts or threads to pull with or to work loose. In other words, nature and not man puts the strain on the iron when hot metal cools. Tyndall tells us that the forces which we are accustomed to work with and which we know something about, large and powerful though they be, are yet as almost nothing when compared to the forces which act between the molecules of matter, as in the case before us.

The breaking of frames over the boxes and the clever piece of repair work here shown is nevertheless an object lesson on the necessity of always keeping pedestal binders up and fitting them snug, even if it does now and then make them a little hard to take down.

Railways are next to the invention of printing—the most powerful instrument of civilization that the ingenuity of man has ever devised.

"Use Dixon's Graphite?"

OF COURSE I DO!"

That's what a locomotive driver told one of our men the other day, when asked if he used Dixon's Flake Graphite. "I put it through the relief valve whenever she groans and a little in the oil cups whenever the pins warm up, and it does the trick every time."

That's the reply hundreds of engineers the country over will give. They look upon the Dixon Company as one of their good friends, helping them to pull heavy trains more easily, to take stiff grades at better speed, to run under, and not over, oil allowances; to keep bearings cool on the road, avoiding delays; to keep their locomotives out of the shop and to keep *themselves* in the good graces of those higher-up.

It's what a man does that counts for him. It's what Dixon's Pure Flake Graphite has done to ease the troubles of the locomotive engineer that makes them say "of course I use it" and welcome a Dixon man.

We will send Booklet 69-C and a sample to anyone who hasn't tried this perfect lubricant.

JOSEPH DIXON
CRUCIBLE CO.
Jersey City, N. J.

Do You Boil Glue?

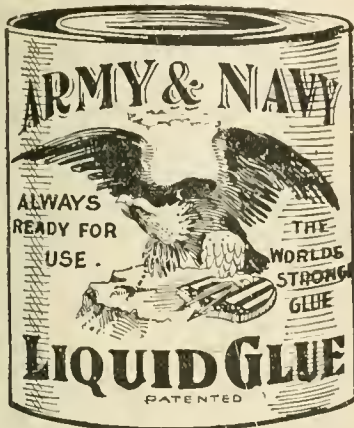

ARMY & NAVY LIQUID GLUE

does away with this work. A pure hide and sinew glue in liquid form. No smell; clean and convenient. Will reduce your shop expense for this line of work twenty-five per cent. **The Glue of the Twentieth Century.** Put up in cans, kegs and barrels.

Not a Fish Glue

Samples for testing and prices are yours for the asking.

WACHTER MFG. CO.
BALTIMORE, MARYLAND

A Railroad "Woodman."

If you go out to the Elizabethport shops of the Central Railroad of New Jersey you ought to get Mr. G. L. Van Dorn, the shop superintendent, to show you a very busy railroad "woodman" or woodchopper, or whatever he or you like to call it.

The apparatus which is reproduced in our illustration, is a wood splitter modeled on the guillotine principle. It stands in the yard, and it consists of an upright frame with a pair of guides at each side on which slides the ram. The ram is a heavy casting with a die attached to its underside, very much in the same way that a die is attached to a steam hammer ram. To this die is riveted a strong, wide, but not very sharp knife, which nevertheless does the business in remarkably short order.



A RAILROAD WOODCHOPPER.

The operating part of the mechanism consists of a piece of 8 in. pipe standing on one end and open at the other. A piston works up and down in this pipe with a stroke of about five feet. The piston rod is attached to the ram by means of a link and pin, so that the ram simply hangs from the rod, and the pin connection permits a certain freedom of movement between them. A coil spring is interposed between pin and bottom of rod to take up the shocks which are necessarily produced in the working of the apparatus.

At the bottom of the 8 in. pipe there is a flat cast iron base with stuffing box for the piston rod. At one side of the base, air pressure from the shop is introduced into the cylinder below the piston, which causes the piston to ascend; thus the normal position of the "chopper" is

with the piston at the top of the cylinder and the knife as far from the ground as it will go. The ram, knife, die, etc., weigh something over 1,000 lbs. and this the air pressure holds up, and when the cylinder is full, there is no further loss of air.

At the other side of the base casting, from where the air enters through a 3/4 in. nipple; there is a 2 in. gate valve opening to the atmosphere. This gate valve is kept shut by the action of a coil spring, and it is opened by the movement of a lever which is conveniently placed for the operator. When a stick of wood has been placed in position on the iron plate below where the knife will fall, the operator suddenly pulls the gate valve wide open, and the piston, ram and die feel as the bottom had dropped out of creation and proceed to "fall down" in strict accordance with the universal law of gravitation as stated by Newton in 1687. The log of wood on the iron plate below, being entirely unable to resist, "goes to pieces" at once.

It is usually a difficult thing for a railway company to keep its engines well supplied with kindling wood, or to get rid of its old wood, but the difficulty on the C. R. R. of N. J. just now is to give the Van Dorn woodchopper all it would like to tackle. There is, of course, as an adjunct to the "chopper" an ordinary circular swing saw in a shanty nearby. This saw reduces to the proper length all the logs, sticks, beams, etc., which come along. The saw table can be run down opposite the guillotine and the wood is then thrown under the knife and split up. One blow has been sufficient to split a 14x16 in. stick, and even a 3/4 bolt imbedded and hidden away in a log, has been cut in two while the operator merely thought he had come across a knot.

When everything is working satisfactorily about 14 cords of locomotive kindling wood can be turned out in a day. The machine is strong and is easily and cheaply made and is as useful as it can be, and when it comes to wood splitting contrivances this home made machine is very near the center of the stage and considers itself entitled to a good deal of the lime light. It is certainly always "among those present."

The Safety Car Heating and Lighting Company, of 160 Broadway, New York, are giving to those who write for it a very neat little memorandum booklet to visitors at their St. Louis Fair exhibit. It is of convenient size for the pocket and has blank pages for exposition notes, etc. It contains a list of the company's exhibits, and where they are to be found. A few pages in the middle of the book are taken up with some observations on car lighting. Pintsch gas is made by the destructive distillation and gasification of oil of a

proper quality. This is effected in red-hot retorts and produces a permanent gas. This gas is purified and compressed into storage tanks, from which it is distributed through pipes extending from the place of manufacture to the various railroad yards. It is, as occasion requires, drawn off into car receivers and these are filled to a pressure of 10 atmospheres. A statement recently issued by the Julius Pintsch Company, of Berlin, shows that at the close of 1903 this system was in extensive use all over the civilized world. They had then 128,881 cars, 5,806 locomotives, 372 gas works and 1,426 buoys and beacons equipped for the use of Pintsch gas. The Safety Car Heating and Lighting Company will be happy to give any information to those who are interested enough to ask for it.

Unwieldy Definitions.

That great English philosopher, who has been aptly spoken of as almost the "last of the great thinkers of the Victorian era," and whose writings have had such a wide circulation in this country, once defined the doctrine of organic evolution as "a change from an indefinite, incoherent homogeneity; to a definite, coherent heterogeneity, through continuous differentiations and integrations." This learned explanation has been humorously paraphrased by an eminent mathematician, Prof. Kirkman, who translated Spencer's definition into "Evolution is a change from a no-howish, untalkaboutable, all-alikeness; to a somehowish and in general talkaboutable, not-all-alikeness, through continuous somethingelseificatious, and sticktogetheratious."

All this may be very accurate and in the last example, very amusing and in either form might suit a Philadelphia lawyer, but the average man does not take to it readily because the words used are too long. What we all want are clear, sharp definitions put down squarely in short, easy words. The science of engineering requires that its truths be clearly stated, and not put in the form of unwieldy definitions.

We handle a lot of engineering literature and we want you to judge if what we offer is not put in language which is short, sharp and concise. Look over our list and see for yourself. You will not find any word puzzles, you will get facts and the practical experience of the men who write.

The first on the list is, of course, RAILWAY AND LOCOMOTIVE ENGINEERING, a practical journal of railway motive power and rolling stock. It costs only \$2.00 a year, and is well worth the money, and besides the paper is a welcome visitor in every household. Let your wife and children see it.

"Twentieth Century Locomotives,"

Angus Sinclair Co., deals comprehensively with the design, construction, repairing and operating of locomotives and railway machinery. First principles are explained. Steam and motive power is dealt with, workshop operations described, valve motion, care and management of locomotive boilers, operating locomotives, road repairs to engines, blows pounds in simple and compound engines, how to calculate power, train resistance, resistances on grades, etc. Shop tools explained. Shop receipts, definitions of technical terms, tables, etc. Descriptions and dimensions of the various types of standard locomotives. The book is well and clearly illustrated and is thoroughly up to date in all particulars, fully indexed. Just off the press. Price, \$3.00.

"Locomotive Engine Running and Management," by Angus Sinclair, is an old and a universal favorite. A well-known general manager remarked in a meeting of railroad men lately, "I attribute much of my success in life to the inspiration of that book. It was my pocket companion for years." We sell it for \$2.00.

"Practical Shop Talks." Colvin. This is a very helpful book, combining instruction with amusement. It is a particularly useful book to the young mechanic. It has a stimulating effect in inducing him to study his business. The price of it is 50 cents.

"Examination Questions for Promotion." Thompson. This book is used by many master mechanics and traveling engineers in the examination of firemen for promotion and of engineers likely to be hired. It contains in small compass a large amount of information about the locomotive. Convenient pocket size. We cordially recommend this book. The price is 75 cents.

"Compound Locomotives." Colvin. This book instructs a man so that he will understand the construction and operation of a compound locomotive as well as he now understands a simple engine. Tells all about running, breakdowns and repairs. Convenient pocket size, bound in leather, \$1.00.

"Catechism of the Steam Plant." Hemenway. Contains information that will enable a man to take out a license to run a stationary engine. Tells about boilers, heating surface, horse power, condensers, feed water heaters, air pumps, engines, strength of boilers, testing boiler performances, etc., etc. This is only a partial list of its contents. It is in the question and answer style. 128 pages. Pocket size. 50 cents.

"Care and Management of Locomotive Boilers." Raps. This is a book that ought to be in the hands of every person who is in any way interested in keeping boilers in safe working order. Written by a foreman boilermaker.

Keep Your Mind On It



**CRANDALL'S HELIOS
AIR PUMP and
THROTTLE VALVE**

PACKING

**Put Up in Sets
Exact Fit to Rod and Box**

Send Trial Order

The Crandall Pkg. Co.

123 Liberty Street
N. Y. CITY

Chicago Office, 30 La Salle St.



**Over One
Thousand
Miles**

A DAY

on

"The Colorado Special"

Dinner in Chicago Today
Breakfast in Omaha Tomorrow Morning
Dinner in Denver Tomorrow Evening

**SPLENDID TRAIN SERVICE
to DENVER via UNION PACIFIC**

Full Information cheerfully
furnished on application to
G. P. and Tkt. Agt.,
Omaha, Neb.

H. S. PETERS' BROTHERHOOD OVERALLS

have gone to almost every part of the World where Overalls are worn and are everywhere conceded to be the **BEST**. Every point of material, cut, construction and finish is carefully looked after; the only way that superiority can be attained. Every garment is absolutely guaranteed. The Patented, Fleece-lined, Safety Watch Pocket is alone worth a whole suit of any other make.

I'll send sample suits, charges paid, to any place in the World where mail or express goes, where I have no retail agency; sample materials and full particulars for the asking.

UNION MADE
OF COURSE -
B.L.F. 3 - H.S. PETERS - B.L.F. 171
DOVER, NEW JERSEY, U. S. A.

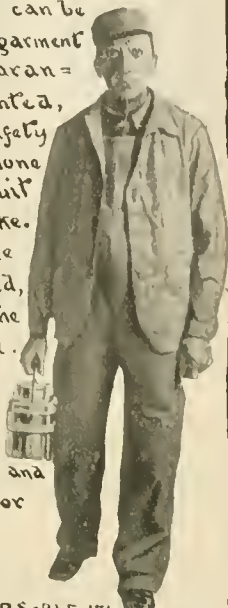

The Twentieth Century Master Mechanic

Won't use solid Mandrels. Cost too much, take up too much room and don't give satisfaction.

Nicholson Expanding Mandrels

Take everything from 1 to 7 inch holes. Take up little room—always ready and you can buy four sets for the cost of one of the solid kind.

Are You Using Them ?

Catalogue tells you more about them.

W. H. Nicholson & Co.
Wilkesbarre, Pa.

Also contains several chapters on oil burning locomotives. Price, 50 cents.

"Locomotive Link Motion." Halsey. Any person who gives a little study to this book ceases to find link motion a puzzle. Explains about valves and valve motion in plain language, easily understood. Price, \$1.00.

"Machine Shop Arithmetic." Colvin and Cheney. This is a book that no person engaged in mechanical occupations can afford to do without. Enables any workman to figure out all the shop and machine problems which are so puzzling for want of a little knowledge. We sell it for 50 cents.

"Firing Locomotives." Sinclair. Treats in an easy way the principles of combustion. While treating on the chemistry of heat and combustion it is easily understood by every intelligent fireman. The price is 50 cents.

"Skeevers' Object Lessons." Hill. A collection of the famous object lesson stories which appeared in this paper several years ago. They are interesting, laughable and best of all they are of practical value to-day. \$1.00.

"Stories of the Railroad." Hill. Best railroad stories ever written. Those who have not read these stories have missed a great literary treat. \$1.50.

"Standard Train Rules." This is the code of Train Rules prepared by the American Railway Association, for the operating of all trains on single or double track. Used by nearly all railroads. Study of this book would prevent many collisions. Price, 50 cents.

"Mechanical Engineers' Pocket Book." Kent. This book contains 1,100 pages 6x3 1/4 inches of closely printed minion type, containing mechanical engineering matter. It ought to be in the bookcase of every engineer who takes an interest in engineering questions. We use it constantly as a reference for questions sent to us to be answered. Full of tables and illustrations. Morocco leather, \$5.00.

"Locomotives, Simple, Compound and Electric." Reagan. An excellent book for people interested in any kind of locomotive. It will be found particularly useful to men handling or repairing compound locomotives. It is the real locomotive up to date. \$2.50.

RAILWAY AND LOCOMOTIVE ENGINEERING. Bound volumes. \$3.00.

"Climax" Car Vestibule Diaphragms.

It is a fact though perhaps unnoticed by those not directly connected with the transformation, that no part of a vestibule passenger car has undergone so complete a change in the matter of general practice as the diaphragm has within the past three years. In that short time the rubber diaphragm has come to be almost universally supported by a diaphragm made of canvas belting. There is

nothing strikingly new about diaphragms made of canvas belting, as the first full sized sectional model prepared for Mr. Sessions, the inventor of the Pullman vestibule, was made of belting riveted together and the second was of rubber belting cemented together. The latter form was adopted by Mr. Sessions, and was for many years universally used, until the quality of the material supplied so far deteriorated that the average life of rubber diaphragms was reduced to two and one-half years. About the same time the Wagner vestibules were equipped with canvas-sewed diaphragms, many of the original being still in service on the Northern Pacific road. Several roads began about 15 years ago to substitute canvas-sewed diaphragms, among them being, as we said, the Northern Pacific, also the Atchison, Topeka & Santa Fe, the Chicago, Rock Island & Pacific, the Chicago, Milwaukee & St. Paul and Chicago & Northwestern. Later on several other roads followed, but it was not until January, 1901, that a canvas diaphragm was commercially made.



"CLIMAX" DIAPHRAGMS.

The reduced first cost being fully one-half, and the durability several times as great, this form of diaphragm found ready sale, but about a year later, the riveted form was abandoned by the manufacturing firm, and a sewed diaphragm was substituted.

This new form proved to be very popular and the sales of the riveted diaphragm dropped from about 500 in May, 1902, to 36 in December of the same year, while in the same period of time the sales of the sewed type increased from 30 to 895. This sewed form met the requirements very well in some respects, but car builders soon found that to hold up the crown top, and prevent sagging, a stronger corner could be produced and a more substantial binding could be used, capable of resisting wear and the effects of the elements, and an adjustable foot or bottom made which could be cut off without the material unravelling thus preventing danger of burning.

To meet these requirements the "Climax"

max" diaphragm has been put on the market by the same firm which originally, and for several years later, exclusively supplied diaphragms to the Pullman Company. The "Climax" is ordinarily bound with belting leather, the grain being used for the inside, and the split, which is capable of being more thoroughly water and weatherproofed, is used on the outside, where rawhide or other binding can be used.

The corners of the "Climax" are constructed on mechanical lines so as to form a keystone at the top and thus prevent sagging. It eliminates two of the five parts common to each leaf, and which are used in all other constructions. Each corner is made by inserting a solid leather fillet, triangular in shape as shown in our illustration. This is the thickness of the belting so that it prevents cutting away material at the corners and allows the inside of the belting to form a perfect rectangular joint. The upright and longitudinal sections are then securely "tied" by two heavy locked stitches practically parallel. Then when the heavy binding is applied the sections are absolutely "framed" in as can be seen in figures.

To prevent errors due to shrinkage or variations in car heights and to furnish a durable wearing part where the diaphragm rubs against the lower buffer-plates and at the same time to allow the bottoms to be trimmed to a proper fit and to prevent the material from unraveling, rubber packing feet are used. The "Climax" is treble sewed throughout with a locked stitch of 8-strand Irish linen thread, one seam is sewed through the edges of the belting before the binding is applied and is thus absolutely protected from the weather, and two more seams are spaced about a quarter of an inch apart through the binding.

The diaphragm is being sold in large quantities and when exhibited at the April meeting of the Western Railway Club, met with the hearty indorsement of the members present, many of them being users. The contour of the Pullman, Gould, American Car & Foundry and the Buhop types are shown in the illustration. The corner construction of the Gould is similar to the Pullman type, differing only in dimensions and number of folds or leaves. In all other types the same relative points of betterment are retained. Where rivets are asked for on the Pullman type they are supplied without extra cost, but one of the three seams is omitted to make room for the insertion of the rivets.

We may mention that Mr. Warren M. Salisbury prepared the models for Mr. Sessions and supplied the first diaphragm ever applied to a passenger car. Patents fully covering the essential features of this diaphragm have been allowed by the U. S. Patent Office, and,

remarkable as it may appear, there was not a single citation as to infringement. The "Climax" is manufactured by W. H. Salisbury & Co., 109 Madison street, Chicago, where they have established a complete factory and the department is under the management of Mr. Fred F. Bennett, well-known in connection with the manufacture and sale of canvas diaphragms.

Roundhouse Foremen.

At the May meeting of the New York Railroad Club, there was an unusually interesting discussion on Mr. W. O. Thompson's paper on the Roundhouse Foreman. Mr. George Bourne displayed particular intimacy with the difficulties of a roundhouse foreman's life. He said:

I do not think that any of us who have bumped into the roundhouse question and hit it good and hard will attempt to look for an ideal roundhouse foreman, because if we got him, and he had brains enough to make a good, ideal roundhouse foreman, he would surely have brains enough to get out of the job. But I think the paper of Mr. Thompson opens up some very important subjects that are probably as important to the mechanical men today as any we have. I think that a roundhouse foreman, to get the best out of the facilities he has, should be in touch with the division officer of his department. In other words, I think the roundhouse should be under control of the mechanical superintendent, so that the man who is running the organization can get in touch with his subordinates and in that way get the best out of them and be thoroughly in sympathy with the men who are doing the work.

The question of maintaining power between shoppings is one in which all mechanical men are vitally interested and I believe this can be best accomplished by building up the roundhouse organization, and I think that if the roundhouses had been strengthened to the extent that the machine shops have, taking into consideration the way the power has increased, that the roundhouse troubles would have decreased more than they have. On a great many roads the roundhouse foreman is practically a head hostler, so far as control of his organization is concerned. The roundhouse foreman, more than any other foreman connected with the mechanical department, should have complete control over his organization. The fact of his having to exercise his judgment and know when an engine can make another trip before being attended to is one of the main reasons why he should have absolute control of the men that are under him, and be responsible for the whole roundhouse organization.

I was talking with a superintendent of motive power last week and the roundhouse foreman question came up. He told me he really did not know where

Handy Folding PILOT COUPLER

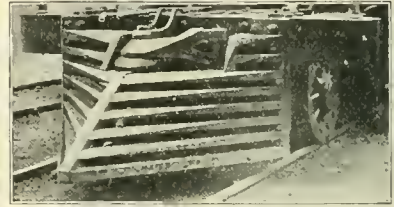

A safe and neat construction for front ends of road locomotives

Handy Car Equipment Co.
Old Colony Building
Chicago

The TAYLOR- NEWBOLD Saw

Cuts easily a .35
carbon forging
9 ins. by 14 ins.
in 17 minutes

Inserted Cutters
treated by the
Taylor-White
Process under
exclusive rights
30 Cutters in 36 in.
Saw may be changed
in 12 minutes

A set of cutters
hardly dulled in
two weeks' con-
tinuous cutting
night and day

THE TABOR MFG. CO.

18th and Hamilton Sts.
PHILA., PA.

30-32 South Canal Street
CHICAGO, ILL.

84 Mason Building
BOSTON, MASS.

49 Deansgate
MANCHESTER, ENG.

Fenwick Freres
PARIS

Schuchardt & Schutte
BERLIN

FEWING'S CAR & ENGINE REPLACER



RE-PLACE-ER

RAILWAY APPLIANCES CO.
SUCCEEDING
Q & C COMPANY
OLD COLONY BUILDING, CHICAGO.
114 LIBERTY ST. NEW YORK.

to look for material to make roundhouse foremen out of. He had considered two ways of getting them: One was to take likely men out of his drawing office and make them assistant roundhouse foremen; the other one, to take these same men and make them assistants to the division master mechanic—really a second pair of eyes and ears in the master mechanic's office, for nine months or a year, so that these men, who should have the faculty of acquiring the necessary information quickly, due to their previous training, might have an opportunity to get the practical experience that it is necessary for a roundhouse foreman to have.

My experience as a roundhouse foreman is not quite so bad as Mr. Sinclair's. We did not have pumps when I was running a roundhouse, but we had a great many other things that were equally as troublesome. I left a nice, easy position running an 18 in. x 24 in. engine and on which I probably worked from 20 to 24 days per month and for which work I drew from \$150 to \$175 per month; took a job as roundhouse foreman at \$125 per month, working every day in the week, averaging 14 hours per day, and part of several nights per week; had five superiors to satisfy, yet I myself did not have enough authority to say that such and such a man was a good man and I would like to keep him, or that another man was a poor man for roundhouse work and I would like to get rid of him. I had men who were good roundhouse men only getting from 20c. to 22c. per hour; I had back shopmen getting 30c. and 32c. per hour who were capable of doing good work in an erecting shop, yet they were not the class of men who were doing their best in a roundhouse. It is not always the best mechanic who makes the best roundhouse man. I have seen men who were commonly called "bum machinists" or "bum boilermakers" who probably never held one position very long, but who fitted into the work the first day they started in the new job. These men were good roundhouse men. If the transportation department was waiting for an engine which upon arrival was found to need tube work, you could knock out the fire and this class of men would oftentimes get in and calk tubes while the engine had from 80 to 100 lbs. of steam on it. It is seldom you can do this with good back shopmen; as a matter of fact, they will not work in the roundhouse. I think if the roundhouse foreman had control over his organization and was able to get the class of men suited to that particular work, the condition would be better, and if we can make the conditions better there will be some inducement for good men to stay in this position.

I think we all recognize that in warming a roundhouse we must have complete circulation and with the engines going

in and out this is very hard to get. I have yet to see a roundhouse in which the circulation was any good in winter. Sometimes old methods receive a little reconsideration. A very prominent motive power man outlined to me the other day a scheme for going back to the old method of covering the center of the roundhouse. He had given the matter a great deal of thought and he figured it could be done for about \$150 or \$500 per pit. He expected to gain by it the ability to heat his roundhouse in winter, keep the men comfortable, so that they could do their work and in consequence be satisfied with a tolerably comfortable job. The men could get across from one side of the roundhouse to the other much quicker than by taking the circular way and he thought it would be a profitable proposition to cover that center part of the roundhouse. I think a great deal of delays, especially at the busy points, are due to the time that is taken to turn engines, and I thought that old idea was worth a little reconsideration—the way he outlined it to me.

A New Rip Saw.

Our readers being interested in the progress made in the building of ma-

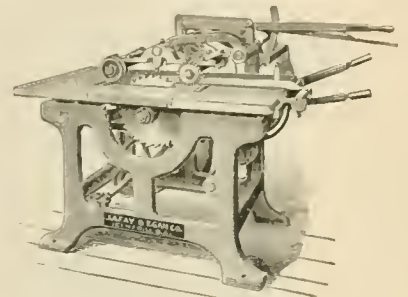

No. 110. NEW SELF FEED RIP SAW

chines designed to help them in their work, are at all times willing to investigate the merits of the new ones brought out. But newness alone will not answer the purpose; this must be one of the points only, for this will not make up for any mechanical defects. It is therefore our pleasure to here illustrate a rip saw which is both new and improved, and which is fully warranted by its makers. Ripping machinery has always been one of their most successful specialties, and this tool is their newest and one of their best products. They introduce it on the market with the confidence that it will meet with the success their others have met because there is a demand now for a machine of just this character. It is of medium size and designed for general work in wood working factories, and short or long stock can be ripped at a very high speed with equal facility. Speeds to 160 feet per minute can be furnished.

The feed consists of feeding-in and feeding-out rolls, powerfully geared, and 5 inches in diameter. The rolls are adjustable to and from the saw, so that if a small blade for fine ripping is used, they

GINSENG Fortunes in this plant. Easily grown. Roots and seeds for sale. Ratoon in your garden. Plant in Fall. Booklet and Magazine 4c. OZARK GINSENG CO., DEPT. Y-15, JOPLIN, MO.

Ball's Official R. R. Standard Watches

16 AND 18 SIZE.



17 AND 21 RUBY JEWELS, SAPPHIRE PALLETS

BALL'S IMPROVED SAFETY DOUBLE ROLLER

Are without question the finest watches that American talent and skilled labor can produce, and they are giving such universal satisfaction that we have no hesitancy in claiming that they are the best and safest railroad watch on the market.

Tests severe and numerous have proven this fact to the most critical users in all sections of the country, to which thousands of good Railroad and Brotherhood men are ready to certify.

We have an authorized agent in nearly every railroad center. Call on him for information and facts. Write us for descriptive matter.

The Webb C. Ball Watch Co.
Watch Manufacturers
Ball Building, Cleveland, Ohio, U. S. A.

can be adjusted close to the saw on each side, thus insuring a feed which will not tear or twist the work. The table can be easily raised and lowered to accommodate itself to larger or smaller saws, and when grooving heads are used can be adjusted to suit exact depth of cut. The largest saw used is 16 inches in diameter, and when table is at its lowest point the saw projects 5 inches above the table.

Further particulars about this machine can be had on applying to its makers, J. A. Fay & Egan Company, No. 445 West Front street, Cincinnati, Ohio, who will also send free to those interested and who will write for their new illustrated catalogue of wood-working machinery.

Standard Pipe Threading and Cutting Machine.

The annexed engraving is the Standard Pipe Threading and Cutting Ma-

necessary armature and shunt field resistance, which is used in connection with the controller for operating the motor at its various speeds. This resistance is self contained, and is so constructed that it is practically indestructible, the resistance wires being entirely enclosed in special iron box castings, making same both oil and fire proof.

Mead-Morrison Manufacturing Company, of Cambridge, Mass., have assumed the coal handling business of the John A. Mead Manufacturing Company, of New York. The directors are: Eugene N. Foss, treasurer B. F. Sturtevant Company, Boston, Mass.; John G. Morrison, president Rawson & Morrison Mfg. Co., Cambridge, Mass.; W. S. Martin, manager, N. H. and Vermont, Mass. Mutual Life Ins. Co., Manchester, N. H.;

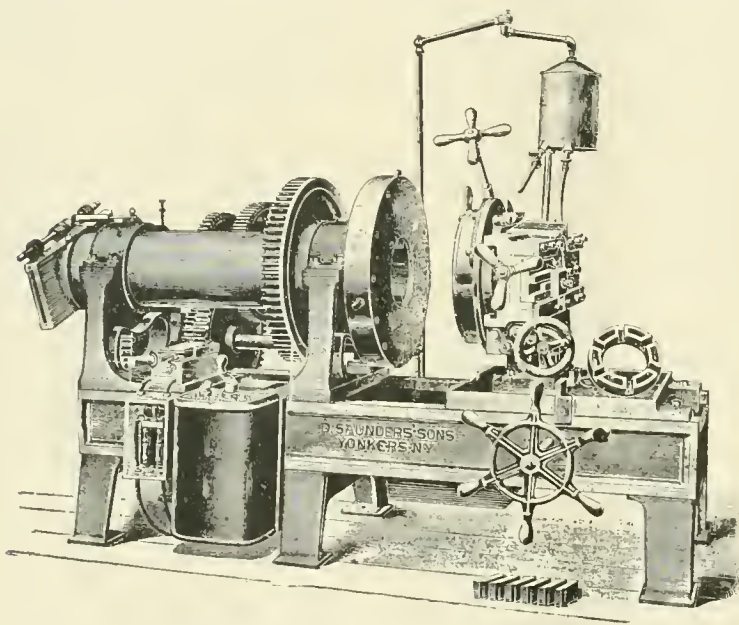

SAUNDERS' PIPE THREADING MACHINE.

chine, made by D. Saunders' Sons, Yonkers, N. Y., and it is very favorably known in railway shops. The engraving represents Nos. 5 and 6 machines with direct connected electric motor. The electrical equipment consists of a standard round type Lundell motor, standard rotary controller for forward or reverse speeds, armature and field resistance, circuit breaker and main line switch. Motor is compound wound, operating at standard rates of speed. It is entirely inclosed, having suitable trap doors at commutator end, to enable access to be had to brushes and commutator. Upon the motor shaft is mounted a suitable steel pinion which meshes with a cast iron cut gear wheel located upon the driving shaft of the machine. The motor is substantially mounted upon cast iron brackets, which are bolted fast to the bed of the machine. Beneath the brackets is fastened the

Arthur P. French, attorney, Boston, Mass.; Benjamin D. Brown, vice-president, John A. Mead Mfg. Co., New York; Col. W. J. Hoyt, capitalist, Manchester, N. H.; and the company will be officered as follows: Eugene N. Foss, president; W. J. Selleck, vice-president and western sales agent; John G. Morrison, treasurer; W. S. Martin, Jr., general manager; Orton G. Dale, manager of New York office; A. E. Norris, consulting engineer; F. W. Scott, superintendent. The offices will be at 31 Main street, Cambridgeport, Mass.; Kimbark avenue and 74th street, Chicago, and 11 Broadway, New York. The company will manufacture at Cambridge, Chicago and Rutland, Vt., and will follow out those general lines which have made the John A. Mead Mfg. Company so successful, and will enlarge the plant and working scope sufficiently to keep abreast of of the trade.

168 p. **BOOK** on

AIR AND GAS COMPRESSORS

FREE

to anyone who will **TELL US WHERE** compressed-air apparatus is to be installed. It contains valuable **Formulae, Tables and Information.** Write now. : :

LIDLAW-DUNN-GORDON CO.

116 Liberty Street
NEW YORK

Flexible Spout

Vertically in straight line. Also laterally. The latest improvement to

Poage Water Columns

American Valve and Meter Company
CINCINNATI, OHIO.

SEND FOR CATALOGUE

THE DROP SEAT DROPPED.

Shipped Locomotive Builders several large consignments last year. Ask for our seats when your company is ordering new engines. The Mexican Central Ry. Co. is putting our drop seat No. 7 on all their new engines. We make 20 different styles of Locomotive Cab Seats, \$2 up. Send for new Catalog D containing 100 illustrations and full particulars, free. Send 10c. for Complete Camper's Manual; or, How to Camp Out and What to Do, a practical book of 130 pages, worth \$1.

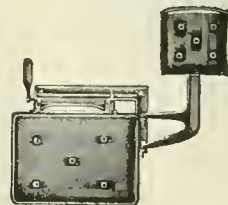

STANNARD & WHITE CO., Racine Jct., Wis.

Besides **ASHTON** LOCOMOTIVE STEAM GAGES



WE MAKE
 Duplex Air Gages
 Gage Testers
 Blow-off Valves
 Chime Steam Whistles
 Pop Valves

ALL OF A SUPERIOR QUALITY

Catalogue L on Application

The Ashton Valve Company, 271 Franklin Street, Boston, Mass.

American Locomotive Sander Company

13th & Willow Sts., Philadelphia, Pa.

Proprietors and Manufacturers,

LEACH, SHERRURNE, DEAN, HOUSTON, "Sue" and CURTIS

SANDERS

JUST PUBLISHED
 — THE —

LOCOMOTIVE UP TO DATE

The greatest accumulation of new and practical matter ever published treating upon the construction and management of modern locomotives, both

SIMPLE and COMPOUND

By **CHAS. McSHANE**

Author of "One Thousand Pointers for Machinists and Engineers," Special Exhaustive Articles were prepared for this new book by the

- Baldwin Locomotive Works
- Rogers Locomotive Company
- Schenectady Locomotive Works
- Pittsburg Loco. and Car Works
- Brooks Locomotive Works
- Dickson Locomotive Works
- Cooke Loco. and Machine Co.
- Richmond Loco. and Machine Co.

With contributions from more than one hundred prominent railway officials and inventors of special railway appliances.

736 Pages, 6x9 inches 380 Illustrations
 An Absolute Authority on All Subjects relating to the Locomotive

Bound in Fine Cloth, \$2.50

ONE THOUSAND POINTERS

— FOR —

MACHINISTS and ENGINEERS

By **CHAS. McSHANE**
 (Practical Machinist)

Assisted by CLINTON B. CONGER, Air Brake Expert; J. P. HINE, Mem. Div. 37, B. of L. E.; J. G. A. MEYER, Mechanical Engineer; W. M. F. GOSS, Mechanical Engineer; JNO. C. WHITE, Indicator Expert. The only complete work on the locomotive combining both theory and practice. 342 pages, 187 illustrations.

BOUND IN FINE CLOTH, \$1.50

The only book ever indorsed by the International Association of Machinists. Agents wanted everywhere; write for terms, commissions and club rates. Will be sent prepaid to any address upon receipt of price.

GRIFFIN & WINTERS, Pub.

171 La Salle St., CHICAGO, ILL., U. S. A.

Vest Pocket Combination Tool

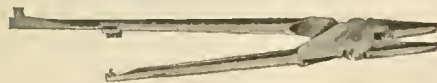

Wire Cutter, Screw Driver, Glass Cutter, Packing Hook and Burner Grip. Weight 4½ oz. Drop Forged Steel. Always useful. Ever Ready.

In Leather Case. Price, \$1.50

WILLIAMS, FROST & CO.
 WINONA, MINN.

Punch for Small Angles and Tender Plates.

The annexed engraving shows a 30 in. throat style "C" punch with automatic spacing table made by the Cleveland Punch & Shear Works Co., and recently installed in the new shops of the Lake Shore Railroad at Collinwood, Ohio. This machine is designed to punch small angles and tender plates. Table is operated by means of a screw through bronze nut. Any spacing from 1/8 in. to 4 ins. by eighths can be obtained by adjusting the crank at the rear end of the machine. The adjustment is by means of screw. Machine carries two punches and dies of differ-

special 6 yard, two way dump car for contractors' use, brick yards, mining, etc. The Middletown Car Works people will be happy to send any of their folders to those who are anxious to see examples of modern car construction, and will be happy to give any information to intending purchasers or others concerning their products.

A New York daily tells a story of an engineer of an express train being stopped by a red light which was found to be a ren lantern hanging on the horn of a stray cow. The man telling the story tries to emphasize it by saying that in his hurry to stop the engineer reversed his engine

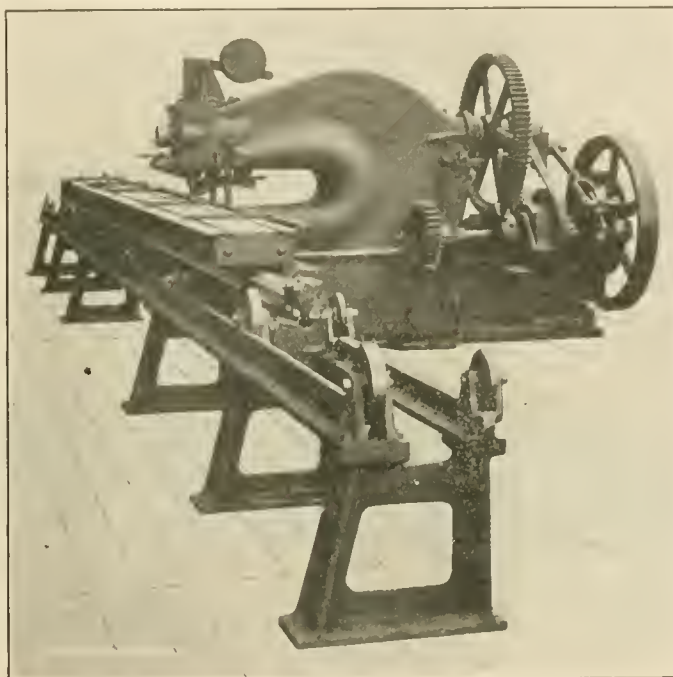

CLEVELAND PUNCH WITH AUTOMATIC SPACING TABLE.

ent sizes, operated by gags, so that holes of different sizes can be punched without removing the work from the table. This is a quick-acting machine, intended only for light work.

and by so doing knocked out a cylinder head. That is a worthless addition to a good yarn. The engineer nowadays does not reverse the engine when he wants to make a quick stop. He applies the air brakes and sands the rails. The rustic reporter, however, persists in saying: "The bold engineer, with the eagle eye, seeing danger ahead, squealed for brakes and reversed his engine."

The Middletown Car Works (Incorporated), of Middletown, Pa., have recently issued some interesting folders giving information concerning freight cars manufactured by them. One of these folders describes a standard 30 ton box car designed and built by this company. This car conforms to the dimensions prescribed by the American Railway Association and is illustrated by an example of those built for the Suffolk & Carolina. A wooden frame 36 ft. flat car of 60,000 lbs. capacity, 9 ft. wide with deep truss rods, is pictured in another folder with appropriate information. In both folders the diamond frame arch bar type of truck with wooden bolsters is shown. A third folder illustrates a

The Rand Drill Company are sending out a mailing card which is a decided novelty. It is in the shape of the new "Imperial" hammer, the address being written on the barrel and a one cent stamp fitting into the handle. On the reverse side are a few lines which suggest more than they actually say.

In ordinary steady labor for ten hours a day, a man exerts about one-tenth of a horse power or an equivalent of raising 3,300 pounds one foot per hour.

Rapid Reduction Double End Axle Lathe.

Our engraving represents a Rapid Reduction Double End Axle Lathe, made by the Lodge & Shipley Machine Tool Company, of Cincinnati, Ohio.

The bed of this lathe is of entirely new design, massive in its proportions. It is provided with separate ways for the carriage and tail stock, the ways for the latter being in the form of a dovetail inclined at an angle to the horizontal in such a manner that the base of the tail stock engages directly into the dovetail, and the up-thrust of the cutting tool is taken directly by the casting instead of on clamping bolts.

The driving mechanism consists of a three-step cone running between self-oiling bearings and having diameters of 20, 25 and 30 in. by $6\frac{1}{2}$ in. face. The inner end of the cone shaft is connected

to the carriage is always at the command of the operator. Automatic stops in both directions for each carriage are provided, and calipering stops can be applied to each tool for duplicating diameters; the combination doing away with considerable measuring and calipering. Shear wipers keep the way free from dirt and grit.

The tailstocks are shaped so as to allow the carriages to pass them when starting a cut at the end of the axle. In using more than one tool, this feature is of the greatest importance. A rack and pinion movement facilitates the movement of both tailstocks to accommodate different lengths of axles, and a pawl in the rear of each engaging in this rack forms a positive lock against the end movement.

The feeds obtainable on this lathe are six in number, as follows: 3, 5, 8, 11, 16 and 32 to one inch, any one of

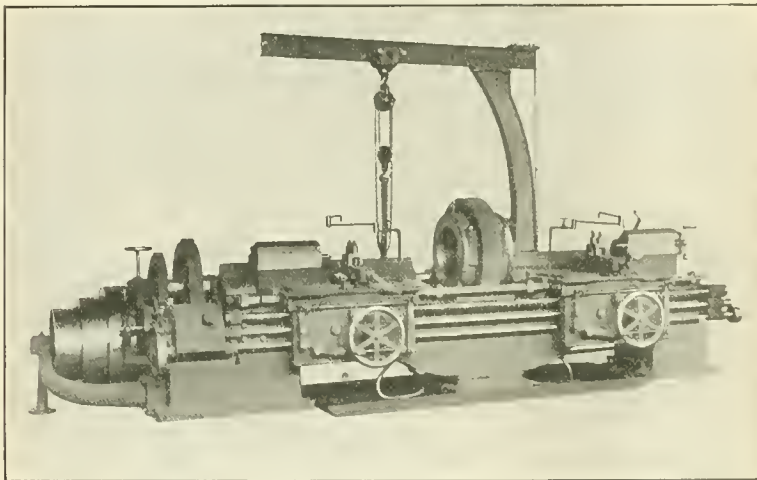

LODGE & SHIPLEY DOUBLE END AXLE LATHE.

through two changes of gearing directly to a short driving shaft at the back of the lathe. This driving shaft is geared into a central driving gear 30 ins. in diameter by 4 in. face, mounted between bearings at the center of the bed. An equalizing driving plate transfers the power to the axle, and a 15-in. opening through the center greatly facilitates the insertion and removal of axles.

The carriages are arranged to take one or more tools, which can be placed anywhere along their length and varying distances apart. The feed, instead of being obtained through a rack and pinion, is provided by a bronze nut 14 ins. long which completely encircles the stationary lead screw, which is cut double thread, one-inch lead. By revolving the nut on this screw a more powerful feed is obtained.

A safety device in the apron prevents both the feed for turning and that for the quick movement being engaged at the same time. The hand wheel move-

ment which can be obtained by a simple movement of a lever at the head of the lathe while the machine is running.

The complete weight of the Axle Lathe, with regular countershaft, oil pump and pan, is about 19,000 lbs.

We have received from Fairbanks, Morse & Company, of Chicago, Ill., a very interesting catalogue on pumping machinery. The pamphlet, which is standard railway size, 9x6 ins., is very well printed and illustrated. It represents on its pages consistent and marked improvement in pump design and the information which accompanies each illustration is full and so disposed that one may get a good idea of what each design is like and what the pump will do. There are a series of cleverly drawn charts in this catalogue for the ordering of material in which the pump is shown in section, and grouped around it are perspective views of each piece, an arrow indicating the connection between

THE NEW BARRETT GEARED RATCHET LEVER JACK

30 Tons Lifting
Capacity.

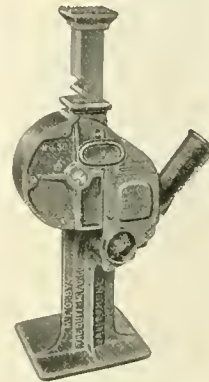

An improved **QUICK-ACTING JACK** for the rapid handling of loaded freight cars, Pullman cars and all heavy loads.

Has the simplicity of an ordinary Lever Jack, the leverage being specially compounded to permit **EASE of OPERATION** and **QUICK-ACTION**.

No complicated features. Cannot get out of order. Send for Special Bulletin "L" and further information.

MADE EXCLUSIVELY BY

The Duff Manufacturing Co.,
Works: Allegheny, Pa. PITTSBURG, PA.

The Union Switch & Signal Co.

Consulting and Manufacturing
Signal Engineers.

GENERAL OFFICES AND WORKS AT
SWISSVALE, PA.

DISTRICT OFFICES:

New York: Central Building, 143
Liberty Street.

Chicago: 1536 Monadnock Building.

St. Louis: Terminal Station.

THE ROBERT W. HUNT & CO.

Bureau of Inspection, Tests and Consultation,
1137 THE ROOKERY, CHICAGO.

66 Broadway, New York. Park Building, Pittsburgh.
31 Norfolk House, London, Eng.

Inspection of Steel Rails, Splice Bars, Railroad Cars, Wheels, Axles, etc. **CHEMICAL LABORATORY**—Analysis of Ores, Iron, Steel, Oils, Water, etc. **PHYSICAL LABORATORY**—Test of Metals, Drop and Pulling Test of Couplers, Draw Bars, etc.

Efficiency Tests of Boilers, Engines and Locomotives.

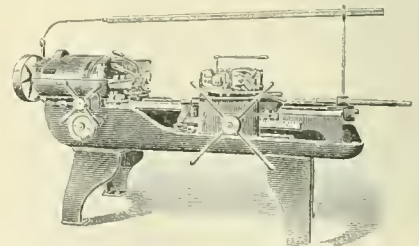

JONES & LAMSON MACHINE CO.

Main Office and Works:

SPRINGFIELD, VERMONT, U. S. A.

A, B, C and Lisber's Code used.

British Office: Jubilee Buildings, 97 Queen Victoria St., London, E. C. France and Spain: Ph. Bonvillain, 6, Rue Blanche, 6, Paris, France. Germany, Belgium, Holland, Switzerland and Austria-Hungary, M. Koyemann Charlottenstrasse 112, Dusseldorf, Germany.

**The ONLY Box
WITH THE ONLY DUST GUARD**

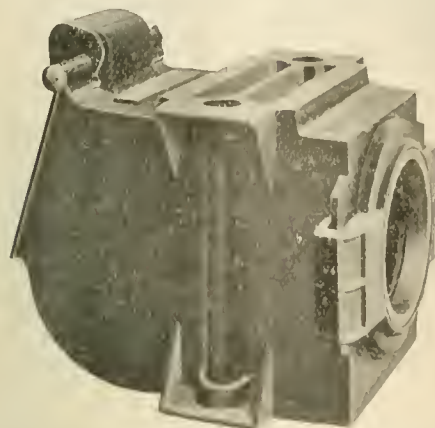

All Metal. Dust Proof. Oil Tight.
Chicago **McCord & Company** New York
WITH THE ONLY DUST GUARD

CONTENTS.

	PAGE.
Air Brake Department	317
Convention, Air Brake.....	317
*Valve, New York Duplex Brake.....	319
Car Brass, Lugs on M. C. B.....	308
Car Building Tricks in.....	310
*Cars, Pressed Steel.....	326
*Diaphragms, Car Vestibule.....	335
Editorial	312
Foremen, Round House, of 1904.....	313
Headlights, Electric.....	314
Motion, Third Law of.....	314
Piston, Explosion of a.....	314
Progress, Watching Scientific.....	312
*Education, Technical, in Russia, by L. Lodian.....	298
Explosion of a Piston	314
Foremen, Round House.....	336
Foremen, Round House, of 1904.....	313
General Correspondence.....	305
Car Brass, Lugs on M. C. B.....	308
Grade Crossings.....	310
Locomotives, Early, in Michigan.....	305
" Saxon ".....	310
Shop Management	308
Headlights, Electric.....	314
Heating Surface, Value of.....	298
Horse Power	297
Knowledge and Skill.....	310
Law, Third, of Motion.....	314
*Locomotive:—	
Growth of the, by Augus Sinclair.....	322
Consolidation for C. B. & Q.....	327
Consolidation for C. St. P. & M.....	325
Locomotives:—	
Early, in Michigan.....	305
" Saxon ".....	310
Motion, Third Law of	314
Personals.....	329
Piston, Explosion of a.....	314
Progress, Watching Scientific.....	312
Pump, High Speed Motor Driver.....	326
Questions Answered.....	315
Round House Foremen.....	336
Round House Foremen of 1904.....	313
Round Houses, Vreeland, H. H., on Electric.....	228
*Shop Appliances:—	
Foundry Ladle.....	308
Frame Repairer.....	332
Keyway Cutter.....	316
Right-angled Drill.....	316
Steel Tire Flange Gauge.....	309
Woodchopper.....	333
Shop Management.....	308
Signal, Railroad Cab.....	307
Stories and Narratives:—	
How a Bolt Machine Seller Sold a Machine and Bolted, by A. O. Brookside.....	307
Old Time Railroad Reminiscences, by J. S. Kidder.....	301
*Valve Gauge, Inspirator.....	306

section and the perspective drawing. Each part is numbered. Any one could order material from one of these charts with the greatest ease, and there is no mistaking the part designated. This catalogue will be sent free to any one who will write to the company for a copy of it.

The Hendrick Manufacturing Company, of Carbondale, Pa., one of the largest manufacturers of perforated sheet metals in this country, have opened an office in New York. It is in the Singer Building, 149 Broadway, corner of Liberty street. Mr. C. J. Thompson, who has had a broad experience along mechanical lines, will be the resident manager and will furnish estimates and quotations on short notice.

Contradicting the suggestion of a slackening of business activities comes the report from the Imperial Pneumatic Tool Department of the Rand Drill Co. telling of the large increase of sales since the first of the year. That the sterling worth of their products is universally appreciated is proved by the orders received for piston air drills, wood-boring machines and hammers and the installation of a number of complete pneumatic tool plants in the railroad shops, shipyards, boiler works, foundries and bridge and iron works both in this and foreign countries.

The Davis Calyx Drill Company, of New York, has just opened an office in the Johnston Building, Cincinnati, O., in charge of Mr. John F. Munn. Drills sold in West Virginia and Tennessee have demonstrated the suitability of the Davis Calyx Drills for penetrating the conglomerate of those States. Drilling is being done on property of Plumb Orchard Land Company, on Paint creek, Fayette county, West Virginia, and at Pack branch, nearby, for the same company; also at Herbert, Bledsoe county, Tennessee, for the estate of Joseph J. Kittel.

The East Rands Proprietary Mines Ltd., of South Africa, have just bought a complete Allis-Chalmers Wet Grinding Tube Mill. The Electrical Development Co., of Canada, have just purchased from the Allis-Chalmers Co., a 12 ins. by 16 ins. Self Contained Throttling Engine, a No. 5 Gates Breaker, a No. 5 "B" Elevator 51 ft. 6 ins. between centers, and other new machinery. The Allis-Chalmers Co., have sold to Thos. Phee, one of its complete No. 5 Railway Portable Crushing Plants, including the 80,000 pounds capacity car which is to carry it. Jno. & C. W. Ryan, Ohio, have purchased a No. 4 "D" Gates Crusher. Knox, Schlapp & Co., Ltd., Australia, have

purchased a No. 3 "D" Gates Breaker complete, and The Atlas Portland Cement Co., of Missouri, has purchased three 5 ft. by 22 ft. Tube Mills from the Allis-Chalmers Co.

The word "Bouquets" is the significant title of a unique folder just issued by the Bickford Drill and Tool Company, of Cincinnati, Ohio. It consists of a grouping together of the facsimile reproductions of a number of testimonials received from users of the "New Bickford Radial." The letters deal with specific results obtained by those who have Bickford radial drills and are therefore not merely the expression of friendly appreciation, but are of value because they are practically recommendations of the machine tool in question, given by people who know what they are talking about. If you like bouquets, even if they are thrown to another, or if you want to know something about the New Bickford Radial, or other of their machine tools, write to the company and they will send you the folder or give you any other information you may desire.

Handy Tool for Engineers and Automobileists.

Annexed engraving illustrates a wonderfully convenient small combination tool, which every locomotive engineer ought to have in his tool box. Besides being efficient nippers, the tool can be

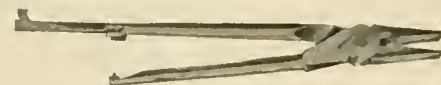

used as a wire cutter, screw driver, glass cutter, packing hook and burner grip. Its possession would prove a full tool box to automobileists. It has been put upon the market by Williams, Frost & Co., Winona, Minn.

Even the Squeal of a Pig.

As evidence of the truth in the humorous saying that Armour & Co. save even the squeal of a pig, is the fact that they dry the blood and use it for fertilizing purposes. The drying takes place in special kilns in which the steam hot blast apparatus is to be found. The drying by the fan system is positive, economical, efficient and always under absolute control and entirely independent of the atmospheric conditions. Armour & Co. recently placed an order with the B. F. Sturtevant Company, Boston, Mass., for a drying apparatus of this kind for their fertilizing plant at Kansas City, Mo.

In our April issue there is a description of the Hamilton Automatic Driver Brake Retainer written by Wm. Hamilton, the inventor. By a blunder the letter was signed S. B. Hamilton instead of Wm. Hamilton.

GRINDING MACHINE

For Grinding

Locomotive Piston Rods with Heads On!

GRINDS VALVE STEMS, CRANK PINS, ETC.
Will Re-Grind a Rod in ONE-SIXTH TIME Required to Re-turn.

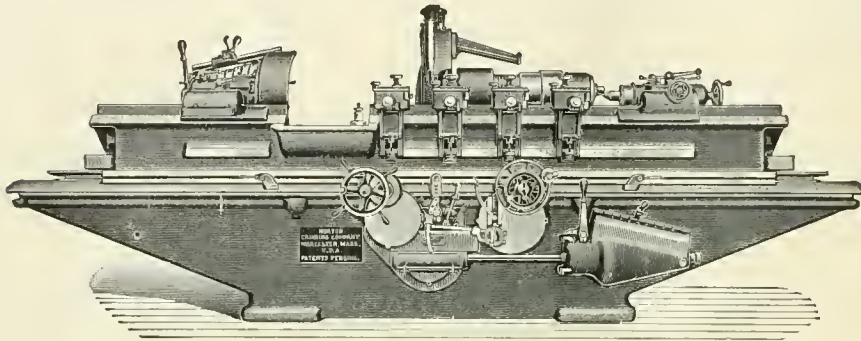

LIFE OF ROD DOUBLED

Because it is reduced in diameter only one-half as much by Grinding as by Turning.

GRINDING PRODUCES

A Round, Straight Rod, Uniform in Diameter, Free from "High Spots," and wearing longer before repairs are necessary.

WEAR AND TEAR ON PACKING REDUCED TO A MINIMUM.

Send for our Catalog and Further Particulars.

NORTON GRINDING COMPANY, Worcester, Mass., U. S. A.

New York Office: 114 Liberty Street.
HENRY F. FREVERT, Mgr.

London—LUDW., LOEWE & CO., Ltd.—Berlin
European Agents

INDEX TO ADVERTISEMENTS.

	PAGE.		PAGE.
Acme Machinery Co.....	Front Cover	Damascus Bronze Co.....	18
Acme White Lead and Color Works.....	6	Dart Mfg. Co.....	5
Ajax Metal Co.....	4th Cover	Davis, John, Co.....	16
Allis-Chalmers Co.....	—	Detroit Lubricator Co.....	18
American Balance Valve Co.....	4th Cover	Dixon, Joseph, Crucible Co.....	332
American Brake Shoe Co.....	8	Duff Mfg. Co.....	340
American Loco. Sander Co.....	339	Eynon-Evans Co.....	19
American Locomotive Co.....	23 & 1a	Falls Hollow Staybolt Co.....	10
American School of Correspondence.....	—	Fay & Egan Co., J. A.....	23
American Steam Gauge & Valve Mfg. Co.....	10	Flanders, L. B., Machine Works.....	8
American Steam Packing Co.....	15	Flannery Bolt Co.....	15
American Steel Foundries.....	4	Franklin Mfg. Co.....	5
American Valve & Meter Co.....	338	Galena Signal Oil Co.....	5
Armstrong Bros. Tool Co.....	2d Cover	General Electric Co.....	17
Ashteroft Mfg. Co.....	25	Gold Car Heating Co.....	—
Ashton Valve Co.....	339	Goodrich Rubber Co.....	15
Automobile Magazine.....	6	Gould Coupler Co.....	13
Baker, Wm. C.....	2	Gould & Eberhardt.....	4th Cover
Baldwin Locomotive Works.....	24	Griffin & Winters.....	339
Ball, Webb C. Watch Co.....	337	Hammett, H. G.....	4th Cover
Barnett G. & H., Co.....	2d Cover	Hancock Inspirator Co.....	11
Becker-Brainard Milling Mch. Co.....	—	Handy Car Equipment Co.....	336
Bettendorf Axle Co.....	3d Cover	Hayden & Derby Mfg. Co.....	—
Big Four Railroad.....	19	Hendrick Mfg. Co.....	10
Books:	—	Henry, N. W., & Co.....	—
Compound Locomotives.....	—	Hicks, F. M.....	4th Cover
Computers.....	—	Hoffman, Geo. W.....	10
Firing Locomotives.....	4th Cover	Hunt, Robert W., & Co.....	340
Handling Locomotives.....	—	Illinois Central R. R.....	10
Locomotive Running and Management.....	19	International Correspondence Schools.....	17
Miscellaneous.....	14	Jenkins Bros.....	4th Cover
Oil Burning in Locomotives.....	4	Jones & Lamson Machine Co.....	340
The American Locomotive.....	4	Kennicott Water Softener Co.....	7
Twentieth Century Locomotives.....	9	Lackawanna R. R.....	25
Boston & Albany R. R.....	16	Laidlaw-Dunn-Gordon Co.....	338
Boston & Maine R. R.....	19	Lake Shore R. R.....	19
Brady Brass Co.....	8	Latrobe Steel Co.....	25
Buker & Carr Mfg. Co.....	4	Latrobe Steel & Coupler Co.....	—
Carpenter, The J. M. Tap & Die Co.....	16	Lawson Car Co.....	26
Central R. R. of New Jersey.....	19	Link Model.....	12
Chapman Jack Co.....	2d Cover	Locomotive Chart.....	4
Chicago & Alton R. R.....	16	Locomotive Firemen's Magazine.....	21
Cleveland City Forge & Iron Co.....	4th Cover	Locomotive Publishing Co., Ltd.....	9
Cleveland Punch & Shear Works Co.....	15	Lodge & Shipley Machine Tool Co.....	13
Cleveland Twist Drill Co.....	4th Cover	Lucky Locomotive Stoker Co.....	—
Commonwealth Steel Co.....	20	McCormay & Torley Co.....	18
Consolidated Railway Electric Lighting & Equipment Co.....	25	McCord & Co.....	341
Consolidated Safety Valve Co.....	—	Manning, Maxwell & Moore.....	—
Crandall Packing Co.....	334	Middletown Car Works.....	5
Crane Co.....	7	Miller, Thornburgh & Co.....	1
Crosby Steam Gauge & Valve Co.....	24	Miner, W. H., Co.....	2d Cover
		Nathan Mfg. Co.....	10
		National Malleable Castings Co.....	4th Cover
		Nicholson, W. H., & Co.....	335
		Niles-Bement-Pond Co.....	—
		Niles Tool Co.....	3
		Norton Grinding Co.....	1
		Norwalk Iron Works.....	10
		Ozark Ginseng Co.....	337
		Pedrick & Ayer Co.....	—
		Peters, H. S.....	335
		Pittsburgh Crushed Steel Co.....	4th Cover
		Pond Machine Tool Co., The.....	—
		Porter, H. K., & Co.....	24
		Pratt & Whitney Co.....	—
		Pressed Steel Car Co.....	25
		Prosser, Thos., & Son.....	13
		Protectus, The.....	8
		Railway Appliances Co.....	337
		Railway Materials Co.....	2d Cover
		Rand Drill Co.....	15
		Revere Rubber Co.....	12
		Rogers Locomotive Works.....	24
		Ross Valve Co.....	4th Cover
		Rue Mfg. Co.....	19
		Safety Car Heating & Lighting Co.....	16
		Saunders, D., Sons.....	10
		Seaboard Steel Casting Co.....	15
		Sellers, Wm., & Co., Inc.....	6
		Shaw Electric Crane Co.....	—
		Sligo Iron & Steel Co.....	—
		Smooth-on Mfg. Co.....	19
		Southern Pacific R. R.....	5 & 13
		Standard Car Truck Co.....	16
		Standard Coupler Co.....	8
		Standard Paint Co.....	—
		Standard Steel Works.....	19
		Standard Tool Co.....	—
		Stannard & White.....	338
		Star Brass Mfg. Co.....	—
		Starrett Co., L. S.....	17
		Sturtevant, B. F., Co.....	3
		Tabor Mfg. Co.....	336
		Underwood, H. B., & Co.....	8
		Union Pacific R. R.....	9 & 334
		Union Switch & Signal Co.....	340
		United States Metallic Packing Co.....	18
		Utica Steam Gauge Co.....	—
		Valve Model.....	7
		Vitrified Wheel Co.....	4th Cover
		Wachter Mfg. Co.....	333
		Walworth Mfg. Co.....	2d Cover
		Watson-Stillman Co.....	4th Cover
		Westinghouse Air-Brake Co.....	22
		Westinghouse Electric & Mfg. Co.....	23
		Whittlesey, Geo. P.....	4th Cover
		Williams, Frost & Co.....	339
		Wood, R. D., & Co.....	2d Cover

Railway and Locomotive Engineering

Copyright by Angus Sinclair Co.—1904

A Practical Journal of Railway Motive Power and Rolling Stock

Vol. XVII.

174 Broadway, New York, August, 1904

No. 8

A 4-4-2 High Speed Machine on the Pennsylvania Lines.

The Atlantic or 4-4-2 type of engine here illustrated, and of which we have a large transparency with parts numbered and named, is one of a series which was built at the Schenectady shops of the American Locomotive Company for the Pennsylvania lines west of Pittsburgh. It is used on heavy fast passenger work.

The engine is simple, with cylinders $20\frac{1}{2} \times 26$ ins. The calculated tractive effort is 23,800 lbs. and the ratio existing

between tractive power and adhesive weight is as 1 is to 4.66, which means that for every pound of draw bars pull, which the engine can exert there are a little over four and six-tenths pounds resting on the driving wheels.

The engine here illustrated was fitted with inside admission piston valves, actuated by directed connection valve gear, the transmission bar being carried over the forward driving axle to the inside arm of the rocker, both arms of which hang down. The valve rod has a slotted crosshead like a Scotch yoke, in which

wheels at the rear have inside journals, there is no jog or splice in the frame at the back. The springs are overhung, with the exception of the carrying wheel spring, which is placed under the frame and behind the rear wheel. The drivers and the carrying wheels are all equalized together.

The carrying wheels are 50 ins. in diameter, the drivers are 80 ins. and the engine truck wheels are 36 ins. in diameter. The driving tires are held on by shrinkage as is usual, and also by what is

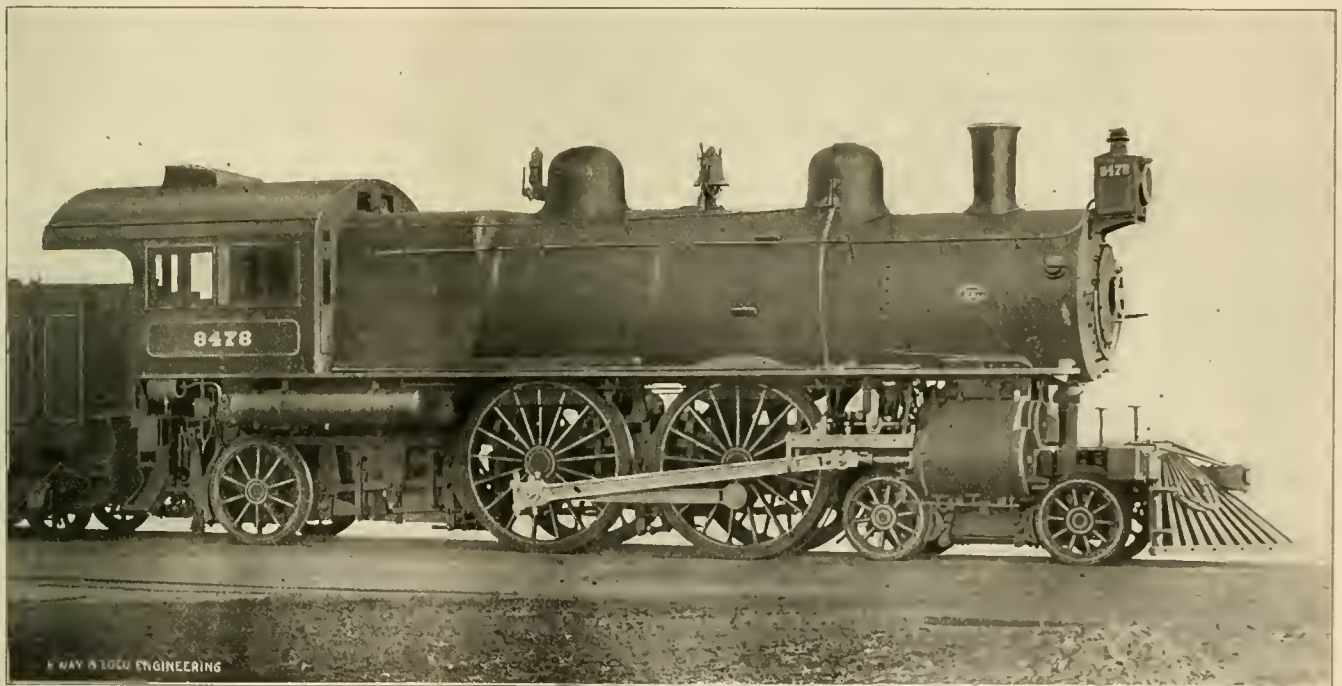

A TYPICAL ATLANTIC OR 4-4-2 ENGINE ON THE PENNSYLVANIA LINES.

between tractive power and adhesive weight is as 1 is to 4.66, which means that for every pound of draw bars pull, which the engine can exert there are a little over four and six-tenths pounds resting on the driving wheels.

The weight of the engine in working order is 178,000 lbs. The drivers carry 111,000 lbs., which leaves 67,000 lbs., which is divided between the front truck and the pair of carrying wheels at the back. The weight of the engine and tender in working order is 311,100 lbs. The total wheel base of the engine is 30

ft. $9\frac{1}{2}$ ins. and the driving wheel base is almost as short as it can be with 80 in. driving wheels, it is only 7 ft. 5 ins. long. The wheel base of the engine and tender is 60 ft. $2\frac{7}{16}$ ins. The valves are set line and line in full forward gear and $\frac{7}{8}$ in. overlap in full back gear. The valve has $\frac{1}{4}$ in. lead at 6 in. cut off. The engines of this class which are fitted with the ordinary D-slide valve have $1\frac{3}{8}$ ins. outside lap, $\frac{3}{8}$ in. inside clearance and are set with $\frac{1}{8}$ in. lead in full gear, forward and back.

The frames are made of hammered iron and are jointed in front. Each frame is made in two pieces, and as the carrying

known as the Gibson fastening. The driving journals are $9\frac{1}{2} \times 13$ ins., and those of the engine truck are $5\frac{1}{2} \times 10$ ins. The carrying wheel journals are 7×12 ins. The main and side rods are of I-section, and the butt end of the connecting rod is forked and the brass is held in by a bolted block and a key something like the design often used in marine work. The main crank pin bearing is $6 \times 6\frac{1}{2}$ ins., and the driving side rod bearing is $7\frac{3}{4} \times 5$ ins. The leading side rod bearing is $5\frac{1}{2} \times 4\frac{1}{2}$ ins.

The trailing truck is radial and is laid

out on a radius of 100 ins. in front of the axle of the carrying wheels. The brake hanger is arranged so that the brake shoes may follow the movement of the wheels. This is done by allowing for the cross swinging of the hangers at the suspension point, as well as for the ordinary fore and aft movement provided by a pin joint.

The boiler is 67 ins. outside diameter at the smoke box end, and the taper

The boiler is supplied by two No. 11 Simplex injectors and the hose connection or goose neck on the tender is so designed that the strainers can be readily got at, examined and cleaned. A fire connection can also be attached. The tank holds 7,000 U. S. gallons of water and carries 10 tons of coal. In this design of boiler the roof and crown sheets are level and enclose a steam and water space of about 24 ins. The center

is practically the same as the 4-4-2 engine here illustrated. A measured mile of level track was fitted with electric recording apparatus and circuit breakers placed a known distance apart. The speed made was thus accurately ascertained. With eight coaches a speed of 80 miles per hour was easily reached. The fastest speed attained was something less than 90 miles an hour, and the light engine itself pushed her speed up to 95.1 miles per hour.

The consumption of water at high speeds is always very great. On these brake tests a No. 10 injector was worked at full capacity, and another No. 10 was worked at about half capacity. The engine which we show here has two No. 11 injectors, and one of these injectors under ordinary conditions is capable of delivering over 5,000 gallons of water per hour, which is at the rate of more than 83 gallons per minute. It is not improbable that the brake test engine consumed water at the rate of about 125 gallons per minute without much alteration in the water level. A cubic foot of water contains 7.48 gallons, and

at that rate something over 16 cubic feet of water were put into the boiler every minute and turned into steam under a pressure of 205 lbs. The weight of the water thus injected was more than 1,000 lbs. An ordinary bath tub in a house when filled almost to overflowing contains about 10 cb. ft. of water. This engine took the contents of about one and a half of such baths every minute.

The engine is a good typical example of well designed and well proportioned modern high speed passenger power, with large boiler capacity.

The lines upon which it is built are symmetrical and the whole machine has the appearance of being powerful and swift. A few of the principal dimensions are as follows:

Gauge of road, 4 ft. 9 ins.; fuel, bituminous coal weight in working order, 175,000 lbs.; actual weight on drivers, 111,000 lbs.; weight engine and tender in working order, 311,100 lbs.

Cylinders—Dia. and stroke, 20½ x 26 ins.; horizontal thickness of piston, 5 ins.; dia. of piston rod, 3½ ins.; dia. of engine truck wheels, 36 ins.

Boiler—Working pressure, 205 lbs.; thickness of plates in barrels and outside of fire box, 1, 1½, ½, ¾, ¾, 1, 1½ in.; horizontal seams, butt joint quadruple riveted; circumferential seams, double riveted; fire box, length, 111 ins.; width, 72 ins.; depth, front, 67½ ins.; back, 64½ ins.; fire box plates, thickness, sides, ½ in.; back, ¾ in.; crown, ¾ in.; tube sheet, ½ in.; fire box water space, 4 in. front; 4 in. sides; 3½ in. back, tubes, material, national iron; No. 11, B. W. G.

Tender—Style, water bottom; weight, empty 56,150 lbs.; wheels, dia., 36 ins.; journals, 5½ x 10 ins.; wheel base, 20 ft. 6 ins.; tender frame, 10 in. steel channels; water capacity, 7,000 U. S. gallons; coal capacity, 10 tons; brake American on all drivers, trailer and eng. truck, oper. by air with Westinghouse high speed attachments; W. A. B. on tender and for train; 9½ in. pump on L. H. side; Westinghouse engineer's air signal.

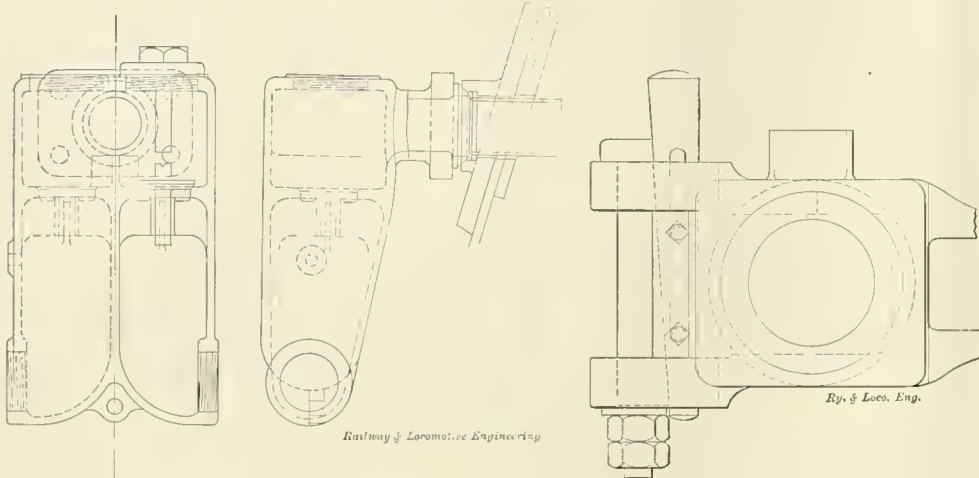

DOUBLE TOP CHECK ON BACK SHEET 4-4-2 PENNSYLVANIA LINES.

BUTT END OF MAIN ROD.

course is the first one. The outside diameter at the waist is 73 ins., and the length over all is 32 feet 4⅞ ins. The fire box is of the Belpaire type and is what may be called semi-wide, as it extends out over the frames, but does not reach the dimensions of a fire box designed for the burning of hard coal. The steam pressure carried is 205 lbs. to the square inch. The flues are ordinary 2 in. ones, but there are 315 of them, and

line of the boiler is 109 ins. above the top of the rail. Water supplied to the boiler enters through the check valves on the back sheet. The water from either injector passes through one 2½ in. iron pipe, which runs forward to within about 36 ins. of the front flue sheet or round head. This gives a certain amount of heat to the feed water before it mingles with the water already in the boiler. The top check valves and case are shown

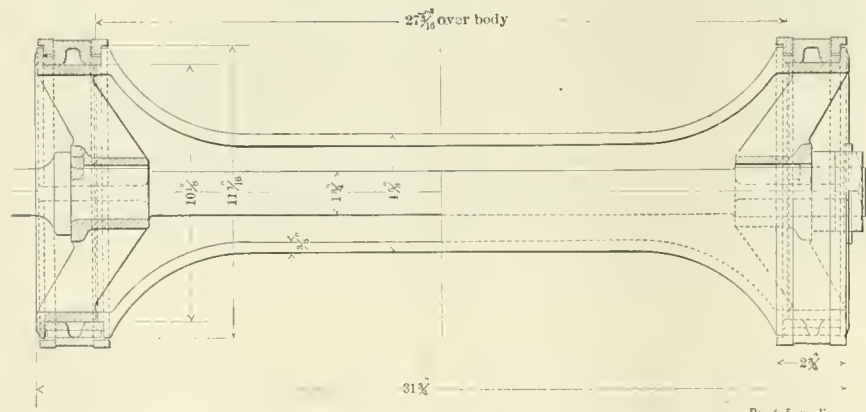

PISTON VALVES—INSIDE ADMISSION—4-4-2 PENNSYLVANIA LINES.

they are each 181 ins. long. The heating surface given by the tubes is 2,474 sq. ft. The fire box provides 165.7 sq. ft., which makes a total of 2,639.7 sq. ft. The grate area is 55½ sq. ft. There are two wash-out plugs in the bottom of the boiler, each 6 ins. in diameter. The forward one is placed so that its center is 27 ins. back of the front flue sheet and the one at the rear is about 24 ins. in front of the throat sheet.

in detail. The whole arrangement makes a very compact design, and the valves are easily got at for regrinding or repair.

The speed which can be attained by engines of this class is very well illustrated by the brake tests made last year on the New Jersey and Seashore division of the Pennsylvania. The runs were made over good track and the course was 28 miles long. An engine of the Pennsylvania E 2 type was used, which

Growth of the Locomotive.

BY ANGUS SINCLAIR.

(Continued from page 325.)

INTRODUCTION OF COAL BURNING.

The most important question occupying the attention of railway mechanical men during the fifth and six decades of last century, was the burning of bituminous coal in locomotive fire boxes. Most of the difficulties encountered originated in the fallacy that bituminous coal could not be burned in fire boxes designed for the combination of wood or coke without radical changes in design being carried out.

SMOKE PREVENTION DEMANDED.

The prejudice that existed among the mass of the people against railroads in the early days, led to the imposition of many embarrassing restrictions upon the companies, one of them being that the locomotives should burn coke or consume the smoke if bituminous coal was burned. That condition was imposed upon those who built engines for the Liverpool & Manchester Railway competition and for the locomotives operating all British railways. It was also imposed by the directors of the Baltimore & Ohio Railroad when they offered a prize of \$4,000 for the best native built locomotive.

PREJUDICE AGAINST COAL BURNING.

The burning of coal was by no means common in the United States fifty years ago, and there seems to have been strong prejudices against its use. Its smoke producing properties also raised prejudices against "sea coal" in Great Britain, for as late as 1850, D. K. Clark, the celebrated engineer, who was an exponent of scientific opinion, wrote: "Coal, at least of the ordinary bituminous kinds, ought not to be used as a staple fuel at all. It is the mere raw material of fuel—the ore from which coke is extracted, and contains some valuable compounds which, on the one hand, ought never to be thrown into the furnace, and on the other ought not to be wasted by the prevailing method of coking. At some time hence it will be difficult to believe that those hydrocarbons, some of which are in themselves so valuable, are actually burned off and lost in the process of coking. The more difficultly manageable of these compounds are obtainable from the coal at temperatures so low and so easily, and yet are so valuable from the oil alone, that the fact cannot fail much longer to attract spare capital and open up a new manufacture of which we cannot meanwhile guess the extent. Ultimately green bituminous coal will be entirely abandoned as the staple fuel for either locomotives or any other class of boilers."

That was one of the prophecies that proves the sense of the saying, "Don't

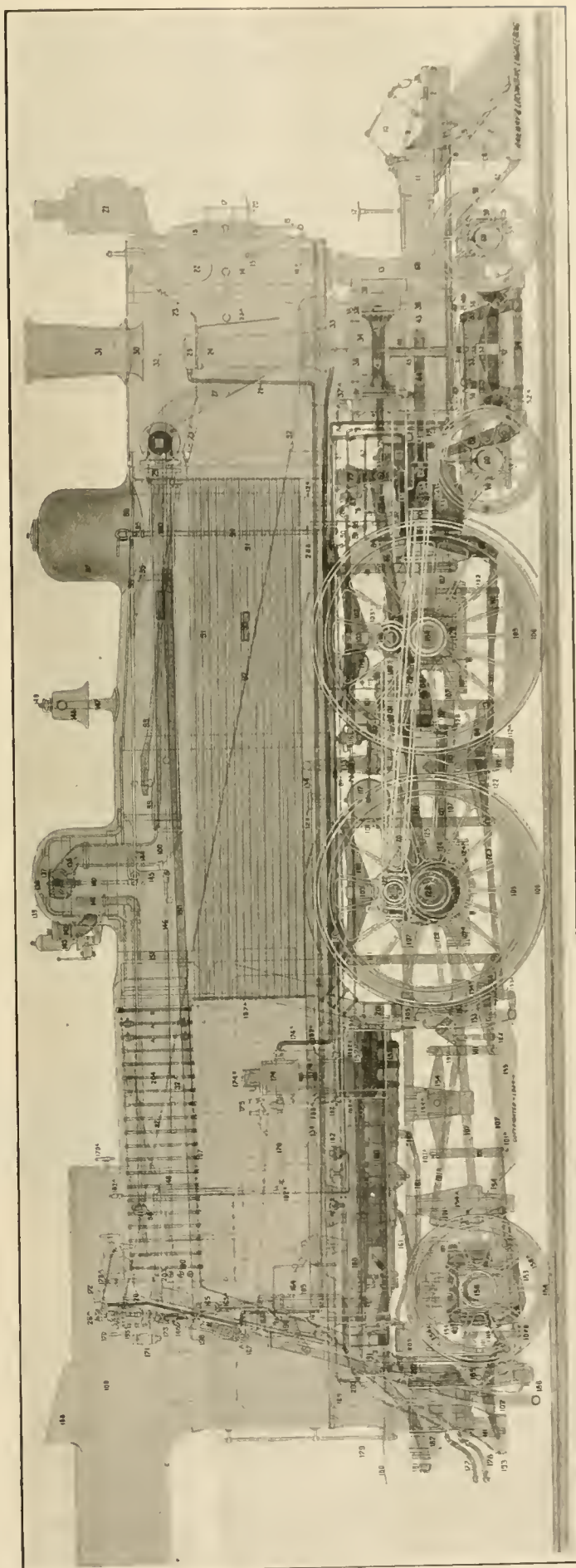

PENNSYLVANIA RAILROAD EXPRESS ATLANTIC TYPE LOCOMOTIVES. OUR EDUCATIONAL CHART NO. 7. NAMES OF PARTS ON PAGE 362.

prophesy unless you know," but the sentiment was popular in the scientific world at the time it was written.

Owing to the restrictions concerning the smoke nuisance the railway companies in Europe inaugurated the operation of their locomotives by burning coke. Although Cooper's "Tom Thumb," the first native built locomotive of the United States, burned anthracite coal, nearly all its early successors burned wood, which was the popular fuel of the country.

tude of inventors of coal burning locomotive boilers came into the field, and they all insisted that the use of their boiler was the only way that railroad companies might expect to profit from the use of cheap fuel.

THE BEATTIE BOILER.

The teaching of scientific pretenders, and the claims made by people interested in special forms of so-called coal burning boilers, led to the invention of a multitude of complex fire boxes of which the Beattie furnace, illustrated in Fig. 53,

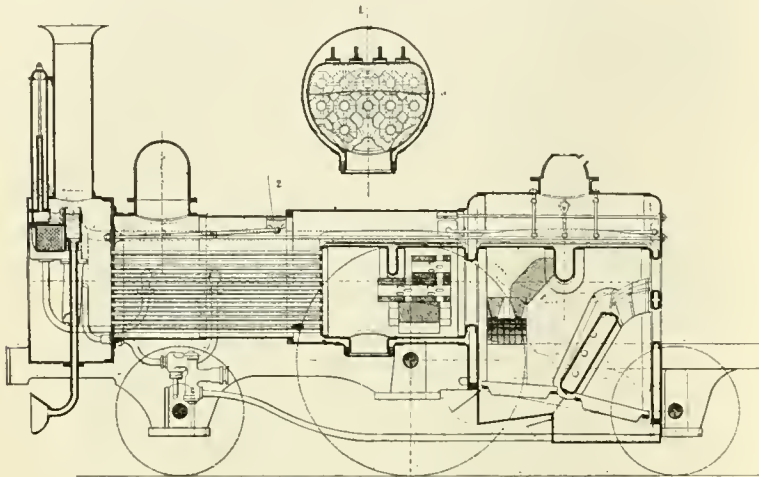

BEATTIE'S SMOKE PREVENTING BOILER. FIG. 53.

CALL FOR REDUCTION OF FUEL BILLS.

For the first ten years of railway history, the cost of fuel for operating locomotives received little consideration, because those in charge of the motive power devoted their attention principally to the developing of an engine that could be depended upon to haul trains punctually without failures of any kind. When this had been accomplished, the inevitable question of fuel economy came into prominence. European engineers were compelled to work out the problem of substituting bituminous coal for the expensive coke, which had lost a large proportion of heat producing elements of the coal in the process of making. Wood soon began to be expensive in those portions of the United States where railroads were most numerous, and railway master mechanics were compelled to devote themselves to the work of adapting the locomotives to the combustion of coal.

INFLUENCES THAT OPPOSED COMMON SENSE FIRE BOXES.

There were two influences which combined to render the task of adapting the locomotives in use to the combustion of coal extremely difficult and erected obstacles that were largely imaginary. Scientific writers, whose councils were accorded to be of the utmost importance, insisted that air should be thoroughly mixed with the fuel gases, and a journey as long as possible given to the products of combustion before they entered the tubes. On the other hand a multi-

was for a time considered the nearest approach to sound scientific principles. In this invention the fire box was divided transversely into two compartments by the inclined water space. The two compartments had each separate grates, fire doors, ash pans and dampers. A combustion chamber extended into the barrel of the boiler with a man hole and cover. From this chamber extended the tubes, as in ordinary boilers, but they were unusually small and short. A hanging bridge extended from

there was a faggot of fire brick tubes. The doors had each 200 $\frac{3}{8}$ -inch holes for the admission of air.

A great many locomotives belonging to the London & South Western Railway, of which Joseph Beattie was locomotive superintendent, were equipped with his coal burning furnace between the years 1854 and 1859, and it was said to be a perfect smoke preventer *when firing was carefully performed*. It is, however, inconceivable that such an elaborate system of gas mixers could be operated except under the influence and supervision of the inventor. Of course, every person familiar with the introduction of inventions pretended to improve railroad machinery know, that many worthless or even ridiculous things are made for a time successful when some influential personage is interested, as in the case of the Webb three cylinder compound locomotive; but the test of time passes only things that are fit for their purpose.

Incidentally it may be noted by students of locomotive engineering that Beattie's locomotive comprehended several appliances that have been at various times the object of patents in the United States. Conspicuous among these are the feed water heater and the funnel for operating an air ejector in the smoke box.

ELEMENTS USED IN BEATTIE BOILER.

Beattie's furnace had no new feature even for that early day, but it comprised a variety of inventions which were supposed to constitute a superb combination. The split bridge was invented by Josiah Parker in 1820 and was elaborated about twenty years later by C. Wye Williams, the celebrated apostle of smoke prevention. The water bridge was first applied to a steam boat boiler fire box by Robert L. Stevens, of Hoboken,

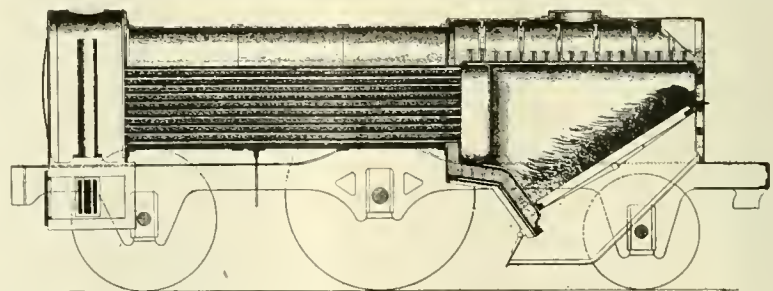

CUDWORTH'S COAL BURNING BOILER. FIG. 54.

the crown sheet of the fire box and another from the roof of the combustion chamber. A grating of fire bricks spanned across from the top of the water space to the back of the furnace between the two doors. An arch of fire brick segments was sprung across in front of the combustion chamber. From the top of this arch another set of fire brick reached up to the side of the hanging bridge. In the combustion chamber

in 1837. The combustion chamber was patented in England by Stubbs & Gryll in 1846, and perforated openings for admitting air above the fire were employed long before the days of locomotives. The patentees of the combustion chamber did not apply the invention to a boiler, and as far as I can learn that was first done in 1851 by A. F. Smith, master mechanic of the Cumberland Valley Railroad.

INVENTORS OF SMOKE PREVENTING FIRE BOXES.

In Great Britain, nearly every locomotive superintendent became the inventor of a smoke consuming fire box, and the best known patterns are here illustrated. The Clark jet arrangement, with openings through the walls of the fire box through which currents of air were induced by steam jets, became the most popular form of smoke preventer, and was used long after the more elaborate

The invention was first applied as a shelf, straight across the fire box, and consisted partly of fire brick and partly of iron. The second one applied was of common fire brick, 2x4x8 ins. each, forming an arch and supported by angle irons bolted to the side sheets.

The third arch was composed of four curved blocks of fire brick 12 ins. wide, forming an arch which was supported on T-bolts which were screwed into the side sheets. The changes followed in

required by the progress of the times. By the time the demand for coal burning arose; most American railroad companies had adopted the practice of depending upon locomotive building firms for their supply of motive power, and these builders were expected to provide the improvements demanded by advances in engineering science or practice. On this account few master mechanics of the United States were designers of coal burning appliances, Griggs, Head, Yates, Millholland, Hayes, Buchanan and Eaton of the Great Western of Canada being notable exceptions.

DESIGNING SMOKE PREVENTING FIRE BOXES.

In a general way the problem which the coal burning furnace inventors en-

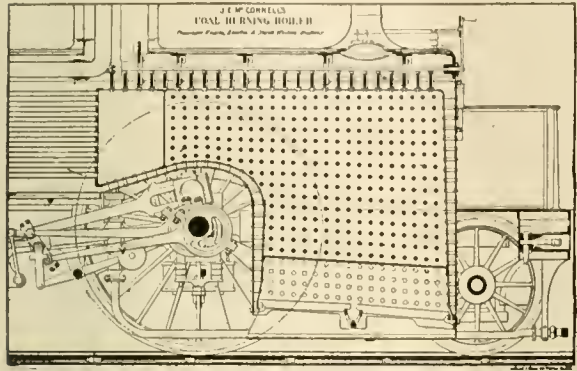

McCONNELL'S COAL BURNING FIRE BOX. FIG. 55.



JEFFREY'S COAL BURNING STEP GRATES. FIG. 63.



devices were abandoned. Before Clark designed the jets for supplying air to the surface of the fire, several inventions had been tried for whitening the smoke by steam forced into the fire box; but, being based upon ignorance of the principles of combustion, they were little used.

GRIGGS APPLIES THE BRICK ARCH.

The pioneer of the United States in the introduction of a smoke preventing fire box was George S. Griggs, of the Boston & Providence Railroad, who, in

quick succession and all the locomotives were changed to coal burners as fast as the work could be done.

The cost of wood fuel, the year previous to the introduction of coal, was 35 cents per train mile. The cost of coal during the year that followed the change was 8 cents per train mile.

The first coal burners had the old wood burning stack with a coarse netting. Next improvement was putting a cover on top with a circular opening 12 ins. diameter. Mr. Griggs soon decided that the large wood burning stack necessary for wood burning, even when modified was not satisfactory, so he designed

deavored to work out was supplying to the fire all the air necessary for complete combustion, mixing it with the fire gases and maintaining a furnace temperature sufficiently intense to prevent any portion from falling below the igniting temperature. These were conflicting conditions and efforts were made to overcome their difficulties by elaboration of furnace attachments. Water tables and mid feathers were for a time highly popular, but experience demonstrated that they took away so much heat from the gases, that loss of fuel ensued and smoke was caused by part of the fire box becoming chilled below the igniting temperature.

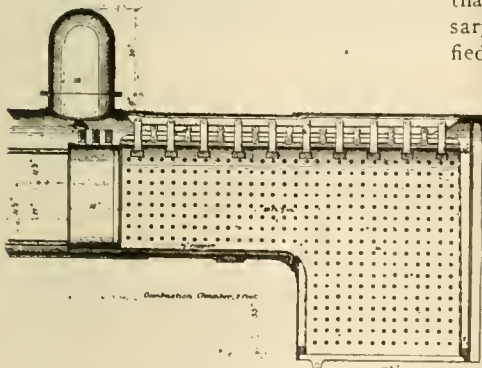
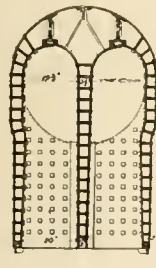

FIG. 56.



Section of Firebox
FIG. 57.

ANOTHER McCONNELL'S COAL BURNING BOILER.

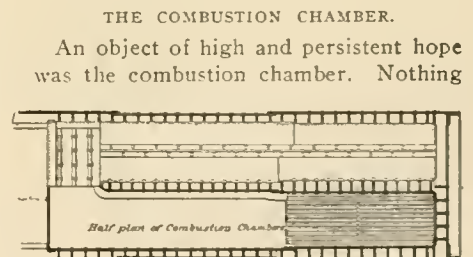

FIG. 58.

THE COMBUSTION CHAMBER.

An object of high and persistent hope was the combustion chamber. Nothing

1857, applied the brick arch, which is almost the only invention remaining in popular use out of the thousands of devices designed for the purpose of preventing smoke. George Richards, who was associated with Mr. Griggs when the fire brick arch was first applied and who succeeded Mr. Griggs as master mechanic, has given me the following information about the work of his chief.

Mr. Griggs changed a locomotive from a wood burner to a coal burner in 1857.

the diamond stack and it was applied in substantially its present form.

WORK OF AMERICAN MASTER MECHANICS.

The attitude of American railway master mechanics on the introduction of coal burning appliances was different from that of their compeers, the locomotive superintendents of Europe. The latter were their own engine builders and designers, and upon them devolved the responsibility of introducing the changes

seemed more susceptible of demonstration to the scientific mind than the theory that by prolonging the passage of the heat gases from the grates to the flue openings, increased opportunity must be given for the chemical combination that produces the highest development of heat. To meet this perfecting condition, all sorts and sizes of combustion chambers were devised. The favorite combustion chamber was open in direct connection with the fire box, but others

were near the middle of the boiler with large tubes that were not supposed to extinguish the flame intervening between the fire box and chamber. As the combustion chamber was the vessel where the final combination of oxygen with the hydro-carbons was to occur, inventors did not fail to provide a direct supply of air at that point. Strange as it may appear, and contrary to nature's laws as read by the ordinary observer, that source of air supply was never opened without reducing the steam generating

more, four feet could be cut off them with advantage and converted into a combustion chamber.

WORKERS ON THE COAL BURNING PROBLEM.

The illustrations which we publish of the leading British and American coal burning locomotives constitute a graphic history of the subject.

I have never seen a drawing or engraving of Grigg's invention, but it possessed no complex features, being a plain brick arch with means for permitting the admission of a limited supply of air above the fire through fire door perforations.

About the time that Griggs introduced

project the entering air upon the surface of the fire, has been one of the best combinations ever applied for the prevention of smoke and it is still in very successful use on thousands of locomotives. It is not known who first applied the baffle-plate, hood, or deflector as it is variously called, but it may be accepted as certain that some observing fireman first suggested its use. When a fireman would push the shovel upside down into the fire box, a common practice, to enable him to examine the surface of the fire, he would notice that smoke ceased passing out of the chimney so long as the inverted shovel was injecting air upon the surface of the fire. The

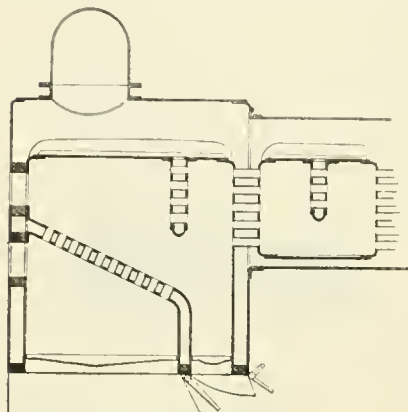

FIG. 59.

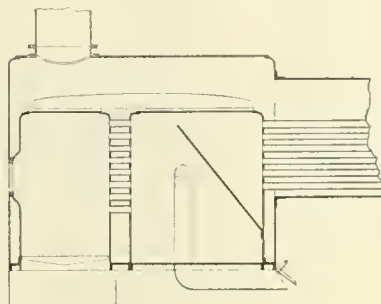

FIG. 60.

JOHN DEWRANCE'S FIRE BOXES.

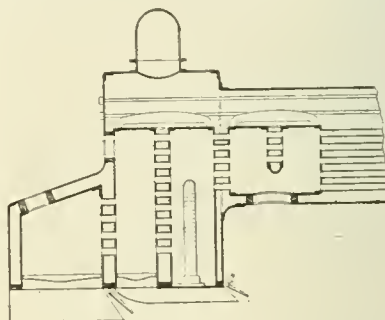

FIG. 61.

capacity of the boiler. Those operating locomotives so equipped soon learned that shortness of steam pressure quickly followed admitting air direct to the combustion chamber, so they left the openings in innocuous desuetude.

In spite of all the theories that complete combination of the gases would be promoted by the space provided in a combustion chamber, flue surface was never substituted for that space without producing an improvement in the steaming properties of the boiler.

the use of the brick arch, cast iron deflectors were tried by Samuel J. Hayes of the Illinois Central, W. S. Hudson of the Rogers Locomotive Works, H. Uhry of the New Jersey Locomotive Works, and others; but the life of cast iron exposed directly to the heat of a

man who first reasoned between cause and effect and proposed some sort of permanent scoop on the fire door originated a very valuable invention.

The pioneer coal burning fire box inventors provided a great variety of plans for the admission of air above the fire.

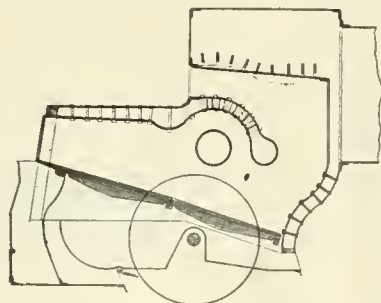

FIG. 62.

CRAIG'S COAL BURNING FIRE BOX.

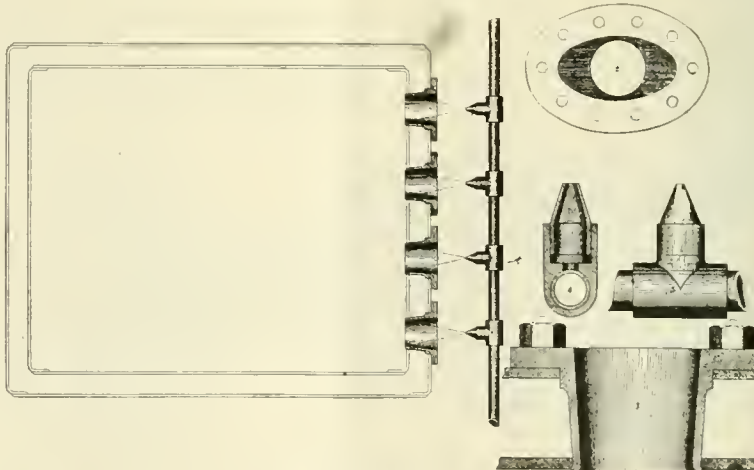

FIG. 64.

D. K. CLARK'S STEAM JETS.

It seems to me, however, that the development of the twentieth century locomotive, with short wide fire box and enormously long tubes, gives the opportunity for the introduction of a combustion chamber that would increase the efficiency of the boiler. In the old engines the combustion chamber made the tubes too short for efficiently absorbing the heat from the fuel gases. In boilers that now have tubes 20 feet long, or

fire box was short lived and the refractory fire brick came gradually into use. MEANS OF ADMITTING AIR ABOVE THE FIRE.

All through the earnest labor attending the efforts to produce a fire box that would burn coal rich in hydro-carbons without causing a nuisance from smoke, the fire door has been a favorite point for the admission of air and that connected with a baffle plate, designed to

One writer on smoke prevention advocated that 4,000 small holes be provided to admit air through the back walls of the fire box and his advice was followed in a modified form. Hollow stay bolts came largely into use and many fire boxes were so profusely perforated that the fiery furnace made a pyrotechnic display as trains rushed through space on dark nights.

(To be continued.)

Draw Bar Side Clearance.

Mr. G. H. Forsythe, speaking of the want of draw bar side clearance to the North-West Railway Club, put the matter in a nutshell when he said "the speaker does not believe that were any of you to attempt to pull a load, say with a chain, that you would permit an object to intervene which would deflect the force you were exerting upon the object to be pulled; but that, gentlemen, is practically you are insisting upon your locomotive doing, and to an aggravated extent, for there is a side deflecting load for each coupler draw bar in the train passing over a curved track."

In picturing a freight train approaching a curve where the cars have limited side clearance he showed that as soon as the draw bars have attained their limit of side movement they are subjected to lateral strains proportional to the force necessary to take up the lost motion between the car members and

be a clearance of about $3\frac{3}{4}$ ins. on each side.

Taking the draw bar pull, not as simply that required to move the car but as the mean of the successive draw bar pulls exerted upon the cars passing around the curve, he said that in passing around these ordinary curves with draw bar lateral movement limited, the pressure at the side guards amounts to a little more than 23 per cent. of the mean draw bar pull, while at the trucks the force will amount to over 32 per cent. If the draw bars were suddenly allowed to swing freely into the line of draft, the side pressure at the trucks would drop to about 16 per cent. When on a reverse curve the pressure on the side guards amounts to 48 per cent. of the mean draw bar pull with corresponding increase at the trucks.

The constrained position of the draw bars, meeting at an angle when the train is going around a curve, shows

Mogul for the St. Joseph & Grand Island Railway.

The Baldwin Locomotive Works, of Philadelphia, have recently supplied the St. Joseph & Grand Island Railway, of which Mr. F. T. Slayton is master mechanic, with some freight engines of the mogul or 2-6-0 type.

The engines are simple, with $19\frac{1}{2} \times 26$ in. cylinders and 58 in. driving wheels. The unique feature of these engines is the throttle rigging. As will be seen in our half tone illustration and more clearly in the line engraving, the throttle stem passes out through the dome cover and all the rods and connections are, therefore, easy to get at, and are always within reach. This arrangement was designed to obviate the trouble occasioned by the ordinary throttle rod becoming disconnected inside the boiler. All screw connections have been avoided and the stuffing box being in the dome cap causes any leak-

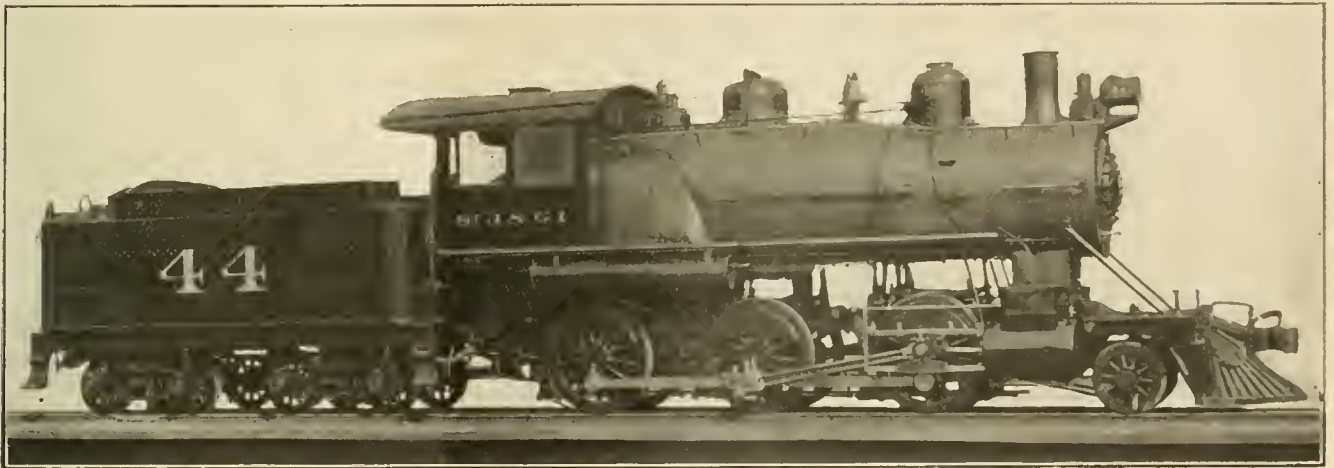

BALDWIN ENGINE FOR THE ST. JOSEPH & GRAND ISLAND RAILWAY.

trucks, such as the give and take between the bearings, etc.

The more serious stage is where the cars with members rigidly set, are bodily moved sideways by the straining draws bars until the wheel flanges are forced hard against the rails. Even supposing the side strains caused in this manner result in the breakage of a coupler only once in a while nevertheless there can be no difference of opinion as to the bad practice of allowing abnormal and destructive forces to exist if they do not always reach the breaking point.

Mr. Forsythe took for an example a train of freight cars, each 38 ft. 6 ins. long and equipped with the regular M. C. B. coupler and draw gear. As this train passes round a single curve, such as are common on main lines, each draw bar should be allowed at least 2 ins. clearance on each side. Let this train pass round a reverse curve of the same, or through a cross over track, and it will be found that there should

that a bending moment is induced and instead of the draw bars acting as links they become rigid; levers working sometimes to their own destruction but always to the disadvantage of the car members.

Old Time Railroad Pass.

Col. William Dorris, of Huntingdon, enjoys the rare distinction of traveling on a Pennsylvania railroad pass issued in 1850, which is without limit. This pass is a curiosity, having on it, in addition to the necessary wording, the picture of an engine and two cars, which are unique, as might be imagined. The engine is anything but modern, and the coaches have the old time "possum belly" in which baggage was carried. The Colonel retains this pass because he was one of the original stockholders of the company.

Work is progressing on the construction of locomotive building works in Kansas City, Mo. The specialty of the works will be gasolene motors.

age of steam which may occur to escape directly to the atmosphere and in doing so it cannot inconvenience the occupants of the cab. The throttle opens in the usual way, by the valve lifting. Steam enters from the top and is thus drawn from a region where the steam is dry. The valve being hollow, its interior, even when closed, is full of steam which keeps it at the same temperature as the throttle case and so avoids variations and leaks due to unequal expansion.

The driving wheels are all flanged and are all equally spaced. The pistons drive on the center pair, the axle of which carries the eccentrics. The valve motion is indirect, and the valve is of the ordinary D slide type, balanced.

The boiler is a wagon top with the gusset in the second course. The diameter at the smoke box end is 64 ins. and the working pressure is 210 lbs. The heating surface from the tubes is 2,225 sq. ft. and from the fire box 150 sq. ft., making a total of 2,375 sq. ft.

The grate area is 44 sq. ft. The tubes are 329 in number and are 2 ins. in diameter and 13 ft. long.

The tender tank, which is carried on a steel frame, has a water capacity of 6,000 U. S. gallons. A few of the principal dimensions are as follows:

Firebox—Length, 96 ins.; width, 66 ins.; depth, 67 ins.; depth, front, 67 ins.; back, 56 ins.; thickness of side sheets, back and crown, $\frac{3}{8}$ in.; tube sheet, $\frac{1}{2}$ in.; water space, front, sides and back, 4 ins.; tubes No. 11 B.W.G. Wheels—Main jour., 9 x 12 ins.; others 9 x 12 ins. Wheel Base—Driv., 15 ft. 0 in.; total eng., 23 ft. 2 ins.; eng. and tender, 50 ft. 2½ ins. Weight—On drivers, 135,660 lbs.; eng. truck, 21,860 lbs.; total eng., 157,520 lbs.; total eng. and tender, 278,000 lbs.

Paying Their "Weigh."

One of the most interesting innovations in railway management is that

by the number of pounds he weighs.—*The Tatler.*

If the road weighing passengers is, as we suppose, an electric one, we consider it little short of injustice to charge by weight for those who ride in a motor coach, because every pound added to the light weight of the car really increases its adhesive weight, and within reasonable limits, actually helps the car along just as if a man got out and pushed.

Weighing people who ride in cars as a means of determining what they should pay, is very wide of the mark. The idea which this company should adopt is to charge by inches of abdominal diameter. A neat sort of turnstile and gauging apparatus could be arranged so that the amount of seating

cific gravity and a footwarmer to restore his temperature, and the specific gravity could be used in the computation necessary to adjust the amount to be rightly charged for railway fare. Think what a pleasant and refreshing sight it would be, on a hot summer day, to see a carload of people bobbing around in a cool water tank, waiting for their train. The more we think it over the less we like the unscientific avoirdupois idea. The "space payment" or the specific gravity plan are the ones which should occupy the attention of all inventors, until this desirable reform is carried to victorious perfection.

Slow Trains of Spain.

Trains in Spain are certainly slow. A rate of ten or twelve miles an hour is considered a good average of speed for everyday travelers. When the Spanish officials wish to show visiting foreigners what they really can accomplish in the way of rapidity, they offer express trains which dash madly across the landscape at an average rate of fifteen or eighteen miles an hour. In one way this proves an advantage, for the traveler sees a great deal more scenery for his money than if he were rushed past it swiftly.

The Gordon Bennett Automobile Race.

Most of our readers are familiar with the amazing speed at which Mr. W. K. Vanderbilt, Jr., drove an automobile on the ocean beach of Florida during the races arranged by the *Automobile Magazine*. The velocity was close to one hundred miles an hour, being faster than any authenticated speed of a locomotive, but it was for only a short spurt, nevertheless it indicated the speed possibilities of automobiles and recent experiences prove that form of power vehicle to have wonderful speed capacity even for long distances.

Several years ago James Gordon Bennett, the well known publisher, presented a cup to be competed for annually by the automobilists of the leading European countries and of the United States. Germany won the cup last year and that entailed the competition this year to be held in that country. The contest was held in June and eighteen machines started, representing six countries. The course was 342 miles long, almost the distance between Chicago and Cleveland, and it was covered by a French car in 5 hours 50 minutes and 3 seconds, an average speed of 51.9 miles an hour. The average speed made over the course was astonishing, few of the contestants falling below forty miles an hour.

Out of the eighteen competitors to enter twelve went through the entire run. A report shows that France had

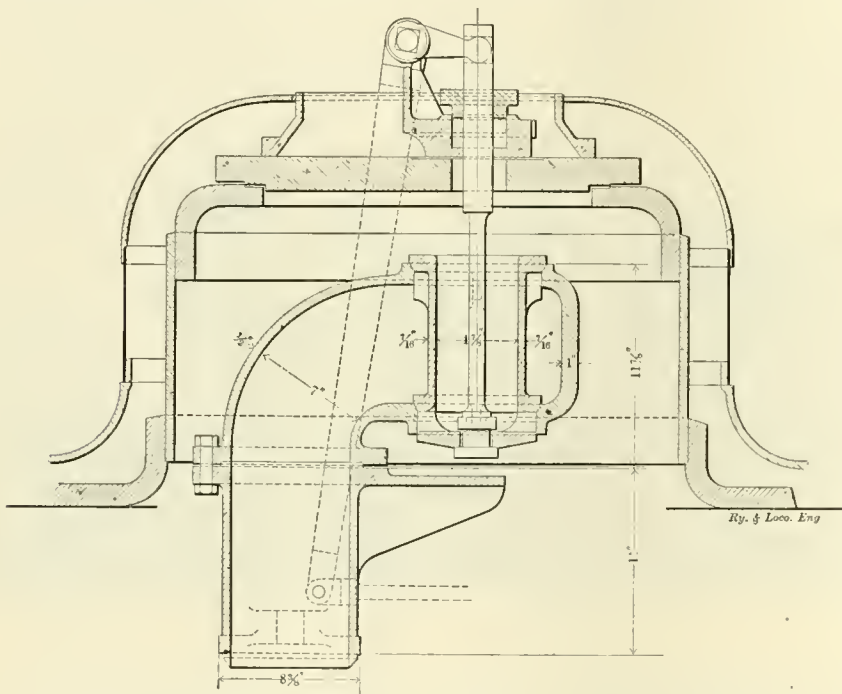

THROTTLE ARRANGEMENT OF THE ST. JOSEPH & GRAND ISLAND ENGINES.

adopted by the Rapid Transit Company in Colorado, where passengers are charged according to their weight. Every ounce that travels by this railway pays fare, whether it is an ounce of clothing or of human flesh and bone. The method of operation of this new system is rather difficult to picture, but it is easy to describe. The road is thirty miles long and has ten stations. At each station has been constructed a chute or passage through which each of the passengers will reach the ticket office. In this chute is a turnstile which registers the number of the passengers, and in that way checks the numbers of the tickets issued. At the end of the chute is a scale on which the passenger stands for a moment while his weight is being taken. In accordance with the weight registered by this scale a ticket is issued for an amount which is regulated

capacity taken up would bear some proportion to the price paid. A man can hold a valise on his knees and inconvenience no one in the car but himself, but a portly person, the width of two, cannot squeeze into the space provided for one without serious inconvenience to those around. A railroad company like an advertising man is a "space seller" and ought to provide a delicately adjusted caliper device, so as to get the "width of beam" of its patrons as they pass the ticket office.

If the weight idea is adhered to it should be logically worked out and the specific gravity idea introduced. This would necessitate the use of a tank filled with pure distilled water kept at a temperature of 39.2 F., in which the road's patrons could float for a few moments, before train time. Then each should receive a certified statement of his spe-

all three of her entrants in the list, getting first, fourth and seventh places, while Germany had two of its entries to finish, getting second and third places. Austria, Italy and England made the next best showings, in the order named, each having two of its three entries finish. The other car to cross the line was the Belgian Pipe, which got sixth place. Even Jarrott, who came in twelfth, took less than eight hours to cover the 342 miles of the course.

Signals and Signaling.

BY GEORGE SHERWOOD HODGINS.

(Continued from page 254.)

THE INTERLOCKED "DIAMOND" CROSSING.

The "Diamond," or grade crossing formed by the lines of two separate railways gives us an example of very

Proceeding along the northbound track the first signal met with is the distant, marked A. The signal at B gives a route indication. The top arm governing the high speed or the straight main line, while the lower arm indicates the diverging route. Moving along the southbound track the distant D comes first, the home E next. This home signal indicates the position of the switch at G as well as gives permission to go over the crossing. Dwarf signals are used on all tracks to give permission to a train to move in the reverse direction to the usual run of traffic, over the back-up derailing switch and over the crossing. Dwarf signals H, I, F and S indicate the position of the back-up derailing switches. The normal position of all the switches is open, breaking the lines; and all the signals are normally in the stop position.

diamond crossing with the intention of passing over it, the distant signal at A if in the proceed position, would indicate that the top arm on the route signal B had been lowered and that the switch at b had previously been set for the main line. These signals being so set, the train would be entitled to pass over the crossing. The sequence of operations performed by the signal man in providing for the passage of this train, was first to close the derailing switches at C and S. In doing so he locked the derailing points on the East & West Railway open. As the signals on the East & West Railway cannot be cleared until the derailing switches on that line have been closed the signals on the North & South Railway indirectly lock the East & West Line and prevent the signals for the two routes being cleared at the same time.

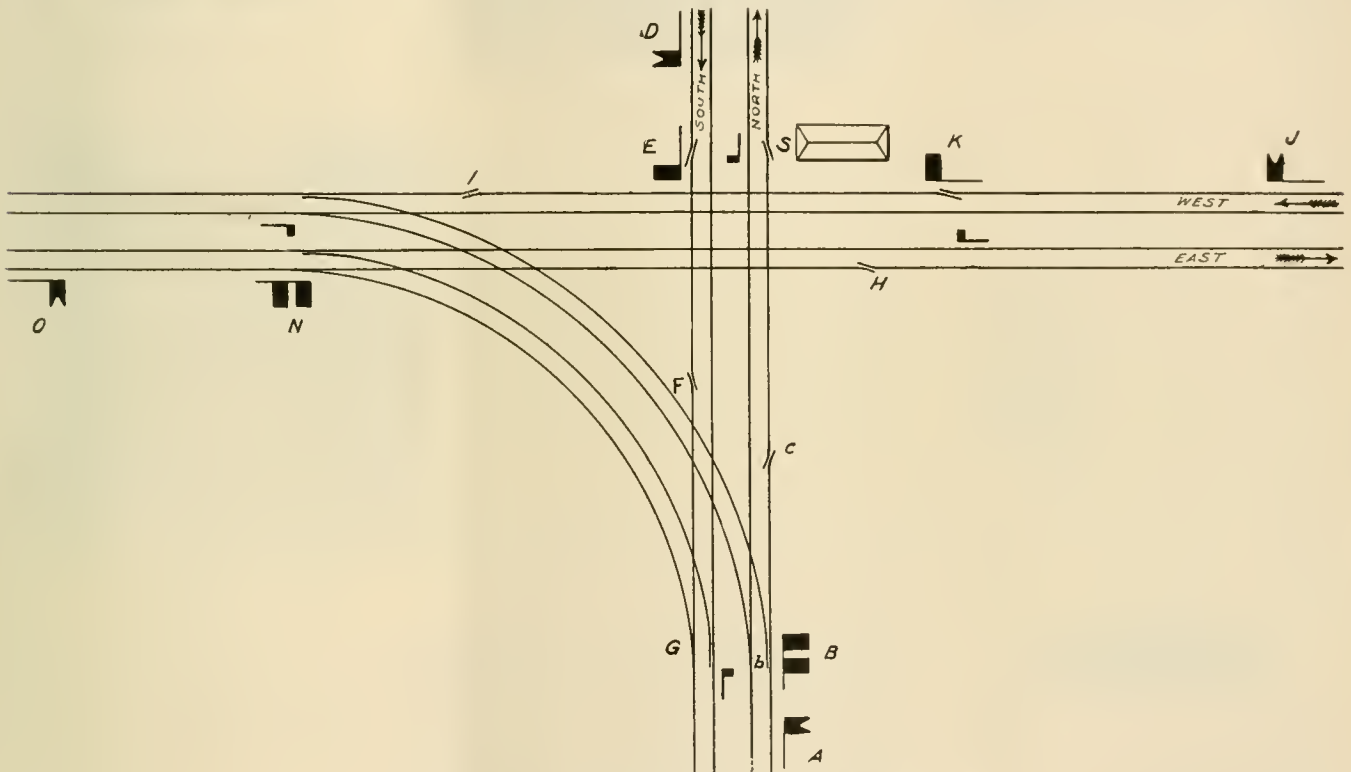

DIAGRAM OF TYPICAL LEVEL CROSSING AND JUNCTION POINT.

interesting and effective signaling. We have chosen what may be called a right angled crossing with connecting tracks between the main lines, and the signals and tower are shown in the accompanying diagram. Fig 1. The angle which the tracks make with one another are of no importance as far as the signaling of the crossing is concerned.

For sake of simplicity we will suppose that the tracks are provided with derailing switches that are arranged to check backing up as well as forward train movements, and all the signals and switches are worked from one interlocking tower.

One of the safety features of such an interlocking plant as we are describing is that any route may be "set" by the signal man, but it need not necessarily be indicated, though no two conflicting routes can be "set" at the same time. All the signals may be left in the stop position and trains approaching in any direction would be made to halt. That much the signal man can do, but the moment he attempts to indicate a route, there is only one route which he can show to be clear, and that is the route that has been "set."

In order to reduce this general statement to definite terms, suppose a northbound train was proceeding toward the

In thus guaranteeing a clear track to the northbound train he blocked all routes except a possible movement of a train from N to G, in which case the road from D to G would be blocked and would contain an open derailing switch at E; or if a movement from D to G had been provided for, it would be only when a movement from N to G had been blocked. When the northbound main line was "cleared," the only other train movements which were possible were those which could not in any way interfere with the northbound route.

Similarly the westbound route would be "set" by the signal man, by first

closing the derailing switches at K and I, and leaving those at C, S, F and E open, thus blocking all conflicting routes. In indicating this route, the signal at K would first be cleared, and then the distant at J. The dwarf signal for the derailing switch at I being used to govern a movement in the opposite direction to that for which the signals have been cleared is locked in the stop position, as it would not be good practice to allow signals governing movements in the opposite direction on the same track to be cleared at the same time.

On some lines, especially in the West, a certain contingency or rather a certain form of human weakness is guarded against by what is called a mechanical time lock. The object of this device is to prevent a route once set from being either suddenly or ar-

If for any cause the signalman should endeavor to throw the derailing switch open in the face of an advancing train which had just previously been signaled to come on, the raising of the distant, for example, at J, would be the first act of a series, of which opening



SIGNAL TOWER AND SEMAPHORES AT A RAILROAD DIAMOND.

the derailing switch at K would be the really disastrous, and the last. A mechanical time lock is, therefore, applied to the lever of the home signal, so that when the route has been "set" and the signal pulled down, it cannot be raised to the stop position and the derail lever released until the lapse of a certain specified time, and this inability of the signalman to open the derailing switch prevents the arbitrary alteration of the other signals or of the route.

The principle of the mechanical time lock, as made by the Union Switch & Signal Company, is very simple and in a sense it embodies the principle in-

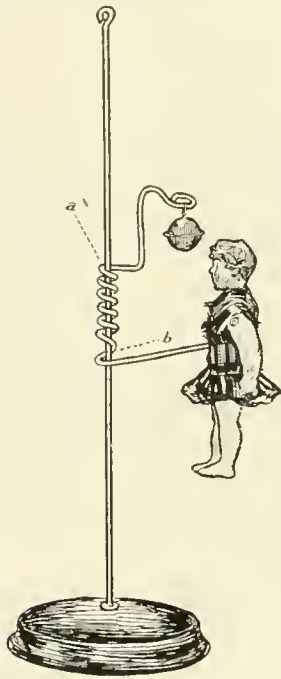

FIG. 2. DANCING DOLL.

bitrarily altered in the face of an advancing train.

For example, a train moving along the westbound track might find the route "set" and signals properly displayed. It might have found the distant at J in the proceed position and moved forward with derailing switch closed and home at K lowered only to see, as it came forward, at the last moment, the home signal at K swung up into the peremptory stop position and the derailing switch opened when it was too late to stop. Such cases have been known to occur and it is to thwart a wrong movement on the part of a sleepy or hasty signalman that the time lock has been introduced. The time lock provides that a route once "set" and "signaled" shall endure for a definite period of time.



TYPICAL "DIAMOND" CROSSING.

geniously adapted by toy makers to the little dancing doll which is commonly sold on the streets.

The dancing doll is a little china figure about two inches high, clad like Joseph, in a coat of many colors. The doll is supported by a small steel wire

standing out at right angles to the body, the other end wound in a loose coil about a straight piece of stout copper wire. When at rest, the top of the coil remote from the doll touches the upright copper wire at a, Fig. 2, and the bottom of the coil at the junction of the supporting wire, b, also closely hugs the upright stem. To make the doll "dance," the loose coil is easily slid up the vertical wire and the doll

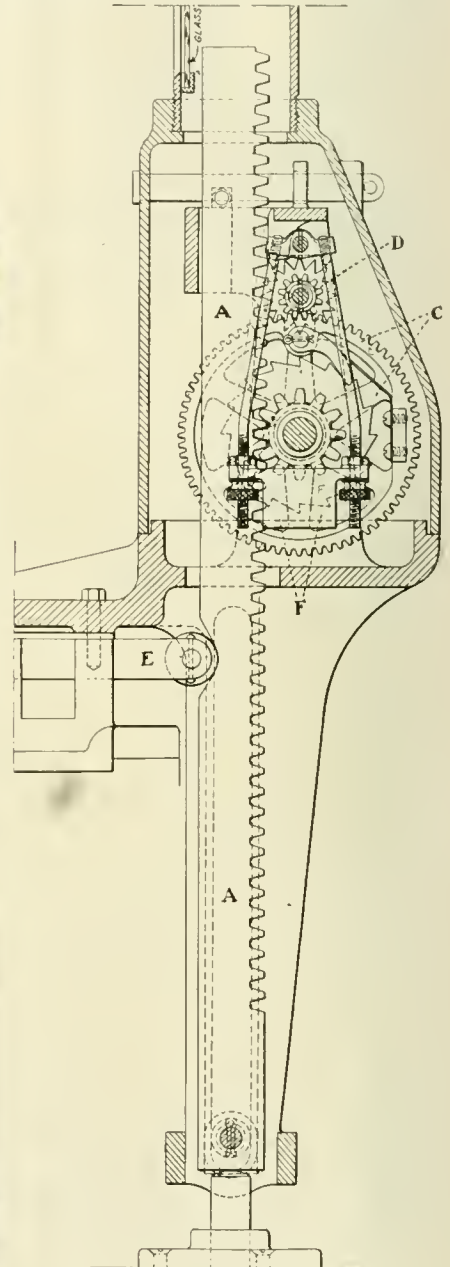

FIG. 3. MECHANICAL TIME LOCK

released so that a vibratory motion is imparted to it. The springiness of the supporting wire and the alternate clip and jamb of the loose coil on the copper stem are sufficient to prevent any continuous slide of the little figure. Its center of gravity being so far from the line of support that the up and down vibrations of the doll continue during its entire course down the rod. As much as ten seconds may thus be

occupied by the doll in traversing the distance, up which it can be drawn in a fraction of a second.

The mechanical time lock is securely fastened in a case, and though it has no external or entertaining feature like the doll, it nevertheless depends upon the time a vertical bar takes to descend when hampered in its fall by a vibrating mechanism, and the bar, like the dancing doll, can be raised to the desired height in the fraction of a second.

In our illustration, Fig. 3, A is a vertical rack bar engaging with the similar teeth of a ratchet wheel B. The long teeth of the ratchet wheel engage with a pawl attached to the gear C, and the teeth of this wheel gear with a pinion D which has a small clock work escapement wheel keyed on the same shaft. The escapement and pendulum are easily discernible in the figure, in which the pendulum is marked F. In the back of the upright bar A, near the top, is a notch in which lies a small



DERAILING SWITCH ON A TROLLEY LINE
AT A RAILROAD CROSSING.

roller wheel at the end of a locking bar E. As A rises the locking bar is moved to the left and remains in that position until notch and roller again coincide, when A has run down to its original position.

The movement of the lever of the home signal raises the bar A up to the desired height and it does so in the time occupied in clearing the signal. The raising of A pushes the locking bar E to the left and the lever cannot now be returned to its former position until the bar A has dropped again. When once A has been raised the pawl carried the wheel C around and causes the pendulum to vibrate, and the escapement to step off a long series of consecutive short drops and halts, for the vertical bar A. As much as a minute, if necessary, may be occupied in letting A sink down to the unlocking position, from which it may have been raised in something less than two seconds.

The time lock in an interlocking tower is a check on hasty action on the part of the signalman and is thus a valuable safety appliance. In locking up the derailing switch lever for a certain space of time, the time lock, in effect, says to the signal man, "Stop, think! before you act." Its clockwork mechanism, like the metronome of a musician, beats the time and marks the rests which are indispensable for the harmony of the whole.

(To be continued)

Front Ends and Steam.

The subject of the Traveling Engineers' Convention brings to mind one of the subjects carried over from last year, and one in which the writer has always taken considerable interest, viz., Locomotive Front Ends.

At the last meeting, the observant listener was no doubt impressed, if not surprised, with the various views promulgated, and the variety of means and devices that have been tried, all used to obtain the same results. How one man obtained good results by the application of a petticoat or draft pipe, while others obtained equally good effects without it. How some wanted the deflecting or diaphragm plate ahead of the exhaust stand, while others preferred it behind. In fact, the entire discussion would, to the uninitiated, appear as though all were either groping in the dark, or else working at the wrong end of the boiler to obtain the desired results.

Since listening to the discussion and reviewing the ground covered, the writer has been giving this matter some serious thought along the latter lines, and while I do not maintain that the arrangement of the front end has no influence on the steaming qualities of a boiler, or on the consumption of fuel, yet the idea will not dawn, that the same effort expended on the modification of the boiler with a view toward improving the circulation, would bring far better and more immediate returns.

For the sake of argument I should like to advance the following: The design of the front end, so long as it is adjusted to allow the draft created by the exhaust to work equally on all parts of the fires, and at the same time not seriously obstruct the products of combustion in their escape, has no material influence on the steaming or fuel consumption of the locomotive, providing the boiler is so constructed as to allow free circulation of the water, and the heating surface of the fire box and flues are properly proportioned.

In support of this argument, I can simply follow the discussion at the last convention, in which the same results were said to have been obtained in the

same engines, by different parties, by entirely different means; as for instance, one man using the draft pipe while another threw it out; one man carrying his diaphragm plate in the front end, while another carried it on the back of the tank, etc., etc.

We can go still further and take the net results of the experiments conducted at Purdue, which, boiled down, are simply tantamount to an acknowledgment that even the best designed and arranged front ends and draft appliances will not produce a surplus of steam in a poorly designed boiler, without resorting to that old expedient of reducing the exhaust nozzle tip, a fact recognized by the earliest locomotive builders, as proven by the use of the variable exhaust nozzle by Millholland in 1850, who used a variable nozzle consisting of a brass tip tapered from $6\frac{1}{2}$ ins. to $4\frac{3}{4}$ ins. inside, within which was placed a hollow frustum of a cone, or conical ring, $2\frac{5}{8}$ ins. in diameter which could be moved up so as to close the annular space or opening around it, and have only the central orifice of $2\frac{5}{8}$ ins.

In the same engine Millholland also used the petticoat pipe, which was 10 years afterward patented in England, its single purpose, according to Colburn, being to distribute the draft equally over the grate, by creating an equal draft through all the flues.

The diaphragm came into use later. The first recorded instance of its use, as far as the writer can find, being by a Mr. Geo. Fletcher of Farnham, England, in 1861; his device being in sections and worked upon the same principle as the Venetian blind, by means of a screw arrangement passing through the top of the smoke box.

About this time, however, it was also noticed that leaving out the two vertical center rows of flues, had quite an appreciable effect on the steaming of the boiler, and many boilers were afterward so constructed in England. Why this practice was discontinued we can not say; but probably some one considered it too great a loss of heating surface, and so again started the fashion of a multiplicity of tubes; in some cases, and very recent, too, the craze extending so far as to necessitate the trimming of the rivet heads in the bottom seams in order to allow the flues to be placed in position. Boilers of this kind are not noted for their free steaming regardless of the type of front end draft arrangement used.

I have always been taught to believe that the exhaust nozzle must be exactly in line with the center of the stack, in order to obtain good results. If this is true, how can we explain the fact that the best steaming engines known were the old Mason engines

with the boiler resting on a center casting and free to swing from side to side over the frames and cylinders as the engine curved? The writer was familiar with quite a number of this type of locomotive, which were in use on a road consisting almost entirely of curves, in which case the boiler would be continually swinging from side to side, from 4 ins. to 8 ins. to either side of the center line, and, of course, carrying the stack with it, in which manner the nozzle was continuously from 4 ins. to 8 ins. out of line with the stack, and yet these engines steamed free with

road tests, the writer obtained 50 per cent. more work per pound of coal, expressed in ton miles per hour, out of a geared engine with 3 upright cylinders, than he could out of a locomotive of the usual consolidation type, the consolidation being in first class condition and correctly handled by both engineer and fireman. The difference in the two engines as related to the conversion of the coal into work was principally in the boilers and the relation of fire box and fire heating surface. The consolidation had a fire box heating surface equal to 8.6 per cent.

There being four holes and more can be drilled, the possibility for adjustment is complete, and the strain on the two studs holding the plate are comparatively light.

Since this ingenious nut lock has been used the trouble with loose pins has been entirely eliminated together with the constant work of reaming nut pin holes in the crossheads and the chance of serious failures in this direction is reduced to a negligible quantity.

Saved by a Dog.

"Yes, indeed, we have some queer little incidents happen to us," said the fat engineer. "Queer things happened to me about a year ago. You'd think it queer for a rough man like me to cry for ten minutes, and nobody hurt, either, would you? Well, I did, and I can almost cry every time I think of it.

"I was running along one afternoon pretty lively when I approached a little village where the track cuts through the streets. I slacked up a little, but was still making good speed, when suddenly, about twenty rods ahead of me, a little girl not more than 3 years old, toddled onto the track. You can't even imagine my feelings. There was no way to save her. It was impossible to stop, or even slack much, at that distance, as the train was heavy and the grade descending. In ten seconds it would have been all over; and after reversing and applying the brake, I shut my eyes. I didn't want to see any more.

"As we slowed down my fireman stuck his head out of the cab window to see what I'd stopped for, when he laughed and shouted at me: 'Jim, look here!' I looked, and there was a big black Newfoundland dog holding the little girl in his mouth, leisurely walking toward the house where she evidently belonged. She was kicking and crying, so that I knew she wasn't hurt, and the dog had saved her. My fireman thought it funny, and kept laughing, but I cried like a woman. I just couldn't help it. I had a little girl of my own at home."—*Galveston Tribune.*

Last year the Canadian Pacific Railway applied the Schmidt steam superheater to one of their locomotives and proceeded to carefully watch its performance. The engine was kept in very hard service during the whole of the terribly severe Canadian winter. The officials of the company are so well satisfied with the working of the superheater that an order has been given to put it upon eighty more engines. The only difficulty encountered with the superheater was the lubricating of the cylinders. A pump to inject ordinary cylinder oil mixed with Dixon Graphite ended the lubricator difficulty.

8 Holes $\frac{13}{16}$ dia. x about $1\frac{1}{10}$ centers

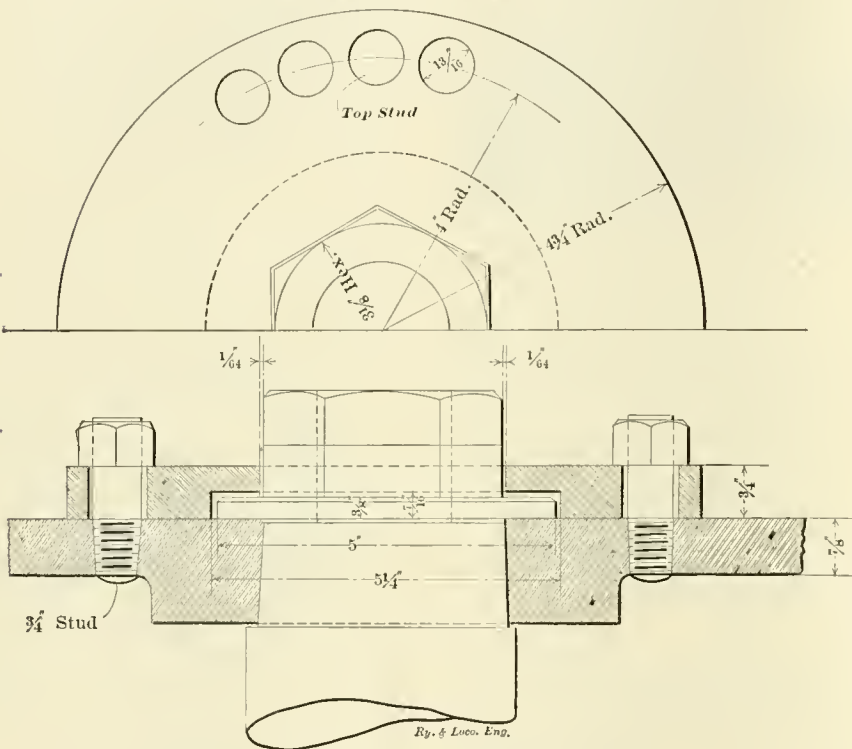

WRIST PIN NUT LOCK.

a large nozzle, and were very light on fuel.

Another point in regard to these engines which upsets some of our favorite theories, was the fact that the front ends were anything but air tight, and frequently, when a nozzle plate spring was broken, we would have an opening or hole in the front end equal to 24 sq. ins., and yet that appeared to make no material difference.

In fact in this and many other instances have we seen so many of our pet theories upset, that a little skepticism on the subject of front ends may be pardoned.

A word in conclusion. The energy produced by the combustion of a pound of coal, when converted into work, should be nearly equal, regardless as to whether it is produced by a direct thrust of the piston against the crank, or transmitted through a series of gears; and yet in a number of repeated

of the flue heating surface, while that of the geared engine was 15.39 per cent.

Slater, Mo. F. P. ROESCH.

Wrist Pin Nut Lock.

Our illustration shows a wrist pin nut lock used on the Michigan Central. It is the invention of Mr. D. R. MacBain, master mechanic at Jackson, Mich. The nut lock is very simple in its construction, being a $\frac{3}{4}$ in. circular plate recessed out on the under side to allow for the collar of the nut. In the center of this plate a hexagon opening has been cut through which is just $\frac{1}{16}$ of an inch larger than the nut which it surrounds.

The various positions which the "flats" of the nut may assume is provided for by drilling four holes on each side of the plate, two of these holes are in use, no matter where the nut stands when it is screwed up tight.

General Correspondence.

Method of Laying Off Shoes and Wedges.

This is a drawing and explanation on laying off shoes and wedges on offset frames where the rocker box and hanger on the fire box are in the way of the trams.

The Northern Pacific here have a lot of engines that have offset frames. The offset being just behind the main jaws the fire box fits down into the offset and is fastened to the frame by hangers. These hangers are on pins and the lower pins are pressed into the frames. The pin in the frame, BI, on the drawing extends some 8 ins. outside of frame and with or without hanger, AI, in place is a source of great annoyance in laying off the shoes and wedges. The

was put across the main jaws and squared to lines.

The square lines were then put on frame by hanging a square down from top of frame and letting the blade touch the straight edge and a line drawn down on the front edge of the square. This was done on both sides of the engine. The frame was layed off by finding centers of jaws at points, A. The centers on the main jaws were to be the same distance from square line on jaws. Then the center, A, on the front and back jaws were the same distance apart as the length of the side rods. The next step was to draw a line parallel with top of frame through A, then take half the size of the driving box and set dividers this size, and scribe an arc right and left of

Call the pops near the top of shoe, H, and the pops near the bottom, G. Now a line drawn down the shoe from H to G will be parallel with square line on jaw. This being done on both main jaws we proceed to front and back jaws and do the same as on main jaws. This gives the two outside pop marks for the planer man.

The inside pop mark is found in the usual manner by putting straight edge across the shoes and set it the same distance from G on both sides of the engine and a pop on inside of shoes the same distance, which gives the inside pop for planer. We lay off the wedges at the same time, the following method being used: Scratch a line across wedge at top and bottom same distance from

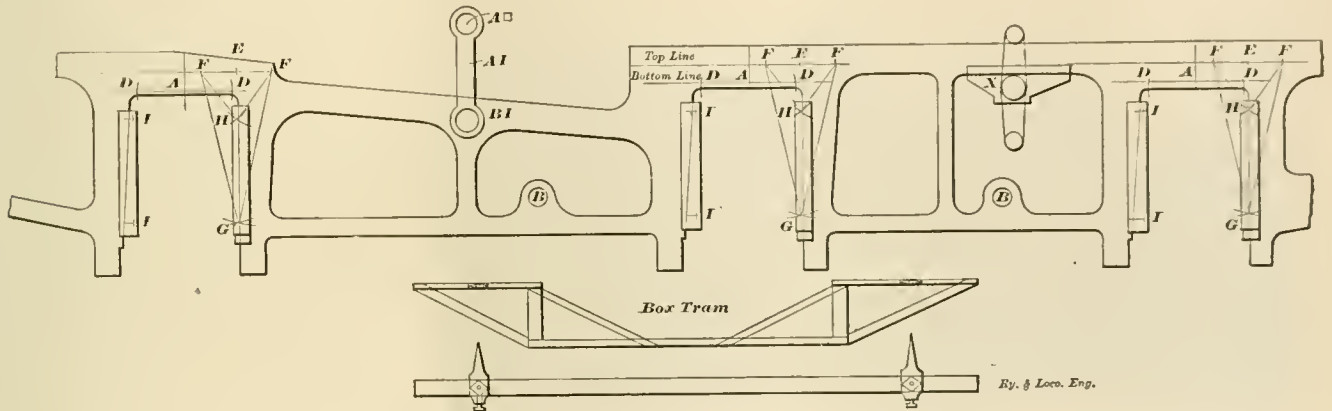

PERCY'S METHOD OF LAYING OFF SHOES AND WEDGES.

B on drawing is a brake hanger pin. The rocker box is an annoyance in view of the fact of its not always being taken down for repairs. It projects some 11¼ ins. from the frame on the outside. This rocker box is marked X. It is customary to use a box tram in laying off the shoes and wedges on these engines.

This train is very uncertain and also very inaccurate, as it is made of light material and is, as the sketch will show, very limber. A straight tram with very long points is sometimes used in preference to the box tram, but is equally as uncertain. George Lovett, a fellow machinist here, and myself, layed off 2 or 3 sets of shoes and wedges without the use of the long tram with the long points or the box tram and they came out line and line. We layed them off in the following manner. The lines were run through the cylinders to the back end of the engine and set accurate in cylinders. Then the straight edge

A, using A as a center. We will call this size on drawing the box size and mark these pops with a letter, D.

Now in this explanation we will draw another line parallel with the top of the frame to lay off the shoes with. Transfer the center of jaws up to this line and open dividers one inch larger and using top center for a starting point we scribe an arc across top line and call this point E on drawing. We then set dividers at any given size, say 8 ins., and with one point resting on E we scribe an arc on both sides of it and put center punch marks at F. A short pair of trams, say 24 ins., is then used and one point set in F and the other set long enough to reach 2 or 3 ins. from top of shoe, then scribe an arc across top of shoe from both of the Fs. Where these lines intersect on shoe put a pop mark. Then do the same on bottom of shoe by lengthening out the tram to 2 or 3 ins. of bottom of the shoe, putting pop marks where these lines intersect.

top of frame as points, H and G, then take small trams and set them 2 ins. larger than size of driving box and put one point in H and cross top line on wedge, then do the same at the bottom using G for the starting point and cross bottom line and put pops where these lines intersect and call the points I. The same method is used in putting a point on inside of wedge for the third pop. In drawing the lines on frame parallel to top at the front and back jaws they must be drawn with a short straight edge, which is to be leveled with a level set to main jaw lines or else the bottom pops on shoes will be closer or farther apart than the top ones. The shoes and wedges are lined up enough to allow the distance from pops H and G to face of same to be exactly 1 in. when planed. In planing them the planer man makes them all the same, 1 in. If the planer man does not plane them all the same the engine as a consequence will be out of tram.

JOHN W. PERCY.
No. Pac. Shops, South Tacoma.

To Test for Blows in Valves, Cylinder Packing, Separate Exhaust Valve and Intercepting Valve.

BY S. H. DRAPER.

First—Place engine with low pressure side on bottom quarter, valve blanked, low pressure cylinder cocks and separate exhaust valve open. If a blow is indicated at the stack and cylinder cocks, we have either a defective low pressure valve, intercepting valve, bypass valves or a blow in the high pressure side. To determine which it is, leave the throttle open and close separate exhaust valve. If blow stops and intercepting valve moves back it would prove that low pressure valve, separate exhaust and bypass valves were O. K.; if blow did not stop, it would indicate that low pressure valve or separate exhaust valve or bypass valves were not tight. If intercepting valve remained forward, it would indicate separate exhaust valve blowing; if it moved back into compound position it would indicate separate exhaust valve

was passed forward end of intercepting valve and that outside rings on high pressure valve, bypass valves and forward rings on intercepting valve were O. K. If blow does not stop, it is either the outside rings on high pressure valve, bypass valves or forward rings on intercepting valve that is blowing. To determine which it is, the quickest way is to make an examination: First, the bypass valves; second, the high pressure valve, as either of them are more liable to blow than is the intercepting valve. However, if no blows are found that would require the examination, we are ready to test the inside valve rings and cylinder packing by moving the reverse lever forward far enough to partly open forward port, cylinder cock 2 open; if steam blows quite strong at cylinder cock, the forward inside rings or cylinder packing is defective. To determine which it is, place reverse lever in full forward gear, and if blow stops, cylinder packing is O. K. and inside forward

blow occurs under these conditions at the stack, it proves that forward packing rings on intercepting valve are defective. It is not known that high pressure valve is tight, it is impossible to determine which is blowing without an examination, as all these blows go to the receiver and to stack, while separate exhaust valve is open.

TO LOCATE BLOWS AND DEFECTS IN THE MODERN SCHENECTADY CROSS COMPOUND.

It will sometimes occur that the engine will develop a heavy exhaust at one end of low pressure cylinder and a light one at the opposite end, with no derangement of valve motion; there are four prominent causes for this.

(1) If a slide valve is used.

A broken valve yoke, which would not give a full forward port opening; this would hold receiver pressure back and when back port was open, the receiver pressure being higher, would fill that end of cylinder with a higher pressure; hence, the louder exhaust, but no blow at stack, and intercepting valve will remain in compound position.

(2) The second cause for loud exhaust would be a piece broken off of either side of the valve or valve seat, which would result in opening the port earlier on the side of valve that was broken and closing it correspondingly later, all of which would serve to reduce the receiver pressure below normal, when that port was open, leaving a smaller volume of steam in receiver to fill the opposite end of cylinder when port is open. Hence, one loud and one light exhaust, generally accompanied with blow at stack.

(3) Cause would be due to very leaky packing rings and ground joint on the back end of intercepting valve or vent port stopped up, which would allow the pressure to build up and force intercepting valve forward far enough to partly close off receiver steam from reaching low pressure steam chest, but not far enough to register live steam ports to low pressure steam chest; the receiver steam being so closed off, soon builds up high enough to force intercepting valve back. As soon as forced back, receiver pressure immediately falls by flowing into the low pressure cylinder, causing a reduction in receiver pressure which allows the intercepting valve to again move forward and repeat the above operation, resulting in one light and one heavy exhaust.

In this case there will be no blow at the stack, but you will observe the intercepting valve moving forward and back when engine is working. However, it is sometimes difficult to determine whether the trouble is in the intercepting valve or not. To make sure of it, fasten the intercepting valve

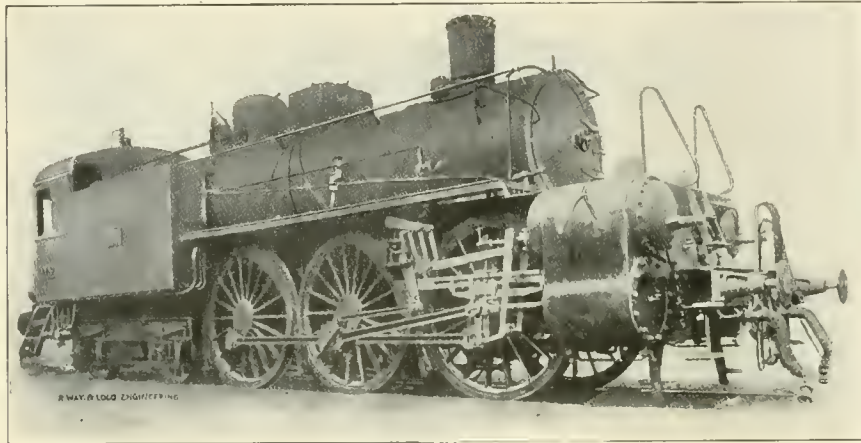

4-6-0 ENGINE ON THE ADRIATIC RAILWAY OF ITALY.

tight, and low pressure valve or bypass valves blowing. If no blow, they are O. K. Test cylinder packing by dropping lever forward as in case of simple engine.

To test high pressure side, place engine on bottom quarter, cylinder cocks on that side open, separate exhaust valve open, blank valve, give engine steam. If a blow is indicated at the stack and cylinder cocks, it is either the high pressure valve, forward end of intercepting valve or bypass valves. To determine which it is, remove nut on intercepting valve stem, slip on a piece of pipe of proper length and replace nut. This will hold intercepting valve back in compound position, thereby preventing high pressure steam from reaching low pressure steam chest and blowing by the forward end of intercepting valve and out of separate exhaust to stack. Therefore, if blow is stopped by fastening the intercepting valve back, it proves that blow

rings defective. If it did not stop blow or diminish it, it would indicate defective cylinder packing. If it diminishes the blow, it would indicate both cylinder packing and forward inside rings defective, testing back inside rings in same manner by putting reverse lever in back motion.

In conclusion, will say the blow that occurs by the forward end of intercepting valve, when engine is working simple, does not in any manner affect the engine when working compound. However, if the forward rings on the intercepting valves are blowing, it is a steady blow in the receiver while throttle is open, raising the receiver pressure above normal. This blow cannot be located unless it is known that high pressure valve and bypass valves are tight. If they are tight, all that is necessary is to blank high pressure valve, fasten intercepting valve back, as above stated, open separate exhaust valve, and give engine steam. If a

back in compound position by removing the nut on intercepting valve stem, slipping a pipe of proper length over the stem, replacing the nut. If engine then sounds square, it proves that trouble was with the intercepting valve. If it did not sound square after fastening intercepting valve back, it would prove that the defect was some one of the other causes.

(4) The fourth cause would be broken or defective low pressure bypass valve, which would cause a bad blow at the stack while the piston is traveling one way only. The defective one is easily detected by noting which end of the cylinder is open to exhaust, when blow occurs, or in other words, the defective bypass valve is the one toward which the pistons are traveling when the blow occurs. Occasionally after stopping, we find our engine will not start; we look around and find that engine stands with right or low pressure side on top or bottom quarter, high pressure side on dead center. We give engine steam and observe that intercepting valve does not move forward. This indicates one of two things: either the intercepting valve is stuck for the want of oil, or the separate exhaust valve is disconnected, cocking in such a manner as to prevent the intercepting valve from moving forward to open live steam ports to low pressure steam chest.

We will first open throttle and strike end of intercepting valve stem a light blow, and if valve is stuck it will generally move forward, which would indicate that the valve was in need of oil. If it did not move forward with a light tap, would take off cylinder head to separate exhaust valve to examine it. If the valve stem is broken, all that can be done will be to remove the broken parts and pull the valve to its seat and proceed. If the separate exhaust valve is O. K. and the intercepting valve moves forward, and still engine will not start, it would indicate that the reducing valve in the intercepting valve was stuck closed; and sometimes by a jar on the intercepting valve stem, with throttle open, it will loosen it. If not, it will be necessary to take intercepting valve out and loosen up the reducing valve.

Missoula, Mont.

Creeping of Left Hand Rail.

On page 273 of the June number attention is called to the excessive creeping of left hand rail on double track roads, and it is referred to as a phenomenon. There is really nothing phenomenal about it. A Mr. O'Busse, of Copenhagen, is quoted as saying: "It has been proved both theoretically and practically the left hand wheel of

a locomotive becomes deformed, and consequently all the locomotives on the line have their tires deformed more or less," also "that if locomotives had a free path they would always run to the left, because of excessive wear of left wheel"

If it were proven "both theoretically and practically," as Mr. O'Busse says, that left wheel shows excessive wear, the very proof itself would suggest a remedy, which, if not complete would at least reduce the evil effects of unequal wear of tire in so far as rail creeping was concerned 50 per cent. If the left driving wheel, or to be more precise the left main driving wheel, shows excessive wear it is because the right engine is the leading one. If the left engine be the leading one the excessive wear will be developed on the right side. Now it seems reasonable to suppose that if the creeping of rails has become a matter of serious importance this remedy would be applied, which is, that 50 per cent. of the locomotives be made left lead engines. In this way

side, which, in a measure, counteracts the tendency of the left main wheel to carry engine so flanges would bear continually against left rail. But even admitting that all engines did run to the left, what has that to do with uneven wear of tread of wheel or creeping of rails?

We always had flat wheels, but we did not know it. With the type of engine having but four coupled wheels the unequal wear was not so great for the reason that the proportion of adhesive power was favorable to uniform wear of tire, the action causing uneven wear taking place chiefly when getting train under headway or working to full capacity at slow speed, while in the case of engines having six or eight coupled wheels the action referred to is continuous.

T. P. WHELAN.

Bellevue, O.

It has been some years since I have had anything to say in the columns of

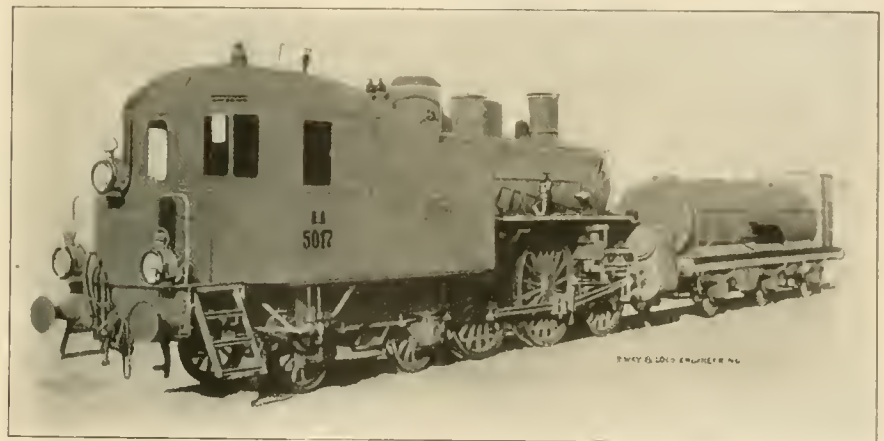

ENGINE RUNS CAB FIRST—ADRIATIC RAILWAY OF ITALY.

the effect would be reduced to a minimum in so far as its effect on the condition of track. That this remedy has not been resorted to proves either one of two things. That the real cause of unequal wear of tires is not clearly understood, or that the evil effects, such as rail creeping, have been exaggerated.

Mr. O'Busse apparently attributes the evil effects to difference of circumference in driving wheels causing engines to run to the left side. Excessive wear, of course, reduces size of wheel somewhat, but as that wear takes place chiefly in the left main wheel its tendency to carry the engine to the left rail does not produce that result, as the uneven wear of left main wheel is but slightly imparted to the other coupled wheels, and it is also true that the wear of right main wheel is greater than other driving wheels on that

your always interesting journal, but the article in the June issue, page 273 on creeping of left hand rail induces me to break silence. It was my misfortune to be connected with a railroad for about as long as the average life of man, and I was master mechanic for many years on a division that was comparatively level, and on which tires flattened much the same as on other more hilly divisions. My experience was that distortion on left side always preceded the right side. You doubtless remember this subject was up in your journal some eight or ten years since, in which discussion I took an active part, and took the stand that the defect was not only in the tires but affected the entire left side of engine from foot board to cylinders. I am not prepared to deny or confirm Mr. O'Busse's claim as to cause of creep- (Correspondence continued on page 370.)

Railway and Locomotive Engineering

A Practical Journal of Railway Motive Power and Rolling Stock.

Published Monthly by
ANGUS SINCLAIR CO.,

174 Broadway, New York.

Telephone, 984 Cortlandt.
Cable Address, "Loceng," N. Y.
Glasgow, "Locauto."

Business Department:
ANGUS SINCLAIR, President.
FRED M. NELLIS, Vice-President.
JAMES R. PATERSON, Sec'y and Treas.

Editorial Department:
ANGUS SINCLAIR, Editor.
F. M. NELLIS,
GEO. S. HODGINS, } Associate Editors.
JOS. A. BAKER,

Advertising Department:
Eastern Representative, S. I. CARPENTER, 170 Summer St., Boston, Mass.

British Representative:
THE LOCOMOTIVE PUBLISHING CO., Ltd., Amen Corner, Paternoster Row, E. C., London.

Glasgow Representative:
A. F. SINCLAIR, 15 Manor Road, Bellahouston, Glasgow.

SUBSCRIPTION PRICE.

\$2.00 per year, \$1.00 for six months, postage paid to the United States, Canada and Mexico. For other parts of the world, \$2.50 or ten shillings. Single copies, 20 cents. Remit by Express Money Order, Draft, Post Office Order or Registered Letter. Mailing address can be changed as often as necessary—always give old and new address, and if you subscribed in a club, state who got it up. Please give prompt notice when your paper fails to reach you properly.

Entered at Post Office, New York, as Second-class mail matter.

Copyright by Angus Sinclair Co., 1904.

For Sale by Newsdealers Everywhere.

Investigating Locomotive Boilers.

It is safe to say that no member of industries or engineering equipment has received more exhaustive attention or more scientific investigation than the design, construction and care of steam boilers. Ever since boilers were required to generate steam above atmospheric pressure the attention of the leading spirits in the mechanical world has been devoted to making the vessels safe, durable and capable of using the heat applied to the best advantage. The principal function of a steam boiler is to generate and absorb heat which goes to the water inside. That boiler which provides for the most efficient combustion, prevents radiation to the greatest extent, provides the circulation of water necessary to carry away the heat from the fire surfaces and passes the least amount of waste heat into the smoke box is likely to be the most economical. To bring about these conditions has received persistent efforts from the engineers of many generations and the work is still industriously pursued.

What has been done to promote the efficiency and durability of locomotive boilers would fill large volumes, but the story is comprehensively told in the numerous reports of committees submitted to the American Railway Master Mechanics' Association and in the verbal discussions excited by the reading of the

reports. When the Master Mechanics' Association was organized in 1868, 48 ins. diameter was a large boiler, and most of those in use had iron shells and iron fire boxes that lasted about three years under a steam pressure of about 120 pounds to the square inch. Copper fire boxes were sufficiently numerous to compare their efficiency and durability with iron and the decision of the leading railroad master mechanics was that copper ought to be dispensed with.

In those days the conventions were very decidedly experience meetings and the railway world received the benefits of many carefully conducted experiments undertaken to demonstrate the value of different materials and the effect of changes in form and dimensions made to test the utility of different proportions. For years the best proportions of tubes, both length and diameter, were exhaustively investigated and different dimensions and water spaces were experimented with until a satisfactory average was established, with always a tendency to recommend that all the water spaces be made of liberal dimensions and protests were promptly heard when a tendency was displayed to magnify heating surface at the expense of the open spaces needed to permit the water to circulate freely.

As worthy marks of progress we trace the changes of material from iron to steel and note the cautious reports with which the new material was received, and how only by proving incontestably its superiority to iron, was steel admitted as fire box material. Then there were carefully watched experiments with steel in boiler shells and its final triumph.

The work of the Railway Master Mechanics in improving the locomotive boiler was zealously supported and in some cases led by the locomotive builders, so that the best professional talent of the country was devoted to perfecting the boiler. It was gradually increased from a diameter of about 48 ins. to 72 ins. and over, all parts being enlarged in proportion. The steam pressure has been increased from about 120 pounds to about 200 pounds to the square inch and all parts increased so that they resist the high internal pressure as successfully as the boilers that carried the lower pressure. Structurally the locomotive boiler is as nearly perfect as any member of the steam engine's attachments. The faults and weaknesses of the locomotive boiler are like those inherent to any vessel or apparatus which has to endure severe usage. The fire box sheets become distorted and frequently crack, tubes give much annoyance by leaking, stay bolts break from natural causes and explosions sometimes happen; but there is no mystery connected with these sources of decay. They are all the result of hard work, and as long as boilers are fre-

quently forced to their utmost capacity the stresses of hard service will be always manifested.

We have heard the question asked repeatedly of late: "Why is it that locomotive boilers belonging to European railways give almost no trouble from leaky tubes and cracked fire box sheets?" The answer is that European locomotives are not required to do nearly the same amount of work forced habitually from ours. Even with the small grate area common in European locomotives, few of the engines are required, when working at their hardest, to burn 100 pounds of coal per hour to the square foot of grate, while many of our engines have frequently to burn more than double that quantity.

At the last Master Mechanics' Convention the committee on boilers recommended that laboratory tests be made for the purpose of determining the rapidity of circulation in a boiler generating varying amounts of steam up to its maximum, and also for determining temperature in the sheets where the greatest trouble is experienced. That proposition appealed so favorably to some of the members, that a resolution was passed directing the executive committee to obtain from railroad companies five thousand dollars to defray the expense of such tests. Now the question arises what advantage would railroad companies derive from tests that would demonstrate the rapidity of the water circulation and the temperature of the hottest sheets? Would it enable them to save a pound of coal while forcing the process of steam making to its utmost? Not a pound. The people who have charge of locomotive operating are perfectly aware that high sheet temperature could be prevented by giving the boiler less work to do; but they take the practical stand that a locomotive boiler is made to generate all the steam the cylinders require and they have no sympathy with schemes to reduce the engine's efficiency, even if they propose to prolong the life of side sheets. As for circulation of the water inside the boiler, that has been clearly demonstrated long ago by the use of glass boilers and steel boilers having glass disks through which the movement of the water could be seen.

There have been many foolish schemes tried upon the railroad mechanical associations, but the proposal to spend five thousand dollars on investigating things that could not be altered displays the least common sense of any of the investigating absurdities.

Locomotive Collisions as a Public Spectacle.

A very sensational Fourth of July entertainment held at the Point of Pines, Revere Beach, near Boston, was,

if the local papers are to be believed, a dismal failure. It was nothing more or less than the pre-arranged and public head-on collision of two locomotives, light of course, but under full steam.

The engines were rather decent looking 4-4-0 machines with straight top boilers and diamond stacks and were said to have been in branch service about a month ago on the Boston & Maine. They were bought for the purpose of being "butchered to make a Roman holiday," probably because they had reached the scrapping point as far as railroad operation was concerned, and the B. & M. no doubt received the scrap price and turned them over to the collision enthusiasts.

The idea was to sell tickets to all and sundry who wanted to see a railroad collision, but the collisionists failed in some way to produce the spectacle which was expected and a riot took place in which several persons were injured, and we are told in one of the press dispatches that a mob of several thousand people tore the locomotives to pieces and set fire to the cabs.

We are not exactly concerned as to how several thousand persons, presumably holiday spectators without tools or the knowledge of how to use them, could tear two locomotives to pieces for failing to collide as advertised. RAILWAY AND LOCOMOTIVE ENGINEERING has always taken strong ground against such exhibitions for the reason that they do not tend to do any good and in the case before us changed what ought to be a peaceful and happy throng into an angry mob.

If a pre-arranged head-on collision between two engines helped forward our knowledge of how to prevent collisions we would applaud such experiments. In serious railroad operation a collision between two locomotives represents a most grievous human failure of some kind and is in most cases accompanied with such a deplorable loss of life that we cannot say a word in favor of such a reproduction, even if it be known beforehand that no one will be killed.

Our idea is that any sane man who has seen a bad railroad accident and all that it entails will thank God if he never sees another, and these "fake" accidents should be discouraged as tending to demoralize the honest and the serious view of human responsibility in railroad operation.

We have altogether too many misinterpreted or wrong train orders in everyday railroad life and too many cautionary and stop signals passed, to joke about the terrible results which usually follow in each case by getting up an exhibition accident.

We have no quarrel with those who endeavor to take in legitimate receipts for a pleasant excursion, or who give

an exhibition of strenuous human endeavor, say in saving life, or of how people can be helped, or how they can help themselves, in cases of fire or other emergency. We are, however, constrained to protest when what in ordinary railroad operation can only be the result of human weakness or folly and is usually accompanied with the cruel death of innocent people, is turned into a mere money getting spectacle which does not amuse or tend to elevate the minds of the onlookers.

Mechanical Stokers.

A report on automatic stokers presented to the last Master Mechanics' Convention, deserved much more consideration than it received; but it brought forth a slightly animated discussion which may help to let the people concerned know that the automatic stokers in use are performing good work. The first three paragraphs of the report constitute a statement which ought to appeal to every railroad manager in the country who is interested in keeping down operating expenses and in mitigating the smoke nuisance which gives so much reason for complaint among the people with dwellings near railroad stations, to say nothing of passengers riding on railroad trains. The part of the report we refer to reads:

"The only comparative test that your committee has been able to make shows that there is a saving of not less than 7 per cent. when using the stoker as compared to the work done by a first class fireman. This, of course, would indicate a considerably greater saving as compared with locomotive firemen as they are ordinarily found. In the case mentioned, the engine equipped with the stoker was in service over its run six hours and thirty minutes, while the engine that it was compared with was only four hours and seven minutes going over the same length of division.

"The saving in coal when using the stoker is no doubt very largely due to the fact that when using the stoker the coal is much more evenly distributed, and the furnace door remains closed all the time.

"When using the stoker the smoke is very much lighter in color, indicating, of course, a much more thorough consumption of the gases. The darkest color, when the stoker is used, is not more than brown, while most of the time the emission from the stack shows pure steam."

The chairman of that committee, Mr. J. F. Walsh, superintendent of motive power of the Chesapeake & Ohio Railway, has five Day-Kincaid locomotive stokers in use and his evidence is to the effect that they do their work as well as any other part of the engine. The testimony about them is, that the stokers

apply the fuel uniformly, which is the proper way to prevent smoke and to obtain its maximum efficiency from the coal. The supply of fuel being uniform, there are no fluctuations of temperature, which as is well known do so much to damage fire box sheets and flues; so it follows that an automatic stoker from the nature of its operation must save fuel, prevent smoke and lessen the need for repairs to boiler and fire box.

For long years the most fertile subject of discussion among railroad mechanical men has been defects of boilers induced by hard service, and it seemed that no difficulty would be permitted to interfere with any improvement calculated to lessen the evil. Fuel is such an important item in railroad expenditures, that a device calculated to save 1 per cent. of the heat losses ought to be patronized with the utmost avidity, yet the automatic stoker, which gives every promise of lessening the troubles from defects of severe service and effects material saving of fuel, is offered to railroad companies at a low charge and there are no buyers. The only objection raised to the invention is that it is not perfect, and railroad companies are represented as anxious to wait for its development. There never was an appliance introduced into railroad service that was perfect, but that did not prevent enterprising railroad companies from purchasing pressure gauges, safety valves, injectors, balanced valves, air brakes and a host of other things that were imperfect when first put into service.

When firemen are groaning over the inhuman labor of keeping the fire boxes of powerful locomotives supplied with fuel, it seems strange that railroad companies will not adopt mechanical means of doing the work when money would be saved by so doing.

Ton-Hours.

The report of the committee on ton-mile statistics and the credit for switch engines presented to the Master Mechanics' Association at the June convention is a reasonable and logical argument for discarding an arbitrary credit of mileage.

Experiments which have been made in the past with switch engines fitted with revolution counters, have proved conclusively that the usual rating of six miles per hour was very much too high. The result of one series of experiments established an average of 3.75 miles per hour.

The report goes on to say even though the present credit of six miles an hour should be changed to three miles an hour so as to be nearer the truth, yet the result would still be that a 16x20 in. cylinder engine would be credited with having done the same amount of work as a 20x26 in. cylinder

switcher, if they both worked the same length of time. A master mechanic having a number of light switching engines under his charge can in this way make a much better showing concerning fuel, oil and repairs than a man whose switching power is heavy, yet the actual amount of work done by the heavy engines may far surpass that done by the light engines, but the arbitrary credit allowed falsifies the comparison. The only case in which the arbitrary credit is of any value is when it is used in comparing a group of engines, similar in every way, and in which each performs a similar amount of work.

There has not yet been any practical method devised of easily ascertaining the ton-mileage made by switch engines so that the ton-mile cannot be used in preparing statistics of switching engines. The arbitrary miles per hour rating is unsatisfactory in theory and practice, and the committee has, therefore, been compelled to devise a form of rating which will vary in some way with the work done. They have proposed a ton-hour rating, in which the weight of the drivers expressed in tons is multiplied by the number of hours the engine is in service.

The reason for choosing this form of rating is summed up in the report in somewhat as follows:

The maximum tractive power of an engine in road service is seldom used, except in starting its train or on long grades. In switching service, however, the maximum tractive power, or very near it, is used most of the time. The factors, size of cylinders, diameter of drivers, and pressure, when properly used, give the maximum power the engine is capable of developing, but it is the weight on the drivers which limits the amount of this power which is available for useful work. It therefore seems evident that, with switch engines, the weight on the drivers furnishes a simple and reasonably accurate unit for measuring their capacity for work. If this weight on the drivers, expressed in tons, is multiplied by the number of hours the engine is in service, it furnishes a credit of work done, expressed in ton-hours, which closely approximates the actual facts.

Theories About Front Ends.

Our friend, F. P. Roesch, master mechanic of the Chicago & Alton at Slater, Mo., has given our readers good food for thought in an article on "Front Ends and Steam" published in our correspondence department. Mr. Roesch has generally something to say worth reading when he puts his pen to paper and in this instance his efforts are peculiarly striking. Facts are very hard things to controvert and he gives particulars about front end conditions

that seem to knock out all our long cherished theories about air tight smoke boxes and centrally located nozzles. Mr. Roesch cites the experience with a well known type of Mason engine that had a smoke box arrangement which threw the nozzle out of center every time a curve was struck; and was very free in admitting air direct to the smoke box; yet the engines steamed well. Having experience of that kind to deal with, it seems waste of effort to theorize about minute details of arrangement of draft appliances, and to expend tedious and painful labor striving to prove things that are vain. The subject, however, is easily talked about and nearly all railroad men hold established theories about draft appliances, so it is likely that the discussions on the subject will go on indefinitely wherever mechanical railroad men meet for the exchange of experiences and of opinions.

Railroad Discipline.

"It is a well understood principle in jurisprudence that a law without a penalty for its violation partakes more of the nature of advice than of law." That quotation from Mr. G. R. Brown's publication, *A Railway Book for Railway Men*, was read by Mr. J. B. Yohe, general superintendent of the Pittsburgh & Lake Erie, in his paper on "Discipline" presented a short time ago to the Railway Club of Pittsburgh.

Mr. Yohe frankly admits that progress in the matter of railroad discipline has not been as full or as satisfactory as it has been in other departments of railroad operation. A paper like Mr. Yohe's is, therefore, most timely as it directs the minds of other thoughtful workers to a subject which is second to none as a factor in successful railway management.

Formerly discipline was enforced by fine, and often this was imposed without the employee having had a hearing. This manifestly unfair practice has practically disappeared. The "twin brother" of the money fine was the demand for full restitution for property destroyed by the one responsible. This system, however, became inoperative because it was impossible for a man on small pay to reimburse a company for property destroyed in a serious accident.

On most of our railroads the division superintendent assisted by the trainmaster conduct investigation and apportion the blame and fix the penalty. The average employee approaches such a court with the determination to tell as little as possible and quietly take what he gets. This system often results in the truth being kept back and those who decide the case are often very much in the dark.

On other important roads a board of inquiry conducts the investigation and applies the discipline. This board usually consists of one officer from each department. This plan has its good and its bad features. It is thought by many that the questioning and cross questioning to which each of those who come before the board is subjected, has a tendency to bring out the truth and establish all the facts in the case. Each departmental head is naturally anxious that "his men" will be found to have done their duty and the drift of many of his questions will be to that end. This feature is not necessarily objectionable if the investigation does not turn into a struggle between the representatives of the transportation, mechanical, and maintenance departments to put it all onto "the other fellow."

In dealing with the Brown system of discipline without punishment the speaker said that the system had been tried on some of our leading lines representing, as nearly as he could find, some 50,000 miles of road. He goes on to say that he is of the opinion that "a most thorough education on the part of employees as to the principle involved is absolutely necessary before the Brown system could be effectually introduced. On roads that select their employees from the farm hands and country boys living along their line, the matter of education is comparatively easy, and any form of discipline, properly understood, could be intelligently enforced. On roads that are compelled to select their employees from those who have seen service on, or who have been dismissed from other railways, and who are also compelled to reinforce their numbers from the floating element of railroad men, many of whom place but little estimate on the value of their positions, the question of education is far more serious, and experience has convinced me that in dealing with this latter class, the manager who insists upon his men being given a fair and impartial trial, and then imposes discipline by actual suspension or dismissal, obtains the best results."

Mr. Yohe impressed upon his hearers the great importance of having a man of wide experience in railway service to conduct investigations. Such a man should be tireless in his search after facts, yet should all the time be acting on the motto: "Put yourself in his place." The great possibilities for good of having a "heart to heart" talk alone with the man under suspicion, were pointed out and the necessity of showing him clearly the effect of the accident on the reputation of his company and on his own reputation as well. If the man was found to have misrepresented the case or had lied or withheld facts, he should be punished by actual sus-

pension, or if circumstances warranted it, by dismissal, and when the extreme penalty had been imposed it should be final.

As Other See Us.

Knowing that our readers are not interested in the kind things which people frequently write about our publications, we make it a rule to say nothing about them, but we will make an exception of the annexed letter which relates principally to our new book, "Twentieth Century Locomotives." Mr. Raps is foreman of the boiler shop of the C., R. I. & P. shops at Cedar Rapids, Ia.

Cedar Rapids, Ia., June 27, 1904
Angus Sinclair Co., New York.

Dear Sirs:—I was very much pleased to receive a copy of your book "Twentieth Century Locomotives," and my pleasure and interest have increased with its study. It is good all the way through. Where there is so much good it is hard to pick out the best.

The most profitable for any man (or woman either) are the articles between the pages 431 and 452. Those who read these articles earnestly and conscientiously cannot help getting more out of the book than if they were not read. As the author says in the preface, "The articles are capable of providing knowledge," and any one following the advice in the chapter on "Definite and Indefinite Knowledge" cannot help but get the "definite knowledge" in place of the "mass of general information."

I cannot refrain from saying a word for the author, Mr. Angus Sinclair. As an educator of railroad men he is the pioneer and ranks second to none. RAILWAY AND LOCOMOTIVE ENGINEERING and the books of which he is the author, stand as monuments to his ability and perseverance. Mr. Sinclair has educated more railroad men than any other man in the country.

Thanking you for the conspicuous place given the articles written by me some time ago (I did not think they were worth putting in a book) and heartily thanking you for the book, I wish you success.

Yours very truly,
H. J. RAPS.

The Chicago, Burlington & Quincy people are reported to have been investigating the practicability of introducing electrical traction into their suburban service, and that the scheme has been abandoned for the present because they could not find a suitable motor. That will not long obstruct the introduction of electrical power into the suburban service of steam railroads. Demand will soon bring forth a motor which will do the work.

Questions Answered

(56) Subscriber, Jeffersonville, Ind., asks:

(1) Will you please explain the meaning of the figures under the cuts in RAILWAY AND LOCOMOTIVE ENGINEERING such as 4-6-0, etc. A.—The figures refer to the wheel arrangement; in this case the engine is a ten-wheeler. It has a four wheel truck, six drivers and no carrying wheels at the back. An Atlantic type engine is a 4-4-2, which means that it has a four wheel truck, four drivers and two carrying wheels behind. (2) What is the difference between a direct and an indirect engine? A.—The words direct and indirect refer to the valve gear. To put it shortly, if a rocker arm is used so that when the eccentric rod moves forward the valve moves back and vice versa it is indirect motion. If when the eccentric rod moves forward the valve moves forward the motion is direct.

(57) Student, Woburn, Mass., writes:

Please inform me if there is any way of calculating the power of a locomotive of given dimensions, running at a given speed, with a given cut-off. I mention the speed, as I suppose there will be some allowance for back pressure. A.—When the dimensions of a locomotive are known and the boiler pressure is given, the tractive effort can be calculated (see formula in article on "The Frictional Limit" in the January, 1903, issue of RAILWAY AND LOCOMOTIVE ENGINEERING, page 20). The cut-off, when early, reduces the mean effective pressure in the cylinders; when late, the M. E. P. becomes greater, but the mean effective pressure is one of the factors you must deal with, and this may vary with any given cut-off, as the boiler pressure is high or low. If you have the M. E. P. and the diameter and stroke of the cylinders and the diameter of the driving wheels you can calculate the tractive effort of the engine. The master mechanics' formula for tractive effort assumes that the M. E. P. is 85 per cent. of the boiler pressure at slow starting speed with reverse lever in the corner. If you want to know, for example, what a 17x24 in. cylinder engine with 56 in. drivers and 180 lbs. boiler pressure can pull at 35 miles per hour, you may assume that the cut-off will be at $\frac{1}{4}$ stroke and the M. E. P. as given by Molesworth for that cut-off is 40 per cent. of the boiler pressure. The formula would then be as follows, $\frac{17^2 \times 24 \times 27}{56} =$ tractive effort.

In the May issue of RAILWAY AND LOCOMOTIVE ENGINEERING, page 215, you will find in answer to question No.

35 a table by which you may find the mean effective pressure for any cut off.

(58) Reader, Armona, Cal., writes:

(1) In your May issue you illustrate an Atlantic type and a Pacific type engine. Both these engines have outside journals on the trailing truck and what appears to be a flat frame on the outside of the wheel. Is this trailing truck frame separate from the main frame? A.—Yes, it is separate in the sense that it is usually a slab frame for outside journals and a bar frame for inside journals, but in any case the truck frame is rigidly and strongly bolted to the main frame, and is as much a part of the engine frame as the frame front to which the cylinders are attached. This style of frame would be all right with an oil burner, especially with outside journals on the carrying wheels. (2) How does a traction increaser work? A.—It puts weight on the driving wheels and takes weight off the engine truck and the carrying wheels. Read article which appeared in RAILWAY AND LOCOMOTIVE ENGINEERING, on page 247, of the June, 1902, issue. (3) The Santa Fe 2-10-2 compounds are called Vauclain Tandems. What is a Vauclain Tandem compound? A.—The name is derived from that of the superintendent of the Baldwin Locomotive Works of Philadelphia. Mr. Samuel M. Vauclain is the gentleman from whom the name of the compounds built at the Baldwin shops is derived.

(59) J. D. K., Temple, Texas, writes:

(1) How should I block an engine for a broken main tire? A.—Some writers on this subject advise the raising and blocking of the wheel to clear the rail on the disabled side and allowing the rods to remain intact. This is bad practice. With a broken or loose tire on one side, the opposite wheel should also be blocked. If it is a main driving wheel tire, all rods should come down; if any other wheel, the section of rod that controls that wheel should come down on both sides of the engine. This precaution is necessary to prevent the wheel from revolving and throwing the broken or loose tire, and from doing further damage. (2) When is a driving wheel out of commission? A.—Simply removing the rods that control one particular pair of wheels does not put them out of commission. They must be clear of the rails also, so that they can not revolve.

(60) F. C. B., Cedar Rapids, Ia., writes:

Two engines built by different builders and, to the best of my knowledge, from the same design are not giving the same results. One of them is a much stronger working engine than the other, but a much harder riding en-

gine. To overcome this trouble the company has added 237 pounds more counterbalance to the main driving wheels and the engineer claims that she rides much better. Is not this method of remedying the trouble wrong? A.—If both makers built from the same specifications, there is no reason why both engines should not ride equally well, and the fact that one of them does ride well would indicate that the original counterbalance weight is correct from one point of view, but wrong from another. If the hard riding engine is a more powerful engine and the increase of counterbalance has removed the trouble, then the counterbalance in the other would be wrong, if she exerted the same power, which you say she does not. Both can not be right in this case, and the better plan would have been to ascertain the travel and position of the valves. If your statement is correct, somebody has made a mistake, either in the proper amount of counterbalance or in the setting of the valves.

G. A. R. Encampment in Boston, August 15 to 20.

Ten years ago historic old Boston welcomed the Grand Army of the Republic, and the reception which New England tendered the "Vets" has long been remembered.

In ten years many changes have taken place in the ranks of these sturdy soldiers; but they are still ready for duty; and at the annual encampment in Boston this year, August 15 to 20, it is anticipated that over 100,000 people will visit the city, and over forty thousand will be in parade. Boston is an ideal convention city. Hotel proprietors, citizens and boarding house keepers all unite in doing their utmost for the ease and comfort of the visitors. As a city of interest Boston is without an equal; the many famous landmarks, historical buildings and places in Boston and the suburbs, make it doubly attractive as a convention city. Low rates from all sections of the country will apply, and to further aid the visitor, the Boston & Maine has recently published a delightful booklet which tells all about the encampment, and contains illustrations of the numerous historic landmarks and monuments in Boston and suburbs. The outside cover of the booklet is in three colors, showing an exact reproduction in colors of the official G. A. R. badge. This booklet is invaluable as a guide, and makes an interesting souvenir. Just send a postal card to the General Passenger Department, Boston & Maine Railroad, Boston, and the booklet will be mailed you free.

We must fight our way onward. We must be brave. There are obstacles to be met, and we must meet and crush them.

Names on Our New Transparency.

The reduced cut of our new transparency of an Atlantic type locomotive, which appears on page 345, is intended to mark the progress made in locomotive engineering since our Educational Chart No. 2 was first published, ten years ago. This forms our Educational Chart No. 7, and we trust it may prove as helpful to people interested in the locomotive as our old chart has been. The full size of the new chart is four inches longer than the old one, and the names of parts are a little fuller. The chart is sent by mail in a tube on receipt of 25 cents. It will be sent to all new subscriptions and renewals of old ones.

The names of parts indicated by the numbers are:

1. Pilot.
2. Coupler.
3. Coupler Knuckle.
4. Brake Train Line Hose.
5. Air Signal Line Hose.
6. Pilot Step.
7. Pilot Brace.
8. Pilot Cross Braces.
9. Coupler Brace.
10. Uncoupling Attachment.
11. Buffer Beam.
12. Front Foot Plate Step.
- 12A. Side Smoke Box Step.
- 12B. Running Board Brackets.
13. Cinder Chute.
14. Extension Smoke Box.
15. Signal Lamp Bracket.
16. Hand Hold.
17. Number Plate.
18. Smoke Box Door.
19. Front Hand Rail.
20. Front Smoke Box Step.
21. Headlamp.
22. Smoke Box Cleaning Hand Hole.
23. Smoke Box Netting.
- 23A. Diaphragm.
24. Exhaust Pipe.
25. Exhaust Nozzle Tip.
26. Blower Pipe.
- 26A. Blower Pipe Valve.
27. Steam Pipe.
28. T or Nigger Head.
29. Dry Pipe Joint.
30. Petticoat or Draft Pipe.
31. Smoke Stack.
32. Hand Rail.
33. Cylinder Saddle.
34. Piston Valve Bushing.
35. Valve Chamber or Steam Chest.
36. Steam Passage to Valve.
37. Back Steam Port.
38. Front Steam Port.
39. Steam Chest Cover.
40. Valve Stem.
41. Inside Admission Piston Valve.
42. Piston Valve Packing Rings.
43. Cylinder.
44. Piston Rod.
- 44A. Piston Rod Nut.
45. Piston.
46. Piston Packing Rings.
47. Cylinder Cocks.
48. Main Pilot Stay.
49. Cylinder Cock Rigging.
50. Engine Truck Cradle.
51. Engine Truck Equalizer.
52. Engine Truck Spring Band.
- 52A. Engine Truck Spring Hanger.
53. Engine Truck Casting.
54. Engine Truck Brake Rod.
55. Engine Truck Brake Lever.
56. Engine Truck Frame.
57. Engine Truck Brake Heads.
58. Engine Truck Tire.
59. Engine Truck Pedestal.
- 59A. Engine Truck Pedestal Binder.
60. Engine Truck Axle.
61. Engine Truck Brass.
62. Engine Truck Cylinder Brake Lever.
63. Engine Truck Brake Cylinder.
64. Crosshead.
- 64A. Crosshead Key.
- 64B. Wrist Pin.
65. Crosshead Gibs.
66. Guides.
67. Driving Brake Cylinder.
68. Frame Front.
69. Guide Yoke.
70. Main Rod.
71. Valve Rod Guide.
72. Valve Stem.
73. Valve Rod.
74. Rocker.
75. Rocker Shaft.
76. Rocker Box Casting.
77. Lower Cylinder Cock Lever.
78. Upper Cylinder Cock Lever.
79. Air Brake Train Line Pipe.
80. Air Signal Line Pipe.
81. Cylinder Cock Rod.
82. Driver Brake Cylinder Pipe.
83. Automatic Reducing Valve.
84. Engine Truck Brake Cylinder Pipe.
85. Driver Brake Lever.
86. Transmission Bar.
- 86A. Transmission Bar Hanger.
87. Sand Pipe.
88. Brake Cylinder Pipe.
89. Expansion Connection for Automatic Reducing Valve.
90. Brake Cylinder Pipe.
91. Boiler Tubes.
92. Cylinder Lubricator Pipe.
93. Step for Sand Box.
94. Sand Pipe.
95. Sand Box Trap.
96. Sand Box Lever.
97. Sand Box.
98. Sand Box Rod.
99. Front Boiler Stays.
100. Throttle Stand Pipe.
101. Driving Spring Hangers.
- 101A. Equalizer Hanger Gibs.
- 101B. Rear Truck Hangers.
102. Driving Springs.
- 102A. Trailing Truck Spring.
103. Driving Spring Band.
- 103A. Driving Box Saddle.
104. Driving Axle.
105. Counterbalance Weights.
106. Driving Tires.
107. Main Frame.
- 107A. Pedestal Binder.

- | | | |
|--|---|-----------------------------------|
| 107B. Trailing Truck Pedestal Binder. | 151. Hangers for Injector Delivery Pipe. | 186. Injector Overflow Pipe. |
| 108. Side Rod Crank Pin. | 152. Main Driver Brake Head and Shoe. | 187. Trailing Wheel Brake Rod. |
| 109. Side Rod. | 153. Rear Driver Brake Lever. | 188. Cab Ventilator. |
| 110. Adjusting Sleeve on Forward Driver Brake Rod. | 153A. Rear Driver Brake Equalizing Lever. | 189. Cab. |
| 111. Forward Driver Brake Rod. | 154. Spring Equalizers. | 190. Rear Boiler Braces. |
| 112. Driver Brake Lever. | 154A. Equalizer Fulcrum Brackets. | 191. Damper Rod. |
| 112A. Forward Driver Brake Equalizing Lever. | 155. Ash Pan. | 191A. Damper Connection Rod |
| 113. Forward Driver Brake Head and Shoe. | 156. Trailing Truck Axle. | 191B. Rear Damper Bell-Crank. |
| 114. Driving Spring Equalizer. | 156A. Retaining Ring. | 191C. Intermediate Damper Lever. |
| 115. Truck Brake Auxiliary Reservoir. | 157. Grate Bars. | 191D. Forward Damper Bell-Crank. |
| 116. Triple Valve. | 158. Grate Bar Arms. | 192. Air Pump Strainer. |
| 117. Driver Auxiliary Reservoir. | 159. Drop Grate Arm. | 192A. Air Pump Suction Valves. |
| 118. Air Train Pipe Strainer. | 160. Grate Bar Rest. | 192B. Air Pump Delivery Valves. |
| 119. Reverse Lever Counterbalance Spring. | 161. Shaker Rods. | 192C. Air Pump Delivery Pipe. |
| 120. Shifting Link. | 162. Air Signal Whistle Valve. | 193. Engine Step. |
| 120A. Link Block. | 162A. Air Signal Whistle. | 194. Radial Truck Swing Pin. |
| 121. Eccentric Rods. | 162B. Air Signal Whistle Pipe. | 195. Sight Feed Lubricator. |
| 122. Equalizer Safety Hangers. | 162C. Air Signal Reducing Valve. | 196. Injector Check. |
| 123. Rear Driver Brake Rod. | 163. Cylinder Cock Lever. | 197. Crown Sheet. |
| 124. Eccentric Strap. | 164. Reverse Lever Sector. | 197A. Back Tube Sheet. |
| 124A. Eccentric Strap Bolt. | 165. Reverse Lever. | 197B. Front Tube Sheet. |
| 125. Eccentric Rod Bolts. | 165A. Reverse Lever Latch Handle. | 198. Fire Box Door. |
| | 165B. Reverse Lever Latch. | 199. Engineers' Valve Train Pipe. |
| | 166. Engineers' Brake Valve. | 200. Main Reservoir Pipe. |
| | 167. Injector. | 201. Mud Rings. |
| | | 202. Grate Shaker Lever. |



TEN WHEEL ENGINE FOR THE TORONTO, HAMILTON & BUFFALO RAILWAY

- | | | |
|------------------------------------|---|----------------------------|
| 126. Main Crank Pin. | 168. Main Reservoir. | 203. Gauge Cocks. |
| 127. Back End of Main Rod. | 169. Brake Valve Reservoir. | 204. Crown Stays. |
| 128. Eccentric. | 170. Injector Steam Valve. | 204A. Crown Sling Stays. |
| 129. Driving Wheel Center. | 170A. Fountain Steam Valve. | 204B. Crown Flexible Stay. |
| 130. Boiler Cleaning Holes. | 171. Gauge Lamp. | 205. Expansion Pads. |
| 131. Link Hanger. | 172. Lubricator Steam Valve. | 206. Boiler Waist Brace. |
| 132. Reverse Shaft Arm. | 173. Water Gauge. | 207. Fire Box. |
| 133. Reach Rod Arm. | 174. Air Pump. | 208. Dry Pipe. |
| 134. Reach Rod. | 174A. Air Pump Exhaust Pipe. | |
| 135. Throttle Box. | 174B. Air Pump Head. | |
| 136. Throttle Valve. | 174C. Air Pump Piston Rod. | |
| 137. Dome Ring. | 175. Air Pump Duplex Governor. | |
| 138. Dome Cap. | 176. Air Pump Steam Pipe. | |
| 139. Dome Casing. | 176A. Air Pump Steam Throttle Valve. | |
| 140. Throttle Stem. | 177. Air Signal Line Hose. | |
| 141. Fountain Dry Pipe. | 178. Brake Train Line Hose. | |
| 142. Safety Valve. | 179. Cab Hand Rail. | |
| 143. Chime Whistle. | 180. Apron. | |
| 144. Stop for Throttle Bell-Crank. | 181. Injector Feed Pipe Coupling Nut. | |
| 145. Throttle Bell-Crank. | 181A. Injector Feed Pipe. | |
| 146. Throttle Rod. | 182. Buffer Casting. | |
| 147. Bell Frame. | 183. Trailing Truck Wheel Center. | |
| 148. Bell. | 184. Trailing Truck Wheel Tire. | |
| 149. Bell Rope Arm. | 185. Trailing Truck Brake Lever and Shoe. | |
| 150. Injector Delivery Pipe. | | |

Ten Wheel Engine for the T., H. & B.

The Toronto, Hamilton & Buffalo Railway have recently purchased from the Locomotive and Machine Company of Montreal, some ten wheel passenger power. The builders are now the Canadian branch of the American Locomotive Works and Mr. J. Christopher is the master mechanic for the road.

The engine is simple with 19x26 ins. cylinders and 60 in. driving wheels. The main drivers, which are the center pair, are without flanges. The driving wheel base is 14 ft. and the total wheel base measures 24 ft. 7 ins. The weight

of the engine in working order is 140,000 lbs. The adhesive weight, or that carried by the drivers, is 107,000 lbs. and the weight of the whole machine, with the tender, is 245,000 lbs. The valve motion is indirect and the valves are the Richardson balanced, with a travel of 6 ins.

The boiler is an extension wagon top, 62 ins. diameter at the smoke box end, with the gusset sheet in the second course. The crown sheet is level and there is about 20 ins. of steam space between it and the roof sheet, which is also level. The fire box is 41 ins. wide, which brings the side sheets just beyond the outside of the frames. The heating surface is in all 2,165 sq. ft., which is made up of 2,040 sq. ft. in the tubes and 125 sq. ft. in the fire box. The grate area is 27.33 sq. ft. and the steam pressure carried is 200 lbs.

The tender is of the usual pattern, with 10 in. steel channel frames. The trucks are of the diamond arch bar type with cast steel bolsters. The tank holds 5,000 U. S. gallons of water and the coal capacity is 9 tons. The wheel base of engine and tender is 51 ft. 7½ ins. A few of the principal dimensions are appended for reference:

Cylinders—19 x 26 ins.; size of steam ports, 18 ins. x 1½ ins.; size of exhaust ports, 18 ins. x 3 ins.; size of bridges, 1¼ ins.

Valves—Outside lap of slide valves, 1 in.; inside lap of slide valves, 0 in.; lead of valves in full gear, 0 in.

Wheels, etc.—Engine truck, journals, 5½ ins. dia. x 10 ins.; dia. of engine truck wheels, 30 ins.

Boiler—Thickness of plates in barrel and outside of fire box, ¾ in.; fire box, length, 96 ins.; fire box, width, 41 ins.; fire box, depth, front, 75 ins.; back, 69 ins.; fire box plates, thickness, sides, ¾ in.; back, ¾ in.; tube sheet, ½ in.; fire box, water space, front, 4 ins.; sides, 3½ ins.; back, 3½ ins.; fire box, crown staying, radial stays; tubes, number, 279; tubes, dia., 2 ins.; length over tube sheets, 168 ins.; boiler supplied by two No. 9 Monitor injectors.

Tender—Weight, empty, 42,000 lbs.; wheels, dia., 33 ins.; journals, dia. and length, 5 ins. dia. x 9 ins.; wheel base, 17 ft. 4½ ins.

S. S. Baltic.

The new White Star Steamship *Baltic*, which made its first trip across the Atlantic last month, is the largest vessel afloat. She is 725 ft. 9 ins. long, 75 ft. beam, and 49 ft. deep. Her cargo capacity is 28,000 tons. Of course the interesting thing is her engines, and it must be remembered the object which the designer of the ship had was not to push her through the water at top speed but to produce a ship which would carry comfortably somewhere about 3,000 passengers at the moderate speed of about 17 knots. The ship was built by Harland and Wolff, of Belfast, Ireland.

There are two engines, as she is a twin screw steamer, and each is a quadruple expansion engine. The high pressure cylinder is 33 ins. in diameter, the next is 47½ ins., the next 68½ ins., and the largest is 98 ins. The stroke of

all is 63 ins. When at sea the engine runs at a speed of about 78 revolutions per minute with steam pressure of 220 lbs.

The balancing is on what is called the Yarrow-Schlick-Tweedwy system, and this plan consists not of putting the cranks at right angles to each other as is done on a locomotive, but the cranks are set at odd angles, the particular position of each has been predetermined so as to give the very best results as far as the reduction of vibration is concerned. The two surface condensers have a total cooling surface of 18,000 sq. ft. and the air pump is driven direct from the crossheads of the first intermediate cylinder.

The boilers are eight double end marine boilers made of 1½ in. plates. They are each 19 ft. 6 ins. long and 15 ft. 6 ins. in diameter. There are six furnaces to each boiler, three at each end, and a common combustion chamber in the center of each boiler from which the flues pass to both boiler heads. There are, therefore, what we would call 48 fire boxes to supply with coal. The total grate area of all these furnaces is 1,008 sq. ft. and the total heating surface in the eight boilers is 41,680 sq. ft.

An acre contains 43,560 sq. ft. and when in the form of a square has each

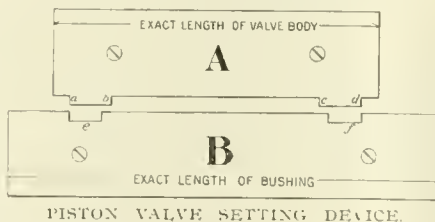

of its sides measuring very nearly 200 ft. The heating surface of the *Baltic* boilers is to be exact in just .95 of an acre. Last March we had occasion to point out that the heating surface of some Baldwin 2-8-2 engines for the Santa Fe had each 5,366 sq. ft. of heating surface, which is very nearly the area of the circle swept out by two 60 ft. turntables and that some Decapods for the same road had each 5,390 sq. ft. of heating surface. These decapods had, therefore, as heating surface an area just a little less than that of two tennis courts. The boilers of the *Baltic* have, therefore, a total heating surface equivalent to that contained in something more than 7 Santa Fe decapods.

Device to Assist in Setting Piston Valves.

Reading Mr. Ira A. Moore's communication to RAILWAY AND LOCOMOTIVE ENGINEERING, March, 1904, page 104, on "Setting Inside Admission Piston Valves," the question suggested itself, Why not use a duplicate or "dummy" for this purpose? The apparatus need not be of a very elaborate nature. Cut

two pieces of ⅝ in. sheet iron, as shown in the sketch, the corners, *a, b, c, d*, of projections on piece *A* being coincident with steam and exhaust edges of piston valve packing rings, the notches in piece *B* with steam ports in valve bushing, success depending in a large measure upon the accuracy with which this part of the work is done. Screw these pieces to two pieces of 1 in. lumber having the edges planed square to form a slide. Attach *A* to piston valve stem extension by light rod and suitable clip, and *B* to cylinder stud or adjacent part of framing by light bracket, and adjust relative to ports in exactly the same position as piston valve to be adjusted, and proceed to set valve in the usual manner, and not only can all measurements be easily and accurately made, but the action of the valve throughout the stroke can be noted. When the job is completed put the "dummy" valve where it can be readily found until another similar valve requires adjusting.

It will be easily seen that the "dummy" is applicable to piston valves of all descriptions and where standards are maintained once a set is made they remain good for all time.

J. F. GREIG.

Palmerston-North.

Frauds Using Name of Firemen's Brotherhood.

The National Brotherhood of Locomotive Firemen will meet in Buffalo in September, and the committees are now at work securing the necessary funds for the entertainment of the delegates. They wish to warn business men and merchants that a number of fakirs are taking advantage of this fact and trying to raise money, pretending that it is for the Locomotive Firemen's convention, whereas it is simply for their own use. No merchant or business man should subscribe, give money or advertising to any solicitor unless he can show proper credentials from some official source or from Curt M. Treat, of the Convention Bureau of the Chamber of Commerce.

The latest air brake instruction book on the market is "Modern Air Brake Practice—Its Use and Abuse," by Frank H. Dukessmith. The author endeavors to place the subject more plainly before the air brake students than he believes is done in books already published. He has divided the work into three parts. The first part treats of the mechanism and of the duties of its parts. The second explains the various defects of the equipment and their remedies. His third section is devoted to "The Philosophy of Air Brake Handling," which head is usually known as practical road work. He treats the subject of air brakes for electric cars in a limited way. A good index concludes the work. Price, \$1.50.

Air Brake Department.

CONDUCTED BY F. M. NELLIS.

Automatic Valve Handle Returning Device.

Considerable difficulty has been experienced in past years from overcharging the train pipe and auxiliary reservoirs by the leaving of the brake valve handle in full release position, or failure to return it at the proper time to run-

ning position after the maximum train line pressure of 70 lbs. has been accumulated. We illustrate that device herewith.

Fig. 1 is a plan, or downward view of the motorman's brake valve, equipped with Mr. Gottschalk's device. Fig. 2 is a side elevation, or view, of the same valve. Figs. 1 and 2 serve to show the general arrangement of this attachment, which consists generally of a center piece, or attachment, placed between the feed valve attachment and the valve body. Fig. 3 shows the center piece mounted on the slide valve feed valve attachment. Fig. 4 shows a sectional view of this center piece, which consists of a cylinder, a piston with a hooked end for engaging the brake valve handle, and the other usual accessories. The operation of the device is briefly as follows:

When main reservoir air is passing back into the train pipe, valve *v* (Fig. 3) is forced from its seat *s* by the spring *t*, and the main reservoir air passes through port *c* (Figs. 3 and 4) to the

train pipe, connection is had through ports *a* and *c* to the piston *P*, holding the spring compressed and the piston shoved out. When the slide valve returns to closed position, as shown in Fig. 7, port *a* in the slide valve is inoperative, while cavity *b* in the face of

of the pin-valve attachment shown in Fig. 3. Fig. 7 shows a different arrangement whereby the device may accomplish the same work by coring out the feed valve body casting, which, for this device, may be made heavier. Fig. 8 shows a top view of the slide valve feed valve with suitable ports drilled

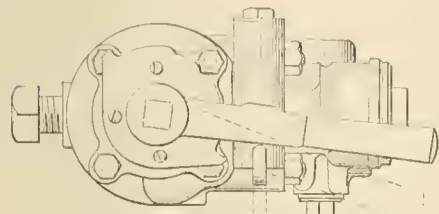

Fig. 1 Reg. U. S. Pat. Off.

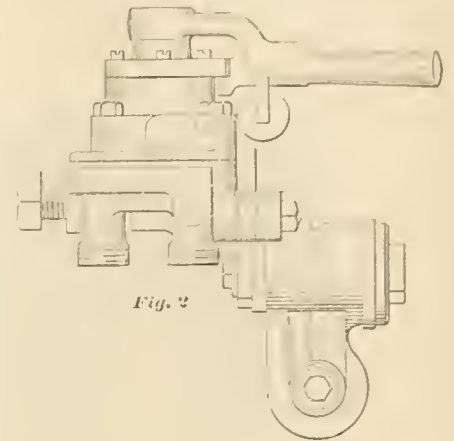

Fig. 2

Reg. U. S. Pat. Off.



Fig. 5



Fig. 6

Reg. U. S. Pat. Off.

therein to accomplish this purpose. When main reservoir air is passing to the train pipe, connection is had through ports *a* and *c* to the piston *P*, holding the spring compressed and the piston shoved out. When the slide valve returns to closed position, as shown in Fig. 7, port *a* in the slide valve is inoperative, while cavity *b* in the face of

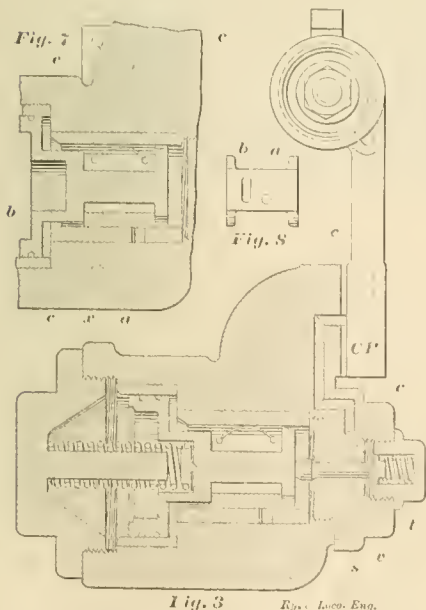

Fig. 3 Reg. U. S. Pat. Off.

pressure end of the piston *P* (Fig. 4), compressing the spring and forcing the piston upward. When 70 lbs. pressure has been accumulated in the train line, the feed valve attachment shuts off, in the ordinary way, pressure passing to the train pipe, and moves to the closed position, as shown in Fig. 3. In this position the feed valve attachment piston seats the valve *v* on its seat *s*, shutting off main reservoir pressure to the small cylinder *C* (Fig. 4). The pressure remaining in port *c* and in the pressure end of the cylinder *C*, discharges to the atmosphere at port *x* (Fig. 3), thus permitting the spring *s* (Fig. 4), to force the piston *P* to the position shown in Fig. 4, the hooked end *H* of the piston engaging the brake valve handle and pulling it to running position, thus automatically closing off the direct entrance of main reservoir air to the train line.

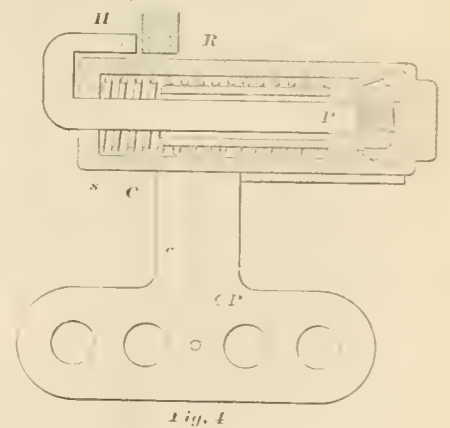

Fig. 4

the slide valve engages port *c* and port *x*, thus venting the pressure from port *c* and the pressure end of the cylinder *C*.

This device has been in service for several months on the Manhattan Elevated Railroad, New York City, and performs its work perfectly in accordance with the design of the inventor.

Mr. A. Gottschalk, foreman of air brake work on the Manhattan Elevated Railroad, New York City, has invented a device for automatically returning the handle of the motorman's brake valve

New Triple Valve Testing Machine.

We illustrate herewith the improved triple valve testing device, as recently perfected by the Westinghouse Air Brake Co. Fig. 1 shows the general arrangement of the machine when testing a quick action triple valve. Fig. 2 shows the same machine, using modified connections in testing the plain triple valve. These tests are substantially the same as those on the older machine with the exception that improvements have been made in the controlling valve, piping arrangements, clamping arrangements and in the differential pressure valve K.

Fig. 3 is a clearer illustration of some of these improved features and shows the quick action triple valve attached to the triple valve stand. The clamp-

however, is the differential valve K as will be seen. Valve K is now mounted on the top of a two-way cock, and when the handle is turned to the right, as in the illustration, the sensitiveness of the piston and slide valve may be tested when releasing. With the handle turned to the left, the sensitiveness of these parts is tested in application; that is, the repaired triple valves are now tested for sensitiveness in both application and in release.

A strainer is now supplied to protect the controlling valve under the bench from moisture and other foreign substance. The top of the bench is fitted with a steel plate in which openings are made to receive the flanges of the triple valve, thereby providing a vise arrangement for holding the triple by

of. This is a most important subject; for, no matter how well the remainder of the brake apparatus is maintained, if the brake cylinder leaks the brake is inefficient.

The pump is the beginning of the brake system and, so far as the air pressure is concerned, the brake cylinder is the end. Driver and tender brakes are daily where they can be tested and repaired, yet brake cylinder leakage is probably the most common and the most serious defect, at least with the former. Some roads provide a plugged tee by which a test gauge can easily and quickly be attached, an excellent provision that should be universal.

But, as Mr. Howarth says, the car brake has no convenient means for using a gauge. With the large number of such

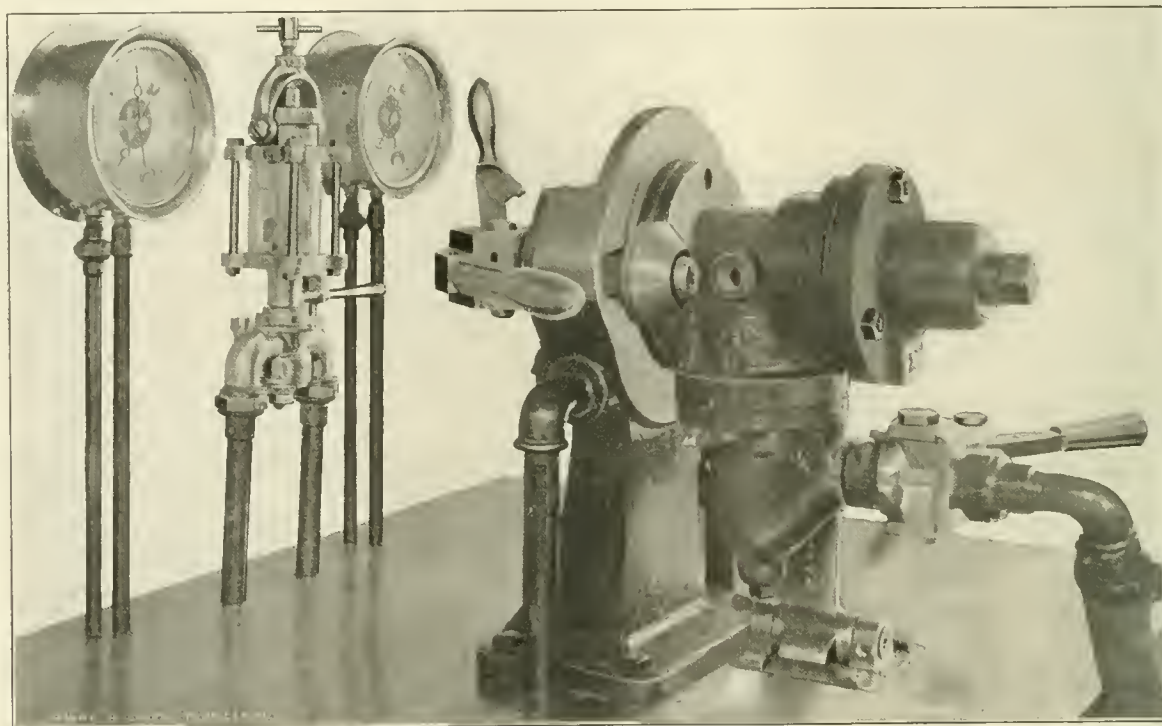

NEW TRIPLE VALVE TESTING MACHINE. VIEW SHOWING QUICK CLAMPING DEVICES AND NEW VALVE "K."

ing arrangement which fastens the valve to its stand consists of two eccentric handles working in horizontal plane and otherwise similar to those on the older machine which worked in a vertical plane. The hose is also attached to the triple by a quick clamping device, instead of being screwed on with a wrench. It will be also observed that the arrangement for correctly and accurately placing the piston and slide valve of the triple at lap position, for the packing ring test, is made much simpler and better. By special arrangement, on this attachment, any of the triple valves may be placed at lap position accurately and correctly by merely turning a connection on the stem for that certain triple valve. The greater improvement in this device,

merely placing it on the bench. Suitable pins are also supplied in this plate which will hold the triple valve body clamped when any of the machined faces are turned downward, thus making a universal vise for holding the triple valve in any position without the usual movements required in a vise.

Correspondence.

Brake Cylinder Leakage.

In the March number Mr. H. B. Howarth calls attention to the need of testing car brake cylinders and retaining valves for leakage, suggests connecting a gauge at the retaining valve pipe union and asks whether any better method is known

brakes to be cared for, it is questionable whether the use of a gauge would be practicable. With the object of surmounting this difficulty the writer once made some tests, hereafter described, which it is believed offer a simple and sufficiently accurate solution of the problem. While it is probable that the tests should be repeated under slightly different conditions, yet the method of making them is so simple and the results so important as to amply warrant doing so.

Eight different cars were tested, five being ore cars and two box cars. A very considerable difference in leverage and rigging was comprehended in the tests. A gauge was connected directly to the brake cylinder, the retaining valve was cut in, handle horizontal, the brake valve was applied in emergency and re-

charged a couple of times so as to take up all lost motion and then a service application sufficient to run the cylinder pressure above 60 lbs. was made. A rule was then held on the piston rod, the triple valve was released and, by controlling the retaining position exhaust port with one's thumb, the cylinder pres-

a short equalizing lever having its ends connected directly with the live levers. This is a type of rigging much used with the early freight car air brakes. Box car 9476 was like 4705 except that the rigging had 1 in. levers and National Hollow brake beams. The remainder were ore cars with varying leverage.

In view of the fact that it may not generally be to charge the auxiliary reservoirs to 80 lbs., it is quite possible the tests had better be made from a maximum cylinder pressure of 50 lbs. However, this can be made to suit existing conditions.

In these tests it was observed that a good holding retaining valve would not permit of moving the brake shoes on the wheels by a strong push with one's foot on the end of a brake beam, selecting one of the latter that did not have the shoe on that side against the wheel flange.

It is believed best not to break the retaining valve pipe union joint, where otherwise unnecessary, except it is leaky, as a tight one somewhat corroded generally holds best.

The most common neglect is failure to securely clamp the retaining valve pipe so as to absolutely guard against vibration when the car is running. This can be tested with one's hand and the test will often indicate a loose joint or fractured pipe. A vibrating pipe will soon loosen well made joints and occasionally break the pipe where it connects with the triple valve.

It should be understood that the direction and clamping of the pipe near the triple valve should provide some flexibility so as to guard against breakage if the cylinder and reservoir become a little loose on the car.

F. B. FARMER.

St. Paul, Minn.

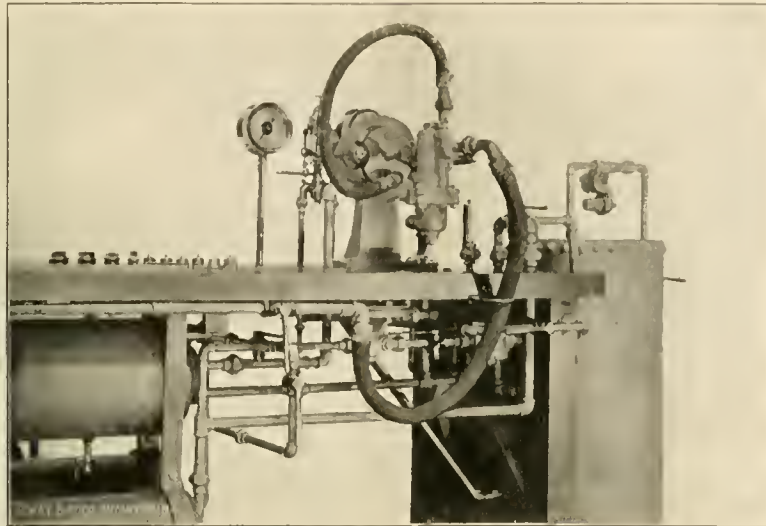

NEW TRIPLE VALVE TESTING MACHINE, PLAIN TRIPLE ON STAND.

sure was allowed to fall to exactly 60 lbs. The piston travel was then noted and recorded and the pressure was again allowed to discharge slowly until the piston rod had moved back $\frac{1}{4}$ in., when the discharge was again stopped until the loss in cylinder pressure had been noted. The next gauge reading was made with a total of $\frac{1}{2}$ in. reduction in piston travel, then $\frac{3}{4}$ in. and finally with one inch. As the latter left the shoes slack on the wheels, it indicates that when the piston has leaked back one inch the brake is practically off so far as holding power is concerned. This test was immediately repeated twice, a total of three, and then averaged. The box and ore cars were tested at different times and not with the same gauge. Owing to this and less care being taken at the start it is believed that farther and more careful tests would show even more uniform results, particularly if confined to modern freight cars. The tabulated results are as follows:

Car No.	Travel at 60 lbs.	Pressure Loss for Travel Reduction of			
		$\frac{1}{4}$ in.	$\frac{1}{2}$ in.	$\frac{3}{4}$ in.	1 in.
4705	6 $\frac{1}{4}$	20	32	38	43
3611	6	19	28	38	44
9476	5 $\frac{1}{2}$	24	41	48	52
6542	7 $\frac{1}{8}$	26	40	50	55
1308	6 $\frac{1}{2}$	27	38	45	51
1175	7 $\frac{3}{4}$	29	41	50	54
1179	6	22	34	43	50
1474	6	18	28	38	45
Average Loss		23	35	44	48

Box car 4705 had the Westinghouse standard quick action brake, M. C. B. standard type of rigging but with $\frac{3}{4}$ in. levers and trussed, wooden brake beams. Box car 3611 was similar except for a lower leverage and the push rod carried

These tests indicate that if a cylinder pressure of about 60 lbs. is had, $\frac{1}{4}$ in. reduction in piston travel by reason of leakage means a pressure loss of about 25 lbs., $\frac{1}{2}$ in. about 35 lbs., $\frac{3}{4}$ in. about 45 lbs., and 1 in. about 50 lbs.

The results sufficiently satisfied one road that they required the following test after cleaning and lubricating brakes. Charge the auxiliary reservoirs

Probably a Leaky Slide Valve.

With a triple valve of the F-27 type, the air leaks out of the exhaust port

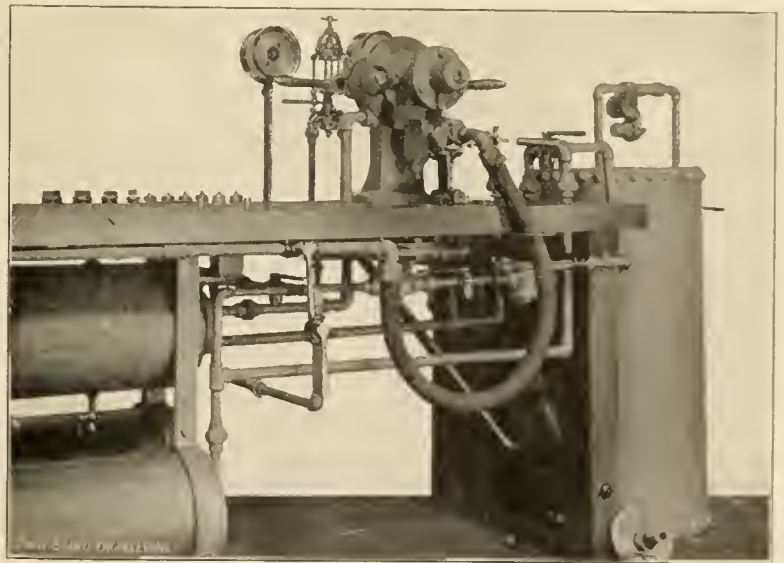

NEW TRIPLE VALVE TESTING MACHINE, QUICK ACTION, TRIPLE ON STAND.

to 80 lbs., make a full service application and quickly measure the piston travel. In three minutes measure again and if a loss of $\frac{1}{4}$ in. or more has taken place the work is not satisfactory and the cylinder leakage must be reduced.

when the valve is in release position, and also when it is set in either the service or emergency position, with the engineer's valve on lap.

I claim that if the slide valve would leak, or its seat was cut, by putting the

engineer's valve on the lap, the triple ought to go to the release position. But it does not, it stays set.

The valve will stand the test which we give; that is, set it through a diaphragm orifice of $\frac{1}{2}$ in. in the train line. After it is set in this manner, the train line is emptied and the engineer's valve is put in the running position and the train line is again charged to 70 lbs., which will release the brake.

Now, what I would like to know is this: Where does this leak come from? The valve has been cleaned, the gasket No. 14 is new; also the emergency valve No. 10 and rubber seat No. 11 are new. Seat No. 9 is new; also spring No. 12 is of the proper length, being $1\frac{3}{4}$ ins. long. The gasket No. 15 is good. I must state that this valve has been in service about 10 years on a baggage car next to the engine. Will you please oblige by stating what is the matter with this triple?

H. A. JOSEPH.

Chicago, Ill.

[If the leakage exists with the triple in full release, it is probably auxiliary reservoir air leaking out past the bad joint between the slide valve face and its seat with the triple in this particular position. When the leakage is experienced and the triple is in graduating or lap position, it is probable that the air coming out at the exhaust port is auxiliary reservoir air, being let out through another bad fit in that position between the slide valve face and its seat. In emergency application if this leakage still exists, it is probable that the leakage is made by air escaping from the auxiliary reservoir and brake cylinder combined, through a bad fit between the slide valve and its seat. It is reasonable to assume that the fit between the slide valve and its seat, and the fit of the piston packing ring in its bush are defective. It has been found that the releasing test for a triple valve, made through an orifice in the diaphragm placed in the train pipe, is not reliable. Recent tests have demonstrated, that the more reliable test is an arrangement whereby certain specified differential pressures may be maintained on the auxiliary reservoir and train line sides of the triple piston, and if then the brake does not release, the auxiliary reservoir will charge up through a by-pass port. This is the arrangement on the triple valve testing machines sent out by the Westinghouse Air Brake Company, being reliable and vastly superior to the diaphragm orifice plan. With the old plan of feed up test through a diaphragm orifice, the time of feed is erratic and unreliable under varying conditions. Ed.]

Proposed Combined Automatic and Straight Air Brake for Cars.

In view of the success of the combined "automatic straight air" brake on engines and tenders, why couldn't an arrangement be made whereby the straight air could be used on a freight train on mountain grades successfully?

I think it could be accomplished by the addition of a valve under each car and

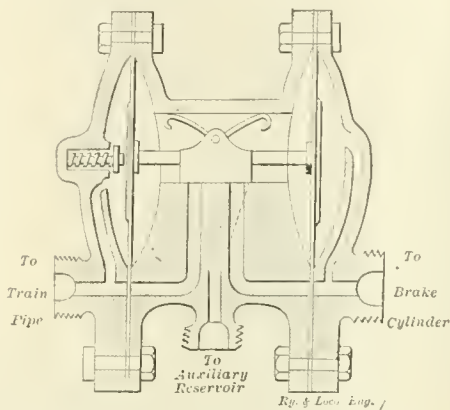

PROPOSED COMBINED AUTOMATIC AND STRAIGHT AIR BRAKE VALVE FOR CARS.

an additional port drilled in the rotary seat of the brake valve, near the feed port i.

The drawing herewith, Fig. I, represents a slide valve, similar to that in the triple valve, actuated by a rod attached to both plates, and rubber diaphragms, similar to the train signal valve, and a spring strong enough to hold the valve to its seat. The movement of this slide valve and diaphragms should be merely enough to uncover and cover the ports in the slide valve seat.

With air in the train pipe, the slide valve will be in position shown in Fig.

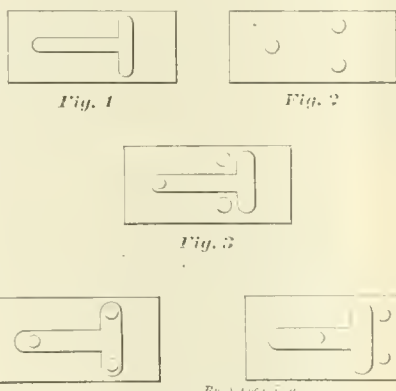

PROPOSED COMBINED AUTOMATIC AND STRAIGHT AIR BRAKE FOR CARS.

II. The train pipe pressure acting on the outside of the left hand diaphragm will hold it in this position.

After a full service application, or when the brake cylinder pressure becomes slightly stronger than that in the train pipe, the pressure acting upon the slightly larger diaphragm to the right, Fig. I, will force the slide valve to the position shown in Fig. III, thus establish-

ing a direct communication between the train line, brake cylinder and auxiliary reservoir. The brake valve handle can then be dropped back on the shoulder between running and lap positions, thus feeding a small amount of air from the main reservoir to the brake cylinder. This would supply train pipe leakage, also slight leakage past the packing leathers or in pipe connections.

If the leakage past leathers, or out of pipe joints is greater than the supply, the valve will, of course, assume position shown in Fig. II, and avoid the waste of air trying to operate a defective brake.

If the supply through the port in the brake valve is inadequate, the handle can be dropped back a little farther, partly uncovering the feed port. The black hand on the gauge will, of course, register brake cylinder pressure at this time.

If the train was left standing in this position, the feed valve would close communication between the reservoir, train line, and brake cylinders when pressure became equal to the tension of the feed valve spring, and, of course, supply it when pressure became weaker.

The object of the port to the auxiliary reservoir is to prevent the triple piston from going to release position when increasing brake cylinder pressure.

Brake cylinder pressure can be reduced by a series of very light reductions, not heavy enough to move the triple pistons, although the average train pipe leakage will take care of that.

In case of a burst hose, the brake cylinder pressure would act on the diaphragm on the right side of the cut (Fig. I), compress the small spring on the left hand side of the valve and diaphragm, and force the slide valve to position shown in Fig. IV, closing communication between the train pipe and the brake cylinder, and prevent air from escaping from cylinder to train pipe.

To release brakes, do it in the usual way. The valve will be forced to position, shown in Fig. II, as soon, or sooner than the triple piston can be moved, by admitting the entire main reservoir pressure to main pipe.

One car so equipped could not, in any way, interfere with the operation of the automatic brake, but to attempt to operate the straight air with but part of the train equipped, would result in releasing cars not so equipped, if triple piston packing rings were tight.

Either diaphragm of this valve bursting would render the valve inoperative, but would not interfere with the ordinary automatic brake. A leak between ports would cause blow at triple exhaust.

G. W. KIEHM, Air Brake Mchst.,
Pennsylvania R. R.
Washington, D. C.

Novel Use for Train Line Pressure.

An inventor who is anxious to prevent journal bearings being stolen has conceived the idea of using a hidden coil spring to hold the brasses in place against all comers. Each brass has a thickening piece cast on, ahead of the ordinary lug and in this a sort of oval hole is cored. The sides of the boxes are provided with two air cylinders each fitted with a piston. The piston rods extending outside the cylinders fit very loosely into the oval holes in each side of the brass. A coil spring at the back of each piston forces it out and keeps the piston rods in the oval holes in the brass. The brass while free to move on the journal is nevertheless retained in the box by this "air lock," and the brass thief would, therefore, be foiled in his wicked attempt to take what did not belong to him.

The car repairer who desires to remove a brass "for the good of the service," is able to do so by reason of the fact that he is supplied with an air connection which he attaches so as to connect train line and the axle box "air lock" piping. This connection having been made, air is introduced into the cylinder and the pistons forced back, the coil springs are compressed and the piston rods come out of the oval holes in the brass. If it is only necessary to jack up a box for any reason, the brass is raised at its front end, and remains suspended unless released by the introduction of air pressure.

This device affords a good example of the kind of ideas which are constantly worked out and sent to RAILWAY AND LOCOMOTIVE ENGINEERING for comment. While we have no desire to dampen the efforts of inventive genius we cannot help remarking that this is only one more of the many inventions which theoretically accomplish what the inventor desires, but which on account of the complications it introduces, the extra expense it involves, the maintenance charge which, however small, always follow from its adoption, must bar it out and make it practically an unusable device on railway axle boxes. The inventor has too much "machinery" for the value of the work done and though it would be quite possible to hold brasses as here described, it would not have the least chance of adoption when viewed from a commercial standpoint.

QUESTIONS AND ANSWERS ON THE AIR BRAKE.

(58) A. B., Armona, Cal., asks:

Why is the air pump being so generally placed on the left side of the engine? A.—Because some engineers object to having the air pump obstruct their forward view from the engineer's cab, and also because drippings from the piston rod and loose steam

pipe connections to the pump cause oil and water to be splashed onto the forward window of the cab, thus obstructing the engineer's view, especially in cold weather.

(59) A. B., Armona, Cal., asks:

What would be the result if port *c* in the pump governor is plugged up? A.—Port *c* is designed to allow air to escape from the top of the piston, after the diaphragm valve has become seated, due to the drop of air pressure, and allow the pump to start up again. Therefore, if this port were stopped up, the governor would be less sensitive in its operation, and would go to work slowly instead of quickly, as the air pressure on top of the piston would be obliged to leak downward and out through the drip waste pipe, 35. Port *c* should never be closed up.

(60) R. L. E., Grand Rapids, Mich., asks:

Would there be any bad effects from having lost motion in the brake valve handle of the engineers' brake valve, or in the handle bolt 9, or in the spring in the older pattern, or the brake valve handle being loosely or badly worn? A.—All of these conditions as cited would have a very bad effect, inasmuch that none of the positions on the brake valve could be relied upon unless carefully watched, and when the operation in one position was desired, the above discrepancies, any one of them, might be sufficiently bad to produce exactly the opposite to what was desired.

(61) A. B., Armona, Cal., asks:

What are the small holes around the lower valve cages in the air end of a 9½ in. pump for? and why are they not found in the upper cages of the air valves? A.—These small holes are for the purpose of admitting compressed air from the air cylinder to the under side of the discharge check valves. As will be noted by reference to the drawing of the pump, the only way to admit air to the under side of the lower check valves is by these small holes. The upper check valves do not need small holes in their cages, as there is a direct and large opening to the under side of those valves.

(62) R. L. E., Grand Rapids, Mich., asks:

Is it considered good practice, or permissible, to use brakes in emergency position at water plugs, platforms for baggage, milk cans, etc., on local passenger trains? A.—All of these practices are objectionable and can, therefore, be called poor practice. All these stops can be made by service applications by careful manipulation of the brakes, and especially, if the engine be equipped with the combined automatic and straight air brake, which permits of all brakes on the entire

train being applied, then the brakes on the engine released without interfering with the brakes on the cars of the train. The combined automatic and straight air brake is a great aid in making smooth stops without shock and jar at such places.

(63) R. L. E., Grand Rapids, Mich., asks:

What would happen if warning port R in the brake valve is stopped up and allowed to remain so? A.—In full release position there would be no warning to the engineer to return the valve handle to running position, and thus cut off the direct supply of main reservoir pressure to the train line. The train line and auxiliary reservoirs would be charged up to the full pressure by the main reservoir, thus producing slid flat wheels if the emergency application were made. Again, if the valve handle is allowed to remain in full release until the train line is charged to a pressure higher than the feed valve attachment is set for, and the handle then returned to running position, brakes would probably apply and stick.

(64) C. H. T., Mechanicsville, N. Y., asks:

Is that air in the triple valve which lies between the rubber seated valve and the non-return check valve disturbed in a service application? A.—No. It is not disturbed. To illustrate the case suppose, before the service application is made, that 70 lbs. pressure is held in the auxiliary reservoir and train line, then the pressure lying between the rubber seated valve and non-return check valve is also 70 pounds, minus the tension of the spring which holds the non-return check valve to its seat, which is about 1½ lbs. This gives 70 lbs. train line pressure and 68½ lbs. pressure lying between the rubber seated valve and the non-return check valve. If a service train line reduction is made, the non-return check valve prevents the air above that valve from reducing with the train line pressure, and, as there is no outlet for this air to the break cylinder, it must remain trapped, therefore, not being disturbed by the service train line reduction unless there is a leakage past the non-return check valve which permits the trapped air to flow back into the train line. As both this check valve and the rubber seated valve are supposed to be tight, there would be no disturbance of the air lying between the rubber seated valve and the non-return check valve in a service application.

The proceedings of the Buffalo convention of the Air Brake Association should be ready for mailing about August 15. These proceedings will be exceptionally interesting this year.

(Correspondence continued from page 357.) ing rail, but I do know that the left tires of the average locomotive flatten first, and I am sure it is done by the position in which the engineman works reverse lever. You may call it excessive lead, pre-admission, or high initial pressure, as you like, but it is the cause of the distortion on left side, but why on left side more than on right? I cannot say, but I have thought that if the left engine led the right one, the defect would be on the right side. It was my experience to use two different engineers on one and the same locomotive on the same run, same daily mileage, pulling the same or about the same tonnage. One of these men kept engine out for 16 months before tires had to be turned; the other man forced the engine in for some repairs in 5 months. On inquiry I found that there was a difference of two notches in quadrant, and the one who used the closest cut off was the one who flattened tires first. D. O. SMITH.

Jackson, Ala.

Mason Engines.

Referring to the Mason locomotive Saxon, in Mr. Sinclair's articles on the growth of the locomotive, the date of the Saxon is very much later than 1856, as its design shows. There were four of the Saxon class of engine on the Lake Shore & Michigan Southern Railway. The mate of the Saxon was the Norman and they ran between Elkhart and Chicago. Cylinders 17 ins. base and 24 ins. stroke, and had about a sixty-eight inch drive wheel over the tire. Boiler tapered from the roof or dome sheet forward, probably four inches smaller at the smoke box than at dome sheet. Then engines appeared about 1874, at a period just after the famous competition of the Lake Shore & Michigan Southern Railway and the New York Central Railway with the Pittsburg, Ft. Wayne & Chicago Railway and the Pennsylvania Railway for the profit and honor of carrying the through mails between Chicago and New York. The Vanderbilt lines won as they have often since by the merit of their low grades and the Pennsylvania lost as they have since by climbing the Alleghany mountains.

Another famous Mason engine of a little earlier period on the Lake Shore & Michigan Southern, was the Sam Brown, a 16x24 in. engine that made many notable runs in the racing for the fast mail and did much to win it. It was a very fine machine, handsome and symmetrical as all Mason engines were.

A feature that made Mason engines successful and popular was they had large fire boxes and the fire box door was very conveniently located, so they

were easy to fire and good steamers. Other makers located the door almost "any old place" in the boiler front, some so low that the deck had to be cut away to open door, and others very high and inconvenient in shape to handle wood through. Another feature, Mason made his engines accessible and convenient to repair and convenient to the engine crew, and for this thanks are due him even to this day,

I believe I am right in saying, there are more Mason engines in service to-day than any contemporaneous engines. The reason was their correct mechanical lines and splendid material in boilers and castings. The writer is conversant with many Mason engines thirty-three years old that are practically original in all their parts and doing daily service, and doing it well. I visited Mason's shop when the Janus, double ender, was under construction, then a very busy place with the engine building and cotton machinery production. Time cannot take away from



LOCOMOTIVE SAND HOIST.

Mason's name all that he did to make the American locomotive a thing of mechanical beauty and his ideas live in it to-day and cannot be eliminated.

GEO. H. BROWN.

Dubuque, Ia.

Handy Engine Sanding Device.

A very neat labor-saving device in use at a number of terminal points on the Union Pacific Railway is shown in the accompanying illustration. It consists of a crane made out of 4 in. gas pipe, with its upper end bent to an angle of 90° and its lower end resting on a concrete foundation and revolving on roller bearings. The bucket is made out of waste parts of tender sheets, with a taper at its lower part and a slide in the bottom to release the required amount of sand. The bucket is hoisted by hand power with chain and tackle, but compressed air from the locomotive can be used, if desired.

Immediately after an engine is sanded the bucket is lowered to the sand drier

for a new supply and this is attended to by the hostler's helper, while the hostler spots the engine on the table. By this arrangement it has been found that the helper can attend to the drier in addition to his regular work, and the necessity of installing an expensive and more or less unsatisfactory elevator operated by air has been abolished, and the services of the sand-house man dispensed with. J. A. B.

It Takes Coal to Pull Cars.

A recent article in RAILWAY AND LOCOMOTIVE ENGINEERING brings to mind some of the discussions that have enlivened the past in regard to the best way of firing engines, both as a matter of saving coal and of reducing the smoke nuisance. There is probably much left to be said on these subjects, and so far as I can remember the most important feature of the matter has been touched upon very lightly, if at all; that is, the co-operation, the working together, of the engineer and fireman. As many an engine goes over the road, it would look as if the engineer and fireman were trying to work against one another—the engineer trying to keep the steam pressure down while the fireman is trying just as hard to keep it up.

There is no denying that there is much reckless firing going on all over the country and there is lots of encouragement for it in the way some engineers handle their engines. "You put it into her and I'll take it out of her" has been the only sort of direction or advice many a fireman has received from engineers who were conceited enough to think they were "all right" in every respect.

Most of those who have sought to lay down an infallible rule for firing an engine have overlooked a most important factor in the use of coal. There can be no iron-clad rule for firing that will fit all the conditions of service in handling trains; or one that will supply judgment and common sense where they are most needed. Any engineer who will take an interest in his fireman's work, and a fireman who considers that it is his duty to save all the coal he can, will make a team for economical firing and working of an engine that will not need any printed directions as to whether one shovelful of coal or ten of them is enough for a fire. It takes coal to pull cars and of course the burning of that coal is bound to be attended with considerable waste if care is not exercised by both the engineer and fireman. There are many times that the engineer knows in advance of his fireman of a stop to be made, or where it will be part of his program to stop using steam. In such cases it is only fair to the company and the fireman as well to warn the fireman to cease firing, and in that way to save a little coal. This done

several times on a trip will have quite an amount of coal for the company and cost the men nothing. It will also help the fireman to learn more about economical use of all that is put onto or into an engine and do much toward making a better engineer of him. If a fireman is not educated to the economical with the coal put at his disposal when he is a fireman, he is missing much of the training that will enable him to use steam economically when he gets to handling the throttle in place of the shovel.

There are many different kinds of firemen and nearly as many ways of doing their work as there are firemen; but there is scarcely any fireman that cannot learn an easy way of doing his work if given a chance, and there is scarcely any fireman but can learn a right way instead of a wrong way if his engineer will only take an interest in the fireman's work, with the intention of making it as good as can be. There are some

had a hard time drilling him into a decent way of firing, and it was only by showing him how much less coal he would need to shovel that I got him at last to try and save coal.

Another fireman I had "stood in" with me to save coal and on a division of 166 miles long we succeeded in making three round trips in succession without letting the engine pop, and there was plenty of steam for all the work the engine had to do. Lots of times we would make a trip one way or the other over the road without letting the engine blow off any steam. It was a case of the two men working with each other for a common purpose.

I have heard firemen telling what hard trips they have had going over the road and burning so much coal, and I have seen those same firemen finish up a twelve-shovel fire just a second or two before steam was shut off at a station where they knew the train was to stop, and then the engine would pop, and

men follow who fire for me, and that is. "Always have a place for every shovel-ful of coal you put in, and then put it there."

Two, three or four shovel-ful of coal will often serve the company as well as six, eight or ten and very often saves the discomfort of popping and smoking engines in the vicinity of stations or other trains.

Every now and then some one tries to get up some coal saver that does not take brains to run it; but at the same time it takes quite a lot of attention from some one to make a success of it, and if there is any contrivance that can be put onto an engine that is better than brains properly applied I would like to hear of it. Every good fireman differs a little from other firemen in his ways of work, and although their differences are not worth describing it is often a matter of controversy on the part of an engineer and a new fireman as to how some trifling duty shall be performed.



ANGUS SHOPS, CANADIAN PACIFIC RAILWAY, MONTREAL, CANADA.

firemen, however, who can "bail" coal into an engine from one end of the road to the other and never get tired, who should be classed as "coal heavers" and not as firemen; all they think they need is a tank of coal and a hole to put it into, and if the engine doesn't stay hot with that sort of work they consider the engine is at fault and "needs fixin'."

A fireman that I had some years ago used to clean his ash pan before he started out on his run and then four times more on a run of 135 miles. His fire was always shaken down thin and there was always room in his pan for him to shake the fire when it was necessary. A fireman that followed him on the same engine considered it a wrong practice to clean out his ash pan till it was so full that he could not shake the grates any more, and he generally put off shaking the grates till the engine was failing in steam for the want of it. One fireman cost the company more than his wages over the other fireman, and I

then the other injector would go on and if the boiler was already pretty full it would have to be shut off again pretty quickly and then the engine would pop some more. If there was room for some more water both injectors would stay on till there wasn't room for any more, and then when the engineer pulled out, the fireman would throw in some more coal, and then the engine would pop again and begin to work water, and then the engineer would pop, and the next time they got a chance they would work this same program again. Then if they had to take coal on the road and the men that were coupled in them would pass the coal pile when there would be a chance for an argument as to whether both engines were doing their proper amount of work. Of course the two men who were wasting the fuel of the company knew their business as well as the other two—but they were not doing it as well.

There is one rule I try to have all

These little differences often prevent the two from working in harmony. The main thing to be kept in view by the engineer should be whether the fireman is working to the best of his ability for the benefit of the company rather than to think he is the only one the fireman is supposed to please. More harmony and interdependence is the thing that is needed, rather than independence and carelessness in ways of work; and we all ought to work with the idea that "there are others" besides ourselves, and by so doing make our work easier for ourselves and more subject to the approval of our employers. A. J. McKAY.

Sacramento, Cal.

The Saxon.

The Mason engine "Saxon," 136, was built and placed on the L. S. & M. S. Railway in the latter part of 1871, instead of 1856, as stated in May number of your most interesting publication.

Seeing request in June number for

information from any reader, I give you the date, as I frequently saw the engine when it was new and running on the Western Division. R.

Elmira, N. Y.

Valve Testing and Locking Device.

The valve testing and locking device, of which two line cuts are here shown, is the invention of Mr. J. A. Sadler, foreman for the Houston & Texas Central Railroad, at Dennison, Texas. The object of the invention is to provide a

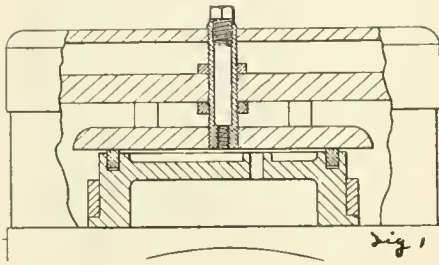

VALVE WITH TEST PLUG.

suitable means of detecting valve blows, either from a cut valve seat, broken strip springs or strips, without the necessity of removing the chest cover and finding that the wrong cover has been taken up.

It also provides for the locking of the valve in its central position where necessity compels one to disconnect any part of the valve gear.

Fig. 1 shows the valve with the chest plug in normal position. This plug is to be removed entirely when testing for blows.

Fig. 2 shows the valve with the plug screwed down on the crown of the valve in the holding position after any part of the gear has been disconnected. It will be noticed also that the sleeve in which the plug operates is screwed through the chest cover and table, making a

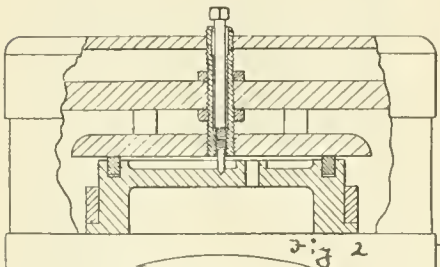

DISCONNECTED VALVE WITH LOCK BOLT.

tight joint, and as an extra precaution is secured by jam nuts to the top and bottom of chest cover.

J. A. BAKER.

The two associations heretofore known as The International Association of Car Accountants and Car Service Officers and The Railway Transportation Association have been consolidated under the title of the Association of Transportation and Car Accounting Officers.

The Product of the Galena Signal Oil Company.

Anybody who is rash enough to say "all oil looks alike to me" has only to pay a visit to the Galena Signal Oil Company's works at Franklin, Pa., to see the very great inaccuracy of that statement. The whole of the western portion of Pennsylvania is rich in deposits of bituminous coal and in the bituminous districts there are great deposits of petroleum. Petroleum is a rock oil, as its name implies, the word being derived from the Greek *petra*, a rock, and *oleum*, oil, and so great is the deposit of this substance in the western part of the state that the words of Job may be used without the least exaggeration—"And the rock poured me out rivers of oil."

In 1847 a chemist named James Young found an oil spring in Alferton, Eng-

heat and that the vapor has condensed and the liquid has been imprisoned in huge cavernous spaces in the bowels of the earth.

The oil wells of Pennsylvania are really artesian wells and penetrate the rock to a distance from 800 to 1,500 feet. The method of drilling one of these wells is first to erect the frame structure, called a derrick, over the spot where oil is believed to be. The structure is from 50 to 80 feet high and is broad based and tapers towards the top. From the crown pulley of this derrick steel pointed drills are operated, and as the cutting tool gradually worked its way down through the rock many lengths of pipe are added. The drilling consists of raising and lowering the cutting tool and turning it round in the hole just as hand drilling used to be done. When a well has been driven the required depth a charge of

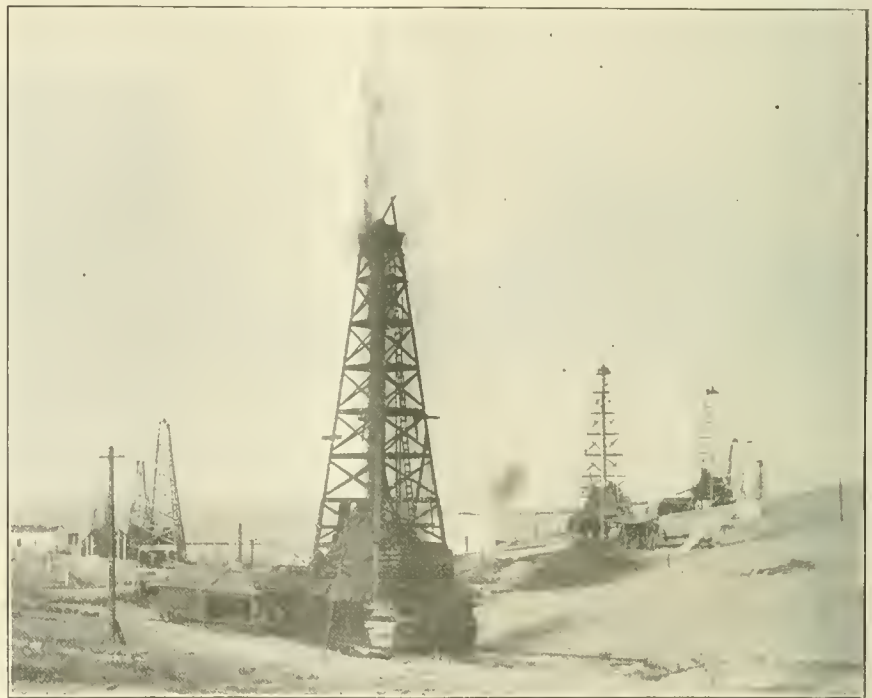

WELL SHOT WITH NITRO GLYCERINE AFTER BEING DRILLED.

land. From the product of this spring he distilled a light thin oil for burning in lamps, and at the same time he obtained a thicker oil for lubricating machinery. When the supply began to fail he noticed that the oil was dropping from the sandstone roof of a coal mine, he conjectured that petroleum was formed by the action of heat on a coal seam. He tried a great many experiments to prove the theory. At length, by distilling coal at a low red heat he succeeded in obtaining an oil resembling petroleum, which, when treated in the same way as the natural oil, yielded a burning oil, a lubricating oil and paraffine. It is believed that petroleum, wherever found, has in some way been distilled from coal beds of subterranean

nitro-glycerine is lowered to the very bottom, probably as much as fifty quarts being used for a single detonation. The discharge of nitro-glycerine at the bottom of the well breaks up the rock in all directions and produces a series of irregular fissures and crevasses through which the oil flows to the well. The oil is raised by what is nothing more or less than a lift pump, as there is no pressure tending to make the oil flow to the surface. The illustration which we give showing oil being forcibly blown out of the well is a snapshot of the D. Grimm No. 8 Highfield Farm well, shot with nitro-glycerine and photographed in the act of discharge. The explosion throws out a copious splash of oil at the moment, but this is by no means a con-

tinuous performance. The oil which is obtained in this region is known as Franklin crude oil. This is a natural lubricating oil and is worth very nearly four times as much as the oil which is obtained in other parts of the state. It does not make a good lighting oil, as it contains ingredients which are specially valuable in the matter of lubrication. In order to enhance the already excellent lubricating qualities of this oil, the Galena Company, after ridding the crude oil of any impurities such as earthy matter, which may be held in suspension, add two ingredients to the Franklin product. A mixture of the red oxide of lead and the ordinary whale oil of commerce is added to a quantity of the Franklin crude oil. The whole is thoroughly mixed in a large tank and while being heated to the requisite temperature the mass is mechanically agitated by revolving paddles. Lead is acknowledged

of the oxide of lead in the preparation of Galena oil that has caused the company to adopt it.

Perfection valve oil and perfection signal oil are also products of the Galena Signal Oil Company. Both of these oils are made from special stocks of high grade petroleum and animal oils mixed in certain proportions and heated to a predetermined temperature. The object which has been sought and obtained in the manufacture of perfection valve oil is the production of a lubricant which will not be adversely affected by the necessarily extreme temperatures of modern high pressure steam. The constituents of this valve oil do not contain the acids usually found in many lubricants intended for high temperatures and which have a powerfully corrosive effect upon the valve face and steam chambers. The fact that it is non-corrosive and that it

and on 92 per cent of these the Galena oils are used. The cars of the Dominion are stated to be 97,494, and 96 per cent. run cool with Galena oil.

The publication of which we speak contains a very serviceable map of the United States and Canada, and on it all the railroads using Galena oils are outlined in red; some useful information concerning the company's business not only on this continent but in foreign countries, is also given. The company will be very happy to send this map to any one who writes to them for a copy. Gen. Charles Miller is president of the Galena Signal Oil Company and Mr. F. H. Johnson is the secretary. The home offices of the company are situated in Franklin, Pa.

The Mirageoscope.

"Mirageoscope" is a striking word and is not the name loaded by scien-



TYPICAL OIL COUNTRY SCENE.

to be an ideal metal as far as anti-friction is concerned and the red oxide when mixed with whale oil and introduced in proper proportions and under specific temperature conditions produces not only a mechanical mixture of the ingredients, but forms a close chemical union. The vehicle by which this compound is carried is the natural lubricant drawn from the subterranean deposits in the neighborhood of Franklin, Pa. It is thus evident that the product of the Galena works is not only naturally but artificially endowed with qualities which render it superior to any ordinary lubricating oil.

In this connection it is interesting to state that the word Galena, which is used in the name of this well known company, comes from the name of an ore of lead and it is no doubt the use

retains its characteristic as a lubricant under all circumstances are great advantages in themselves, and they are heightened by the excellent qualities of the materials used.

In a publication recently got out by the Galena Signal Oil Company, we find that the railway mileage of the United States is given at 194,321.09 miles, and of this 93 per cent. use Galena oils. It is estimated that this country has 38,065 locomotives in service, of which 95 per cent. use the Galena oils. There are said to be 1,385,253, and 97 per cent. of these are lubricated with Galena oil.

The statistics for Canada are given separately. That country is said to have 17,648.77 miles of road, 85 per cent. of which use Galena oils. The number of engines is given at 2,465.

tists upon an extinct animal but is an invention intended to protect railroad trains. Sherman M. Hobson, of Pueblo, Col., who is a State agent for the Colorado Humane Society, is credited with having invented this contrivance. He claims to have worked out effectively the theory that the sky forms a mirror. His apparatus reproduces reflections in the sky and enables the operator to see the whole country within a radius of six miles from his position. A train of cars equipped with the mirageoscope, therefore, can be forewarned six miles ahead.

Although Mr. Hobson does not claim that his instrument is in a perfected condition, he says that he has, on several occasions, prevented train wrecks by its use. The mirage-scope enabled the Denver & Rio Grande Railroad

Company to capture a would-be train wrecker, and at another time it detected an incendiary in the act of setting fire to a bridge.

The editors of railroad papers are seldom nowadays overworked editing poetry, but in the early days of railroad journalism they appear to have been heavily loaded with emanations of the muse. In 1832 the editor of the *Railroad Journal* complained that he was overworked on poetic effusions and published about two thousand words of extracts and criticism. One epic poem called "Steamiad," of the heroic order,

the casting to a cherry red and dip it into a bath containing preferably sulphuric acid of a specific gravity of approximately 1.84 and red arsenic in the proportions of $\frac{3}{4}$ lb. of red arsenic crystals to one gallon of sulphuric acid. The best results are said to be obtained when the arsenic crystals are added to the sulphuric acid and both allowed to stand for about a week before using.

The change which the inventors claim takes place in castings hardened thus, is in the nature of a molecular rearrangement or recrystallization together with an increase of the combined carbon, and a lessening of the graphitic

Boston & Maine's Booklet on the St. Louis Exposition.

The St. Louis Exposition is daily drawing large crowds, and the attendance thus far has surpassed the opening month at Chicago.

The Exposition is startling in the completeness of such an enormous and magnificent spectacle. The amusement feature known as the "Pike" is really marvelous; however, the same may be applied to other portions, and to mention the points of interest would require much space.

If you contemplate visiting St. Louis, send to the Passenger Department, Boston & Maine Railroad, Boston, for their beautiful illustrated booklet telling about the Exposition. It will be mailed upon receipt of a postal card.

"South African Rock Drill Tests" is an interesting leaflet just published by Rand Drill Company, of New York. It is a fac-simile reproduction of a page taken from the Johannesburg (South Africa) *Star*, and contains an account of the now famous drill tests carried on by the Engineers' Association of the Witwatersrand. The circular is folded and addressed on the back and has been sent to all mines and mine owners. The verbatim report of the engineers finds for the drills of American make, and Mr. Docharty supplements his article by the remark that the "Slugger" approaches the ideal.

The Baldwin Locomotive Works is such a high concern that when its force of employees varies, the change usually aggregates thousands. In the boom period of 1900-1903 the total rose to 16,000. This is being gradually reduced to 6,000. Most of the great railroads of the country are now equipped with new locomotives enough to last them for several years, and the locomotive builders will not be able to employ for some time to come a larger force than they acquired five years ago.

Good Fishing and Large Catches.

The warm spell of weather has brought forth the anglers, and the trout and salmon are now rising to the fly in Moosehead, the Rangeleys and the smaller ponds and lakes in Maine and New Hampshire. It is better fishing than at this time last year, because of the late opening season. If you contemplate a trip, send two cents in stamps to the Boston & Maine Passenger Department, Boston, for their book, "Fishing and Hunting." It tells you where to go and what to find. A booklet giving the fish and game laws of Maine, New Hampshire, Massachusetts, Vermont and Canada will be sent free, accompanying.



TRANSMISSION MECHANISM USED IN PUMPING.

was particularly imposing. It was in books like Homer's Iliad. It began with an invocation to the muse heaven-hell-thunder-Hoboken.

Patent Process for Hardening Cast Iron.

There has recently been a patent granted for a certain process of hardening cast iron. After articles have been treated according to this process they are said to be hard all the way through. Castings to be hardened can be machined as required.

The first step in the process is to heat

carbon. This is something different from case hardening. In the patent process some of the graphitic carbon becomes combined carbon, but in case hardening the carbon contained in the ingredients near the iron are taken up by the iron.

The more rapidly the castings are cooled the harder they become. The bath must contain ingredients of a high heat conducting power and there must be practically no water in the acid, as water tends to form a steam cushion around the metal and thus prevent the desired chemical action taking place.

Of Personal Interest.

"Locomotive Engineering" Endorsed.

At the biennial convention of the Brotherhood of Locomotive Engineers held recently at Los Angeles, Cal., the following expression of good will was unanimously passed by the convention:

"Resolved, That this body appreciates the stand taken by its three editors of LOCOMOTIVE ENGINEERING who are active members of this Brotherhood, for championing our cause. We, therefore, unqualifiedly endorse and approve that publication."

The Grand Chief Engineer.

BY E. J. RAUCH.

A man who was born with only the intelligence and capacity to be a wood chopper, if he applies himself, can, and will, become one of the best choppers in the camp.

Another, born with the characteristics of a statesman, if he lacks energy and ambition, will seldom rise above



MR. WARREN S. STONE.

mediocrity in his way through life. There never was a duller old saw than the one that says "all men are born equal." These thoughts ran through my brain during my visit to the late convention of the Brotherhood of Locomotive Engineers; and induced me to gather some data concerning the history of the newly elected and re-elected Grand Chief Engineer of that organization.

Bro. Warren S. Stone was born some 45 years ago on a farm (and is the son of a farmer) near Ainsworth, Washington county, Iowa. His early life

was the usual routine of a farmer's son; he took his share of such work as he could do, drove the cows to pasture, rode the horses to water, helped feed the pigs and fowls, and brought from the wood pile the supply of fuel for the kitchen stove. At an early age young Stone was sent to the neighboring public school during the winter months, where he mastered the elements of an English education. From the public school he graduated to the Academy at Washington, Iowa; passed through the Academy with all the honors, and then took a course in the college at Western Iowa, which he conquered with credit.

Leaving college in early manhood he did not have the ideas of a profession that so many college graduates indulge in. I am thinking, by the way, that is what gives the world so many poor preachers, doctors, and lawyers, instead of good shoemakers, bricklayers or blacksmiths. Young Stone's boyhood experience on the farm, grinding the blades of the mowing machine, with the attending work of taking out and replacing the rack, occasionally making small repairs to the thresher, etc., gave his mind a leaning towards mechanics, and there was no field so prolific in opportunities as the railroad. He made his debut as a fireman on the Chicago, Rock Island & Pacific Railroad in the latter part of 1879; fired an engine for about 4 years, when he was promoted to be an engineer. As soon as eligible he joined his interests with the B. of L. E. His qualifications and character were soon recognized by his fellows and he was elected and served two terms as F. A. E. of Division No. 181. He was then elected and served three terms as C. E. of same division; served one term as a member of Local Board of Adjustment; then chairman of the General Board of Adjustment two terms; and was made salaried chairman of the General Board of Adjustment on C., R. I. & P. system on January 1, 1903.

On the decease of the late Grand Chief Engineer, P. M. Arthur, in August, 1903, and the declination of all the eligible Grand Officers to accept the vacant position the Grand Officers, by the authority vested in them, and on the previous and frequent commendations of Bro. Stone, by the late Assistant General Chief Engineer, Brother A. B. Youngson, for his loyalty to the Order, and his conservative character and ability to present a case of the Engineers to railroad officials, sent for and

elected him to fill the unexpired term of the deceased Grand Chief Engineer.

Bro. Stone resigned as chairman of the General Board of Adjustment of the C., R. I. & P. system to take charge of an organization numbering close on to 50,000 members scattered over the entire continent of North America; and that, too, in a somewhat demoralized condition.

That the work of the new Grand Chief Engineer did not meet the approval of all is no doubt true, but that approval of his course and confidence in him, was voiced by the large majority by which he was elected, goes without saying.

Mr. W. C. Hunter, late General Air Brake Inspector, of the Intercolonial Railway, has been appointed manager of the New Brunswick Coal & Railway Co., with headquarters at Norton, N. B.

Mr. W. E. Symons, mechanical superintendent of the Gulf, Colorado & Santa



MR. W. E. SYMONS.

Fe Railway, at Cleburne, Texas, has resigned that position to become superintendent of machinery of the Kansas City Southern Railway, vice Mr. Mord Roberts, resigned. Mr. Symons entered railroad service as machinist on the Chicago, Rock Island & Pacific, at Chicago. After serving in minor positions on several lines, he became general foreman on the A., T. & S. F. at Chanute, Kan., master mechanic on the same road at Arkansas City, Kan., and at Raton, N. M.; master mechanic on the Mexican Central at San Luis Potosi, Mex., and superintendent of motive power of the Plant System.

Mr. William P. Appleyard, who has been elected president of the Master Car Builders' Association at the convention held in Saratoga last June, has had a varied experience. Leaving Notre Dame University in 1874, he was engaged in en-



MR. W. P. APPELYARD.

gineering work on the Capitol building then being constructed for the State of Michigan. On completion of this work in 1878, he engaged in the practice of engineering and architecture until 1886, when he went to the Pullman Company as mechanical inspector, later becoming superintendent of repairs, and afterward agent of the town of Pullman. In 1903 he went to the Old Colony System of the N. Y., N. H. & H. Railroad as general foreman of car department. In 1895 he became master car builder of the New York, New Haven & Hartford, with headquarters at New Haven, where he remained until February 1, 1904; on this date he returned to the Pullman Company as superintendent of equipment, which position he now holds.

Mr. Dwight Carson has been appointed superintendent of dining car and parlor car service on the Wheeling & Lake Erie Railroad, with headquarters at Detroit, Michigan.

Mr. Charles B. Adams has been appointed superintendent of transportation of the Wheeling & Lake Erie, in charge of all through passenger car service and equipment, with headquarters at St. Louis, Mo.

Mr. George J. Bussing has been appointed assistant superintendent of motive power and rolling stock of the Evansville & Terre Haute Railroad with headquarters at Evansville, Ind.

Mr. T. A. Walker has been appointed machine shop foreman of the Evansville shops of the Evansville & Terre Haute Railroad.

Mr. D. S. Cook has been appointed roundhouse foreman on the Evansville & Terre Haute Railroad at Evansville, Ind.

Mr. B. E. D. Stafford, who has been the representative in the Central West and Southeast the last four years for the Ewald Iron Company, has resigned.

Mr. C. E. Slayson has been appointed master mechanic of the Algoma Central & Hudson Bay Railway, with headquarters at Sault Ste. Marie, Ontario. Mr. Slayson has also charge of the Algoma Iron Works.

Our well known contributor, Mr. Ira A. Moore, who has been for several years shop foreman of the C., R. I. & P. shops, at Cedar Rapids, Ia., has been appointed general foreman of the Clover Leaf shops at Frankfort, Ind.

Mr. John Kirby, treasurer of the Master Car Builders' Association, began his active railroad work as long ago as 1854. He has been identified with that association since its inception in 1867, and was one of those who helped to bring that body into existence. Mr. Kirby has been more or less intimately connected all



MR. JOHN KIRBY.

along with the good work which the M. C. B. Association has done in the matter of car interchange rules. In December, 1876, a meeting of superintendents of motive power and of railroad master car builders was held in the Palmer House, Chicago, to formulate a code of rules governing the exchange of freight cars. Mr. Kirby was secretary of that meeting and, though there were some interchange rules in existence at the time, the increase of traffic necessitated an enlargement of the rules. All the old rules were embodied in the code and many more were added. Mr. Kirby occasionally writes for the technical press and keeps in touch with the railroad world. He lives in Adrian, Mich.

Mr. P. J. Colligan has been appointed master mechanic of the Springfield division of the Illinois Central Railroad, with office at Clinton, Ill., vice Mr. W. J. Haynen, resigned.

Mr. J. F. Lehun has been appointed

general foreman of the Clinton shops of the Illinois Central, vice Mr. P. J. Colligan, promoted.

Mr. W. J. Haynen, formerly master mechanic on the Illinois Central, has been appointed master mechanic on the Missouri division of the Iron Mountain Railroad, with office at De Soto, Mo.

Mr. D. B. Lockwood has been appointed mechanical engineer of the Cleveland, Cincinnati, Chicago & St. Louis Railway, with headquarters at Indianapolis, Ind., vice Mr. R. L. Ettenger, resigned, to accept service with another company.

Our friend, Mr. Thomas Tait, who left the Canadian Pacific to become railway commissioner of the Victorian Railways, appears to be making his mark. In a return recently received which gives the comparative results of working for ten months ending April, 1903, and April, 1904, we note a reduction of \$135,510 in working expenses.

Mr. W. E. Fowler, master car builder of the Canadian Pacific Railway, has been elected second vice-president of the M. C. B. Association at the recent convention. He was car builder on the St. L., I. M. & S., at Baring Cross Shops, Ark., from March, 1880, to September, 1882, after which he worked as car builder on the Union Pacific at Denver, Colo., October, 1882, to November, 1883. He was promoted to be car foreman at the same place from November, 1883, to 1889. Later he became general car foreman on the Denver, Texas & Fort Worth, Denver, Colo., 1890 to 1891; then car foreman on the Union Pacific at Denver, Colo., 1891 to 1893. Later, master car builder, U. P., D. & G., and Colorado & Southern, from 1894 to 1900; subsequently, general car inspector



MR. W. E. FOWLER.

and master car repairer with Southern Pacific at Sacramento, California, 1900 to 1902. After which he was appointed master car builder at Montreal, Canada, on the Canadian Pacific, from April, 1902, which position he now holds.

Mr. Peter H. Peck, master mechanic of the Chicago & Western Indiana Railway and Belt Railway of Chicago, has been elected pres-



MR. PETER H. PECK.

ident of the American Railway Master Mechanics' Association. Mr. Peck was born at Decatur, Ill., and began his career in the shops and as a locomotive fireman on the Des Moines Valley Railway, after which he became locomotive engineer on the same road. In January, 1876, he transferred himself to the St. Louis, Keokuk & Northwestern, upon which road he worked as engineer. In August, 1878, he went as locomotive engineer to the Hannibal & St. Joseph Railroad. In November, 1882, he became division master mechanic on the same road at Brookfield, Mo., and later master mechanic on the Chicago & Western Indiana and Belt Ry.



MR. W. MCINTOSH.

Mr. William McIntosh, now third vice-president of the Master Mechanics' Association, was born in Huntington County, Quebec, Canada, in 1849. He went to

Wisconsin in 1863 and commenced rail-roading in 1864 on the Chicago, Milwaukee & St. Paul Railway firing locomotives. He remained with that company until 1870 as fireman, engineer and machinist. He then went to St. Paul and worked in the shops of the St. Paul & Pacific, now a part of the Great Northern, and remained there until 1872. In that year he went with the Chicago & Northwestern, Pacific division, as engineer, foreman and master mechanic. He was master mechanic on the Minnesota & Dakota division twelve years. In 1899 he came to the Central Railroad of New Jersey as superintendent of motive power.

Mr. H. F. Ball, superintendent of motive power of the Lake Shore & Michigan Central, at Cleveland, Ohio, has been elected first vice-president of the American Railway Master Mechanics' Association at the June convention. He entered railway service as an apprentice in the shop and in the drawing office on the Pennsyl-



MR. H. F. BALL.

vania at Altoona. He began service with L. S. & M. S. in 1890 as chief draughtsman car department, and served in that capacity for two years. Subsequently he held the positions of general foreman car shops at Cleveland, general car inspector and mechanical engineer until February, 1902, when he was appointed superintendent motive power of the Lake Shore, which position he now holds.

Mr. J. F. Deems, who is general superintendent of motive power of the Vanderbilt lines, was elected second vice-president of the American Railway Master Mechanics' Association at the recent convention at Saratoga. Mr. Deems is a native of Brownsville, Pa. He began his railroad work as an apprentice on the Baltimore & Ohio Railroad and later he worked for that company as a machinist. About sixteen years ago Mr. Deems went

to the Chicago, Burlington & Quincy and worked in the shop at Beardstown, Ill., as a machinist. He soon rose to be a gang foreman in the shop and was later



MR. J. F. DEEMS.

promoted to be roundhouse foreman. A little later on he was given the most important roundhouse on the road at Galesburg, Ill. He subsequently held the position of general foreman in the Beardstown shop and later became master mechanic at Ottumwa, Iowa. He was also master mechanic at Beardstown and at West Burlington. About three years ago he was appointed assistant superintendent of motive power and later became superintendent of motive power of the "Q." He was also connected with the American Locomotive Company as general superintendent of their Schenectady works. He left the service of the American Locomotive Company to join the Vanderbilt lines.



MR. ANGUS SINCLAIR.

Mr. Angus Sinclair, President and Editor-in-Chief of RAILWAY AND LOCOMOTIVE ENGINEERING, became a member of the American Railway Master Mechanics'

Association in 1883. In 1887 he was elected secretary of the association and held that position until 1895. In 1900 he was elected treasurer of the association, which position he holds at the present time.

Mr. F. J. Harrison has been promoted to the position of master mechanic of the Pittsburgh and Middle divisions of the Buffalo, Rochester & Pittsburgh Railway Company, with offices at DuBois, Pa., vice Mr. F. T. Hyndman, promoted.

Mr. M. J. Lynn has been appointed master mechanic of the Buffalo and Rochester divisions of the Buffalo, Rochester & Pittsburgh Railway, with offices at East Salamanca, vice J. A. Barhydt, resigned.

Mr. F. T. Hyndman has been promoted to the position of superintendent of motive power of the Buffalo, Rochester & Pittsburgh Railway, with office at Du Bois, Pa., vice Mr. C. E. Turner, resigned. Mr. Hyndman entered railway service as a machinist apprentice on the Central Railroad of New Jersey, at Ashley, Pa.; he subsequently went to the Lehigh Valley, as apprentice in shops, and later was brakeman and fireman on the C. R. R. of N. J.; machinist on the A., T. & S. F., at Raton, N. M. He worked as machinist on the Pittsburgh & Western, and in the Pittsburgh Locomotive Works. He also held the position of trainmaster and later on as master mechanic of the road at the head of whose motive power department he now is.

Mr. George Reith, formerly chief clerk to the general superintendent, has been appointed train master of the Northwest division of the Chicago Great Western Railway, vice Mr. H. M. Eshelman, resigned.

Mr. P. H. Cassidy has accepted the position as superintendent of the Staten Island Rapid Transit and Baltimore & Ohio, vice Mr. Burr, resigned.

Mr. Robert W. Baxter has been appointed superintendent of the Pennsylvania and New York division of the Lehigh Valley Railroad, vice Mr. J. A. Droege, resigned.

Mr. C. B. Adams has been appointed superintendent of transportation, in charge of through service of the Wabash-Pittsburgh Terminal Railway Company, with headquarters at St. Louis, Mo.

Mr. J. W. Patterson, Jr., has been appointed superintendent of the Wabash-Pittsburgh Terminal Railway, with headquarters at Pittsburgh, Pa.

Mr. B. D. Lockwood has been appointed mechanical engineer of the Cleveland, Cincinnati, Chicago & St. Louis Railroad, with headquarters at Indianapolis, Ind., vice Mr. R. L. Ettenger, resigned.

Mr. Joseph E. Buker, assistant superintendent of machinery at Chicago, on the Illinois Central Railroad, was elected first vice-president of the Master Car Build-

ers' Association, at the June convention, held in Saratoga, N. Y.

Mr. George N. Dow, master car builder of the Lake Shore & Michigan Central, at Collinwood, Ohio, was, at the June convention, elected third vice-president of the M. C. B. Association.

Mr. Fred Harris has severed his connection with the Rand Drill Company, of which he was formerly sales agent in Butte and Salt Lake City.

Mr. C. E. Burr, formerly superintendent of the Staten Island Rapid Transit and Baltimore & Ohio Railroads, has resigned to accept a position on the Chicago, Rock Island & Pacific, at Sapulpa, I. T.

New Patent Lathe Head.

There are several features of interest in connection with the lathe head here

tion. These features add greatly to the life of the spindle bearings, and at the same time keeps the spindle in perfect alignment all the time.

There are two sliding gears upon the back gear shaft, and either of these can be brought into gear by sliding them in one direction or in the other. Nine different speeds can be had in all. There is the direct pulley drive and the two gear speeds, and with three different counter-shaft speeds the range is considerable. The back gear ratios are 3 to 1 and 9 to 1.

The headstock is supplied with self oiling bearings. Deep oil wells have been cast in the bearings, each holding about a pint of oil. On the front of each bearing may be seen a curiously shaped lug which is bored and cut something like the mouth of an organ pipe. In this a glass tube is placed which indicates the level

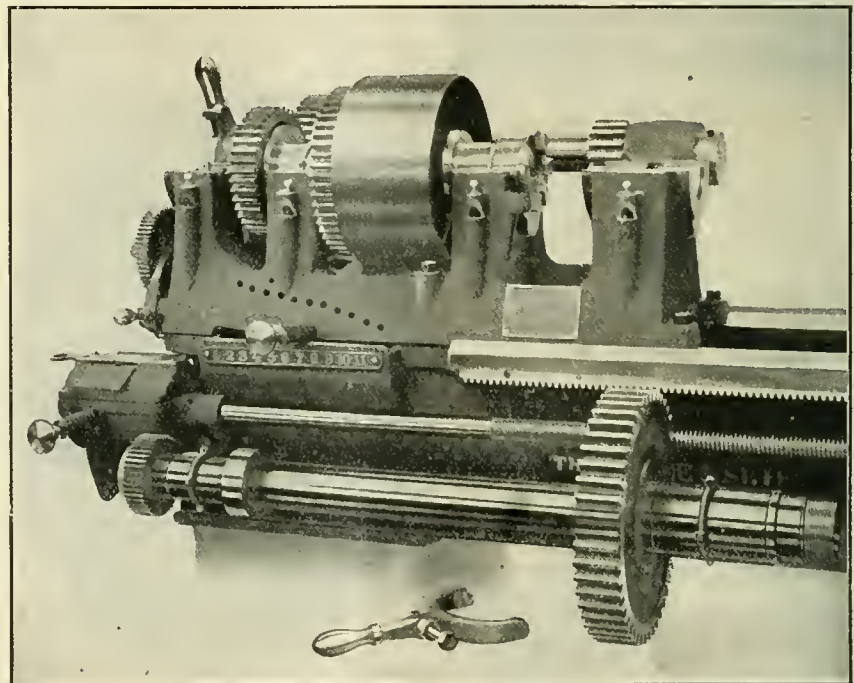

NEW LODGE & SHIPLEY PATENT LATHE HEAD.

illustrated. The improvement of the main spindle and its drive have been brought about by the heavy service which has followed the introduction of high speed steel.

The point probably most easily noticed is the absence of the familiar cone pulley and the substitution for it of a single pulley with very wide face. There are four bearings in this headstock, the two outer ones carry the main spindle, and the two inner ones carry the sleeve with the driving pulley. The main spindle passes through this sleeve with $\frac{1}{8}$ in. clearance between them, so that there is absolutely no belt strain on the spindle at any time. By this means it is possible to supply the necessary high speeds through the back gears, without running the pulley on the spindle, thus materially reducing fric-

of the oil in the well. The oiling is accomplished by brass rings placed one in the center of each of the spindle and sleeve bearings. These loose rings have projections which dip into the oil and in revolving continuously flow it over the bearing.

This lathe is not only a high speed lathe but it can be used on any class of work that can be done on the cone pulley head engine lathe. The good qualities of the engine lathe have been retained, but new and good features have been added, notably a very great increase in power. These lathes are made by the Lodge & Shipley Machine Tool Company, of Cincinnati, Ohio, who will be happy to give further particulars to those interested enough to write for them.

Automobiles Climb Mt. Washington.

BY ANGUS SINCLAIR.

To dare and to do is a trait of human nature that has accelerated immensely to the world's progress. For work and

from the base of the mountain, which has a total altitude of 6,293 feet.

On July 11, at an early hour, a large party of sightseers and automobile enthusiasts started from Mt. Pleasant

pushes it upwards about 3,700 ft., with an average ascent of 25 per cent., which, in one stretch, goes up at the rate of 1,980 ft. to the mile.

When we stop before the Summit Hotel, which is on the highest point of the mountain a magnificent spectacle is open to the view in this so-called Switzerland of America. More than twenty peaks and rugged mountain tops are within eye range, separated by gulleys and canyons that are varied by shining lakes, mountain torrents and calm crystal streams that wind their solitary way amidst a desolation of rock and wood covered vales, that separate the broken mountain ranges. The summit of Mt. Washington has originally been a huge cairn of gneiss and granite boulders, that have been split into fantastic fragments by the frosts of winter, the heat of summer and innumerable rain and snow storms extending over time that the imagination can scarcely grasp.

The purpose of our visit is to watch the fate of the sixteen automobiles which had been entered to climb from the base of the mountain to this region of rocks and of storms. The climb begins at Glen House, a hotel in the valley below, calls for an ascent of 4,600 ft. in eight miles, a height equal to the entire height above sea level of Ben Nevis, the highest mountain in the British Isles. Lifting an automobile up that eight miles rising 575 ft. to the mile, is a mechanical feat whose magnitude few people are able to realize. It calls for 218.5 pounds per ton



SUMMIT OF MT. WASHINGTON.

for sport the English speaking race are the leaders of the world and difficulties merely invite them to renewed enterprise of effort. The spur of this race characteristic made a great success of an automobile mountain climbing contest engineered by Mr. W. J. Morgan, one of the business staff of the *Automobile Magazine*. The feat undertaken was the climbing of Mt. Washington, the highest mountain in New England, on automobiles.

Mt. Washington is the summit of the White Mountain range, the northern part and highest peak of the Appalachian range of mountains which form the eastern backbone of the American continent and extend, with a few breaks, south from Maine to the Mississippi basin. The White Mountains form a delightful health resort for the people of New England and no region in the world is better provided with a pleasure ground where health and recreation can be sought amidst magnificent scenery, which is not used as an excuse to curtail creature comforts, for their supply leaves nothing to be desired beyond those provided in the magnificent hotels that liberal demands have brought into existence.

The facilities for enjoyment have been growing up for many years, the rack railroad that carries people to the top of the mountain having been built nearly forty years ago, having been the pioneer railroad of the cog species. Most of the hotel pleasure resorts are in the Bretton Woods, a few miles

Hotel, in the Bretton Woods, bound for the summit of the mountain. A single car, pulled by a ten wheel engine, takes the people up seven miles to the foot of the ascent which is made by the cog operated locomotive. The approach to



NEARING THE SUMMIT OF MT. WASHINGTON.

the base is by no means easy for the railroad rises 1,200 ft. in seven miles, the finishing two miles rising 316 ft. to the mile. Then the queer looking little locomotive hitches on to one car and

to overcome the resistance of gravity alone.

It is a high testimony to the power efficiency of automobiles to say that none of the machines entered to climb

the grade failed through deficiency of power, and one steam machine, the Stanley, entered as 6 horse power made the best record, having climbed the eight miles in a few second over 28 minutes, being $3\frac{1}{2}$ minutes per mile, equal to $17\frac{1}{8}$ miles an hour. The car weighs 800 pounds, so that 87.4 pounds of tractive power would be expended in overcoming the resistance of the grade alone, which is equivalent to about 4 horse power per hour.

It is not my purpose to give particulars of the racing, of the courageous dashes over rough roads, through blending clouds of fog, around many a breath-catching curve that gave too intimate visions of giddy precipices, suffice it to say that fifteen cars safely accomplished the hazardous journey and the world records a new triumph for daring, skill and nerve fortitude.

The scene to which the automobile race attracted visitors from afar fully rewarded the hardships that were incurred in a long hot journey. The prospect from the summit of Mt. Washington presents a world of life that is entirely absent from the tops of other high mountains I have visited where sterile desolation reigned supreme. The White Mountains are green to the highest peaks, even the cairn that crowns Mt. Washington being softened in tone by tufts of green wiry grass and even clinging wild flowers. We enjoyed a peculiar variety of weather, from bright warm sunshine to blinding mist. The summit is so high that clouds sometimes shrouded the scene below and storms were to be seen playing deluging pranks in the valleys beneath, while we remained untouched spectators. And what a kaleidoscope-like vision of racing colors was seen when the clouds threw their shadows over the hill sides and left rifts for the sun's rays to play through.

The railway that took us above the clouds has been the subject of many descriptions, but it will bear another brief write up. It was projected by Sylvester Marsh, who in 1858 petitioned the legislature of New Hampshire for a charter to build a railroad up Mt. Washington. Some of the legislators suggested that the charter might be made good for a railroad to the moon, which reflected the common sentiment about the enterprise. The promoter was persistent and work was begun in 1866 and the road was completed three years later.

The single rack rail through which power for climbing is applied is secured central between the wheel carrying rails and is in reality an iron ladder. The engine turns two sets of cog wheels which engage with the rungs of this ladder, thereby moving the train upwards. The structure appears to be very light, but long operation without accident proves it to be strong enough for the purpose.

Designing a locomotive for this work was originally a difficult engineering problem. The first engine tried had an upright boiler hung in trunnions. No pump or injector was provided. The boiler was filled with water at the bottom and was run until the supply was exhausted, when a stop was made and the boiler filled up by buckets. That engine is now in the Field Museum, Chicago.

The developed engine has four cylinders from which power is transmitted to shafts carrying the climbing cogs. Each cylinder has only one eccentric, so there is no reverse motion proper, but the engines can be moved backwards by admitting the steam through the exhaust cavity of the valves. In descending the mountain the cylinders of the engine are converted into air pumps that retard the movement of the pistons, a jet of water entering the steam chest to be used in dissipating the heat of piston compression. Excellent precautions are provided for controlling the movement of the train. Mr. John Thorne, an engineer belonging to the Boston & Maine Railroad, is in charge of Mt. Washington Railway.

There is a good hotel at the top of the mountain and a first class daily newspaper, *Among the Clouds*, is published there by Frank H. Burt, from whom I received many courtesies.

Revision of Standards.

The report of the Master Mechanics' committee on the Revision of the Association's Standards presents some interesting facts when it comes to the question of boiler and fire box steel.

To make a long story short, the committee recommends that the Master Mechanics' specifications for boiler and fire box steel be revised and that those of the American Society for Testing Materials be adopted, and the reason for advocating this change is briefly as follows: The M. M.'s specifications speak of "shell sheets," while the new specifications refer practically to the same quality by the name "flange or boiler steel." The M. M.'s specification requires a tensile strength of this grade of 55,000 to 65,000 lbs. and a minimum elongation of 20 per cent. in 8 ins. The new specification does not change the tensile strength, but requires a minimum elongation of 25 per cent. in 8 ins. For material over $\frac{3}{4}$ in. thick, deduct 1 per cent. for each $\frac{1}{8}$ in. excess.

The change for elongation from 20 to 25 per cent. insures a steel of sufficient ductility, especially in steel having as high a tensile strength as 65,000 lbs., whereas the M. M.'s specification, with its lower percentage of elongation, practically admitted steel of ordinary tank grade.

The M. M.'s specification did not in-

clude any chemical requirements, and it is now thought desirable to do so, and those of the American Society for Testing Materials appears to the committee to be what is required, as far as phosphorous, sulphur and manganese are concerned. The report states that carbon is not specified, and while it may not be necessary to include it in the requirements of shell sheets, it is thought desirable to retain the Master Mechanics' specification for fire box plates.

Other reasons for favoring the change are that some of the steel manufacturers will not work to M. M. Association specifications, while any mill will supply steel made to the standard of the American Society for Testing Materials, and most of them keep in stock a large supply of sheets made to the latter specifications. This enables orders for steel plates to be filled on short notice. Many railroads do not use the M. M.'s specification when ordering boiler steel, but adhere to that of the American Society for Testing Materials.

A Stop Kink from the Band.

At the railroad conventions held in Saratoga last June the well known Reeve's Band, of Providence, R. I., was in attendance as usual, with Mr. B. R. Church holding the baton of conductor. It is needless here to remark upon the excellent musical program rendered by this fine organization, or to say anything concerning the conductor's readiness to have the band play any selection asked for. All that goes without saying.

An interesting thing to watch, and not altogether without its usefulness to a railroad man, was to see the drummer of the band tighten up the snare drum heads so as to produce an even tension on the parchments. The two press hoops are grasped with clamps which are united by steel rods with a small thumb nut on top of each. These clamps are placed at intervals all round the drum, and the way the drum is tightened might be taken as a lesson on how to tighten up a smoke box door, a cylinder cover or a dome cap.

By the way, some people call the small, flat, cheese-shaped drum used in a military band, a kettle drum, but this it not correct. It is called a snare drum by reason of the fact that stretched across the lower drum head are four or six small, twisted rawhide cords which snap sharply on the lower head when the top head is struck and so add greatly to the resonance of the drum. It is from these cords or snares, as they are called, that the drum takes its name.

Now as to the tightening up in the band or in the shop. Suppose there were twelve clamps and we will call them by the names of the figures on the dial of a clock. The first operation would be to tighten up the XII o'clock clamp or

bolt or stud, as the case may be, then the III o'clock and then the VIII. Next would come the X, II and VI, then the IX, I and V, and lastly the XI, III and VII, and then a finishing touch all round, in order from I to XII. This gives an even tension and prevents undue strain being introduced at any point. In the shop it gives a good tight joint and with a drum it gives a sharper and better tone.

The Bettendorf Truck.

The official motto of the United States, "E Pluribus Unum," might almost be applied to the Bettendorf truck, for it is certainly the evolution of one out of many. The idea in designing this truck was to retain all the proved good qualities of the arch bar truck and at the same time effect a striking reduction in

and at the top the guides and columns engage with each other and keep the bolster in place.

The spring plank is a flat sheet steel member with a stamped rib at each end which engages with a suitable depression in the cast steel frame. The springs are easily slid in place by raising the bolster slightly and they are held where they belong by small bosses on the spring plank which enter the center of the coils.

When it is desired to put in a pair of wheels the truck is taken out from under a car and the truck is completely dismantled and new wheels applied. That sounds like a rather strenuous performance, but as it can be done in about half a minute and as it avoids several very troublesome contingencies which may arise at any time with an ordinary diamond arch bar

their line. The order consists of a full line of railroad tools, such as driving wheel lathes, axle lathes, ear wheel borers, steam hammers, large and small engine lathes, a very large quantity of punching and shearing machinery, also woodworking tools, radial drills, shapers, bolt cutters, brass lathes, grinding machinery, planers, steel tired wheel lathes, slotting machines, vertical and horizontal boring machines, centering machines, a full line of tool room tools and milling machines, also all the electrical traveling cranes required. This firm have also been given a large order from one of the Government power depots, consisting of engine lathes, shapers, radial drills, grinders, etc.; also, the various navy yards are being supplied by them with large forging machines, engine lathes, punches and shears, radial drills and grinders.

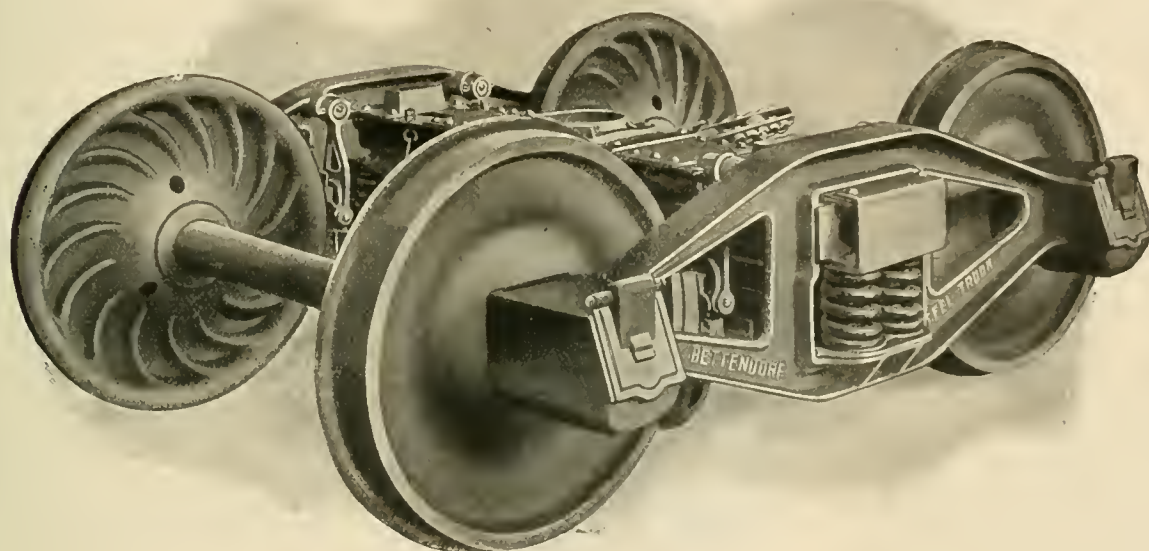

THE BETTENDORF TRUCK.

the number of separate parts, and also to reduce the weight of the whole.

The ordinary arch bar truck contained in one of its side frames forty-one parts, including bolts, nuts and split keys. The Bettendorf side frame, one may almost say, has fused all these parts together and produced one good, thoroughly annealed open hearth steel casting, which contains arch bars, columns, spring seat and journal boxes, and eliminates bolts, nuts and keys, and the total reduction of weight over the old style is about 1,000 lbs.

The Bettendorf truck fits together, that is the way to describe it, because there is not a bolt or rivet used in erecting it. The side frames are held in position by the column guides on the bolster. The bolster is pushed through the frame opening at the bottom where the columns are wide enough to let the column guides pass through, after which the bolster is lifted up to place

truck, it is not so very serious a thing after all. This truck has no rusty nuts to take off or bent bolts to drive out from the bottom.

The Bettendorf truck really makes use of the girder form of construction, whereas the ordinary arch bar truck is a truss. To dismantle a Bettendorf truck a long wooden lever and a chain are used or a chain and a bottlejack. An objection that is made is that the breakage of any part of the side frame on that side. This objection, however, is met by the makers, who agree to replace the frame on liberal terms. The Bettendorf Axle Company, of Davenport, Ia., make the truck.

Manning, Maxwell & Moore have secured from the Illinois Central Railroad a large order, amounting to between \$150,000 and \$160,000 worth of tools, to be shipped to the various shops along

The Central Railroad of New Jersey has also bought a large number of radial drills, engine lathes, grinders and woodworking tools. A number of railroad shop tools have recently been sold in the West.

The Acme Varnish Works, which is owned and operated by the Acme White Lead and Color Works, of Detroit, Mich., have put upon the market a light varnish which they call "Satinwood Finish." They say it is an interior finish of rare merit, and that it will rub nicely in from 36 to 48 hours. It is sold only in sealed cans. This is one of the company's "New Era" Ti-Ki Specialties. Write to the company for particulars if you want any information on the paint and varnish questions and they will be happy to answer you.

Mr. D. E. Fitzgerald has been appointed chief motive power clerk on the Frisco system with headquarters at St. Louis.

A Tender Lifter.

A very useful appliance is to be found in the tender shop of the Rogers Locomotive Works at Paterson, N. J. It consists of a yoke attachment used in connection with the overhead crane system, which in this case is complete in every way.

The yoke consists, as shown in the sketch, of a crossbar about ten feet long and 11 ins. deep in the center. From each end are suspended, from pin joints, two hangers about 9 feet high, having inwardly projecting arms. The hangers are spread apart about 7 feet at the bottom, and are rigidly braced.

The object which Mr. Ruben Wells,

been found to be very useful and many a short cut has been made with it when time pressed.

Care of Steel Tired Wheels on the Boston Elevated Railroad.

The mechanical department of the Boston Elevated Railway are, to use the expressive slang of the day, up against a very serious proposition in the matter of wheel maintenance. The main line is, in round numbers 10 miles long and makes a daily average of 20,000 car miles. There are twelve main line stations, which gives a total of twenty-three station stops in every round trip. There are no express trains as we know them

right, not merely enough to turn a car end for end, but sufficient to give it one complete revolution, just as if it had been put on a turntable and run round the entire circle to the right. The next mile would give it, say, a complete turn to the left, and so on during each mile it made. The curves on the road do not come in this regular sequence, but the effect produced is practically as if it was so.

This constant curving to the right and then to the left, repeated and re-repeated in the short total mileage of the trip produces very curious results. The wheels are pressed on the axles, just as they are on steam railroads, and when a curve is encountered, the wheel on one of the rails slips, while the other makes the legitimate number of revolutions. This small slip, first of one wheel and then of the other, produces a series of slight skids, not enough to condemn the wheels as far as steam railroad practice is concerned, but sufficient in time to cause a pound and to develop a very noticeable and objectionable noise on an elevated structure.

These minute skids, forming perhaps first near the flange and then on the outer edge, develop eventually into a series of lines across the tread of the steel tired wheels which the Boston Elevated road uses, and in time they cause a perfectly circular tire to become really a many sided polygon, as Euclid would probably say. Be that as it may, the city of Boston looks for as careful mechanical accuracy as it bestows on English grammar, and nothing but perfectly circular tires will do. The result of it all is that the Boston Elevated Railroad removes, grinds up true and replaces 48 steel tired wheels daily in order to reduce unnecessary noise and preserve the absolute circular integrity of their wheels.

An ordinary steam railroad would think itself very badly used if it had to do half this work for the mileage made, yet the Boston Elevated keep four wheel grinding machines constantly busy, each grinding 12 wheels per day of 10 hours, not to say anything about legitimate tire turning, which goes on as it would on any well organized railroad, when flanges become sharp or too deep.

Master Mechanics' Committees for 1904-5.

The Executive Committee of the American Railway Master Mechanics' Association met at Buffalo, July 25, and among other business arranged the committees of investigation for the coming year. The subjects and committees are:

1. Lading of Locomotives: Messrs. C. H. Hogan, H. T. Herr, D. F. Crawford and H. T. Bentley.
2. Pennsylvania Railroad Tests at St.

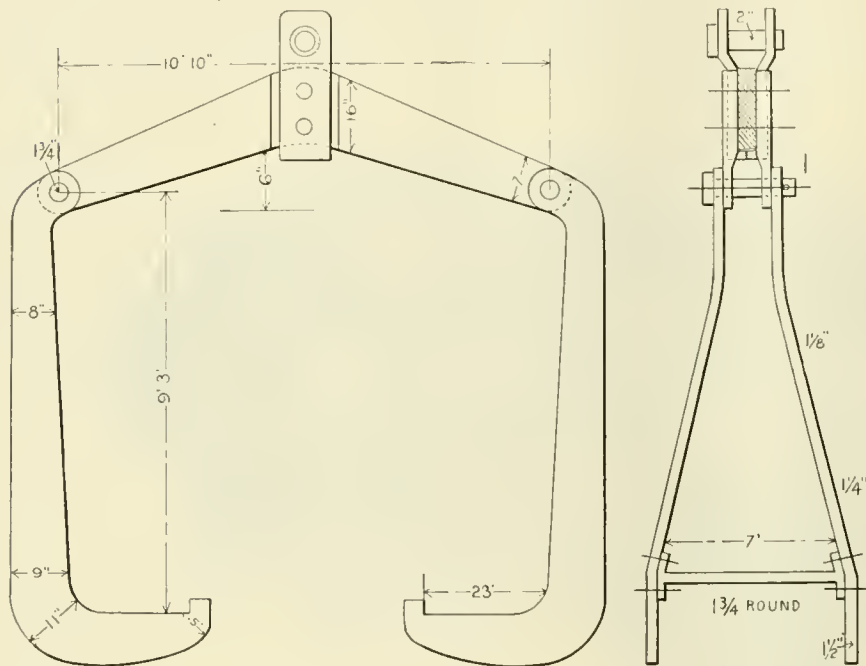

SLING YOKE FOR LIFTING TENDERS.

the superintendent of the works, had in view when he designed the yoke, was to facilitate the lifting of tenders, and carrying them about the shop as required. When it is desired to pick up a tender the overhead crane makes its appearance at the proper place with the yoke suspended from the grapling hook. As the yoke is lowered, two men, one on each side of the tender, seize the hangers and swing them clear of the tank and when at the right moment, the inwardly projecting arms of the hangers are allowed to drop in under the tender frames, and a lip at the inner end and the action of gravity prevents the possibility of their slipping out again. A tender can thus be swung up and carried out of the way or placed upon its trucks and run out of the shops in short order. When not in use the yoke hangs on a large iron bracket against the shop wall out of the way of the workers on the floor and yet below the runway of the electric traveling crane. The appliance has

in New York, but the maximum speed on certain portions of the road is as high as 45 miles per hour. The usual train is made up of four cars, each weighing thirty tons, making a total with passengers of about 136 tons to the train. Where the road enters and leaves the subway are two 5 per cent. grades, and about 11¼ tons of brake shoes are used up every month, the material being thrown down in the form of an almost impalpable dust, as the many trains slow up and halt at the stations, every few minutes during the day.

The road is not straight, as anyone who knows the historic city of Boston might reasonably surmise. As a matter of fact, in one trip of about 10 miles, the curves added together give a total turning equivalent of 9.43 or in other words each car in the train makes very nearly one complete turn for every mile run.

In order to understand what this means one may imagine a road starting out on a tangent and then curving to the



There Are Many Stops not on the Schedule

Among them altogether too many laid against the locomotive.

Statistics show that most of those are from overheated bearings.

Experience shows the cure to be

DIXON'S PURE FLAKE GRAPHITE

It waves the "clear road" signal to many an engineer who has struggled, with all his ingenuity, but in vain, to keep a hot bearing cool enough to run.

The action of Flake Graphite is to so polish and glaze the bearing with a hard, smooth veneer that abrasion cannot occur, and comparatively little oil will keep friction at its lowest possible point.

You can tell it in a minute by the ease of reversing and the power for pulling extra loads.

To anyone who has known the annoyance of a hot-box delay, we will send booklet 69-C and a sample—free.

JOSEPH DIXON CRUCIBLE CO.
Jersey City, N. J.

Louis Exposition: Messrs. F. H. Clark, H. H. Vaughan and F. M. Whyte.

3. Locomotive Front Ends: Messrs. H. H. Vaughan, F. H. Clark, Robert Quayle, A. W. Gibbs and W. F. M. Goss.

4. Locomotive Driving and Truck Axles and Forgings: Messrs. F. H. Clark, S. M. Vauclain, J. E. Sague, L. R. Pomeroy, E. B. Thompson and F. W. Lane.

5. Revision of Standards: Messrs. F. J. Cole, J. E. Muhlfeld, A. S. Vogt and W. A. Nettleton.

6. Motive Power Terminals: D. McBain, G. W. Wildin, C. E. Chambers, Peter Maher and W. R. McKeen, Jr.

7. Flexible Stay Bolts: Messrs. R. M. Durboro, F. M. Whyte, C. E. Fuller and O. H. Reynolds.

8. Water Softening: Messrs. J. A. Carney, L. H. Turner, F. N. Risteen, M. Dunn and Robert Quayle.

9. Organization for Mechanical Department: Messrs. William Forsyth, D. Van Alstyne, Henry Bartlett and John S. Chambers.

when the engine is drifting. When the valve is off its seat the passage marked A is in communication with the atmosphere through the opening marked D. Two of these valves are required for each cylinder. The valves do not flutter or knock in service and are perfectly tight under pressure. They permit the entrance of a large amount of air to the cylinders when the engine is drifting, and provide an easy escape for water when any finds its way into the cylinders. These are good points.

Exaggerated Claims for Diaphragm.

Your July issue contains a reprint of an article on the Climax Diaphragm, which has appeared in several of the railroad magazines. We infer, not only from the laudatory tone of that article but also from the fact that it has appeared elsewhere, that it is not the work of any of your own editorial writers.

We are not jealous of self congratulations nor are we alarmed because a new diaphragm has come into the field. We recognize the privilege of a competitor to cry up his goods, but there is a certain statement in regard to the riveted diaphragms in the article in question which, while not only untrue, is so intentionally misleading that it deserves contradiction. We refer to the comparison of sales of the riveted and sewed diaphragms during a given period. As there were no Climax Diaphragms for sale during that period, the comparison can only refer to the sewed diaphragm made by another manufacturer and to the Ajax Riveted Diaphragm made by ourselves. The writer of that article, had he access to our books, would, we are sure, be glad to recast his figures on the sales of the riveted diaphragms for fear that his inaccuracy in this item would lead to a serious doubt as to the correctness of his other figures.

His other statement to the effect that the riveted form of canvass diaphragm is being substituted by the sewed diaphragm can be controverted by simply looking at the vestibuled equipment of the leading railroads.

Since the invention of the Ajax Riveted Diaphragm the sales have increased from month to month, in fact its growth has been so rapid that our energies have been taxed to so great an extent to keep up with our orders that we have not found time to criticize our competitor's diaphragms in the public prints to the extent perhaps invited by their method of construction.

RAILWAY APPLIANCES COMPANY,
Percival Manchester, Secretary.

One has no business to take credit for good intentions.—*Dombey and Son.*

The Star Brass Manufacturing Company, of Boston, Mass., have recently got out a patented cylinder relief and vacu-

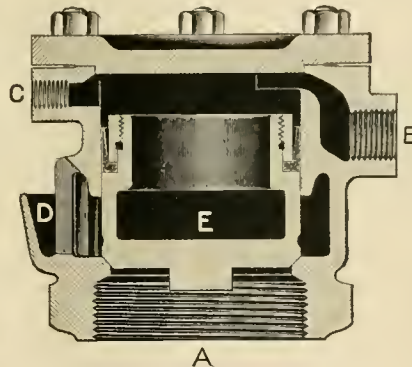

SECTION OF STAR AUTOMATIC CYLINDER RELIEF VALVE.

um valve which is designed to relieve any excess pressure due to water in the cylinder and it relieves to a great extent the vacuum caused in the cylinders when the engine is drifting. This valve is specially useful on compound engines having piston valves. The valve has no spring to break or corrode. As shown in the illustration the opening marked A is screwed to the steam cylinder, preferably to the port connecting the steam chest to the cylinder and it gives a full 3 in. opening. The opening marked B has a 3/4 in. pipe screwed into it, and this leads to the live steam chamber in the steam chest. To the opening at C is screwed a drain plug or cock. The valve E is held against its seat by the pressure from the valve chambers exerted on the greater area at the top, and the valve is lifted from its seat when a vacuum is formed in the live steam chamber

Concerning After Dinner Speeches.

A story is going the rounds of the press, very likely told on himself by Mr. Chauncey M. Depew. The story is to the effect that Mr. Depew got a letter from a gentleman who expressed great admiration for the senator from New York State, and said that he had derived the greatest pleasure from reading the newspaper accounts of that gifted orator's after dinner speeches and that he had often amused and entertained his friends with recitals of Mr. Depew's after dinner wit and humor, and that he had even gone to the length of publishing some of the speaker's most brilliant sallies.

The letter, however, went on to state that the writer had never heard a certain after dinner speech and that he longed and yearned to hear it, or to read it in print. He said it would afford him the keenest delight if he could hear the speech Mr. Depew would make after a dinner in the railway restaurant at Peekskill, N. Y.

An exceedingly handy little tool is described in a circular recently got out by the Chicago Pneumatic Tool Company. The tool is the Duntley Air Cooled Electric Drill, which is wound for 110 or 220 volts, as desired. The drill referred to in the circular weighs 12 lbs., and is adapted for drilling holes in iron up to $\frac{1}{2}$ in. and $\frac{3}{4}$ in. in wood. The speed is about 850 revolutions per minute, and a breast plate and feed screw go with each drill. One of its good points consists in the fact that it can be operated by connection with an ordinary incandescent lamp socket, so that almost anybody, anywhere can use one. The air cooled motor overcomes difficulties heretofore experienced with small motors. A ready means of strating and stopping the machine is an electric switch in the handle like the throttle handle on the Little Giant drills made by the same company. These drills will be made in sizes corresponding to the Little Giant drills. Write for circular if you are interested.

A very comprehensive catalogue, lately revised, has been got out by the Walworth Manufacturing Company, of Boston. The catalogue is bound in cloth with stiff cardboard covers; it is fully and clearly illustrated and contains, with index, over 350 pages. The pages are $7\frac{1}{2} \times 5$ ins. Among the numerous specialties made by this firm may be mentioned the Walworth injectors. Their "NT" locomotive lifting injector with screw starting valve is made in various sizes, which run from 600 gallons per hour to 3,400. Their improved "National" is made either with starting lever or screw starting valve. Locomotive non-lifting injectors are also catalogued. Among the list of tools are a fine line of Stilson

wrenches, from a small pocket tool which will grasp $\frac{1}{2}$ -in. pipe to large ones which will take 5-in. pipe. A very handy tool which can get into very tight, narrow places is what they call their Stilson automobile wrench. The jaws are about one-half as narrow as those of the ordinary small sized Stilson. Write the Boston firm if you want to make further enquiries.

Fittings Around the Tank.

BY JAMES KENNEDY.

There is, perhaps, no stranger feature in locomotive construction than the persistence with which utility is sacrificed to neatness in the fittings around the tank of a locomotive. One would naturally suppose that a large vessel of durable steel, unconnected with any working part of the engine, would be free from the frictional wear and tear incident to the movable portions of locomotive mechanism. That this is not the case is painfully evidenced by the unsightly patches to be seen on the tanks of certain classes of locomotives. The fitting of the tool box is perhaps the most usual, as it is the most pernicious cause of rapid decay of a portion of the tank. These boxes, when made of thin steel, as they generally are, and fitted with mechanical nicety to the tank—the sharp edge of the sheet touching the tank along the entire length of the tool box. The bolting of the box to the deck is done in such a way by the bolt holes being made at an inward angle that the tightening of the bolts induces a considerable pressure of the edge of the tool box towards the tank. It is supposed to be the perfection of workmanship when the painter has finished the exterior decorations that the tank and tool box look as if they were one piece.

Such fine workmanship is worse than useless. Not only is it labor thrown away, but it is a kind of labor that produces the most destructive results. Even if the tank were attached to a stationary engine and not subject to the incessant and irregular vibrations incident to all railroad machinery the continuous pressure of the thin edge of the steel sheet along the back of the tank could not fail to affect the adjoining metal and prematurely weaken the structure, but when we remember that a constant series of violent jars induce the sharpest kind of vibration, it can readily be imagined how rapidly a groove is cut into the tank, and in a few years a protecting patch and a re-fitting of the tool box become a necessity.

This is not all. Screw jacks, chains, hooks—all or anything especially of a rust covered kind are promiscuously thrown into the tool box. Old paint pots and tar tubs stiffen and coagulate



"Throw Away your Glue Pot"

Why have the smell of boiling Glue around you all day, and the waste and expense of boiling dry Glue, when you can for less money use

ARMY & NAVY LIQUID GLUE

Not a Fish Glue

but a pure hide and sinew glue in liquid form.

The Glue of the 20th Century

will do twenty-five per cent. more work than a fish glue.

No smell. No dirt. Always ready for use.

Let us send you Samples and Prices

WACHTER MFG. CO.
BALTIMORE, MARYLAND

Keep Your Mind On It



**CRANDALL'S HELIOS
AIR PUMP and
THROTTLE VALVE**

PACKING

**Put Up in Sets
Exact Fit to Rod and Box**

Send Trial Order

The Crandall Pkg. Co.

123 Liberty Street
N. Y. CITY

Chicago Office, 30 La Salle St.

in the filth laden corners and there is, perhaps, no place in or about a locomotive where the oxidation of metal is so rapid and destructive as in the tool box. The dirtiest water lingers there and the thickest rust gathers and in a short time the deck is eaten through and the tank is a mere skeleton.

All this is bad enough, but when we look at that class of engine where the cab overlaps the tank and observe the fittings of the sheets adjoining the tank we find the same pernicious methods generally in vogue. Sometimes a strip of small angle iron is fastened to the sheets bearing upon the tank with the view of broadening the bearing of the fittings, but the ingenious mechanic usually keeps the angle iron a little distance away from the edge of the sheet so as not to interfere with the fine fitting joint which always seems to be the real object of his efforts.

Along the top edge of the tank adjoining the cab, in the class of engines alluded to, the same methods are observable and if we add to this the regular poundings administered by the receiving of the supply of coal, sometimes from a considerable height, it is not to be wondered at that the upper face of the tank is in need of repairs in a very short time. This is especially the case with the rows of rivets along the lines where the coal strikes the tank in its thunderous descent. The heads of the rivets rapidly vanish, and the inevitable patch soon puts in its appearance.

Underneath the tank where one would think that no injury could ever come, the corroding influences are almost equally potent as in the tool box. Around the base of the tank there is usually riveted to the deck a strip of angle iron puttied and painted until it has become water tight. This forms a kind of dam dyke inside of which the water rests and the red rust eats its way to the heart of the hardest steel, and it is remarkable that a locomotive boiler, with all its violent subjections to the action of the fiercest fires without and the accumulation of corrosive substances within, shows less wear than the tank which, under fair conditions, ought to be the least liable to decay of any part of the locomotive.

As usual, however, it is easier to point out defects in construction and general treatment than it is to apply a remedy. In the matter of fitting tool boxes it would not be difficult to attach a rubber or hard wood sheathing between the tool box and the tank, and the same kind of preventive might be used on the other adjoining portions in the class of locomotives where the cab and tank overlap each other.

An extra sheathing could also be constructed to receive the coal, thereby saving the upper surface of the tank, such sheathing to be made readily changeable, thereby avoiding the patching of the tank in these parts.

Beneath the tank the space would better be left open. If the exposed surface of the tank was properly painted it would be much more durable than the present method of cohesion with other substances constantly soaked in water and subject to rapid corrosive influences.

Possibly some of the readers of RAILWAY AND LOCOMOTIVE ENGINEERING might suggest better methods of saving the tanks of locomotives from many of the evils to which they are now subjected. It is certainly a matter of pride and satisfaction to railroad men generally, that a magazine so ably and intelligently conducted opens its pages to every one who has anything to suggest in the way of improvement either in the construction, repairing or running of locomotives, and the adaptation of mechanical appliances used in railroad engineering.

Trophies.

Have you ever seen a boy returning from a school examination at the end of the term with prizes for proficiency and good work. These prizes are usually in the form of books, and the boy would probably call them trophies of victory, and so they are, for he has overcome obstacles in his studies.

The word "trophy" comes from a Greek word, meaning to turn, and a trophy originally was a collection of the arms and standards of the vanquished, which were set up in more or less imposing form upon the battle field at the point where the enemy had turned and fled. Nowadays a trophy is simply the evidence of success and that is what a prize is. When a boy does well at school and earns a prize he is usually given a book to help him on further.

We think a book is a very good thing to give as a prize or a trophy and a good book may really be a trophy in the old fashioned sense, because the information which you can get from a book written by an expert on the subject you want information on, may be a turning point for you. Look over the list of trophies which follow and see if some of them would help you on to victory.

The first on the list is, of course, RAILWAY AND LOCOMOTIVE ENGINEERING, a practical journal of railway motive power and rolling stock. It costs only \$2.00 a year, and is well worth the money, and besides the paper is a welcome visitor in every household. Let your wife and children see it.

"Twentieth Century Locomotives." Angus Sinclair Co., deals comprehensive-

UNION PACIFIC
OVERLAND
WORLD'S PICTORIAL LINE

**Over One
Thousand
Miles
A DAY
on**

"The Colorado Special"

Dinner in Chicago Today
Breakfast in Omaha Tomorrow Morning
Dinner in Denver Tomorrow Evening

**SPLENDID TRAIN SERVICE
to DENVER via UNION PACIFIC**

Full information cheerfully
furnished on application to
G. P. and Tkt. Agt.,
Omaha, Neb.

ly with the design, construction, repairing and operating of locomotives and railway machinery. First principles are explained. Steam and motive power is dealt with, workshop operations described, valve motion, care and management of locomotive boilers, operating locomotives, road repairs to engines, blows pounds in simple and compound engines, how to calculate power, train resistance, resistances on grades, etc. Shop tools explained. Shop receipts, definitions of technical terms, tables, etc. Descriptions and dimensions of the various types of standard locomotives. The book is well and clearly illustrated and is thoroughly up to date in all particulars, fully indexed. Just off the press. Price, \$3.00.

"Locomotive Engine Running and Management," by Angus Sinclair, is an old and universal favorite. A well-known general manager remarked in a meeting of railroad men lately, "I attribute much of my success in life to the inspiration of that book. It was my pocket companion for years." We sell it for \$2.00.

"Practical Shop Talks." Colvin. This is a very helpful book, combining instruction with amusement. It is a particularly useful book to the young mechanic. It has a stimulating effect in inducing him to study his business. The price of it is 50 cents.

"Examination Questions for Promotion." Thompson. This book is used by many master mechanics and traveling engineers in the examination of firemen for promotion and of engineers likely to be hired. It contains in small compass a large amount of information about the locomotive. Convenient pocket size. We cordially recommend this book. The price is 75 cents.

The 1904 Air Brake Catechism. Conger. Convenient size, 202 pages, well illustrated. Up to date information concerning the whole air brake problem, in question and answer form. Instructions on the operation of the Westinghouse and the New York Air Brakes, and has a list of examination questions for enginemen and trainmen. Bound only in cloth. Price, \$1.00.

"Compound Locomotives." Colvin. This book instructs a man so that he will understand the construction and operation of a compound locomotive as well as he now understands a simple engine. Tells all about running, break-downs and repairs. Convenient pocket size, bound in leather, \$1.00.

"Catechism of the Steam Plant." Hemenway. Contains information that will enable a man to take out a license to run a stationery engine. Tells about boilers, heating surface, horse power, condensers, feed water heaters, air pumps, engines, strength of boilers, testing boiler performances, etc., etc. This is only a partial list of its contents.

It is in the question and answer style. 128 pages. Pocket size. 50 cents.

"Care and Management of Locomotive Boilers." Raps. This is a book that ought to be in the hands of every person who is in any interested in keeping boilers in safe working order. Written by a foreman boilermaker. Also contains several chapters on oil burning locomotives. Price, 50 cents.

"Locomotive Link Motion." Halsey. Any person who gives a little study to this book ceases to find link motion a puzzle. Explains about valves and valve motion in plain language, easily understood. Price, \$1.00.

"Machine Shop Arithmetic." Colvin and Cheney. This is a book that no person engaged in mechanical occupations can afford to do without. Enables any workman to figure out all the shop and machine problems which are so puzzling for want of a little knowledge. We sell it for 50 cents.

"Firing Locomotives." Sinclair. Treats in an easy way the principles of combustion. While treating on the chemistry of heat and combustion, it is easily understood by every intelligent fireman. The price is 50 cents.

"Skeevers' Object Lessons." Hill. A collection of the famous object lesson stories which appeared in this paper several years ago. They are interesting, laughable and best of all they are of practical value to-day. \$1.00.

"Stories of the Railroad." Hill. Best railroad stories ever written. Those who have not read these stories have missed a great literary treat. \$1.50.

"Standard Train Rules." This is the code of Train Rules prepared by the American Railway Association, for the operating of all trains on single or double track. Used by nearly all railroads. Study of this book would prevent many collisions. Price, 50 cents.

"Mechanical Engineers' Pocket Book." Kent. This book contains 1,100 pages 6x3¼ inches of closely printed minion type, containing mechanical engineering matter. It ought to be in the bookcase of every engineer who takes an interest in engineering questions. We use it constantly as a reference for questions sent to us to be answered. Full of tables and illustrations. Morocco leather, \$5.00.

"Locomotives, Simple, Compound and Electric." Reagan. An excellent book for people interested in any kind of locomotive. It will be found particularly useful to men handling or repairing compound locomotives. It is the real locomotive up to date. \$2.50.

RAILWAY AND LOCOMOTIVE ENGINEERING. Bound volumes. \$3.00.

The F. B. Sturtevant Company announce the removal of their entire plant from Jamaica Plain to their new works at Hyde Park, Mass. They have nine acres of

H. S. PETERS'
BROTHERHOOD ^{TRADE MARK} OVERALLS

have gone to almost every part of the World where Overalls are worn and are everywhere conceded to be the **BEST**. Every point of material, cut, construction and finish is carefully looked after; the only way that superiority can be attained. Every garment is absolutely guaranteed. The Patented, Fleece-lined, Safety Watch Pocket is alone worth a whole suit of any other make.

I'll send sample suits, charges paid, to any place in the World where mail, or express, goes, where I have no retail agency; sample materials and full particulars for the asking.

UNION MADE
OF COURSE -
B.L.E. 3 - H.S. PETERS - B.L.E. 171
DOVER, NEW JERSEY, U. S. A.

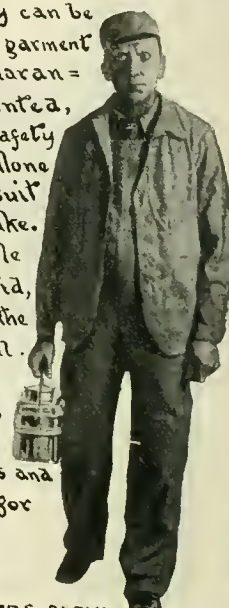

The Twentieth Century Master Mechanic

Won't use solid Mandrels. Cost too much, take up too much room and don't give satisfaction.

Nicholson Expanding Mandrels

Take everything from 1 to 7 inch holes. Take up little room—always ready and you can buy four sets for the cost of one of the solid kind.

Are You Using Them?

Catalogue tells you more about them.

W. H. Nicholson & Co.
Wilkesbarre, Pa.

Besides **ASHTON LOCOMOTIVE STEAM GAGES**



WE MAKE
Duplex Air Gages
Gage Testers
Blow-off Valves
Chime Steam Whistles
Pop Valves

ALL OF A SUPERIOR QUALITY
Catalogue L on Application

The Ashton Valve Company, 271 Franklin Street, Boston, Mass.

American Locomotive Sander Company

13th & Willow Sts., Philadelphia, Pa.

Proprietors and Manufacturers,

LEACH, SHERRBURNE, DEAN, HOUSTON, "SHE" and CURTIS **SANDERS**

JUST PUBLISHED

—THE—
LOCOMOTIVE UP TO DATE

The greatest accumulation of new and practical matter ever published treating upon the construction and management of modern locomotives, both

SIMPLE and COMPOUND

By **CHAS. McSHANE**

Author of "One Thousand Pointers for Machinists and Engineers,"

Special Exhaustive Articles were prepared for this new book by the

Baldwin Locomotive Works
Rogers Locomotive Company

Schenectady Locomotive Works

Pittsburg Loco. and Car Works

Brooks Locomotive Works

Dickson Locomotive Works

Cooke Loco. and Machine Co.

Richmond Loco. and Machine Co.

With contributions from more than one hundred prominent railway officials and inventors of special railway appliances.

736 Pages, 6x9 inches 380 Illustrations

An Absolute Authority on All Subjects relating to the Locomotive

Bound in Fine Cloth, \$2.50

ONE THOUSAND POINTERS

—FOR—
MACHINISTS and ENGINEERS

By **CHAS. McSHANE**
(Practical Machinist)

Assisted by CLINTON B. CONGER, Air Brake Expert; J. P. HINE, Mem. Div. 37, B. of L. E.; J. G. A. MEYER, Mechanical Engineer; W. M. F. Goss, Mechanical Engineer; Jno. C. WHITE, Indicator Expert. The only complete work on the locomotive combining both theory and practice. 342 pages, 187 illustrations.

BOUND IN FINE CLOTH, \$1.50

The only book ever indorsed by the International Association of Machinists Agents wanted everywhere; write for terms, commissions and club rates. Will be sent prepaid to any address upon receipt of price.

GRIFFIN & WINTERS, Pub.

171 La Salle St., CHICAGO, ILL., U. S. A

Vest Pocket Combination Tool



Wire Cutter, Screw Driver, Glass Cutter, Packing Hook and Burner Grip. Weight 4½ oz. Drop Forged Steel. Always useful Ever Ready.

In Leather Case. Price, \$1.50

WILLIAMS, FROST & CO.
WINONA, MINN.

floor space and all the modern appliances, and will continue to manufacture the well-known Sturtevant products: blowers, engines, motors, economizers, forges, steam heating, ventilating and drying apparatus, etc.

The Railway Appliances Company, of Chicago, announce that they have been appointed exclusive agents for the United States for the railway trade of the Old

conductive to long life. The speeds are five in number and advance in geometrical progression from 50 to 170 revolutions per minute. The frame may be said to consist of but five parts, the base, column, cap, arm and arm shaft, each of which are designed to stand up to the continuous and severe work which is expected of a machine of this character.

Some of the general dimensions are as follows: Diameter of spindle, least

section 1¼ ins.; spindle bored to fit Morse taper, No. 4; traverse of spindle, 18 ins.; horizontal range of head, 3 ft. 6¾ ins.; receives under spindle over table, 24 ins.; receives under spindle over base, 4 ft.; receives under spindle over floor, 4 ft. 7 ins.; drills work in plane of base to center of, 8 ft.; size of table, working surface, 20x20 ins.; size of base, working surface, 3x4 ft. 1 in.; distance from floor to extreme height of spindle, 9 ft. 4¼ ins.; number of revolutions of driving pulley to one revolution of spindle, 6.9; maximum diameter of driving cone, 18 ins.; size of tight and

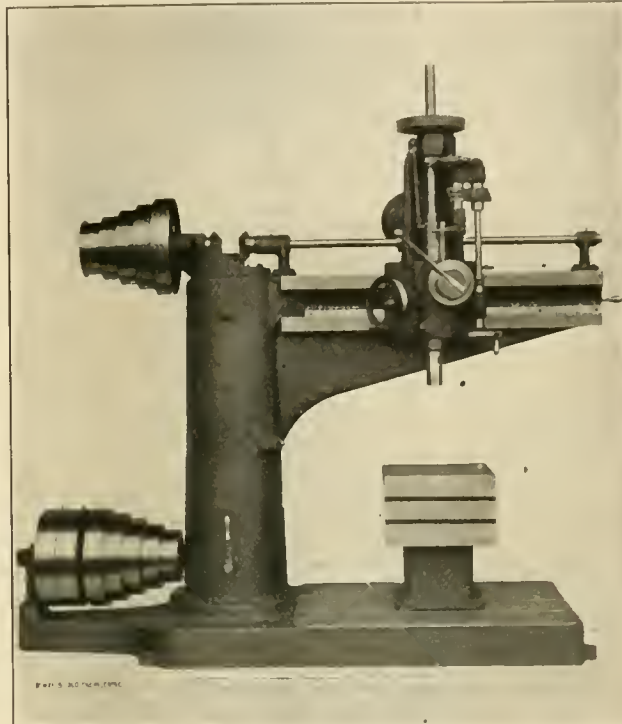

BICKFORD SEMI-RADIAL DRILL.

Motor Works, of Detroit and Lansing, Mich.

Semi-Radial Drill.

The chief characteristics of this machine are rigidity, simplicity and durability which, combined with a high ratio of transmission gears, make it an admirable tool for many classes of work. The head, on which all bearings are of uncommon length, consists of a single casting and is adjustable on the arm by means of a spiral gear which gives it an easy quick motion. The spindle is made of hammered steel and has an unusually extensive vertical adjustment for a machine of its size. It is provided with both hand and power feed and quick advance and return.

The feeding mechanism furnishes three rates of feed, advancing by even increments from .008 to .016 ins. per revolution of spindle, each of which is instantly available by means of the standard drive key. The driving mechanism contains but seven gears, the pitch and-periphery speed of which are

loose pulleys, 3¼x18 ins.; width of cone belt, 3 ins.; speed of countershaft, 350 rev.; floor space required, 9 ft. 3 ins. by 11 ft. 9 ins.; weight, net, 6,500 lbs.

This drill is manufactured by the Bickford Drill and Tool Company, of

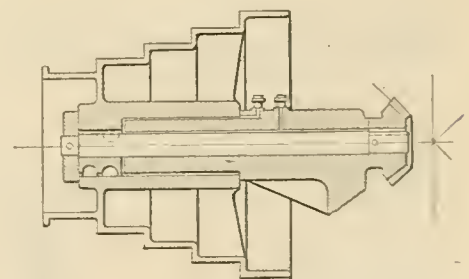

By J. Loom. Eng.

CONE PULLEY FOR SEMI-RADIAL DRILL.

Cincinnati, Ohio. The line cut shows the construction of the bearing for the upper cone pulley.

The blessed work of helping the world forward, happily does not wait to be done by perfect men.—George Eliot.

168 p. **BOOK** on
**AIR AND GAS
COMPRESSORS**

FREE

to anyone who
will **TELL US**
WHERE com-
pressed-air ap-
paratus is to be
installed. It
contains valu-
able **Formulae,**
Tables and
Information.
Write now. : :

**LIDLAW-DUNN-
GORDON CO.**

**116 Liberty Street
NEW YORK**

Flexible Spout

Vertically in straight
line. Also laterally.
The latest Improve-
ment to

Poage Water Columns

American Valve and Meter Company
CINCINNATI, OHIO.

SEND FOR CATALOGUE

THE DROP SEAT IN POSITION

Shipped Locomotive
Builders several large
consignments last
year. Ask for our seats
when your company is
ordering new engines.
The Mexican Central
Ry. Co. is putting our
drop seat No. 7 on all
their new engines.
We make 20 different
styles of Locomotive
Cab Seats, \$2 up. Send
for new Catalog D containing 100 illustrations
and full particulars, free. Send 10c. for Com-
plete Campers' Manual; or, How to Camp Out
and What to Do, a practical book of 130 pages,
worth \$1.

Stannard & White Co., Racine Jct., Wis.



"Imperial" Drills.

"Imperial" drills exhibit an advance
over conventional designs. The cylin-
ders revolve on a fixed crank pin in
which there are two ports, one for ad-
mission and one for exhaust. Thus, the



FIG. 1.
"IMPERIAL" MOTOR RUNNING AT 3,000
R. P. M. NO VIBRATION.

crank itself, which is a steel forging
case-hardened and ground, serves as a
valve and there are no eccentrics. The
motor consists of three cylinders which
are cast of steel in a single piece.
The cylinders are 120° apart and
radiate from a central hub. The
cylinders, however, are not truly ra-
dial, but are set off ¼ in. to ½
in., according to the size of the drill.
As a result of this set off the connecting
rods are practically perpendicular to the
piston head throughout the outward or
working stroke, thus minimizing the
wear of the cylinders and pistons.

The cylinders are hung between tri-
angular-shaped frames which revolve

ary disks upon which they revolve on
ball bearings. The stationary crank pin,
referred to above, is forged in a single
piece with the upper disk, the center of
the crank pin being set off from the cen-
ter of the disk by a distance equal to
one-half of the piston stroke. The cylin-
der hub through which the crank pin
passes is bored with a taper hole and has
a bronze bushing with corresponding
taper, thus permitting of adjustment to
take up wear. This tapered bushing has
three parts, registering with ports at the
end of each cylinder, and air is admitted
to and exhausted from the cylinders suc-
cessively through the ports in the crank
pin as the cylinders revolve, the crank
pin thus forming a Corliss valve.

All parts are perfectly balanced and all
rotation takes place about fixed centers,
resulting in absolute freedom from vi-
bration and consequent long life for the
tool. It will therefore be seen that, as
admission and exhaust takes place only
at this central crank pin, there is no
necessity for having the casing air tight.
This point is evidenced by Fig. 1, which
shows the "Imperial" motor without
casing working at 3,000 revolutions per
minute. This is an advantage over de-
signs where the casing must be kept air
tight by packing.

The power from the motor is
transferred to the spindle by a pin-
ion on the lower triangular frame,
gearing into a pair of traveling gears
which are attached to the head carrying
the drill spindle. An internal rack gear
is cut in the case into which the travel-
ing gears mesh, forming the combina-
tion known as "planet" gearing. The
thrust of the drill spindle is taken up by
ball bearings of large diameter. The
case, in which the motor and gears are
contained, is made oil tight. If desired
the motor can be run in a bath of oil.
All pins and bolts subjected to wear and
ball races are of steel, case hardened and
ground, and all working parts are of
phosphor bronze. The Imperial drills
are manufactured by the Rand Drill
Company of New York.

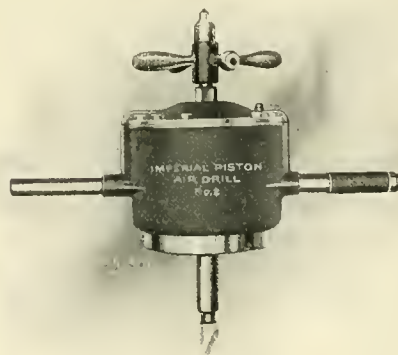
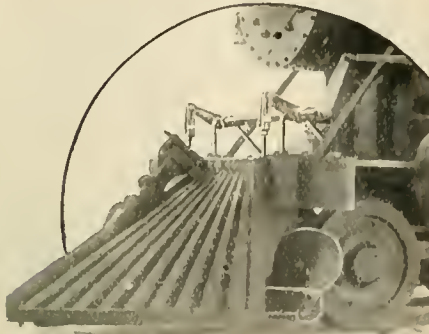

FIG. 2.
"IMPERIAL" PISTON DRILL.

with them, the connecting rods of the
pistons working on the pins which rigid-
ly connect the upper and lower frames.
These frames are mounted on station-

A neat little illustrated catalogue from
the John Davis Company of Chicago has
just come to hand. This concern manu-
factures such specialties as reducing
valves, steam traps, safety water columns,
separators, blow-off valves, pump regu-
lators, globe angle valves, check valves
and steam fittings. Enclosed with the
catalogue were a couple of facsimile let-
ters from a prominent superintendent of
motive power, who speaks in high terms
of praise of a No. 3 Eclipse reducing
valve purchased from the John Davis
Company. The other letter refers to a No.
7 Hochfeldt combination relief and back
pressure valve. The feature of the valve
which is favorably commented upon is
that it can be changed from a single seat

Q and C Priest Snow Flanger



Order now. Don't wait till winter. Send for catalogue.

RAILWAY APPLIANCES CO.

OLD COLONY BUILDING, CHICAGO
114 LIBERTY STREET, NEW YORK

THE ROBERT W. HUNT & CO.

Bureau of Inspection, Tests and Consultation,
1137 THE ROOKERY, CHICAGO.

66 Broadway, New York. Park Building, Pittsburgh.
31 Norfolk House, London, Eng.

Inspection of Steel Rails, Splice Bars, Railroad Cars, Wheels, Axles, etc. CHEMICAL LABORATORY—Analysis of Ores, Iron, Steel, Oils, Water, etc. PHYSICAL LABORATORY—Test of Metals, Drop and Pulling Test of Couplers, Draw Bars, etc.

Efficiency Tests of Hollers, Engines and Locomotives.

211 { Concise Answers
TO
Straight Questions

ON

Handling Locomotives

Instruction in
Catechism form
For Firemen
and Engineers'
Examinations

By

W. O. THOMPSON

Price 50 Cents

ANGUS SINCLAIR CO.

174 Broadway

valve to a double seat valve very quickly, which is an advantage where a shop is run with stationary engine condensing at one season and non-condensing at another. The John Davis Company will be happy to send the catalogue to any one who applies to them for it.

New No. 109 Automatic Band Rip Saw.

If any of our readers have ripping to do, the machine here represented will without doubt prove of considerable interest. The makers claim it will surpass in quality and amount of work done by any other of this class they may now be using. It is original in every respect and has just been built, and is strong in all parts. The makers were the first to introduce a machine of this kind and since being placed on the market it has proved to be a revelation to all those who have used it. It was patented

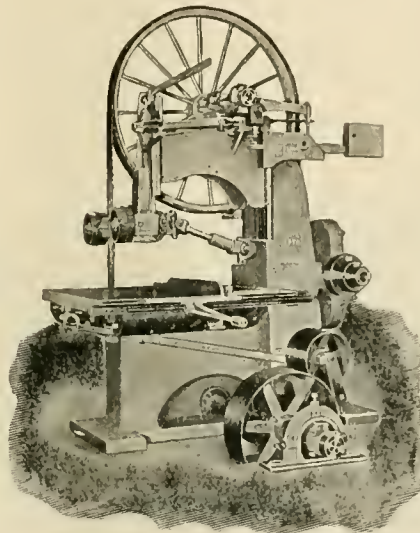

NEW BAND RIP SAW.

February 27, 1900, and October 2, 1900.

It presents such an array of improved features that limited space allows only a few to be mentioned, so that circulars should be sent for in order that its full value may be appreciated. It is designed especially for heavy work, and is particularly recommended to the car builder, the mill owner, makers of farm machinery, and to other wood workers who have stock that requires heavy framing. The machine is safe to operate, a very small kerf is removed, wide or thick material is easily ripped, little power is required, the work is always easily accomplished, the table is always at standard height, rolls are close together, allowing short pieces to be easily fed; adjustment of fences and rolls quickly made, and there is a great saving in time each day in making the various adjustments. It is admirably adapted to reducing large timbers to smaller dimensions, ripping wide lumber into strips of varying widths, resawing from the side of a timber, and other light work.

The straining device, which controls the upper wheel and the path of the saw blade on the face of the wheels is new and very sensitive and is covered by letters patent. No matter what the vibrations may be the strain takes up the slack in the blade instantly, thus adding wonderfully to the perfect working of the machine and lengthening the life of the saw blades.

The lower wheel is solid, lessening the circulation of dust and giving itself increased momentum so that its speed governs the upper wheel and prevents it from overrunning the lower. The machine has three feeds and powerfully driven feed rolls in and above the table, and by a single movement of a lever the machine can be instantly changed to a hand feed rip saw or the feed instantly stopped.

Further particulars can be obtained from the makers, J. A. Fay & Egan Co., of No. 445 West Front street, Cincinnati, O., who will also send their new catalogue of wood working machinery free to those desiring it, who will write mentioning this paper.

The Type of Economizer for Highest Efficiency.

The two most essential qualities of a fuel economizer are its ability to utilize for heating water the maximum amount of heat drawn from the escaping gases, and the accessibility of all its surfaces for cleaning, repairing and renewals. The Sturtevant "Standard" and "Pony" type of economizers were designed to make possible these two requisites. These economizers utilize practically all the waste heat by a patent system of staggered pipes. This system compels all the hot gases to encircle the pipes.

The joints of the Sturtevant Economizers are made taper metal to metal, and are so designed that any pipe can be taken out and a duplicate substituted without disturbing any other pipe, section or side walls. Any header can be withdrawn and a duplicate substituted without disturbing any other header, section or side walls. Any section can be withdrawn and a duplicate replaced without disturbing any other section or side walls. There are no connection pipes to remove and all water surfaces are rendered accessible by the simple removal of the caps.

The scrapers are interchangeable and the driving mechanism positive in action. A guide plate for the scrapers is used to insure the scrapers position and prevents them from sticking and breaking. The driving pulley can be belted up parallel or perpendicular to the length of the economizer.

The foundations required for these economizers are comparatively simple. This is due to the fact that the machines

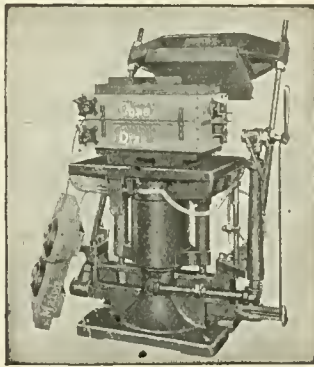

All kinds of Molding Machines, for castings ranging from the lightest hardware to the

Plates for Tunnels

in flasks 26 in. x 79 in. x 18 in., at the rate of THIRTY TONS A DAY.

Patterns on Draper-Tabor Hand Rammed Machines never wear down as in other machines of the stripping plate type. All wear is automatically taken up.

SEND FOR CATALOGUE

The Tabor Manufacturing Co.
18th & Hamilton Streets
Philadelphia, Pa.

Chicago Office: 30-32 S. Canal St.
49, Deansgate, Manchester, England
Fenwick Frères, Paris
Schuchardt & Schutte, Berlin

are so constructed that the parts themselves contain the rigidity that would otherwise be required in the foundations. The fact that taper metal to metal joints are used also eliminates the necessity of building more rigid foundations, as there are no gaskets to loosen and leak if the foundations spring slightly.

Two general types of economizers are made by the B. F. Sturtevant Company, the "Standard" and "Pony." The "Standard" is built in sections containing pipes from four to twelve wide, the staggered system of pipes making it possible to build sections of an odd as well as an even number of pipes. The "Standard Economizer" is adaptable to power plants of almost any size, but is more commonly used for boiler capacities of 350 horse power and over. The "Pony" type, as its name implies, is smaller and is more adaptable to power plants of three hundred and fifty horse power or less.

In cases where the feed water contains foreign substances the owners have found these machines to be especially valuable owing to their accessibility and ease of cleaning.

An illustrated catalogue describing the Sturtevant Standard and Pony Economizers is issued by the B. F. Sturtevant Co., Hyde Park, Mass., and is of interest to all steam users.

It will be sent to any one who writes to the company for a copy.

The Cleveland Twist Company, of Cleveland, Ohio, have just issued a standard size and very well illustrated catalogue showing their make of twist drills, reamers, taps, mill cutters, etc. There is a good index, both classified and also by list numbers. The half tones are excellent and in many cases are full size. The size and price of each article is given and a code word for ordering by wire. A very ingenious tool is the oil tube drill with long and with short set for use in turret lathes and the combination tap and drill is a neat little device which facilitates work. The Cleveland Twist Drill Company will be very happy to send this useful catalogue to anyone who is interested enough to write to them for it.

The Locomotive Fireman's Brotherhood will hold their biennial convention at Buffalo, N. Y., in September next and the prospects are that it will be the largest meeting the brotherhood have ever held. The people of Buffalo do not seem to have appreciated the value of the convention to their business interests and so much apathy was displayed that other towns tried to secure the convention long after the decision to go to Buffalo was made. This appeared to touch the pride of the Buffalonians and of late they have displayed all the interest that friends expected.

THE NEW BARRETT GEARED RATCHET LEVER JACK

30 Tons Lifting Capacity.

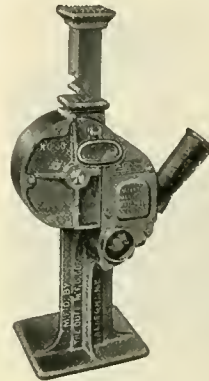

An improved QUICK-ACTING JACK for the rapid handling of loaded freight cars, Pullman cars and all heavy loads.

Has the simplicity of an ordinary Lever Jack, the leverage being specially compounded to permit EASE of OPERATION and QUICK-ACTION.

No complicated features. Cannot get out of order. Send for Special Bulletin "L" and further information.

PATENTED.

MADE EXCLUSIVELY BY

The Duff Manufacturing Co.,
Works: Allegheny, Pa. PITTSBURG, PA.

The Union Switch & Signal Co.

Consulting and Manufacturing Signal Engineers.

GENERAL OFFICES AND WORKS AT SWISSVALE, PA.

DISTRICT OFFICES:

New York: Central Building, 143 Liberty Street.

Chicago: 1536 Monadnock Building. St. Louis: Terminal Station.

GINSENG Fortunes in this plant. Easily grown. Roots and seeds for sale. Room in your garden. Plant in Fall. Booklet and Magazine 4c. OZARK GINSENG CO., DEPT. Y-15, JOPLIN, MO.

The ONLY Box WITH THE ONLY DUST GUARD

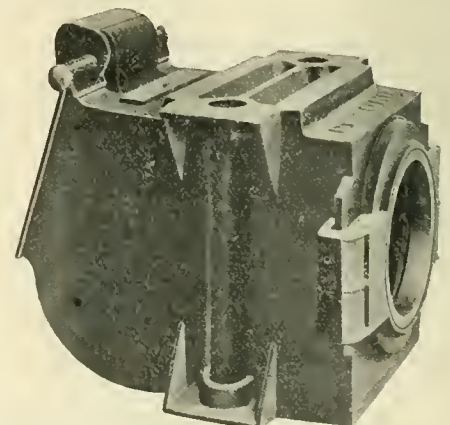

All Metal. Dust Proof. Oil Tight. Chicago McCORD & COMPANY New York WITH THE ONLY DUST GUARD

Patents.

GEO. P. WHITTLESEY

McGILL BUILDING WASHINGTON, D. C.

Terms Reasonable. Pamphlet Sent

CONTENTS.

	PAGE.
Air Brake Department.....	365
*Air Brake for Cars.....	368
Cylinder, Brake, Leakage.....	366
*Valve Handle, Returning Device.....	365
*Valve Testing Machine.....	366
Appliances:	
*Sanding Device.....	370
*Tender Lifter.....	382
*Valve Testing and Locking Device.....	372
*Wrist Pin Nut Lock.....	354
*Automobiles Climb Mt. Wash., by Angus Sinclair.....	379
Editorial:	
Boilers, Investigating Locomotive.....	358
Collisions, Locomotive, as a Public Spectacle.....	358
Railroad Discipline.....	360
Stokers, Mechanical.....	359
Ton Hours.....	359
Front Ends and Steam.....	353
General Correspondence.....	355
Locomotive:	
*Growth of the, by Angus Sinclair.....	345
*4-4-2 for Pennsylvania Lines.....	343
*2-6-0 for St. Joseph & Grand Island.....	345
*4-6-0 for Toronto, Hamilton & Buffalo.....	363
Names of parts of.....	362
Personals.....	375
*Product of Galena Signal Oil Co.....	372
Questions Answered.....	361
*Shoes, Method of Laying Off, and Wedges.....	355
*Signals and Signalling, by George S. Hodgins.....	351
Standards, Revision of.....	380
Valves, Test for, Cylinder Packing, etc.....	356
Wheels, Care of, on Boston Elevated Railroad.....	382

Railway and Locomotive Engineering

Copyright by Angus Sinclair Co.—1904

A Practical Journal of Railway Motive Power and Rolling Stock

Vol. XVII.

174 Broadway, New York, September, 1904

No. 9

First Trans-Continental Race With Mail.

Among the most thrilling romances of early rapid transit of mails in America was a race over the continent in

Joseph the most westerly point of railroads in ten days. It was a very hazardous bet, but he secured the assistance of William H. Russell, who represented a company engaged in

tense interest and all Sacramento turned out to see the start which was made at noon. The first section of the race was made by "Border Ruffian," the private saddle horse of Mr. Miller with



TYPICAL BLOCK SIGNAL TOWER ON THE NEW YORK CENTRAL & HUDSON RIVER RAILROAD.

1860. At that time a strong lobby was working on Congress trying to secure \$5,000,000 for carrying the mails overland from New York to San Francisco. Secretary of War Floyd was bitterly opposed to the scheme and made a bet of \$200,000 that he could put on a line that should make the distance of 1,950 miles between Sacramento and St.

transportation over the continent. Russell was ably assisted by A. B. Miller who arranged for a special pony express and purchased 300 of the fleetest horses he could find to perform the work.

The start was made from Sacramento on April 8, an early part of the season for such a feat. The race excited in-

Billy Baker as rider. He bounded away toward the foot hills of the Sierra Nevada, and made his ride of twenty miles in forty-nine minutes. The snows were deep in the mountains, and one rider was lost for several hours in a snow storm; and after the Salt Lake valley was reached additional speed became necessary to reach St. Joseph on

time. From here on all went well until the Platte was to be crossed at Julesburg. The river was up and running rapidly, but the rider plunged his horse into the flood, only, however, to mire in the quicksand and drown. The courier succeeded in reaching the shore with his mail bag in hand, and traveled ten miles on foot to reach the next relay. Johnny Fry, a popular rider of his day, was to make the finish. He had sixty miles to ride with six horses to do it. When the last courier arrived at the sixty mile post, out from St. Joseph, he was one hour behind time. A heavy rain had set in, and the roads were slippery. Two hundred thousand dollars might turn upon a single minute. Fry had just three hours and thirty minutes in which to win. This was the finish of the longest race, for the largest stakes, ever run in America. When the time for his arrival was nearly up, at least five thousand people stood upon the river bank, with eyes turned toward the woods from which the horse and its rider should emerge into the open country in the rear of Elwood—one mile from the finish. Tick, tick, went the thousands of watches! The time was nearly up! But nearly seven minutes remained! Hark! a shout goes up from the assembled multitude. "He comes! he comes!" The noble little mare, Sylph, the daughter of little Arthur, darts like an arrow from the bow and makes the run of the last mile in one minute and fifty seconds—landing upon the ferry boat with five minutes and a fraction to spare.

For an Engine School.

Another step in the direction of technical education has been made in the city of Dresden in the establishment of a school for locomotive driver apprentices. The initiative was taken by the Locomotive Drivers' Association of Saxony, which succeeded in interesting the members of the Dresden City Council in the scheme, as well as the directors of the technical school and the administration of the Royal State Railroads. The school is for apprentices between twenty-five and thirty years of age who are employed in the Dresden car shops. Among the subjects taught are German, arithmetic, graphics and the mechanism of locomotives.

In an article published in a scientific journal in 1845 advocating the instruction of drawing for mechanics, the argument is made that learning the art of delineation raises the minds of men above low vice and degrading amusements. On that account the peoples rules are enjoined to provide increased facilities for teaching drawing.

Growth of Locomotive.

BY ANGUS SINCLAIR.

(Continued from page 348.)

ADMITTING AIR ABOVE THE FIRE BOX.

The condemning difficulty with all arrangements for admitting air above the fire has been want of proper means of regulation. At one time the quantity of air admitted would be so near right that smoke would be prevented, so long as the rank gases were distilling from the coal, but when that ended the amount of air would be too profuse, lowering the temperature of the furnace and wasting fuel to heat a superfluous volume of air. Clarks' jet, Fig. 64, already alluded to, was the most successful appliance ever tried for the admission of air above the fire, because the supply could be regulated by a little care on the part of the enginemen.

HEAD'S FIRE BOX.

A fire box that displayed ingenuity of design was that shown in Fig. 65, pat-

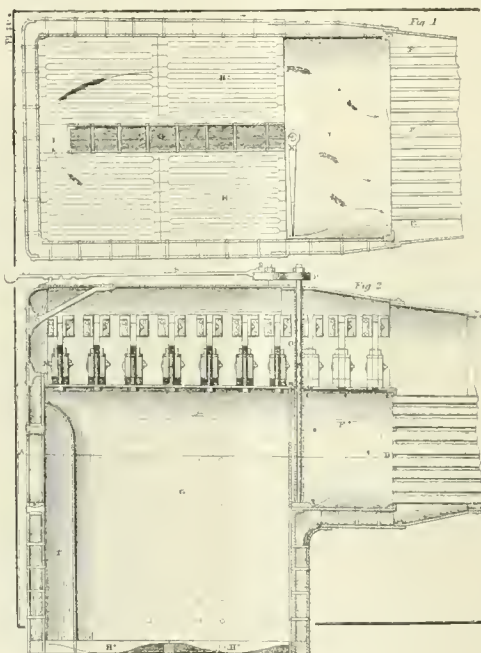

HEAD'S FIRE BOX. FIG. 65.

ented by S. H. Head, of Boston, in 1859, and applied to engines on the Fitchburg Railroad. As will be seen by the engraving, it had a mid feather cutting the fire box in two longitudinally with independent fire door grates and ash pan for each side. There was a short combustion chamber with a damper, K, which could be operated to close one side of the fire box. The idea was to close the side of the box when firing was going on, so that the products of combustion had to go around the mid feather. It was a pretty scheme in the estimation of the inventor and gave the fire gases a long journey, but somehow railroad master mechanics generally thought it called for too much manipulating.

EATON'S BOILER.

Fig. 66 illustrates a coal burning boiler designed by Richard Eaton, of the Great Western Railway of Canada. The fire box had a water arch projected from near the top of the back sheet and extending downward below the lower row of flues. A notable feature of this boiler was the smoke stack which had a series of flounces intended to regulate the draft. There was also a tubular feed water heater in the smoke box.

ROGERS COAL BURNING BOILER.

The boiler illustrated in Fig. 67 was that advocated by the Rogers Locomotive Works for coal burning. Its leading features were a fire box with shaking grates and a rather long combustion chamber. The grates were the invention of Hudson & Allen and that with the other parts of the combination were highly popular for a few years. An engine thus equipped belonging to the Great Western Railroad of Illinois had one set of grates in constant use for three years. A peculiar feature of these engines was the tubular feed water heater shown in the engraving. The shaking grates was the only element in this pioneer coal burning boiler that became a permanent attachment.

BALDWIN'S COAL BURNING BOILER.

The coal burning boiler made by the Baldwin Locomotive Works, shown in Fig. 68, had an unusually large fire box, a cast iron deflector at the opening of the combustion chamber which contained what the builders called a transverse diaphragm provided for the purpose of thoroughly mixing the gases while maintaining the igniting temperature.

In this connection it is well to mention that M. W. Baldwin was one of the first makers of locomotive boilers to take the stand that with careful firing no extra attachments were necessary to make an ordinary fire box burn bituminous coal satisfactorily. The transverse diaphragm in the combustion chamber of his coal burning boiler would have been difficult to maintain and the annoyance resulting would probably help Mr. Baldwin to the conviction that special smoke preventing appliances were a superfluity.

NORRIS COAL BURNING BOILER.

A coal burning boiler patented by Septimus Norris and built for locomotives by William Norris & Son, had several very curious features. The fire box was unusually long and had a moveable bridge wall and water grate. An opening at the back end of the grates was covered by a moveable plate which acted as a dump grate. The length of fire box proper and of the combustion cham-

ber was regulated by the position of the water bridge which could be advanced or drawn back by lengthening or shortening the water grate tubes. The whole arrangement will be readily understood by an examination of Fig. 69.

DIMPFEL BOILER.

Although locomotive builders and master mechanics made some effort in the designing of coal burning boilers, those that became best known in the United States during the early days of coal burning were patented boilers pushed into use by proprietary interests. Among the best known of these was the Dimpfel water tube boiler, shown in Fig. 70. This boiler was used to a considerable extent on the Philadelphia, Wilmington & Delaware Railroad, when Mr. S. M. Felton was president. On the occasion of receiving a presentation of a silver model of the first coal burning locomotive that belonged to his company, President Felton said:

"Many years ago, while I was upon the Fitchburg Railroad, I came to the con-

and contrivances which did not stop till success was achieved. He was the pioneer in devising ways and means of making coal a successful fuel on passenger locomotives.

"In 1855 Mr. William A. Crocker, of Taunton, and myself, built at our own cost a passenger locomotive for burning coal on Mr. Dimpfel's plans. We were very sanguine of its success. But the thing was comparatively new, and engineers and firemen were used to wood. They did not look with favor upon the black, dirty coal, and there were a thousand prejudices to contend with.

"We obtained leave to try the locomotive on the Worcester and the Western railroads. We started with a heavy passenger train, and proceeded successfully for twenty or thirty miles, and began to think that the problem was satisfactorily demonstrated, when the engine began to lessen its speed, and finally it stopped.

to the ordinary gas tubular type and performed the work of steam generation just as well as when they had the water tubes.

While designers of locomotive boilers kept insisting that a long flamework was essential for the co-mingling of the fuel gases to insure fairly economical result, the Dimpfel seemed an ideal boiler, because the whole length of the tubes formed a combustion chamber. This long flamework requirement was insisted on because it was necessary with stationary and marine boilers of natural draft. It took years of experience to demonstrate that the violent blast of a locomotive mixes the fuel gases almost the instant they come together.

THE BOARDMAN COAL BURNING BOILER.

Another patented boiler which obtained a brief popularity on a few railroads in the United States, was the Boardman, Fig. 71. In this boiler a

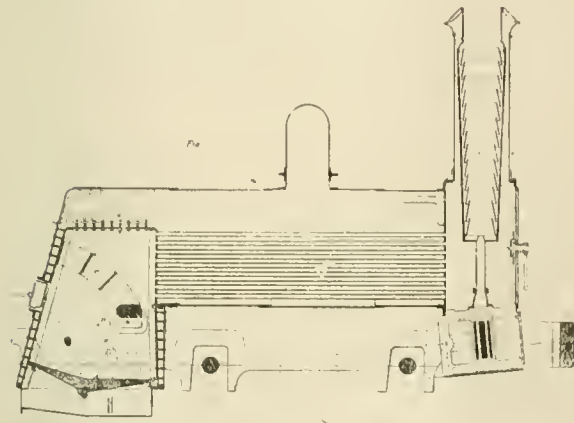

EATON'S SMOKE CONSUMING BOILER. FIG. 66.

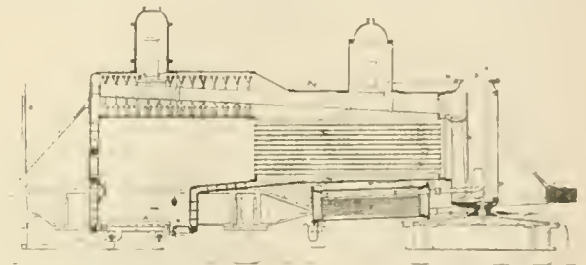

ROGERS' COAL BURNING BOILER. FIG. 67

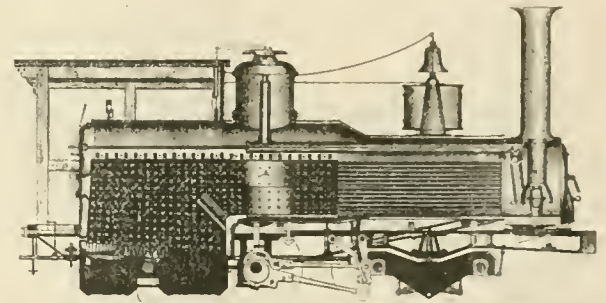

BALDWIN'S COAL BURNING BOILER FIG. 68

clusion that if railroads multiplied in the future as they had done in the past, our beautiful hillsides would be stripped of their green woods and become barren wastes, unless some other fuel than wood could be found for our locomotives. Accordingly, in 1849, I got up a locomotive for burning coal. It succeeded now and then, by a good deal of nursing, in making a trip, when everything conspired in its favor. It, however, served no really useful purpose, save as a scarecrow to those who furnished wood, persuading them that it would be a success and reducing thereby the price of wood 50 cents a cord. It was not a success as a coal burner, but it paved the way for better things.

"Railroad interests are greatly indebted to Mr. Dimpfel for his untiring zeal and persistent efforts in introducing coal as a fuel for locomotives; for, though his plans are not generally adopted, yet his efforts and his experiments turned the attention of railroad men to the subject and gave an impetus to inventions

There was a storm of indignant rage showered upon our heads by the delayed passengers. We were glad to retire from the crowd and procure another engine. Then we examined at leisure into the cause of the mortifying failure. The damper had been imperfectly secured in the open position, and the jar of the engine shook it down closing off the supply of air. The engine was condemned for this failure and we sold it at a loss of about \$8,000."

Engines with the Dimpfel boiler were afterwards made a success on the road where they had President Felton's good will, and they did fairly well on other railroads, the persistence and energy of the patentee having helped their operation during the period of first trials, when careful nursing often prevented failure. But when the water tubes burned or wore out, most of the boilers were converted

larger \square shaped flue extended from the fire box directly through the smoke box and having a plate iron partition secured across the flue at about two-thirds of its length from the fire box. A series of vertical tubes descended from the flat bottom of the flue to an ash pan below; but by the interposition of the partition mentioned, the fire gases went down through but about two-thirds of the total number of tubes and rose again through the remainder, passing thence into the smoke box. A pipe extended from the bottom of the smoke box back into the combustion chamber, as shown, for the purpose of aiding combustion with an additional supply of air. The boiler had flat sides which were stayed together.

PHLEGER'S COAL BURNING BOILER.

The Phleger boiler, Fig. 72, resembled the Septimus Norris only a little more complicated. It had a hanging

bridge, water wall and water grates, besides other curiosities. The Norris people supplied these boilers to several railroads perhaps through fellow feeling towards the patentee. The barrel of this boiler, 3ft. 10½ ins. diameter, was packed full of tubes, 230 of them, 2 ins. diameter, 11 ft. long, steam space being provided in a steam chamber of the modern steam drum order. This boiler gave an early test of excessive heating surface, the fire box and combustion chamber having been 11 ft. long, but its performance did not encourage railroad people to perpetuate the type.

The Pennsylvania Railroad Company purchased seven locomotives with Phleger boilers and ran them until rebuilding was necessary, when each one was changed to suit the taste of the me-

what may be called an endless chain of bars forming the bottom of the furnace on which the live coal blazes. The chain moves very slowly, not more than one inch a minute. At the end of the furnace the chain moves round and goes back beneath. The apparatus is fixed on a car and can be run into place on rails so that the whole bottom of the furnace can be dragged out, giving every facility for cleaning and renovating. The coal is laid in a hopper at the door and the supply of coal regulated by a sluice slide."

Like all the other smoke consuming furnaces this one soon disappeared, but it had automatic stoker features which were afterwards successfully applied to stationary boilers.

(To be continued.)

of the sill of the car windows. To the top of the post is attached a brush, which sweeps the windows of the coaches as they go past. Candor and honesty compel us to say that the bristles of the brush are placed at a suitable angle with the direction of motion so that a passenger "going up against it" would be drawn by, as an engine runs off the trailing points of a cross-over track, or to use a common railroad expression, the brush would give the careless passenger a friendly, though unmistakable "side swipe," but would not stick the bristles into him, and if he was "all in" immediately afterwards he would not be bumped or thumped or banged by the close-to-the-track structure aforesaid.

The possibilities of the side wiping brush are numerous and varied. Im-

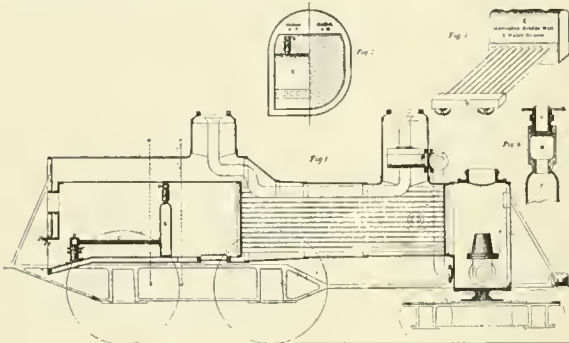

NORRIS' COAL BURNING BOILER. FIG. 69.

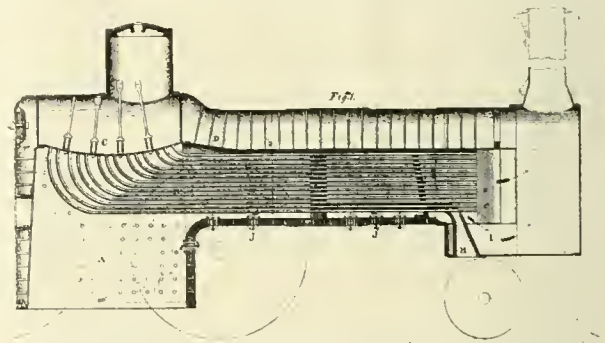

DIMPFEL'S COAL BURNING BOILER. FIG. 70.

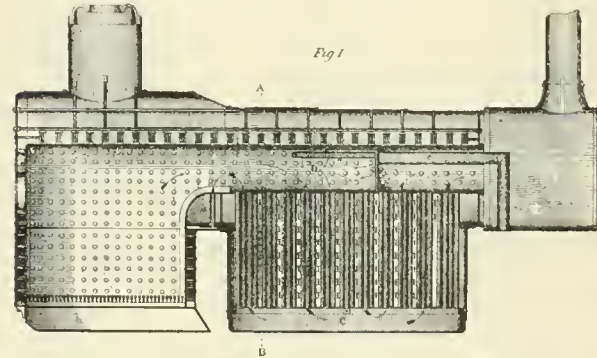

BOARDMAN'S BOILER. FIG. 71.

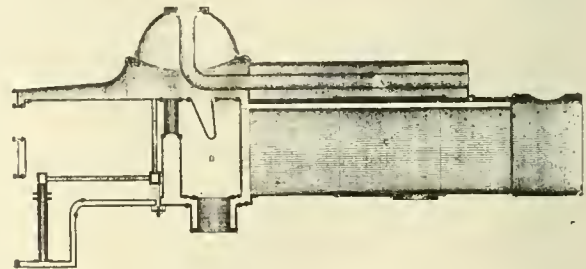

PHLEGER'S BOILER. FIG. 72.

chanical engineers of the time. A detailed description of the engines appears in LOCOMOTIVE ENGINEERING, of 1900, page 438.

CHAIN GRATE AND AUTOMATIC STOKER.

A great many of what might be called minor patents were secured on coal burning and smoke consuming furnaces between 1850 and 1870, but few of them went further than the Patent Office records. Some of them, however, attained passing newspaper celebrity and then disappeared forever. Among those was a movable chain grate arrangement which was applied to several locomotives about New York City in 1850, and was partly an automatic stoker. The New York Evening Post predicted that the invention would effectually end the smoke nuisance and said: "It consists of

Brushing Passengers.

On a certain railroad over which we have traveled, there is a most ingenious device placed at a certain point, and the operation of this device will in nine million cases to half a chance cause a passenger to hastily draw in his head or his arms if they should happen, all or singly, to have been hanging out of the car window at the time.

The wisdom of the device is beyond dispute, because if head or arms be not drawn promptly within the car window when the device gets in its fine work a structure close to the track a little farther on will cause trouble and woe for the passenger who acts not on the warning.

The device consists of an upright post, the top of which is a little above the level

agine the appearance of a man who had his right whisker suddenly set nearly horizontal by the brush, while the left hung gracefully down in the usual position, or think how a person would feel as he drew in his head with one half of his scalp neatly shampooed, while the other half remained as it was before the war.

Another advantage which this railway hair dresser can claim is that a man who had wickedly hung his head out of the car window when he ought not to have done so will present so unique an appearance after he has been "side wiped" that the conductor can readily identify him among all the passengers, and may then charge him extra for tonsorial attention by the company or can take his name and address and telegraph his wife that he will be home in due season.

Old Time Railroad Reminiscences.

BY S. J. KIDDER.

It is not for me to say that the average engineer is superstitious, but I have known lots of them who disliked to run an engine numbered 13; start out on a new time table of that date, or who indulged the notion that this engine or that conductor was their hoodoo, but while I never personally fostered such anticipations I have often wondered why it always happened when Conductor Ed. Corwin and I made a trip over the Keokuk branch that trouble invariably awaited us before its conclusion.

Ed. was one of the finest fellows and most efficient railroad men that ever manipulated a ticket punch, but, re-

obvious that Ed. must be the sponsor for our ill fortune. The branch, 43 miles in length, had few regular trains, and extras or specials, as non-schedule passenger trains were designated, were so unusual that no one along the road ever looked for them, and as a consequence I always felt somewhat timid when pulling such trains and inclined to use precaution at several dangerous places where the track was obscure, particularly at points where it wound along the base of huge bluffs rising abruptly from the river's edge which afforded but two ways to go—either follow the rails or plunge into the Mississippi. There are times, however, when prudence is forestalled by other considerations and one of them

236 gorgeously bedecked with flags and streamers indicative of both the society whose members filled the train and patriotic fervor as was evidenced by the numerous star spangled banners quietly floating in the gentle breeze. And what a load. The seats, aisles and platforms were a confused mass of humanity who good naturedly endured the situation their anticipations of the day's outing being paramount to any discomfort involved in carrying out the objects of the excursion. We had hardly stopped when Corwin in a stentorian voice called out: "All aboard," gave a signal to go ahead and the special moved gracefully out of the siding with the band playing "The Girl I Left Behind Me," and the air resonant with



Photo by Fred. Dukes, hauling, Wyo.

A WELL KEPT COMPOUND HARD AT WORK.

ardless of his numerous virtues, just so sure as we ventured out together for a trip down the branch something not covered by the time card rules and regulations was sure to turn up, though happily not of a very disastrous character, for, as a rule, with the aid of a switch rope or "frogs," interspersed with numerous adjectives, both mental and spoken, which so far as this article is concerned are not material, relieved us after more or less hard work and vexation from our dilemma.

I am not so sure but that Corwin might have attributed any possible hoodoo feature to the writer or his engine, but as the latter always behaved with becoming decorum when pulling any other conductor over this particular portion of the road, the assumption was

was the morning when by a scant margin we missed precipitating eleven coach loads of "Druids" into the murky stream. On the day in question the society just referred to had arranged a grand celebration and picnic in Burlington, including members in large numbers expected from the surrounding country, and to take care of the Keokuk contingent, Tom Tucker with the 236, and Corwin conductor, had gone to the last mentioned city for the purpose of bringing them to the scene of festivities. As a result of this I was assigned to Tom's run for the day, taking down the morning train and as the 245 rolled over the switches in Keokuk yard and brought up at the station there stood Tom on the opposite track ready to pull out on our arrival. the

joyous shouts as the train receded from view of the throng who had gathered to see them started on their journey. Following their departure I cut loose, went to the round house and some half hour later, as the 245 was being turned on the table, a telegram was received to the effect that the 236 had broken down at Middle Lock siding and calling for another engine. Mine being the only available one at the particular moment, I was ordered to relieve the disabled 236 and as soon as possible reached the point where Tucker with his broken down tender stood waiting for succor. Some time was consumed in getting ready to proceed as the 236 was disrupted to the extent that she could not be moved; as a consequence we were compelled to pull the train

back to another siding where the 245 could be attached to the head end. These preliminaries were performed with reasonable dispatch, the passengers meantime becoming uneasy as the time slipped away and the hour of the parade in which they were anxious to participate was fast approaching. When about ready to pull out the committee in charge and our superintendent came up to the engine to urge a fast run, the super. emphasizing the request by an order to "turn her loose." This I was quite loathe to do, but considering the source from which the directions emanated, together with the fact that the superintendent would be aboard the train his instructions were carried out.

From our starting point for some four miles the track was at river grade along the flat bottom land flanking the stream over which the engine attained a speed of some 45 miles an hour. Leaving the flat the track curved to the left and at the same time entered a shelf perhaps 80 rods in length, cut along the face of a high, precipitous bluff on the river side of which was a vertical retaining wall, the road bed being some twenty feet above the water. As we rounded the curve giving a view along the tangent ahead there suddenly appeared a "turtle" car loaded with steel rails which the section men were pushing in our direction, but which, upon seeing us, they suddenly abandoned and rapidly scampered up the track intent only for their own safety and to reach a projecting headland extending into the river beyond the wall. Upon seeing the obstruction I shut off, applied the brakes, opened the sand valves and reversed, driver brakes being a luxury not afforded at that time, and a moment later the fireman and myself were occupying the tender steps intently looking for a place to alight as the chances appeared more than favorable that when we struck the car, which was sure to happen, the engine and cars would be precipitated into the river. The train was rapidly slowing up, but when I did step off shortly before the collision, the train meantime moving about fifteen miles per hour, it was a mooted question where I was going to bring up as the space between the side of the tender and the edge of that bank wall was not more than four feet. My equilibrium was fortunately maintained, however, and just as I stepped there was a crash and shortly after the train came to a standstill with every wheel on the rails. Quickly reaching the engine it was found that when the collision took place the ends of the rails had been driven through the pilot, breaking out two of the slats, the rail ends passing under the bumper beams bringing up

against the cylinder saddle. The rails then slid over the car permitting it to come against the pilot when it was moved along with the engine until it came to a stop. Meantime the rail projecting far over the forward end of the car threatened every moment to drop to the track, but fortunately were supported by the car until the stop was made, when the car axles collapsed and the projecting ends of the rails settled to the ties. This condition I anticipated would take place while the train was still moving and could hardly have failed, had it occurred, to have made a heterogenous mixture of Druids, railway equipment and Mississippi river water, the dire results of which can only be conjectured. Willing hands quickly removed the obstructions and Burlington was reached, spite of the delays encountered, in time for our wards to take their assigned place in the procession.

Later in the day, learning that we were expected to see the Druids home that evening, Corwin and the writer had a private seance and concluded that as a matter of precaution against further trouble one of us had better be sick, but the indisposition proposal did not produce hoped for results for our superior informed us that no extra men were available and we must take the special to Keokuk. After supper I strolled down to the engine house, examined the new pilot slats to see if the lampblack and oil on them was dry, and not long after backed down to the Union station. Pulling out at 7 P. M. we proceeded 19 miles down the road to Ft. Madison where we had orders to meet an extra freight train. Reaching that station we found a train of 45 cars and a side track decidedly too abbreviated to hold them and as a consequence we passed over the north switch and took the siding ourselves. Following this the freight promptly started to pull by but as the stub switch which we had just used had not been closed the engine went off the track bringing up in a cattle guard a couple of rail lengths beyond and leaving us isolated on the siding so far as the main track was concerned as the rear of the freight train extended some twenty cars beyond the south switch we must utilize to regain the main line.

At first sight the situation appeared somewhat discouraging but an investigation disclosed a plan to dispose of that portion of the freight blocking our way and that was to open the train sufficiently to get control of the switch. The next move was to back our train as far as possible which would give the 245 a space of about 150 feet in which to work. With the tender against our train a switch rope was at-

tached to the side of the rear truck frame and the opposite end to a box car which had been uncoupled from the car ahead; then, in the limited space the engine could move, we were enabled to give the rear of the freight train sufficient momentum to clear the switch so that the engine could get onto the main track. Then began the work of peddling out the cars on the numerous side tracks which abounded in the lumber yards and which was finally accomplished. Next, the house track was cleared to afford passage for the night express past the disabled engine and, following a few other preliminaries, we coupled to our train and proceeded to Keokuk without further incident or delay.

Not long after the superintendent, in speaking of the various mishaps Corwin and I had sustained in our trips over the branch, remarked in a nonchalant way that he did not believe it was to the company's best interest to send us down there any more in company. Whether the remark was made in earnest or in jest I never knew, but, be that as it may, while I made many future trips over the Keokuk branch the one just related was the last with Ed. Corwin as conductor.

The Baldwin Locomotive Works, of Philadelphia, have devoted No. 47 of their Record of Recent Construction to a description of their exhibit at the Louisiana Purchase Exposition at St. Louis. The pamphlet, which is uniform in size and style with other publications of the series, is in the opening pages devoted to a description of the works and some remarks on the evolution of the locomotive as built at these well-known works, from 1832, when "Old Ironsides" was turned out, up to the present time. The exhibit at St. Louis contains some typical engines, among which may be mentioned a balanced 4-4-2 locomotive built for the A., T. & S. F., a 4-4-2 for the Q, a 2-10-2 for the Santa Fe, a 4-4-2 with Vanderbilt tender for the C. & A., a 4-6-2 for the U. P., and another for the Frisco System, two 4-8-0 for the Norfolk & Western, a 4-6-0 and a 4-4-2 for the same road, a heavy consolidation for the Lackawanna, a mogul for the M., K. & T., and a 2-8-0 for the Southern Pacific.

Judge Bradford has filed a decree in the United States District Court dismissing the bill of complaint in the suit of Percy H. Brindage, of New York, against the Lobdell Car Wheel Co., of this city. Brindage set forth that he organized the National Car Wheel Co. into which car wheel manufacturers were to be merged, and that the Lobdell Car Wheel Co. agreed to dispose of its plant and business for \$1,500,000, but failed to do so. The Lobdell Works will continue as an independent concern.

Suburban Engine for the Long Island Railroad.

The Baldwin Locomotive Works of Philadelphia recently supplied the Long Island Railroad, of which Mr. Phillip Wallis is superintendent of motive power and equipment, with some suburban tank locomotives of the Prairie or 2-0-2 type.

The cylinders of these engines are 18x26 ins. and the driving wheels are 63 ins. in diameter. Balanced slide valves are used, and they are driven by ordinary indirect motion. The engine weighs, all told, about 188,815 lbs. and it is distributed so that the drivers carry 130,365 lbs., the front truck 23,910 lbs. and the rear truck about 34,540 lbs. The calculated tractive effort which this engine can exert is about 22,700 lbs., and the ratio of tractive effort to adhesive weight is as 1 is to 5.7, which shows

tanks fill and preserve a uniform water level between all three tanks.

The boiler is a straight top one and carries 200 lbs. pressure. The heating surface from fire box is 137.4 sq. ft., that from the tubes is 1,684 sq. ft., making a total of 1,821.4 sq. ft. The tubes are 249 in number and each is 13 ft. long. The diameter of the boiler at the smoke box is 60 ins. A few of the principal dimensions are appended for reference.

Cylinder—18x26 ins.

Boiler—Thickness of sheets, $\frac{5}{16}$ in.; staying, radial
Fire Box—Length, 109 ins.; width, 72 ins.; depth, front, 55 $\frac{1}{2}$ ins.; back, 43 $\frac{1}{2}$ ins.; thickness of sheets, sides, $\frac{3}{16}$ in.; back, $\frac{3}{8}$ in.; crown, $\frac{3}{16}$ in.; tube, $\frac{1}{2}$ in.; water space, front, 3 $\frac{1}{2}$ ins.; sides, 3 ins.; back, 3 ins.

Tubes—Wire Gauge, No. 11; diam. 2 ins.; grate area, 54.5 sq. ft.

Driving Wheels—Diam. outside, 63 ins.; journals, 8 $\frac{1}{2}$ x12 ins.

Engine Truck Wheels (Front)—Diam. 36 ins.; journals, 7x12 ins.

Engine Truck Wheels (Back)—Diam. 42 ins.; journals, 7x12 ins.

is capable of lifting a freight car body off its trucks, thus saving a large amount of jacking up. The lifted car body may be transferred from trucks on one track to another set of trucks on an adjacent track. These cranes also lift and unload car wheels, axles, etc. The usual method occupies four or five times as long as this machine requires to do it. It would require an average gang of from five to ten men to perform the work. The "Labor Boss" is a highly valued machine.

Another neat and original device is an arrangement for deep ash pit-pans made to fit into the ash pit and form a receptacle sufficiently large to take the dumpings of two or three engines. From the pit, these pit-pans, when filled, are lifted by the "Labor Boss," and by a neat arrangement the drop end in the pan is opened, spilling the contents of the pit



SUBURBAN LOCOMOTIVE FOR THE LONG ISLAND RAILROAD.

Phillip Wallis, S. M. P. and Equip't.

Baldwin Locomotive Works, Builders.

that these Long Island engines are very sure footed passenger train pullers.

The wheel base is 31 ft. 8 ins. over all and the rigid base is just 14 ft. All the wheels are flanged and all are pretty evenly spaced which, though it does not increase the tractive power, adds to the appearance of the machine.

The tank has a capacity of 2,875 U. S. gallons. The man hole is placed as usual at the back, and water which enters the rear portion of the tank, finds its way to the two tanks on the running board by means of large water pipes, one of which may be seen, in the illustration, under the cab. There is a vent pipe on each of the front tanks leading up close between the pair of front windows on each side. These vent pipes allow the escape of air as the front

St. Augustine Shops of the Florida East Coast Railway.

To a person visiting the shops of the Florida East Coast Railway at St. Augustine, Fla., the principal attracting features are the "Labor Bosses," as the 5 and 10 ton self-propelling cranes made by the Michigan Machine Co. are popularly known. The capacity and convenient utility of these two machines permit them to do about all the work around an engine house and car shop that would usually be performed by an ordinary gang of laborers. The self-propelling feature of these machines allows them to be used in light switch engine service, such as moving a car, loaded with shop material, from one point to another; hauling a car or dead engine from one track to another, etc. The heavier crane

into the car placed on an adjacent track for that purpose. This arrangement is very neat and cleanly, there being no leaky hose or soggy ground found around the ash pit as is too generally the case.

The Florida East Coast Railway, being remote from the northern manufacturing centers, finds one of its greatest hardships is the payment of freight on material brought to the St. Augustine shops. This throws them largely on their own ingenuity and resources, and consequently they are obliged to help themselves by designing methods and devices for the home manufacture of materials used. As a result, a neat brass foundry has been built and is in successful operation. Although the foundry is small, two dome caps from dismantled boilers give sufficient capacity to do the

entire brass work for the system. Packing rings for pistons, valve stems, etc., are also made in this foundry. Substantial claim is made that hot brasses have been largely reduced since the installation of this small foundry, and, in fact, trouble from hot boxes on the road has been almost eliminated. This is a great achievement when one considers the sandy and hot country through which the Florida & East Coast Railway runs.

Home manufacture is further extended to the making of steel springs for the engines and cars. The railroad buys its bar steel and works it into leaves. These leaves are annealed by wood fires, and are tempered in an oil bath cooled by circulating water and a cold air blast. Special forms are supplied for bending and shaping the leaves ready for incorporation into the spring. A system of air cylinders is used for compressing the hot bands on the leaves, thus finishing the spring. A uniformly better spring is thus said to be procured.

While not distinctly original, still these shops enjoy the increased advantage of high speed steel tools. By their well known efficiency, a machine is actually made to gallop instead of walk as in the earlier practice with tools of ordinary steel.

The F. E. C. engines are never laid up for fire turning, so G. A. Miller, superintendent of motive power, tells us, as tires are never turned on the wheels, they being pressed off their own wheels and fastened to dummy, driven wheels expressly made for that purpose. There are but two sizes of driving wheels used on this road, although a third size is just now making its appearance on 10 fine new Atlantic type engines which have just been received by this road. These engines are equipped with piston valves and all modern appliances, including a full complement of engine brakes and electric headlight.

Feed water is the most troublesome element with this road in the operation of its locomotives. A set of flues and fire box has a life of only seven or eight months. At the end of this time they must be replaced. There is a glorious future and an ample fortune ahead on this road for the man who will supply an entirely satisfactory and efficient water purifier at a reasonable cost.

Locomotive Sander for Wet Sand.

An arrangement for using wet sand, or dry sand for that matter, has been recently patented by Mr. George M. Schwend. He claims to be a constant reader of RAILWAY AND LOCOMOTIVE ENGINEERING, is a practical locomotive engineer, and a member of Division 436 B. of L. E. Mr. Schwend lives at Birmingham, Ala. He writes us that he has had one of his sanders in operation on a

locomotive since the beginning of the year.

Our illustration, taken from patent No. 752,598, shows the construction of apparatus. The interior of the sand box is provided with a spiral coil of pipe which passes down near the walls of the box and terminates in two nozzles or jets which discharge into the sand pipes, marked C2. This pipe leading from the cab, supplies live steam to the sand nozzles, C4, and facilitates the movement of the sand if the pipes should become clogged or stopped in any way. A valve and suitable T connection is shown at F, which cuts off the flow of sand to the forward driving wheels and forces it, by the aid of a broad flat jet of steam, to pass into the back-up sand pipe.

The fundamental idea in this sander is the use of wet sand. If the sand is not wet when it is put into the box it is certainly wet when it reaches the rail. The use of wet sand, therefore, does away with all sorts of sand drying ap-

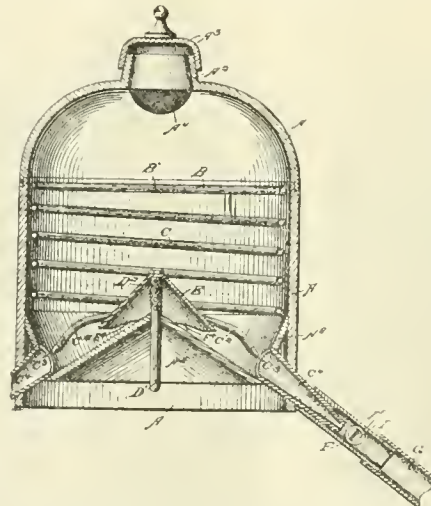

SAND BOX FOR USING WET SAND.

pliances and a patent has been granted in five countries to the inventor.

By reference to the illustration a circular pipe, marked B, can be seen at the top of the box. This pipe runs around the wall of the box and is perforated at intervals. Another pipe enters from the bottom, marked D, and this vertical pipe is perforated at its upper end, but is covered over by a cast iron hood, E. Both these pipes are supplied with water from the same source and the operating valve is in the cab. The object of the hood, E, is to prevent sand caking on or clogging up the perforations in the water pipe.

When it is desired to sand the track the water valve in the cab is opened and, preferably, hot water is turned on, which flows out of the vertical pipe, D, in a good stream and so practically undermines the sand in the box and washes it into the sand pipes, and at the same time water is discharged through the

openings in the uppermost pipe, B, which soaks down through the mass and helps on the good work. In fact, the whole thing works something like a placer mine in the far West.

In winter the valve regulating the entrance of steam to the coil, C, can be "cracked" sufficiently to prevent the damp or wet sand freezing, and the resulting drip would not cause any appreciable flow of sand, but would keep the sand pipes clear. If an engineer ran out of sand on a trip, and was careful not to get sand containing stones or large gravel, he could take it anywhere along the road where sand was to be found. There is a coarse sieve, marked A, in the sand box cover.

Dimensions of Box Cars.

The Master Car Builders' committee on outside dimensions of box cars recommended the strengthening of car ends. They consider a plank lining $1\frac{3}{4}$ ins. thick on the inside of the ends of cars would be desirable. This lining to extend from the floor to the underside of the end carline. The car would, if this suggestion be adopted, have to be made sufficiently long to preserve the neat interior length measurement of 36 feet, which was the figure adopted by the American Railway Association.

Regarding the end framing, the committee was of the opinion that a reinforcement of the center posts and corner posts of the ends of cars should be made with angle plates and I-beams, though no definite design was submitted to the M. C. B. Association. The committee, however, recommended two belt rails in the side and end framing of cars.

The interior dimensions of cars as approved by the American Railway Association, viz.: 36 ft. long, 8 ft. 6 ins. wide and 8 ft. high will be submitted by letter and 8 ft. high, will be submitted by letter ballot to the members of the M. C. B. Association.

Automobilists have met with fatal accidents at railroad crossings this season and the accidents have been out of all proportion to the number of horseless vehicles using such crossings as compared with those drawn by horses. This is doubtless due to the reckless characters so often found handling automobiles. Ordinary people who have reason to use strong language toward reckless automobilists who display no consideration for the comfort and right of others are not likely to feel much regret that the pilot of a locomotive occasionally thins the ranks of unscrupulous motorists.

A mind not to be changed by place or time. The mind is its own place and, in itself can make a heaven of hell or a hell of heaven.—Milton.

General Correspondence.

Locomotive Record Board.

Our illustration shows a unique and at the same time satisfactory board intended for use in offices of general managers, superintendents of motive power, and the like, whereby the knowledge of the location and condition of power on a system may be secured with the least expenditure of time. The board shows the location of the various terminals, roundhouses, the number of stalls, storage tracks and repair shops. The topographical chart of the main line and branches is divided in three different colored parts to show the condition of each engine, whether new, good or fair, giving its number and location, and also showing where other lines intersect and transfers can be made.

The board to the left gives a summary of the classification and mileage of each division, while the larger one to the right gives the classification, class, type and service, with the number of engines in passenger, freight, switching, work or mixed service or out of commission and whether oil or coal burning. The smaller one to the right gives the total tractive power in service and in the shops on the various divisions.

The board is neatly gotten up by Mr. W. E. Symons, mechanical superintendent of the Santa Fe, who has secured a patent covering the idea and design.

J. A. BAKER.

Treat Roundhouse Foreman Fairly.

In referring to an article published in the July issue of RAILWAY AND LOCOMOTIVE ENGINEERING, entitled "Round House Foremen," it is not my purpose to criticize the statements made by Mr. George Borne, but to bring out some facts which apparently have been lost sight of by railway officers regarding roundhouse management. Mr. Borne admits that it requires a man of exceptional ability to be a successful roundhouse foreman, and that if a man is intelligent enough to succeed in this position, he is likewise capable of getting out of it.

Taking into consideration the necessary ability and trustworthiness required, the position ranks in responsibility among the best in railway service, but in compensation among the poorest. This I believe is, in the main, the difficulty of securing competent men for this position.

The above mentioned correspondent states the fact that he left a very good position as engineer at a greater salary

than that offered as roundhouse foreman and that his hours were occupied on an average, respectively, fourteen hours in service and ten hours for recreation and rest each day. He apparently accepted the position at a reduced salary of from \$25 to \$50 per month for the one idea—the honor at-

duced to accept the position. Perhaps it was this way: You were approached by the master mechanic or the official in charge and informed that you were considered to be the best man in the shop to fill a vacancy as roundhouse foreman, and while the position was extremely arduous and would require

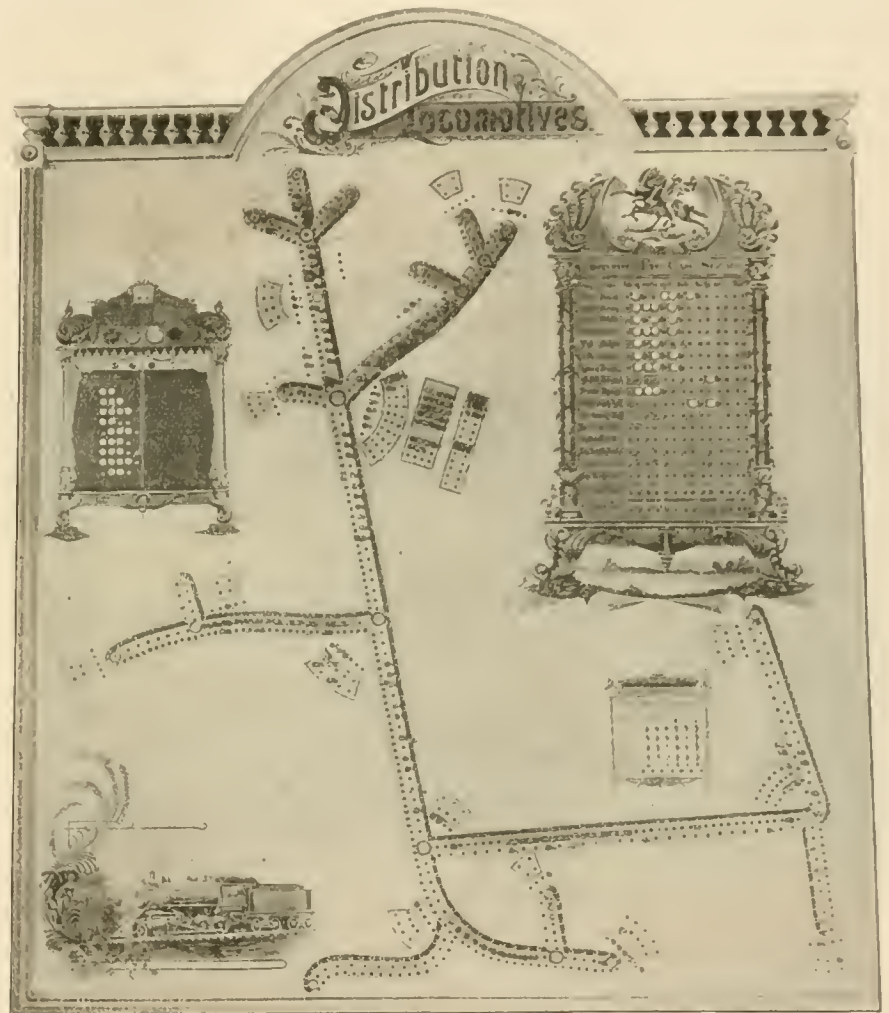

LOCOMOTIVE DISTRIBUTION BOARD.

tached to a roundhouse foreman's position. Many have been in a like predicament of Mr. Borne's and have discovered that honor like experience are expensive luxuries. When, as he states, these foremen have absolute control of their department and are compensated accordingly, then will the maintenance of locomotives between shopings be nearer perfect.

The writer can sympathize with many roundhouse foremen, especially the younger men in the business, or can understand and appreciate the circumstances upon which they were in-

patience, perseverance and foresight, that as soon as you had proven yourself capable, better things were awaiting you. You were willing to accept the position upon these grounds, and in this instance will presume that you were a success; you have proved this absolutely although never a word of praise or encouragement have you received from your superior. How about the better position that was awaiting you? There is another fellow got that, couldn't spare you from your present occupation. Then, as Mr. Borne states, you will use your brains and get out

of the position, but no doubt you will be obliged to obtain employment on another line and may have to prove your ability again before succeeding to anything better.

The writer had a similar experience and while demonstrating his competency received the magnificent salary of \$75 per month, which equaled an hourly wage of about 20 cents, considering the time in actual service. In addition to his regular duties, he had the despatching of engines and the calling of crews to look after. It is perhaps unnecessary to state that he obtained employment, in a short time, upon another road at an increased salary and with less responsibility than that of roundhouse foreman.

I do not think it possible to make good men in nine months or a year as

\$125 job—a \$124 man will not do—then we will have a less burdensome department. In closing and to illustrate my idea, I must cite an instance which occurred in New York's street cleaning department several years ago. A vacancy was caused in the superintendent's position by the death of the incumbent and the position was offered to a likely man, he would accept conditionally, one of his conditions being that he must have good men at good pay. This was agreed upon. He was appointed and during his administration the streets were cleaned better and cheaper than ever before. This idea is applicable to railroad methods. That is not to say that all employees regardless of occupation should receive exceptional pay, but employees who attend to their duties in a manner which

fail to see that the introduction of very large fire boxes is, to say the least, disappointing in its results. Not because of the fallacy of the theory of large grate surface as a theory, but rather to the condition encountered in its practical application; chief among which are limited exhaust force and inability of the fireman to supply fuel properly.

It has been found necessary as a rule to run comparatively small nozzles to increase draft at the expense of power, and work the lever down at the expense of fuel for the same purpose. If the designer figured that skill on the part of the fireman would not be an important factor in the successful operation of the modern freight engine, he was not far wrong, for they certainly afford little of encouragement or opportunity for the exercise of skill in feeding the fire, which when unskilfully done is invariably productive of results, not only unsatisfactory regarding the consumption of fuel, but is conducive to a generally wasteful and inferior performance of the engine. The chief fault of the large grate surface is the sluggish circulation of air through it, when the engine is worked at a cut-off consistent with economy in the use of steam.

With the diamond stack and proportion of grate surface used with it, we had an ideal draft, as its snappy action agitated the fire in a manner to prevent clinkering, even when stationary grates were used, and engine failures from leaky flues were of rare occurrence, for even when several flues leaked the high fire box temperature maintained when engine was working converted the water into steam that otherwise would deaden the fire as it now does in our large fire boxes, often causing complete failure of engine. Then came the straight stack and extension front, which were not by any means an improvement, rather the reverse in so far as their coal burning and steam producing qualities were concerned, as this combination effected a soft blower like draft requiring more skilful firing, and a movable grate to prevent clinkering; and while the more even, continuous draft produced by that design was by many considered a point in its favor, it burned just as much coal as the diamond stack, and was very much more sensitive to leaks in fire box, and there was no advantage claimed by the adherents of either type in so far as wear of fire box was concerned.

With the monster freight engines came a not too large fire box, but a grate area so large that the exhaust force would not create draft sufficient to produce a fire box temperature high enough to ignite those gases which are the highest heat producing elements of

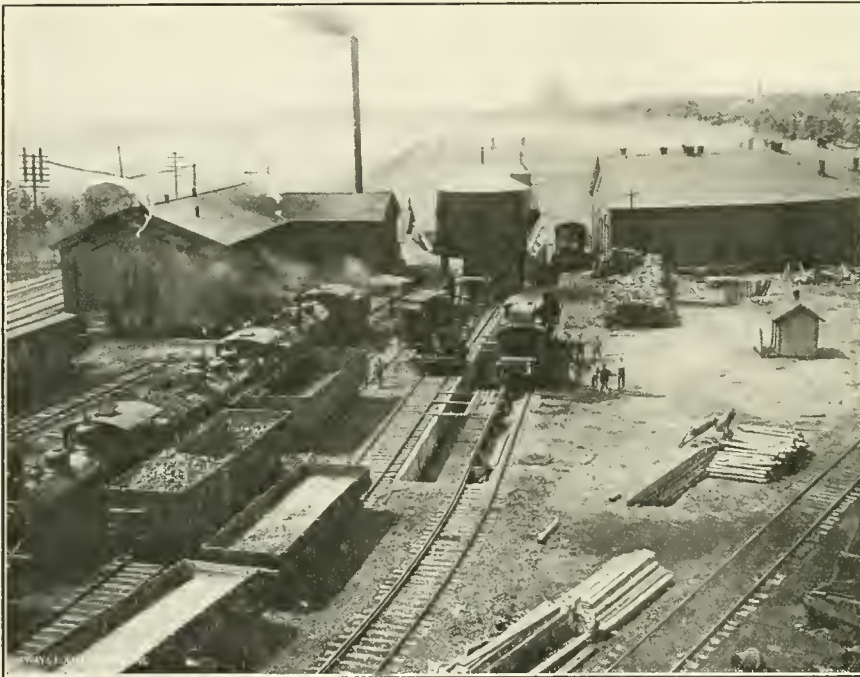

BELLEVUE, O., SHOPS, NICKEL PLATE LINE, WITH CONCRETE CINDER PIT AND CLAM SHELL COALING APPARATUS.

your correspondent mentions. This is a position that requires in addition to years of past experience, a continued study of methods and management peculiar to this department, which are arising frequently, of which our mechanical publications are publishing descriptions and illustrations. In fact it requires a great deal of self education, as it were. Many of these subjects are not to be read over and forgotten, but rather should receive much thought and in many instances memorizing. What proportion of our drafting office employees can do this or will do it?

I firmly believe that when the time arrives that our roundhouse foremen's salaries are in accordance with their duties and then place a \$125 man on a

shows an interest similar to co-operation. E. O. PALMER.

Large Grate Surface.

It was a popular belief some years ago that if fire boxes were made greater in proportion to other parts than was the practice to build them at that time it would be a decided step towards perfection in locomotive building.

Larger nozzles, making free working engines, having reduced internal resistance was one of the chief improvements sought, and the fuel economist also built great hopes upon the change.

Anyone in close touch with the operation of modern locomotives, cannot

the coal, making it so extremely sensitive to leaks that an undue number of engine failures result from that cause, while the possibility of firing the engine in a manner consistent with the best established practice is out of the question; chiefly for the reason that it is not really necessary to do so, as they will steam anyway while the fire is clean, and this fact is largely responsible for a method of firing that involves a too liberal use of the shaker bar.

The frequent disturbing of the fire keeps it uneven in depth; air passes too freely through some parts of it, striking the sheets as a cold current which causes leaks, while through other portions the circulation is so weak that clinker is formed, and this condition does not continue long before something must be done, and that something very frequently consists of leaving train out on the road and taking light engine to terminal; not always because of leaking in fire box, for it sometimes happens that fire becomes so heavily clinkered that a perfectly dry engine has been compelled to give up train. You may call it carelessness, or failure to use the proper preventatives through want of skill, etc., on the part of the engine crew, but these things do take place, and are not by any means a novelty in any locality where conditions are such as to require very large engines to remain a long time in continuous service.

Comparisons seem to prove that the most efficient service gained from any combination of parts of a machine, for whatever purpose designed, is when due regard is paid to a certain harmony of proportion of the mechanical parts composing it, as well as other factors relative to its operation, and it is the writer's humble opinion that strict observance of such requirement is as essential to guide the designer of those parts relating to the consumption of fuel as it is to the designing of parts governing the distribution of steam, or any other principle demonstrated in the operation of the locomotive.

T. P. WHELAN.

Bellvue, O.

Boring Interchangeable Car Wheels.

Perhaps there is no better illustration of modern fast methods in car and locomotive building than the method now used in boring wheels for axles. The former method was very tedious and uncertain and required long practice by the mechanics doing this work.

The pressure usually required for a 40-ton capacity car axle is now, I believe, not less than 40 nor more than 50 tons hydraulic pressure, and in fitting with the calipers the gauge would sometimes vary 30 to 40 tons too light or heavy.

Formerly the axle was made a fit for the wheel, but in the present improved method the wheels are bored for the axles, just reversing what was formerly done.

Formerly if too many wheels were bored the mills would have to shut down for the axle turners to catch up, and if not enough wheels were bored then the axle turners were hung up and either snoozed the time away or laid off.

With the advent of the high speed steels and the perfection of a boring bar that would permit of each wheel being bored precisely the same size as the preceding one, and gauges that were absolutely correct for the axles, a boy can do it now as well as a man, and thousands of wheels and axles are now turned and bored and stacked up ready to be pressed on when occasion demands, and never a pair is calipered.

made like Fig. 1, so it would always come central, was a step in the right direction, but could not be depended on, from the fact that in grinding it the operator sometimes ground one side shorter than the other, and this would throw the bar out of center also.

Fig. 2 shows the new bar made for, say, a 6 3/8 inch hole. Fig. 3 shows the bottom end view for the adjusting screw and set screws to hold the cutters. Very slight pressure is required to hold them as they fit the slots snug, and the pressure in action holds them firmly to their place. Fig. 4 shows the cutter used and four are required to the set. Fig. 5 shows the bar with cutters in place ready for service, the lower ones being slightly shorter than the top ones, doing rough and finishing cut at one operation. Fig. 6 shows the adjusting screw.

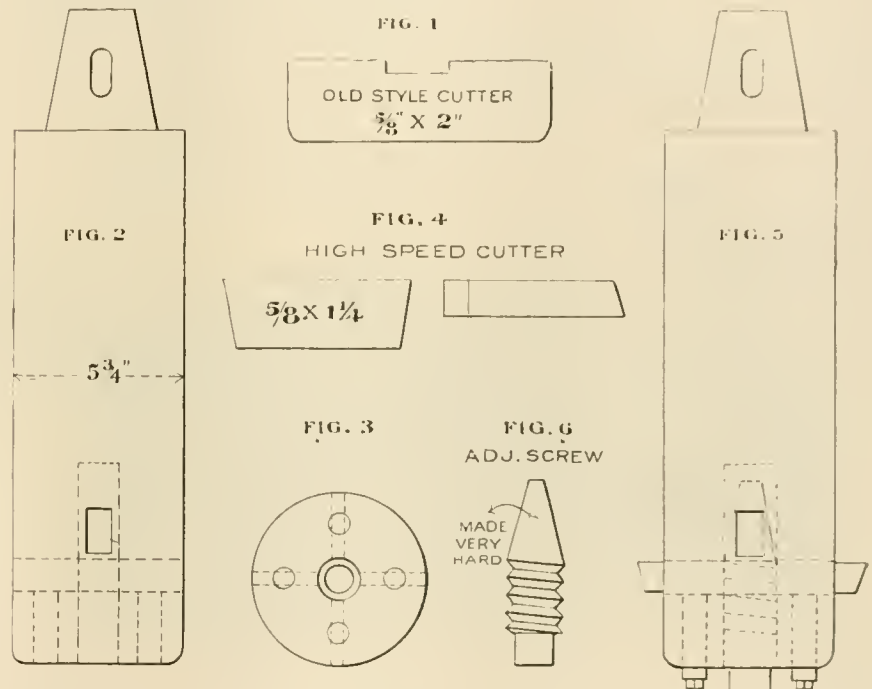

CUTTING TOOLS FOR CAR WHEELS.

There is very little variation in the pressure used in putting them on. The perfection of the boring bar had more to do with this radical change from the old method than anything else and a brief description of the process used formerly for boring wheels would perhaps not be out of place.

In the old method a cutter was used for roughing that was set in the boring bar by the operator, after being ground to size, after running this cutter through the wheel it was removed and another inserted for the finishing cut; this was set in the bar according to his eye, and if he had "a good eye" he was all right, but if not all the pressure of the cut would be on one side and very likely spring the bar out of center, or a hard spot in the wheel would cause the hole to be out of round. A finishing cutter

In preparing these cutters they are ground as accurately as possible and adjusted to size by comparison with hardened steel gauges used on the axles. If they wear small the adjusting screw is run up until they correspond to the gauges and they are ready for business again. A set of these cutters will sometimes run two months without grinding if the wheels are as soft as they should be. They are tried with the gauges every morning and sometimes oftener, for any variation that may occur from wear.

T. TOOT.

Cut-Out Valve for Engines.

Briefly my invention consists of a valve placed in the T-pipe, or nigger-head. As shown in the engraving, when the valve is in the central posi-

tion, steam from the dry pipe can pass into each branch pipe. The valve has a double face and can be made to seat either to the right or the left, and thus effectively block one or other of the branch pipes, as the case may be.

When the valve is drawn over with handle away from the stack, it prevents steam from reaching the right hand steam chest and with steam thus cut off, when a break down occurs, a great deal of disconnecting is avoided, and time is saved on the road.

It also greatly reduces operating expenses in the shop, as a large item of this expense must now be charged to reconnecting and replacing lost and destroyed parts, which were lost or broken during the confusion of disconnecting. Actual broken parts only, need to be renewed, as this cut-out valve does away with all unnecessary disconnecting.

The valve could also be arranged so as to be operated in the central saddle.

In the roundhouse this valve will be found useful in testing blows, as

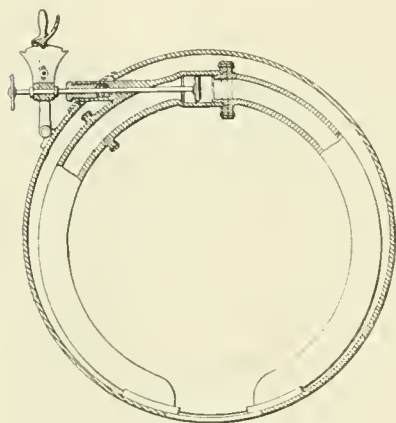

STOP VALVE IN LOCOMOTIVE
BRANCH PIPES.

steam to one side of the engine can be shut off completely while the other side is tested.

WILLIAM A. ENGLE.

132 North Coal street, Pottsville, Pa.

New Radial Crown Stay.

I am sending you a drawing of a new radial stay bolt invented by Mr. Joseph Peters and myself, a patent for which is pending. We hope you will note the advantages gained over the present radial stay.

The accompanying cut shows one radial stay with countersunk head, the other shows semicircular head, and the other shows how our radial stays look after they have been applied to the boiler. The radial stay is screwed into crown sheet of fire box. A sleeve goes over stay and is screwed down on top of the crown sheet, making a tight joint on top, preventing corrosion of threads and allowing the heads to be caulked when it becomes necessary to do so. This we can-

not do with the present radial stay. This sleeve does not take up much space and it can be made of steel tubing the size required not to exceed $\frac{1}{4}$ in. thick, $\frac{3}{4}$ in. deep, tapped out the same as an ordinary nut, with same tap as crown sheet is tapped with.

The crown sheet should be counter-bored $\frac{1}{8}$ in. top and bottom to make a good joint. This radial stay with sleeve can be applied to all boilers, if boiler is designed correctly. The holes in the crown sheet should be at right angles to the circle of the crown sheet. This will allow the stay to be applied to every hole in crown sheet, the square should be removed after bolt is finished. The sleeve can also be used for crown bar nut, the sleeve takes the place of the big cast iron thimble, giving more water space and better results.

The yoke bolt screws into outer casing or wagon top and is hammered over the same as an ordinary stay bolt. A

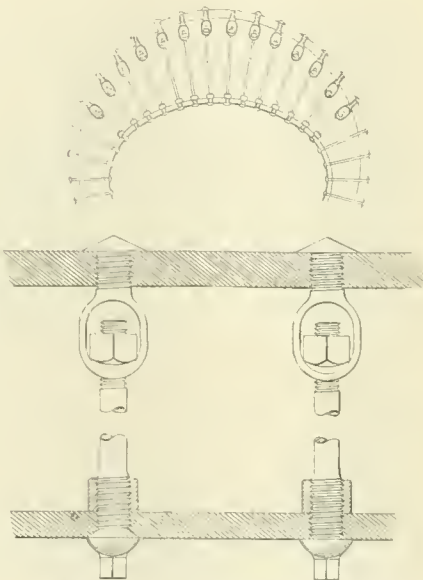

NEW RADIAL STAY FOR LOCOMOTIVE
BOILERS.

smooth bored hole in the bottom of yoke $\frac{1}{8}$ in. larger than the bolt, allows the stay to have a free clearance, the yoke counterbored for a ballbearing 12 thread nut. This ballbearing nut will allow for the expansion of fire box when engine is fired up, overcoming the breaking of the stay, which is the great trouble with the present stay. This yoke will also overcome the stripping of the boiler at the wagon top when it becomes necessary to remove stays. We know a bolt or stay of this kind cannot be removed separately, the breaking of the bolt is overcome and we can almost guarantee this stay properly applied to last the life of a fire box.

JOSEPH PETERS and JOHN COLEMAN.

Nothing is denied to well directed labor; nothing is to be obtained without it.—*Sir Joshua Reynolds.*

Reminiscences from Apprenticeship.

BY J. B. PHILLIPS.

There are some very interesting and amusing thoughts which come back to one when he attempts to recall apprenticeship days. It is a serious time in a boy's life when he comes to decide what shall be his life work. All through my boyhood days I was determined to be a railroad engineer. I lived in a lumbering town on the lake shore in Northern Michigan and had not seen a locomotive for five years, nor was there a railroad within two hundred miles. At the age of sixteen, like many another boy, I quit school under my father's protest, and he, anxious to gratify my desire to be an engineer, did the next best thing, and placed me in a machine shop where saw mills and steam boats furnished the bulk of the work. It was a red letter day with me when my father took me to the little old shop office to see the proprietor about learning the trade. I remember how he looked me over as I stood there under cross question waiting for him to decide whether he would accept me or not. He finally agreed to give me a trial and ordered me to report for work in the morning. With a light heart I turned to go away, when he called and said, "See here, my boy, your duty for the first six months will be to fire the boiler and run the engine and you will begin work at five thirty in order to have steam up at seven o'clock." This was not so pleasant, as it was in the middle of winter and lights were required until eight o'clock in the morning.

At five thirty sharp the next morning I entered the shop and the proprietor met me and forthwith proceeded to initiate me into the secrets of making steam, and I wish to say right here that it required some time to learn the secret, as our only fuel consisted of green pine slabs covered with snow and ice. They were four feet long and it took a good head of steam on my part to haul them in on an old sled from the slab pile. There was no water glass on the boiler, as such was a luxury that could not be afforded; there were, however, three gauge cocks and I was solemnly cautioned to try those gauges at least every five minutes, the other four minutes I improved by starting and stopping an old plunger feed pump, in splitting icicles and slabs, taking pains to scrape off the first coat of snow before throwing them into the yawning arch under a return flue boiler. That first morning from five thirty to seven o'clock was a strenuous one, but reinforcements were in store for me that I knew not of—there had been another boy engaged to learn the trade and he was notified to report at the

same hour I did, but he was a good sleeper and failed to show up until seven o'clock. I was at once promoted and made first engineer, while he held second place and had full charge of the slab pile axe. This gave me plenty of time to try the water, start and stop the pump, and oil the engine, which was of the upright variety and fastened to a post.

That first morning taught me a good lesson on punctuality—it pays to be on time and the man or boy who expects to succeed in life will certainly be disappointed if he does not appear promptly at the appointed time. Punctuality is the right arm of success, and many a man with a bright mind has gone through life with failure for a companion simply because he did not practice punctuality.

My assistant engineer worked a week and then quit because he did not like second place, which he forced upon himself by being late. Another boy was given his place and I had plenty of assistance. My first week was a dream in the day time and a solid nightmare the rest of the time, for I was trying the water, starting the pump, firing the boiler and attending to all the other duties of first engineer all night and every night for a week. There is not another week in my shop history of twenty-two years to equal it; there were boiler explosions that tangled me up with wheels and machinery, there were sudden awakenings caused by high and low water, until I was completely exhausted and overcome with weariness. The second week started out better, and becoming familiar with my duties I soon found time to explore my immediate surroundings. A bolt cutter was located within ten feet of the boiler and I soon became acquainted with its secret parts and had the pleasure of running it added to my duties. In those days we used nothing but lard oil, it came in barrels and had to be thawed out in winter time. You could vouch for its being the genuine article by frequently coming in contact with pieces of fat pork, which, like the recitation of the dunce, was not well rendered. It was quite a common thing to have the spout of your oil can bristle up, and invariably the spout had to be removed to get the bristle down.

Spring came, business was rushing, and men hard to get, and for that reason my services as engineer terminated three months sooner than expected and I was placed on a lathe. My first lathe work was making wooden rollers. The hemlock logs were brought into the shop with the bark on and were cut up in lengths varying from two to six feet and were from fourteen to twenty-four inches in diameter. I clamped

them on the carriage of an old lathe, caught a long auger in the chuck, started it central in one end and trusted to luck as to where it would come out at the other end. We generally had enough to turn off so that it did not matter much where it came out. After the logs were tunneled we drove shafting through them, then placed them on the lathe centers and turned them up. In the summer time when work was slack I had to sweep the shop, oil the shafting, help the blacksmith, line the cupola, and break pig iron. Nowadays if an apprentice boy is asked to do anything that is not strictly a part of the trade, the foreman is quite apt to have the pleasure of entertaining the grievance committee, but there was no grievance committee in our shop. I was the only apprentice boy and was accommodating to a fault. I have made earnest search and inquiry for the round square, the left handed monkey wrench, the straight hook, and all of the other tools so necessary for a beginner to use.

I remember on one occasion being

you didn't know." "Well, I say I didn't." "Oh! You just wait until the old man finds it out, he'll get your scalp." Oh! please don't tell him, Mr. J., I'm awful sorry. What are they, anyhow, I thought they were scrap?" "Scrap! Why boy, those were cast iron flasks for moulding propeller wheels, and they cost twenty-five dollars apiece; you'll catch it, you will, when the old man gets next." Fortunately for me, however, the "old man" did not find it out for six months, and yet, in one sense, it was very unfortunate, as expectancy and dread kept my mind constantly stirred and every time I thought of it I wondered what the old man would say when he did find it out. I had improved so rapidly that he never said anything about it and my record as a scrap breaker remained a standing joke until I left the shop.

A Western Pioneer.

Availing myself of an opportunity generously tendered me by Mr. H. J. Small, general superintendent of motive

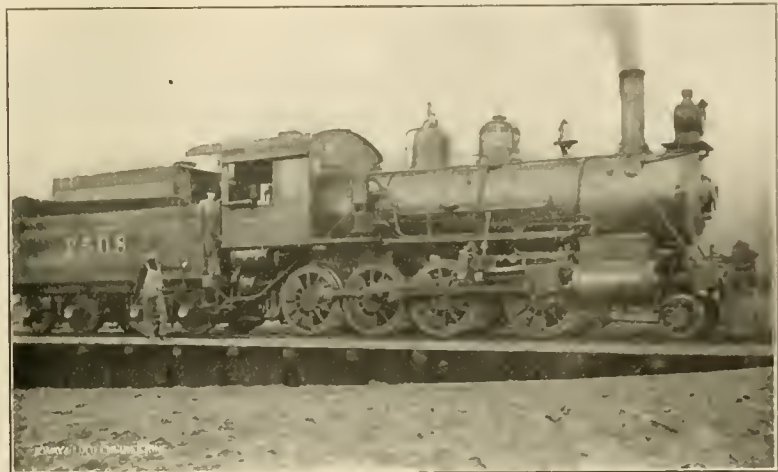

STEVENS ENGINE ON THE SOUTHERN PACIFIC.

sent out to break pig iron. After giving my best effort to break several pieces of tough pig, I finally decided to try something easy. Laying up close to the shop, and partly hidden by some wooden flasks and the growing grass, was a very large, frail casting, and being near the scrap pile I naturally thought it was waiting for the pot. I waded into it and soon had it reduced to the finest kind of cupola iron. There were two of them, and anxious to make a good showing I was about to give the second one my smashing attention when the boss moulder stepped to the door and with horror stricken face suddenly exclaimed, "Here! here! Stop that, you young rascal; what do you mean by breaking up those cast iron flasks—you had ought to be horse whipped!" "Well, but I didn't know." "Tut! tut! don't tell me that

power, I rode on a number of Southern Pacific engines on my recent trip to the Pacific coast. While I do not approve of pooling engines, I must confess that the condition of this company's power is first-class, largely because of the hearty co-operation of the enginemen with the mechanical department.

One engine particularly interested me because I was familiar with the type, having run one of the same make in the later eighties. The engine recalled to mind the well-known figure of its inventor, the lamented A. J. Stevens, of Sacramento, California. The Stevens engine, while giving way to heavier power necessitated by the increase of traffic, is still holding its own and doing excellent work.

The peculiarity about the Stevens is its valve gear, which is a modification of the Walschart gear, the motion being taken from the crank pin, and an equiva-

lent to one eccentric. Attached to the main crank pin is a crank arm which operates the transmission bar that controls the rocker arm. It will also be noticed in the illustration that the shifting link is turned in the opposite direction from that on a standard engine, and that the steam chest and cylinder appear unusually long. The fact is that this chest has two valves, one ahead of the other, and operated by two distinct and separate valve rods, coupled to the main stem by a bar whose upper end resembles a letter V, and whose lower end is attached to the crosshead. The rod controlling the rear valve is hollow and permits the rod controlling the forward valve to pass through it and the rear valve. This engine with its 20 x 30 in. cylinders and 55 in. wheel can exert a tractive effort of 29,000 lbs. easily.

These engines have given excellent service in both freight and passenger traffic, but upon the death of Mr. Stevens there were unfortunate complications regarding their construction on account of the patents covering the valve motion, so that they did not come into general use throughout the country.

They have a record for speed equaling anything of the present day. Shortly after they were put into service, Mr. Allan Manvel, then president of the Santa Fe, made the trip in a special, pulled by a Stevens engine through the San Joaquin Valley, a distance of 220 miles, in 218 minutes, including stops for water. To our friends who advocate a full throttle under all conditions, let it be said that no attempt was made to use a full throttle on this occasion. No braver men ever existed than the enginemen on the Southern Pacific, and it is commonly remarked to this day by them that no man ever lived that found the limit of speed of these engines.

The Stevens engines are the lightest on fuel, where coal is used, and, although the men were opposed to them at first—as often happens when new inventions are introduced—still they would hail with delight a return to the Stevens "monkey motion," as they used to call the engines.

J. A. BAKER.

Record of Boiler Explosions.

The American people are very lax in making safeguards for human life and limb. The ideas of liberty of action leave too much freedom to the individual in the use of dangerous appliances. This is particularly the case in the use of steam boilers. In some states there are practically no restrictions against using boilers that are in a dangerous condition. The most common form of boiler to explode is that used in saw mills where ignorant attendance and no inspection invite disaster. The *Locomotive* has published a table of boiler explosions that occurred

every year since 1879, which shows that there had been 6,769 boiler explosions in the 25 years resulting in the death of 7,295 persons and the more or less serious injury of 10,868 others. The number of boiler explosions has steadily increased although boiler material and boiler making skill has improved. In 1879 there were 132 boiler explosions reported and 383 in 1903. In 1901 there were 423 boiler explosions reported.

Renewal of Journal Collars on the Boston "L."

A unique and very effective method of renewing worn collars on journals is practiced in the Sullivan Square shops of the Boston Elevated Railway. By reason of the many and sharp curves on that short but busy line, and the large car mileage made daily the end wear of brasses and the wear of the journal collars is considerably greater than that on ordinary steam railroads.

When a collar becomes worn beyond the limit deemed safe, the axle is put

original journal, and if necessary the cap can be split off and a new one applied when end wear has again become excessive. The journal can thus be run with a good collar until the legitimate reduction of its diameter reaches the limiting dimensions.

Facts and Figures About the Illinois Central.

The passenger department of the Illinois Central Railroad, which is in charge of Mr. A. H. Hanson, as general passenger agent, has just issued an illustrated folder of practically 62 pages, called Facts and Figures About the Illinois Central. These facts and figures show the geographical, physical and financial importance of what is called the "Central Mississippi Valley Route." There is an outline sketch of the country through which it passes. All the points of interest on the line are touched on and a charming little half tone view of some striking features in each, arrests and holds the attention. There are also views of some

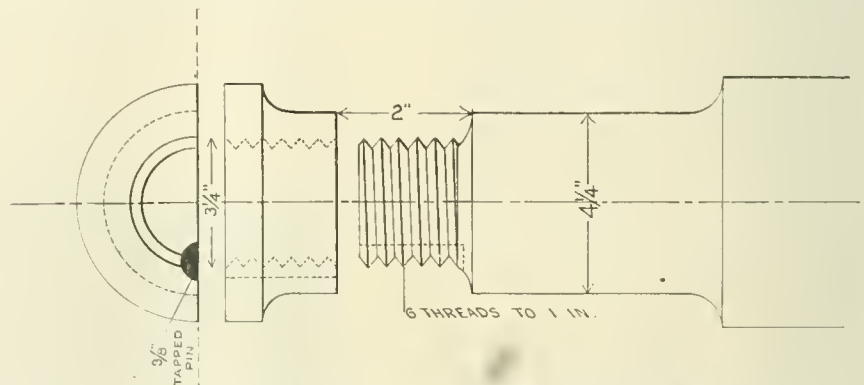

METHOD OF REPLACING WORN COLLAR ON THE BOSTON ELEVATED RAILROAD.

in the lathe and the end of the journal is turned off as shown in the sketch. For example, the diameter of a motor car journal is $4\frac{1}{4}$ ins. and the length 7 ins. The worn collar is completely turned off and a portion 2 ins. long is turned down to a diameter of $\frac{3}{4}$ ins. and threaded with six threads to the inch. A good fillet is left where the threaded portion joins journal, and what practically amounts to a cap $\frac{1}{4}$ ins. diameter with full sized collar is turned up, bored out, and threaded to suit. This cap is made smaller than the turned down journal, so that only the first thread of each will engage. The cap is heated and while expanded is screwed home so that the joint is barely discernible. In order to entirely prevent the possibility of the cap slacking off a $\frac{3}{8}$ in. hole is drilled so that half of it will lie in the cap and half in the journal end. This hole is then tapped and a tightly fitting plug screwed in, cut off and riveted over. The end cap with the collar gives a new "lease of life" to the journal and is as solid and strong as the

of that company's fast trains, locomotives and cars, and the automatic block signal system which is used.

The Illinois Central is justly proud of its new steel frame side door suburban passenger car, designed by Mr. A. W. Sullivan, assistant second vice-president, and Mr. William Renshaw, superintendent of machinery. A full and complete description of this car is given. Readers of RAILWAY AND LOCOMOTIVE ENGINEERING are familiar with the general plan of the car which provides a maximum seating capacity and puts the end door crowd collecting suburban vehicles altogether in the shade as far as duration of stops is concerned. These cars are heated by direct steam from the locomotive, the Safety Car Heating & Lighting equipment being used. Pipes are arranged under the seats which are, of course, placed across the car, and special attention has been given to securing free circulation of air so as to maintain an even temperature in the car. Speaking of this feature of the car, the Illinois

Central passenger department says: After continuous trial throughout the entire winter of 1903-4, no difficulty has been experienced in maintaining a proper temperature. Even during the most inclement weather, the absence of draughts, owing to the fact that the side doors are opened only on one side at a time and never while the train is in motion, and the less time they are opened as compared to an end door, has more than offset the greater open area momentarily exposed.

Heavy Consolidation for the Great Northern.

The Rogers Locomotive Works, of Paterson, N. J., some time ago supplied the Great Northern Railway with some heavy 2-8-0 engines, and Mr. George H. Emerson, superintendent of motive power, received them on behalf of the railroad.

The engines have 20x32 in. cylinders,

axle of the second pair with bolt and spacing piece at the bottom to facilitate removal. The hook end of this transmission bar, although allowing plenty of room for its own movement and that of the axle within it, is strongly made with stout marginal flanges like an I-beam.

The boiler has a diameter of 72½ ins. at the smoke box end. The fire box is

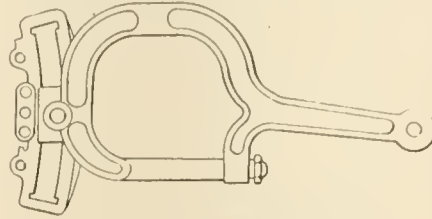

LINK AND TRANSMISSION BAR, GREAT NORTHERN RAILWAY.

what may be called medium wide, and is of the Belpaire type. The total heating surface is 2,744 sq. ft., and the grate has

Flues—No. 11 B. W. G. diam. 7 ft material steel
 Engine Truck—Style, 2 wheeled radial
 Engine Truck Wheels—Diam. 44 ins.; kind, steel
 tired, wt. in working order, 100,000 lbs. Trucks,
 diamond arch bar; wheels, diam. 36 ins.; steel
 tired.

The following notice, which speaks volumes, is to be seen in several places in the Sullivan square terminal station on the Boston Elevated Railway: "Running against others, pushing, or other disorderly conduct is prohibited. Passengers must conduct themselves with due regard to the right and safety of others."

More than twenty years ago the telephone was successfully used by divers working in vessels beneath the surface of deep rivers.

On the original location of the railroad from Jersey City to Paterson, which now forms part of the Erie sys-

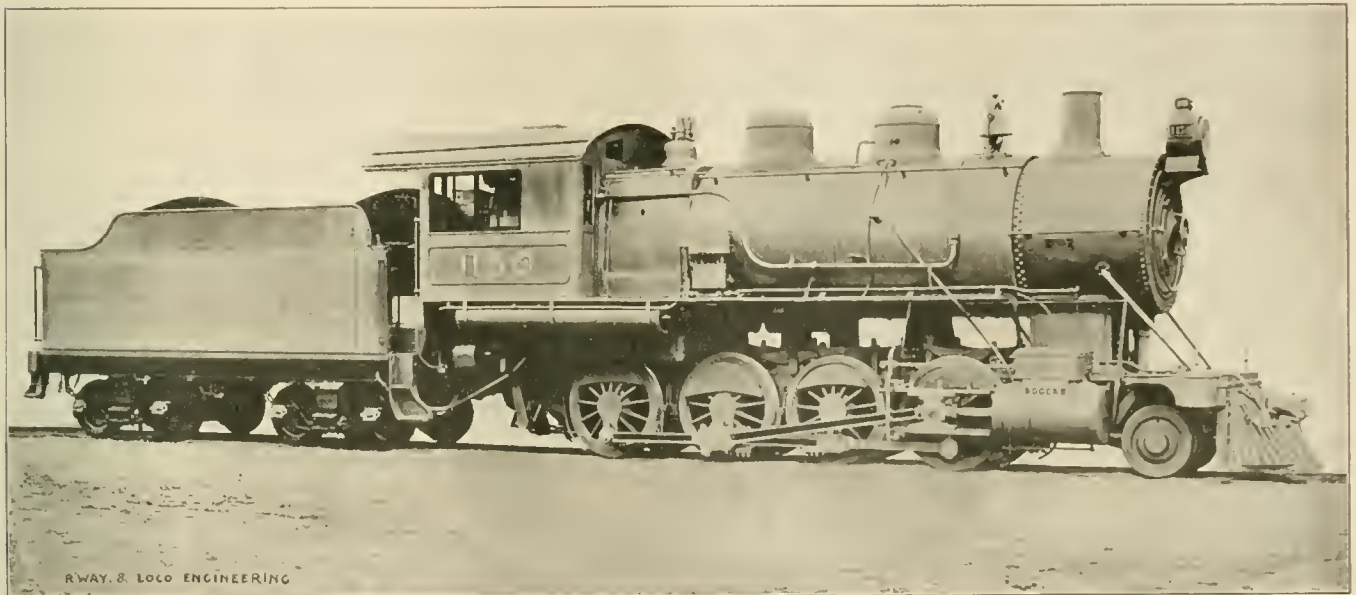

G. H. Emerson, Supt. of M. P. CONSOLIDATION FOR THE GREAT NORTHERN RAILWAY LINE. Rogers Locomotive Works, Builders

and the driving wheels are 55 ins. in diameter. The weight which is carried by these wheels amounts in all to 180,000 lbs., which gives an axle load of 45,000 lbs. The calculated tractive effort is about 41,500 lbs., and the ratio of tractive effort to adhesive weight is as 1 is to 4.3.

All the wheels of this engine are flanged and the spring equalizing follows the usual practice. The main drivers are the third pair, and the eccentrics are carried on this axle. The link block is attached to a transmission bar which passes forward to the lower pin of a rocker which has one arm above and one arm below its center. The valve gear is, therefore, indirect. The valves are ordinary balanced D-slide. The transmission bar is made of cast steel, and its back end completely encircles the

an area of 59 sq. ft. The tubes are 33t in number, and 14 ft. 8 ins. long. The back sheet is straight up and down and has two perfectly circular fire doors in it. The working pressure is 210 lbs.

The tender frame is made of 12 in. steel channels and the tank carries 6,000 U. S. gallons of water and 11 tons of coal. There is neither name, initials, or number painted on the side of the tank, so that all the tenders of this class are "strictly interchangeable." Some of the principal dimensions are given below:

- Cylinders—20x32 ins
- Driving Wheels—Diam., 55 ins; axles, material, steel; journals, 9x12 ins.; wheel base, 16 ft.; total wheel base of engine, 24 ft. 3 ins.
- Weight—On Drivers, 180,000; truck, 15,000; total engine, 195,000.
- Fire Box—Shell, steel; crown, 7½ ins; thickness, fluesheet, 5/8 in.; sides and back, 3/8 in.
- Grate—Length, 118 ins.; width, 72 ins.

tem. reverse curves were put in where space could be found conveniently, and the locating engineer explained that it was done for its graceful and picturesque effect.

In an editorial article published in the *Railroad Advocate* in 1854, strong arguments were used against the then growing practice of running trains at night. Safety and economy were sacrificed when trains were moved after sundown, insisted the writer, and the point was made that daylight is the time for work and there is plenty of it for some persons to perform their day's work.

Anxious people often magnify an evil and make it worse.—*Old Curiosity Shop.*

Railway and Locomotive Engineering

A Practical Journal of Railway Motive Power and Rolling Stock.

Published Monthly by

ANGUS SINCLAIR CO.,

174 Broadway, New York.

Telephone, 984 Cortlandt.

Cable Address, "Loceng," N. Y.
Glasgow, "Locauto."

Business Department:

ANGUS SINCLAIR, President.
FRED M. NELLIS, Vice-President.
JAMES R. PATERSON, Sec'y and Treas.

Editorial Department:

ANGUS SINCLAIR, Editor.
F. M. NELLIS,
GEO. S. HODGINS, } Associate Editors.
JOS. A. BAKER, }

Advertising Department:

Eastern Representative, S. I. CARPENTER, 170 Summer St., Boston, Mass.

Western Representative, F. B. LAWSON, 1204 Monadnock Block, Chicago, Ill.

British Representative:

THE LOCOMOTIVE PUBLISHING CO., Ltd., Amen Corner, Paternoster Row, E. C., London.

Glasgow Representative:

A. F. SINCLAIR, 15 Manor Road, Bellahouston, Glasgow.

SUBSCRIPTION PRICE.

\$2.00 per year, \$1.00 for six months, postage paid to the United States, Canada and Mexico. For other parts of the world, \$2.50 or ten shillings. Single copies, 20 cents. Remit by Express Money Order, Draft, Post Office Order or Registered Letter. Mailing address can be changed as often as necessary—always give old and new address, and if you subscribed in a club, state who got it up. Please give prompt notice when your paper fails to reach you properly.

Entered at Post Office, New York, as Second-class mail matter.

Copyright by Angus Sinclair Co., 1904.

For Sale by Newsdealers Everywhere.

The Passing of the "American" Locomotive.

A philosophical contribution to the history of the development of the locomotive engine, which we have delayed giving particulars of through want of time to review in the manner it deserves, is a paper submitted by Professor Goss, of Perdue University, presented to the American Society of Mechanical Engineers at one of the periodical meetings. The paper was illustrated by stereopticon views presenting a graphic story of the development of the engine. He said that during the early days of railroad operating a certain type was used so much that it became known as the American locomotive. That engine was carried on eight wheels, two pairs connected being the drivers and a four wheel truck in front. It made no difference whether the service was freight or passenger or whether the locomotives were in use on heavy grades or on level track, the fitness of the type was seldom questioned. The extent to which a single design was duplicated is disclosed by the fact that in the early eighties, a single establishment supplying many different railroad companies and in one year building over six hundred locomotives, employed but a single draughtsman, a condition of affairs that implied very low cost of production and maintenance.

Adherence to the American type, which met the conditions of early railroad service, made the problems of the builder few and not only kept down the cost of manufacture, but reduced the work of effecting repairs to the simplest terms. The same patterns were used over and over again, every detail being proven by service, so there was no difficulty for the users to procure duplicate parts for use in repairs. This was a great convenience in a country where the track mileage was increased at enormous bounds. The design was also well adapted to the rough track common in pioneer work, and considering the service rendered the type was and still is remarkably efficient. While the type still has an important place in service, few locomotives of its kind are now being built. Its decline is due to the fact that it will not admit of a grate of sufficient size for present day requirements and another objection is that it admits of too small tractive power for modern requirements.

The grate of a locomotive is near the source of the power and if that is restricted the power of the locomotive cannot expand. Originally the fire box of the American locomotive was restricted in width by the space between the frames and in length by the distance between the driving wheels. The width was generally 34 ins., and the length not more than 72 ins. When the necessity for increased grate area became urgent various expedients were resorted to for the purpose of promoting the efficiency of this highly popular engine. The favorite method was raising the boiler in height and diminishing the depth of the fire box so that it could be placed above the frames instead of between them, a change which permitted the grates to be widened from six to eight inches. In some cases the grate was inclined and allowed to extend over the rear axle. These changes helped to maintain the reign of the eight-wheel engine for a few years but the relief was only temporary. More grate area became imperative and other types of engine had to be designed that could provide what was wanted.

For freight engines having small wheels it was practical to employ the Wootten boiler, but in fast express passenger engines the wheels had to be made too large to permit a fire box to be extended above them, so an improved form of locomotive had to be adopted. The kind of engine that forced itself into service as a successor to the eight wheel engine was the "Atlantic type" (4-4-2), which obtained favor by its fitness to meet the required conditions. The wheel arrangement of this engine permits the fire box to be extended at both sides and lengthened to the rear providing all the grate area necessary in a convenient shape.

Still another development brought out by necessity is the "Pacific type" (4-6-2),

which has three pairs of drivers connected and one pair of trailing wheels. With these changes the engine has been steadily increased in weight and much greater tractive power obtained than what is practicable with the older forms of motive power.

Traction power being directly dependent upon adhesive weight, the eight wheel engine had reached the limit of its capacity through adhesive limitations. The adhesion of a locomotive is equal to about one-fifth of the weight on drivers. The eight wheel engine could not be operated satisfactorily with more than 16,000 lbs. upon each driver giving 64,000 lbs. for adhesion. One-fifth of that is 12,800, which was the limit of power that could be applied without causing ruinous slipping. The progressive changes made in the newer types of locomotives are such that now a locomotive has been built, having twelve wheels, which is expected to develop a tractive force of over 50,000.

In the process that goes on within the fire box of a modern locomotive it will be found that under favorable conditions each pound of coal burned will sustain one indicated horse power for a period from twelve to fifteen minutes. At a speed of ten miles per hour the pound of coal will serve to carry six tons of freight one mile. In the development of the locomotive grates have been enlarged and heating surface extended that larger amounts of fuel may be burned. In one direction only has the designer found the way blocked against his ingenuity. He has not been able materially to augment the strength of the fireman, and, consequently, the power of the modern locomotive has not increased in proportion to its dimensions. A laborer in working unloading coal from a car merely dropping it over the side, handles about 6,000 lbs. of coal per hour. A locomotive fireman, when some engines are working to the limit, will handle an equal weight of coal, standing on an unsteady platform, placing it on some particular part of the grate and closing the door after each scoopful. Because of the limitations upon the strength of the locomotive fireman, it is probable that the further growth of the locomotive will await the coming of an automatic stoker which will serve to remove the operation of the locomotive from dependence upon the physical endurance of a single man.

Regarding the pull at the drawbar which a locomotive exerts, Professor Goss made a statement which seems to us very extraordinary to say the least of it. The principal remarks under this head read: "The amount that a locomotive will pull at the drawbar depends upon speed. At slow speed the maximum pull is limited by adhesion. After the point in the speed is reached for which the adhesion is sufficient to permit the development of the full power, the pull is inverse-

ly proportioned to the speed. For a locomotive capable of developing 1,200 h.p., the pull at 25 miles an hour is 22,500 lbs., while at 80 miles an hour it is about 7,000 lbs." Taken literally this would imply that three times the power was used up in pulling a train at 25 miles an hour which is necessary to keep the train going at 80 miles an hour, but we assume that the surplus power put upon the drawbar at the lower speed is used up in accelerating the train.

In connection with the difficulties experienced in providing the necessary grate area for powerful locomotives, the question was raised, Are there not other forms of boilers than those common in locomotive service which would better serve the purpose? The merits of various forms of improved boilers such as the Vanderbilt and the Drummond were discussed, but the author found little prospect of the existing type of boiler being displaced. In considering the possible success of a water tube boiler, he said it is well to remember that the present locomotive boiler is not much heavier than the best of the water tube boilers of similar capacity, and the fact that the boiler shell is depended upon to serve as part of the frame of a locomotive, makes it impracticable to abandon the present shell without greatly increasing the weight of the frames.

Draft appliances in connection with the front end of locomotives were discussed at some length and the accepted theory of the action of draft explained. The variety of designs for front ends were alluded to and the conflicting tastes of the designers of draft appliances. The author was not without hope that the problem of the front end will yet be completely solved. It is well known that Professor Goss cherishes the hope of leading to the design of a front end that will be suitable for all classes of locomotives and every condition of fuel and service. When we find religious people come to agree on uniform tenets of faith, we will begin to think that there are prospects of railroad master mechanics agreeing upon the design of a standard front end for a locomotive.

Professor Goss discoursed in a highly interesting fashion on a variety of other subjects, including compound locomotives and other questions which space forbids us from dealing with at present, but full particulars will be given in coming papers.

Steel in Passenger Car Construction.

The use of steel underframes for passenger equipment has been quite general in foreign countries for many years and a large portion of the body of the best foreign passenger cars is made of steel. This passage is taken from Mr. William

Forsyth's paper on the "Use of Steel in Passenger Car Construction," read at the M. C. B. Association's last annual meeting.

In order to show that the subject has not received the serious attention which it deserves, he further says: "The Master Car Builders' Association has never had a committee or a report on steel construction for passenger cars, and, in fact, passenger car framing has not been discussed by the Association since 1885—more than eighteen years ago." Mr. Forsyth prepared his report at the request of Mr. Brazier, who was president of the Association last year.

The steel platform, we are told, became a necessity when full vestibules came to be used, as the wood construction was too light to carry the weight or withstand the blows to which vestibuled car ends were subjected. Steel plates $\frac{3}{8}$ or $\frac{1}{2}$ in. thick were used on the side of longitudinal wooden sills in mail cars, and steel angles and plates have been introduced, but all this is simply a makeshift compared with complete steel underframing, and while it is right and proper to strengthen old equipment in this way, new passenger cars should now be built with entire steel underframes.

The writer calls attention to the somewhat singular fact that the development of the modern coach has been left almost entirely to the car manufacturing companies, and more attention has been given to interior ornamentation than to increased strength in construction. The great number of casualties on the railroads in this country is largely due to the weakness of the equipment which becomes apparent in every collision or bad wreck.

Competition between companies has taken the form of an endeavor to provide attractive interiors, with every sort of comfort-producing makeup and furniture, and as the railroads have allowed the length of cars to increase, and have apparently placed no limits as to weight on the builders, we find now that with cars 70 ft. over sills, and built almost entirely of wood, as a modern sleeping or dining car is built, the section of the wooden sills and of car sides has been increased to assist in supporting the wide space between body bolsters. The builders of cars have no interest in the cost of transporting this extra load, and railroad officers have not carefully considered it.

Mr. Forsyth, while entering a strong plea for the serious consideration of this important subject, does not fail to point out what he believes to be the wrong lines upon which passenger car evolution has been moving. If we may be allowed to put into our own words the idea which we think he desires to convey, we would say that beautiful and luxurious interiors have, in the stress of competition, been the alluring shadow which railroads have

sought to seize, while the substance of safety and lightness in construction has been, in many cases, dropped out of sight and lost.

Heavy parlor and sleeping cars are considered satisfactory in resisting collision shocks, but their strength is obtained by the presence of undue weight, and they are not fireproof. They are also a menace to weaker cars in the train in case of accident. An ordinary passenger train is not symmetrical in strength throughout its length. The problem is, how can the ordinary equipment, in which the larger proportion of passengers are carried and in which, when an accident takes place, the greatest number of casualties occur—how can this ordinary equipment be made as safe as a sleeping car, which in wrecks, rams them like a battleship in collision with a ferry boat.

The increasing number of heavy steel freight cars now used and generally loaded to full capacity, puts the old wooden passenger car at a dangerous disadvantage in wrecks where passenger and freight trains come into collision, or where adjoining tracks are occupied by heavily loaded modern freight cars.

Threatened Break in Pool Price of Steel.

When the poet Burns wrote the words, "The best laid schemes of mice and men gang aft agley," he popularized the expression of a truth acknowledged long before poets' songs or sentiments were put on paper. No personage was ever so mighty, and no individual was ever so humble, whose schemes great and small did not occasionally come to grief and disappointment.

We have fallen into this line of cogitation through indications coming to us that the most stupendous combination of wealth ever organized, the United States Steel Corporation, is having difficulty in suppressing competition, the purpose for which it was formed. The steel trust has steadily maintained steel rails at about ten dollars a ton above the value which would return a reasonable profit, and the scheme was to maintain this unfair price indefinitely; and yet, in spite of the far reaching control that great aggregation of capital gives over competitors, some small rivals have been lately selling steel billets nearly four dollars below the trust price.

The concern that dared to undersell the Steel Trust prices was the Republic Iron & Steel Company, of which John W. Gates is the controlling spirit, himself practically uncontrollable. We once heard a famous steel maker declare that no scheme was safe that could be marred by "that man Gates." Vigorous efforts have been made to bring the Republic Iron & Steel Company to a realizing sense of the dangerous practices they have indulged

in, but it is doubtful that much good has been accomplished. When cutting of prices begins at a time when supply is greatly in excess of demand, the temptations to sin are too great. Railroad people can regard the cutting of steel prices with equanimity, for a general disruption of the agreement to maintain prices might probably result in railroads being able to purchase their rails and other steel appliances at one-third less than the prices exacted by the Steel Trust.

Examinations on the New York Central.

The new system of examinations for promotion in the mechanical department of the Vanderbilt Lines, which is to be put in operation on October first of this year, is looked upon by the men with considerable apprehension. There is always a certain amount of fear connected with any innovation, anything foreign to everyday practice, but it is safe to predict that in the end in this case the men will approve the course of the management.

It is a well established fact that many a young man takes up the profession of railroading without the remotest idea of the responsibilities he assumes, or he is indifferent to possibilities and has only one object in view—the certainty of the pay car every month. In order to weed out this class the Vanderbilt Lines are simply adopting a plan similar to the one already in use for some time on the Chicago & Northwestern, a plan which will guarantee to the intelligent and industrious fireman well deserved promotion over the laggard and careless. To this end the company has established three series of examinations.

When a young man enters the service he is given a book containing the questions to be answered at the end of the first year of his apprenticeship. If he fails in this examination, he is dismissed, since only rudimentary principles are involved in these questions. If he passes, he is handed his second series to be answered at the end of the second year. Every effort will be made to help him and at the end of the second year he is given the questions to be answered in the third and final examination. At the final examination before the board of examiners, should he fall below the required 80 per cent., his more fortunate companions will rank ahead of him in promotion. He is, however, given a second or third trial later and before any other examinations take place.

So confident are the officials that by exerting the proper care in their selections the first year there will be no necessity for a second trial at the final examinations, that they consider such a case only a remote possibility. They earnestly request the men to consult the officials

of the various branches as often as convenient, and the officials are instructed to do their utmost to present all doubtful matters in as clear a form as possible to the applicant.

The reading of good mechanical books and current mechanical periodicals is desired, but it is to be understood that the applicant giving the answers, both oral and written, in his own language will be considered the more competent and receive the higher percentage.

It is always to be borne in mind that by constant, daily observation the practical side is easily acquired, and by combining this with theory, success is assured. One reason why so many young men fail of promotion is that they put off till some indefinite future time the consideration of those things which they ought to have constantly in mind. Some trainmen are talking very strongly against this movement to test the intelligence of their class, and are trying to work up opposition. Our advice is "go slow." Those taking active part against the thing will merely do themselves harm.

There is nothing to fear and much to gain from the examinations proposed by the Vanderbilt Lines and they will certainly enable the brotherhoods to raise their already high standard of proficiency. This movement on the part of the Vanderbilt lines to select the best trained young men available as recruits is likely soon to be inaugurated on all our leading railroads. A system of selection, based on knowledge and intelligence, has been in operation for some time on the Chicago & Alton Railroad, and the officials of the Erie have been considering for several years the propriety of examining their trainmen to test their practical and theoretic knowledge. The movement is one of self defense against the errors resulting from ignorance and indifference. We expect that this line of progress will receive the cordial support of all concerned.

The Work of the Road Foreman of Engines.

"Brick arches are a nuisance where engines are pooled and are wanted by the operating department before they arrive at destination." This was one of the sentences contained in a very thoughtful paper read by Mr. P. H. Stack at a recent meeting of the North-West Railway Club. In cases where the operating department want engines before they arrive, he held that it was much better to run without an arch, and if necessary reduce the nozzle tip to compensate for the loss of the arch. "Clean flues without an arch are much more economical than filled up flues with an arch."

Mr. Stack believes in getting over the road surely as well as economically,

because, he says, a good steaming locomotive is essential to prompt movement of trains and also to economy in supplies. A poor steaming engine will delay several good steamers and lay out trains at meeting points.

To see to all this intelligently he holds that a road foreman of engines should be a good engineer and fireman, one who is competent to handle a train, or fire an engine with the same efficiency as those under him. He should be a teacher and should know all about lubrication, as the oil bill makes a close second to the fuel bill.

One of the qualities required of a good road foreman is the ability to find out the real disease. That is, what medical men would call the art of diagnosis. The road foreman should be competent to find defects which interfere with steam production, be it valve, cylinder, front end, quality of coal or locomotive operation. The man who does this kind of work should not be hampered with office details. His work is on the road and in the roundhouses and not in writing reports. His title is *Road Foreman*.

When it comes to quality of coal the road foreman should, if different qualities are used in his territory, have certain qualities assigned to certain districts and the engines drafted to suit, but if that cannot be done he should draft all engines to suit the poorest quality, and this causes him to have an eye on engines in the back shop, the engine house, on the road and on the clinker pit.

The smoke arch should be air tight, and the door of the front end is an important factor in obtaining this result. A good coat of cement, he advises, should be placed on the bottom of all smoke arches to prevent leaks. A copper wire gasket makes a good door joint. Sheet or ball asbestos also make a good joint but red lead should not be used. Shopmen should be instructed as to how to properly tighten up a smoke box front door.

Mr. Stack points out that in testing steam pipe and nozzle joints for leaks that a water connection at the steam chest is preferable, and if steam pipes are hot, warm water should be used. He says emphatically, Do not test nozzle joints by placing a rubber gasket, board and jack on top of the nozzle, as this may make a tight joint during the test which may be loose on the road. Use a wooden nozzle plug to stop up the nozzle.

The author of the paper makes a timely protest against the bad practice of bushing or bridging nozzles. The best practice, he says, is to make a new bushing for the size of tip required. He also advises that the blower pipe be kept tight and as nearly as possible

in the center of the stack, and the same be done with air pump exhaust. Speaking of the blower he says, when used for fire cleaning it should be opened only enough to keep the gases from coming out of the fire box door, otherwise it may be called, as it is, "the flue leaker," especially when applied full on with a very thin fire in the fire box. If the deflector plate be so adjusted that it will clean the front end he thinks it will do away with the delay of cleaning front ends on the road and he says to the road foreman: "If your superior officers have no objections to self cleaning front ends, advise taking hopper and hand hole plates off." Road foremen should select with great care the engineer to train a student fireman. Pick out, he says, a first class engineer to send a novice out with him if you want results.

Book Reviews.

Boiler Construction. By Frank B. Kleinhans. First Edition. Publishers, The Derry Collard Company, New York, 1904. Price, \$3.00.

The book is what may be called a practical work for practical men. It "fills a long felt want," and there is in this case a world of solid truth in that rather over-worked phrase. There are 420 pages, in size, 7 $\frac{3}{4}$ x5 $\frac{1}{4}$ ins. It is well printed, fully indexed and profusely illustrated, and is good all the way through. The matter which has been compiled represents the most modern practice.

The construction of boilers in general is dealt with, and following this, the locomotive boiler is taken up in the order in which its various parts go through the shop. The book opens with the laying out of work and illustrations of the various sheets are given, together with full description of how one should go about laying out any given sheet. The chapter closes with some general remarks on the art of laying out. Flanging and forging, punching, shearing, plate planing, bending, machinery milling and riveting follow with full illustrations of the various operations involved in each process. All through the best and most rapid methods used by large building concerns and in first class railroad shops are given so that the good, careful practice of to-day is put before the reader.

There is a chapter on Boiler Details in which staybolts, rigid and flexible, are dealt with, also sling stays, crown bars, throat stays, stay rods and stay rod feet. Fire box details follow, steam connections, dash plates for domes, throttle and dry pipe supports, front end dry pipe and T-pipe connections are illustrated and explained. Water space and smoke box details, boiler fittings, etc., come in for discussion and illustration.

A chapter on assembling of parts fol-

lows, in which the important work of caulking, with proper shapes of tools, tube expanding are dealt with in a clear and practical way. "Finishing Parts" tells how the smoke box is fitted to the saddle and of how the lagging is put on and kept in place.

The section on Boiler Shop Machinery is printed on paper specially designed, to show the half tones illustrating the various boiler shop tools to the best advantage. This section contains much new and valuable information on the use and care of these machines. There is a quantity of data regarding list of dies and punches, rate of driving rivets, etc. The book closes with upwards of 31 pages of useful tables.

Taken all together, this is one of the best books of its kind which we have seen. It takes the reader from the laying out of the sheets to the completed boiler.

Spangenberg's Steam and Electrical Engineering. By Messrs. E. Spangenberg, Albert Uhl and E. W. Pratt. Publishers, Geo. A. Zeller, St. Louis, Mo., 1904. Price, \$3.50.

This book of 672 pages is written partly in the question and answer form. It is, we are told in the publisher's preface, really a text book of the St. Louis School of Engineering. The mechanical portion, except that relating to the locomotive, has been written by Professor Spangenberg, formerly superintendent of that institution. Mr. E. W. Pratt, master mechanic on the Chicago & Northwestern, is the author of the locomotive portion, and Mr. Albert Uhl, formerly instructor of practical electric engineering in the St. Louis School of Engineering, is responsible for the electrical portion of the book.

It is intended to be a reference work for engineers, electricians, firemen, linemen, wiremen, steamfitters, owners of steam, electric and refrigerating plants. Briefly, the book treats on stationary and locomotive engineering, electricity, compressed air, mechanical refrigeration, gas and gasoline engines, hydraulic elevators, repair work, etc. The illustrations, which are line cuts, amount to 648; they are clear and are placed close to the reading matter which belongs to them. The field covered is large. The beginner in electricity will find the subject treated in a style to suit his needs. Air compressors of all kinds, pneumatic hammers and drills are illustrated and explained. There is a chapter on gas and gasoline engines, also on hydraulic elevators, and one on repair work which takes up the subject of testing lathe centers, rules for screw cutting, the various forms of lathe tools, tempering receipts, pipe fitting, with tables of pipe dimensions and weights, and rules for ascertaining the horse power of belts. The book closes with a most comprehensive index.

Steel Square Pocket Book. By D. L. Stoddard. Publishers, The Industrial Press, New York, 1904. Price, 50 cents.

The object of this little book, which will easily fit in the pocket, is to tell some of the things which can be done with a square. It is primarily intended for the carpenter, but all others interested in the rapid and easy solution of problems which constantly confront the worker in wood will find the book useful.

For example, the steel square can be used to find the height of any object: Measure 100 ft. along the ground and stand that distance away from the object; when the square is held with the short arm on the level of the eye and with short arm horizontal, the observer has just to note when the line of vision to the top of the object passes the long upright arm of the square. If it passes the 12 in. mark, the lower arm being 12 ins., the object is 100 ft. high, as the base of the large triangle or distance he stands away from the object is 100 ft. If the line of vision cuts the 18 in. mark, the object is, by the law of proportion, 150 ft. high. Many useful kinks as to how to make use of the steel square are to be had in this book. It is well indexed.

The Baldwin Locomotive Works have secured a contract from the Erie Railroad for the repair of some 600 locomotives. Speaking of this Mr. Alba B. Johnson, of the Baldwin Works, recently said: "That railroads should contract for repairs to their engines is in accord with the policy which many of them are now following. In some instances the companies' shops may have more than they can do. Again, the repair shops of a railroad often have not the facilities for repairing promptly and with convenience the largest and most modern type of locomotive. It is not improbable, however, that several of the railroad companies which have lately contracted with large engine works for repairs to their locomotives have taken the step as a matter of business policy. Business conditions have prevented them from sending to the locomotive works which they have been accustomed to patronize the expected orders for fresh motive power, and, under the circumstances, the managements have thought it wise to substitute repair orders rather than that no business should be given out in that direction."

The annual meeting of the Traveling Engineers' Association will be held at Chicago, Ill., commencing Tuesday, September 13. The headquarters of the association will be Lexington Hotel, Michigan Boulevard and Twenty-second street. The convention will be in session from the 13th to the 16th, inclusive.

Questions Answered

(61) E. B., Boston, Mass., writes:

In many of your descriptions you speak of the calculated tractive effort. Is not what you give the real tractive effort, and if so, why call it the calculated effort? —A. We use the word "calculated" in this connection because that is exactly what it is. The tractive effort of the engine is calculated by multiplying the diameter squared of the cylinder in inches by the stroke, in inches, and the product by 85 per cent. of the boiler pressure in pounds, and dividing the whole by the diameter of the driving wheels in inches. We say that is the calculated tractive effort because in that formula we make one assumption, all the other figures taken from the engine can be verified by a man with a two-foot rule. The Master Mechanics' Association decided that 85 per cent. of full boiler pressure was a good average for the mean effective pressure in the cylinders at the start. It may or may not be strictly accurate. Many people think it is too high, but, nevertheless, it is an assumption and it cannot be verified unless indicator diagrams are taken, which is the only really accurate way of finding out the M. E. P. for any particular engine. When as high a figure as 85 per cent. of boiler pressure is used as the equivalent of the M. E. P., it presupposes that the valves are not blowing and that there is not any wire drawing of the steam and no excessive cylinder condensation. The reason that this ratio chosen by the Master Mechanics' Association is fair enough for ordinary purposes of comparison is that an engine when newly out of the shop is supposed to be in good shape and when the ratio is used by everybody in such a calculation, it is as fair for one as the other.

(62) J. R., Walkerville, Ont., writes:

The Pere Marquette have sent over on Buffalo Division a couple of Cooke engines fitted with the Allfree-Hubbell valve gear. It is entirely new to us over here and we come to you for enlightenment. A.—There was an illustrated account of the Allfree cut-off adjuster published in the April, 1901, issue of RAILWAY AND LOCOMOTIVE ENGINEERING, page 79, but we think the best way for you to get information on this subject is to write to Mr. Ira C. Hubbell, 1615 Chemical Building, St. Louis, Mo. He has issued a very complete illustrated catalogue on the subject which explains the gear and its operation, and he will be happy to send a copy to anyone who is interested enough to apply for one.

(63) C. E. D., Detroit, Mich., asks:

(1) If you broke a transmission bar pin, how would you fix up to come in?

A.—Use any ^{1/2} bolt on the engine which can be spared, which will make some kind of a fit. A very good substitute for a transmission bar bolt, and one which as a rule will make a good working fit is a knuckle pin. You can take this out of the front coupler of your engine and slip nuts and washers over it and put insplit key to keep it in its place. If you can't find a suitable bolt you will have to disconnect on the broken side and put the valve on its center.

(2) If a tire broke on a 2-8-0 type compound how could it be fixed to bring it in? A.—You must block up the wheel with the broken tire. Do this by running wheel up on wedge and putting washers or nuts, etc., under cellar. Disconnect the sections of the side rod which belong to this wheel.

(3) How many drops are there in a pint of valve oil? A.—There are about 600 drops in a pint of the Galena Company's valve oil.

(4) What is carbon? A.—Carbon is a non-metallic element found in all organic substances, and in carbonates, also in anthracite and other coals, in charcoal, in lampblack, etc. The other forms under which carbon is found are the diamond and graphite.

(64) A. N. D., Evansville, Ind., writes:

Please explain the difference between "pipe threads" and "hose pipe threads," and give a table for hose pipe threads? A.—If you are referring to air brake hose pipe threads, there is no difference, as all the air brake attachments and fittings will screw on to pipes having standard pipe threads. If you refer to city fire hose threads which fit fire hydrants, we cannot give you a table, as these are not uniform all over the country. Some States fix by law the number of threads for certain sizes of pipe, others do not, and confusion sometimes arises when during a severe fire one city lends its equipment to another city.

(65) P. P. L. writes:

In what way is the price fixed on an engine of a certain total weight. Is a certain percentage deducted for boiler-water, fire and sand, or is a certain percentage per sq. ft. of heating surface and a certain amount for sq. ft. of grate area and sand estimated or figured. A.—It is quite usual to give the light weight of engines. It is not got by taking a percentage. It is simply got by deducting the weight of the water and fire from the loaded engine, no notice is, as a rule, taken of the sand. The actual cost of locomotives, not the selling price, may be from 5 cents per pound upwards, depending on the cost of material, of labor and, of course, on the design. It is quite usual to consider the light weight of the engine when quoting or receiving prices.

Laziness.

An observant person cannot be out of doors much without being forced to the conviction that America is suffering from the vice of laziness. Every community is pestered with a multitude of idlers who waste more energy in trying to live without work than would be necessary to provide them with a decent livelihood. The time has not long passed when idle habits were considered disgraceful, but now they are so common that they no longer excite contempt.

A lazy man is the most hopeless of any member of the human race. You may do something occasionally with a person of other kinds of bad habits, but a lazy man is beyond redemption. There are so many men who have for years been drawing a dollar for every ten cents worth of labor that to-day there is an appalling accumulation of arrears of work that will have to be done by somebody for nothing—that would be only fair—in order to balance the account, and the trouble is to get the men to do it. Nowadays it frequently occurs that the man who earns sugar cake never gets anything more than plain bread and butter, while the man who has only earned plain bread and butter takes the cake.

That is the cause of half the labor strikes to-day. In the blessed golden time that is coming, every man will have to earn every square meal that he eats before he sits down to take the first peck at it, and a wholesome frost will lie in wait for the man who is so great and so important that he can afford to be independent of all industry, except such as may be required in preserving cultivation of habits that a self-respecting orang-outang would turn its back on. In these times the man who never does any work dines at some one else's expense. When a man is idle as a matter of choice, it simply means that some one else is doing his work for him somewhere, and will want to be paid for it sooner or later with compound interest to date.

A press despatch from Louisville, Ky., states that, acting under regulations prepared three months ago, the State Board of Health has completed arrangements for the indictment of each railroad corporation which operates in Kentucky, charging that the health of Kentucky citizens and passengers traveling through Kentucky is continually menaced by the "filthy and unsanitary condition" of the coaches provided for transportation. The movement may reach other methods of transportation, such as ferry boats, steamboats and interurban lines.

The Shelby Steel Tube Company, of which Mr. A. H. Hutchinson is manager of sales, have altered their Chicago address to 860 and 861 The Rookery.

The Pennsylvania's Locomotive Testing Plant at St. Louis.

The outline engraving here shown represents the general arrangement of the locomotive testing plant which forms part of the Pennsylvania Railroad Company's exhibit at the St. Louis Exposition. Our illustration is from the pages of the *Scientific American*.

The engine undergoing a test is placed so that the engine truck wheels are on a pair of rails in the usual way, but the drivers are carried on supporting wheels. These supporting wheels are 72 ins. in diameter for passenger engines and are replaced by similar ones 50 ins. in diameter when a freight engine is to be tested. When the engine is in position it is coupled to a traction dynamometer of the lever type with flexible steel plates instead of the knife edges used in ordinary scales.

The way the resistance is put upon the engine itself is by making it turn its driving wheels with the supporting wheels braked to a greater or less extent. The axles of the supporting wheels are extended out beyond them just as if they had outside bearings, although the bearings are inside like those of the engine itself. On these projecting axle ends brakes are applied.

The brake consists of a cast iron disk keyed to the shaft which turns when the shaft or axle revolves. It is smooth, with a series of oil grooves radiating from the center like the spokes of a wheel. On each side of the cast iron disk are copper plates being held in place parallel to the revolving disk in a stationary housing which has bearings on the hub of the revolving disk. When it is desired to apply the brake,

disk. If the engine attempts to go too fast the valve opens up and slows her down.

A traveling electric overhead crane, 43 ft. span, serves the whole testing plant, and is used for handling coal, or for lifting out and placing the supporting wheels when different types of locomotives are to be tested. The water used in the locomotive boiler under test is weighed in two tanks, which are filled alternately, and it is then run into a third tank from which the injectors deliver it to the boiler.

The instruments used in this exhibition testing plant, which is really a locomotive laboratory, are the dynamometer, steam engine indicators, steam pressure gauges, draft gauges for the smoke box, fire box and ashpan, thermometers for smoke box temperatures, calorimeters for ascertaining the qual-

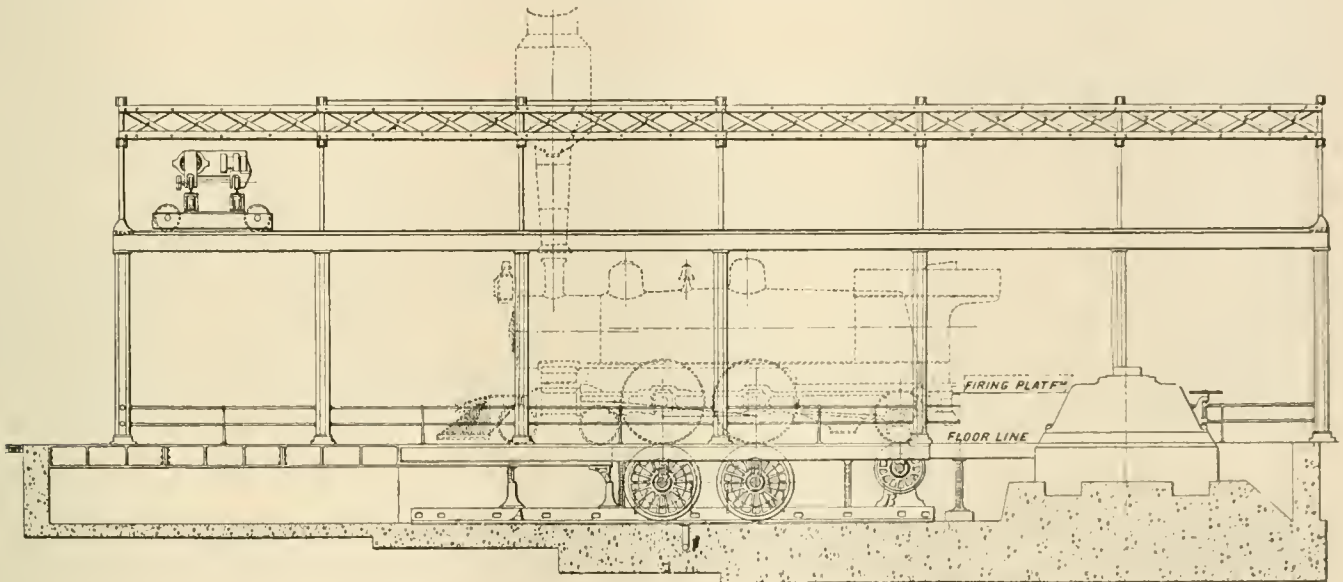

LOCOMOTIVE TESTING PLANT AT THE LOUISIANA PURCHASE EXPOSITION.

The draw bar has a ball joint which allows for any side movement of the engine or any up and down motion of the driving springs.

The dynamometer does not permit the engine to move forward at any time sufficiently to get off the supporting wheels, but the lever carrying the tracing pin has a very long arm and the various resistance springs interposed may be made to show a draw bar pull of 80,000, 40,000 or 16,000 lbs. by an eight inch travel of the recording pen. The draw bar pull is traced on paper 18 ins. wide, which is made to travel at a known rate of speed for each mile run. This record gives the actual tractive effort of the engine, and as indicator diagrams are constantly taken we may expect some very interesting figures at the conclusion of these tests, as to the mean effective pressure in the cylinders and actual draw bar pull.

water under pressure can be made to flow through the chambers in the housing behind the copper plates and press them out against the revolving cast iron disk, and the degree of pressure applied regulates the power of the brake. Oil is introduced on each face of the revolving cast iron disk at the center and the centrifugal force causes it to flow along the radiating grooves and so keep the faces of the disk and the non-revolving copper plates sufficiently lubricated to prevent excessive heat and wear. The circulation of water behind the copper plates not only maintains the pressure required but it helps to keep the friction brake cool. The speed of the engine is maintained practically constant by the operation of an automatic valve on the water supply. If the engine slows down unduly the valve partly closes and reduces the pressure on the copper

plates. A revolution counter and a tachometer for showing the speed in revolutions per minute.

A director of tests is in charge with an assistant, a foreman and a full staff of observers. A total force of about twenty-five men are constantly employed.

Locomotive Frames.

When the committee on locomotive frames reported to the Master Mechanics' Association that they had received 41 replies to their circular asking whether steel or hammered iron was preferred as a material for locomotive frames, and that of these, 18 had favored steel and 15 hammered iron, and that 8 had expressed no preference, it looked as if the hammered iron people and non-committal roads could easily outvote those in favor of steel.

A further analysis revealed the fact

that the 15 roads which favored steel had among them 11,512 locomotives, while those preferring hammered iron had 5,613 engines and the 8 non-committal roads had only 4,015 engines. These figures, when turned into percentages of locomotives, show 55 per cent. in favor of steel, 26 per cent. for hammered iron, and 19 per cent. with no preference. Adding together the percentages of those against steel and those not especially for steel we find that by percentage of locomotives only 45 per cent. could possibly be against steel. The total number of locomotives in this country is given in the report as about 44,000.

The report submits two calculations, one concerning the fiber stresses in the frame and the other deals with water in the cylinders, and the conclusions drawn are given in these words:

"First. The inertia of the boiler following the sudden application of brakes cannot produce a sufficient force to break the frame.

"Second. The inertia of the boiler due to the acceleration of the train by acting with other forces such as those pro-

port to the association at the June convention. A series of thirty-five questions had been sent out to all the roads represented in the M. C. B. Association and various replies had been received. A careful analysis of all the answers was made and on this the committee based its recommendations.

It was found to be impossible to settle on a fair price for work on a basis of piece fitted and applied, because that would have necessitated the separate consideration of every design of steel car and of cars constructed with steel underframes, and then each part or piece would have to be marked and numbered and price fixed for each operation. The committee recommended the much simpler plan of charging 10 cents for all rivets applied, such price to include removing, fitting and replacing the damaged parts; and straightening and repairing at 60 cents per 100 lbs. This is practically like charging for repairs by the foot and seems to be fair and equitable.

The committee recommended that the splicing of steel sills be permissible. The splice, excepting a special case

depreciated value of trucks remain as it is.

In conclusion the committee recommended the appointment of a special committee to consider the price to be charged for steel cars destroyed.

A New Smoker for the Erie.

A smoking and passenger car of unique design has lately been put into service on the Erie Railroad. Through the courtesy of Mr. G. W. Wildin, mechanical superintendent of the road, we are able to show our readers the floor plan of the car, in the illustration.

The striking feature is the smoking compartment, which is placed directly in the center of the car. The walls of this compartment above the window level are composed of plate glass panels 30x54 ins. each, set in hard metal finish. The smoking room, which measures 10 ft. long by about 6 ft. 8 ins. wide, is practically transparent.

The car itself is 70 ft. long over end sills, it has full vestibules and is carried on two standard Erie six-wheel trucks. The interior is finished in mahogany throughout and brussels carpets are used

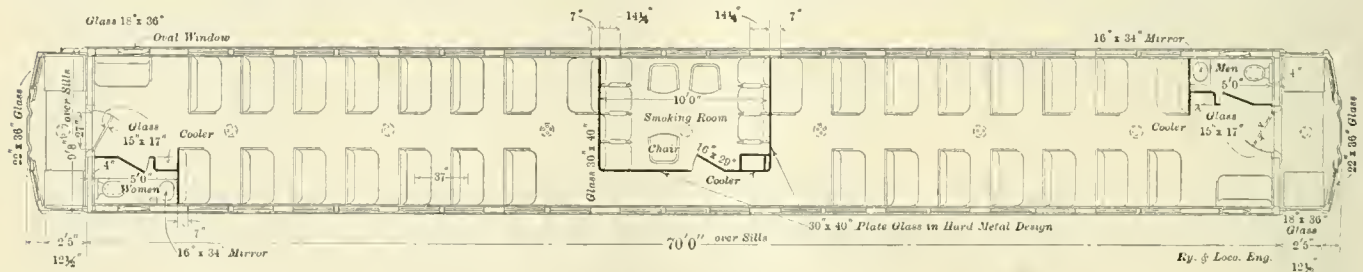

FIRST CLASS COACH WITH CENTRAL SMOKING COMPARTMENT ON THE ERIE RAILROAD.

duced by water in the cylinders, may bring about fracture.

"Third. The dynamic effect of the compression of water in the cylinders is the only force which, unaided, can cause failure of the frames by fatigue."

The report goes on to say: "It may be well to point out that when the right side leads, the right side always pounds harder than the left. This is due to the fact that when the right crank passes the forward dead center the left cylinder is pulling forward so that it aids the right cylinder in throwing the right box against the back jaw of the pedestal. The same is true on passing the back dead center, but when the left crank passes the forward center the right cylinder is pushing on the pin, thus subtracting from the left cylinder in pushing the left box against the back jaw of the pedestal. This should result in breaking more right than left frames when the right side leads and vice versa when the left side leads."

Prices for Repairs to Steel Cars.

The M. C. B. committee on the prices for repairs to steel cars made their re-

ports where center sills are involved, to be placed not less than eight inches from either side of the body bolster, and to be not less than 24 ins. long and to consist of butt joints. The butts to be reinforced by plates on both sides not less than the thickness of the web. The inside plate to include flanges while the outside one should just cover the web, and not less than 18 rivets are to be used.

The charge for replaced parts composed of structural shapes which can be bought in open market should be charged at market prices, and where special construction requires purchase from a manufacturer the charge is recommended to be at manufacturers' prices. A scrap credit of $\frac{3}{4}$ of a cent per pound is recommended.

No steel cars or cars with steel underframes have as yet been put out of service owing to deterioration from age, and the committee suggested that a depreciation of 4 per cent. upon the yearly depreciated value be used for the bodies of steel cars and cars with steel underframes, and that the present 6 per cent. per annum on the yearly

in the aisles, linoleum on the smoking compartment floor and tiles in the toilet rooms. The seats are upholstered in plain plush, Empire color. The smoking room contains two sofas and three wicker chairs, these will accommodate ten persons, while the rest of the car provides seats for sixty-four. A feature of this design of car is that it makes the coach pretty well proof against baggage thieves. The transparent compartment enables a man to enjoy a quiet smoke and at the same time keep an eye on his hand baggage.

A steadily increasing demand for American locomotives in Japan is reported by the secretary of the British Legation at Tokyo. The report states that while the British locomotives have the advantage over the American in solidity of construction and the smaller fuel consumption, the American engines cost less and can be delivered more promptly. The enginemen of the Japanese railroads also express a distinct preference for the American machine as much less troublesome. Repairs are far more easily made.

Air Brake Department.

CONDUCTED BY F. M. NELLIS.

Quick Action and Triple Valves vs. Plain Triples for Tenders.

The relative values of the quick action triple valve and the plain triple

lbs. pressure, while the area of the plain triple valve at 110 lbs. pressure is 15.40 sq. ins., about 50 per cent. betterment for the quick action triple valve.

Higher Braking Power.

One of the principal points of interest brought out at the Buffalo meeting of the Air Brake Association was the fact that at this stage of the air brake art, it is possible to apply, with safety, a higher braking power on passenger equipment cars than has been heretofore the practice of using. The Atsion High Speed Brake Trials, held by the Central Railroad of New Jersey during the months of May and June, 1903, did much to throw additional light on this subject. With steel tired wheels and hard steel brake shoes it was found possible, with weather and rail conditions favorable, to make stops with initial brake cylinder pressure as high as 87 lbs., and terminal pressure at 70 lbs. without sliding wheels. Thus a maximum brake force of about 135 per cent., and a minimum of 105 per cent. at the

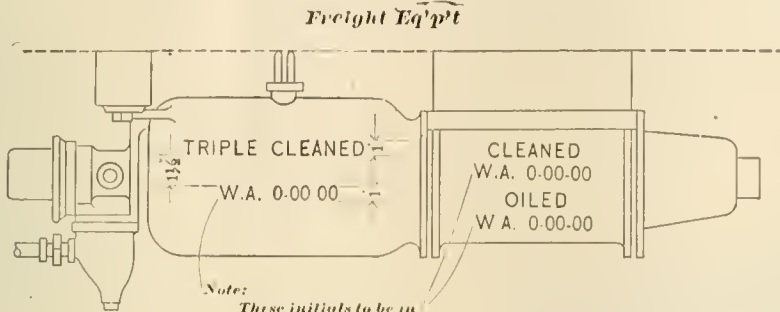

PROPOSED FORM OF STENCILLING.

valve for locomotive tenders comes up for discussion from time to time. Bearing on this subject, some tests were recently made to determine the relative merits of the F-27 and G-24 triple valves for a 10 in. brake cylinder, and the data obtained has been plotted into a series of curves which illustrates this article.

As will be noted the full unbroken lines indicate the pressure at different periods of the quick action triple valve, while the broken lines illustrate the pressures at the different periods of the plain triple valve.

The comparison between the broken and unbroken lines with 110 lbs. train line pressure shows that at the end of 1/4 second the pressure in the brake cylinder with the quick action triple was 38 lbs., while that of the plain triple at the same time was about 3 1/2 lbs. Likewise, at the end of 1/2 second, the pressures were respectively 50 1/2 lbs. with the quick action triple and 11 lbs. with the plain triple. At the end of one second's time the pressures are 64 1/2 lbs. for the quick action and 40 lbs. for the plain triple.

A planimeter measurement of these

Similarly, an analysis of the two lines with the quick action triple valves and

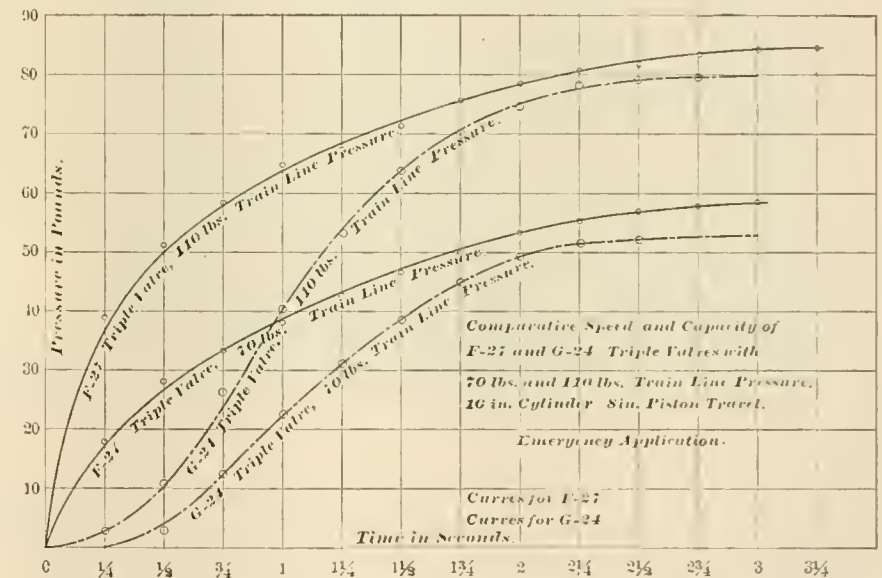

CURVES SHOWING VALUES OF PLAIN AND QUICK ACTION TRIPLES FOR TENDER BRAKES.

plain triple valves at 70 lbs. train line pressure, shows 12.83 sq. ins. for the

end of the stop was made possible without sliding wheels. This is a subject, which, from the discussion at the Convention, would indicate the probability of an excellent opportunity for further investigation. Old rules and old laws cannot hold forever. Modifications and changes are incidents of progress. There is doubtless considerable to be yet learned along the lines of high braking power for modern passenger car equipment.

Passenger Eq'pt

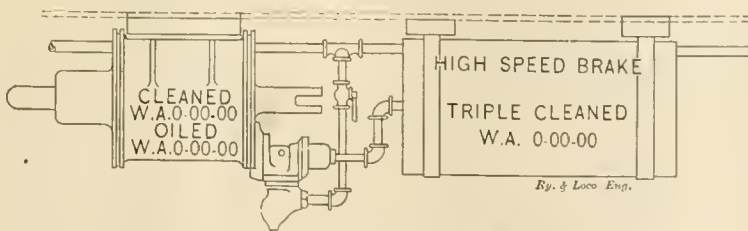

PROPOSED FORM OF STENCILLING.

two lines shows an area of 19.94 sq. ins. for the quick action triple valve at 110

quick action triple and 9.64 for the plain triple valve at 70 lbs.

Eulogy on the High Speed Brake.

An instructive feature of the Buffalo Convention of the Air Brake Associa-

tion, held last May, was that part in which Mr. Brazier, master car builder of the New York Central, in his address to the Convention advised that, with the large number of high speed brakes in service on his road, not a single instance of wheel sliding could be traced

work by asking each member of the association to take a personal part and interest in the selection of this place, ascertaining the most advantageous points with respect to railroad centers, hotel rates, etc., and such other things as will aid the committee in its selec-

tending the convention the selection of place where few of the voters will be able to attend.

Correspondence.

Necessity for a Better Hand Brake on Large Capacity Cars.

The use of large capacity steel cars has made it necessary that a greater percentage of braking power be used in certain districts, or that a higher train pipe pressure be used. While this practice may help out the matter of handling trains by air, it does not, however, help out where cars are controlled by hand in road or in switching service.

A 100,000 lb. capacity car, weighing 40,000 lbs., and braked at 70 per cent. of its light weight, has a braking power of 28,000 lbs. When this car is loaded to 10 per cent. beyond its capacity, the total weight of the car and contents is 150,000 lbs., and the braking power of the car, instead of being 70 per cent., is reduced to 18.7 per cent., an amount that will not permit of a quick stop being made on a grade worthy of being characterized as such. The hand brake power is usually designed to develop the same amount as can be developed with the air brake; hence, the available power is very low with which to stop the car when it is loaded.

Where the light weight of a car approaches 40,000 lbs. it is usually necessary to increase the power end of the

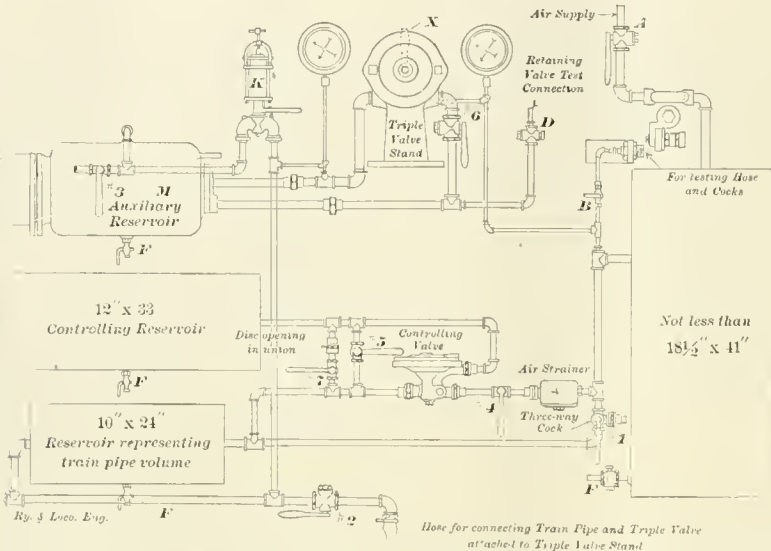

PIPING ARRANGEMENT OF THE NEW WESTINGHOUSE TRIPLE VALVE TESTING MACHINE.

to the door of the High Speed Brake. This was later modified by Mr. Brazier, who said that he was perhaps making a too sweeping assertion on this subject, and that he recollected two or three cases where wheels had been skidded, but that they were equally divided between trains equipped with the high speed brake and with the ordinary 70 lb. brake. As time goes on, increased emphasis is placed on the fact that undue apprehension was formerly had from fear of wheel sliding with such high pressure as is employed by the high speed brake. The automatic reducing feature of the high speed reducing valve seems not only to use the brake cylinder pressure to the best advantage in emergency stops, but to also be valuable as a safeguard against slid flat wheels in functioning as a safety valve. Thus the additional advantageous feature of a safety valve in service stops has been added to the valve which was originally designed to functionate only as an automatic reducing valve in emergency stops.

Meeting Points for Future Air Brake Conventions.

A feature which will undoubtedly prove advantageous and work to better satisfaction is the change made by the Buffalo Convention of the Air Brake Association to place in the hands of the executive committee the selection of the meeting place of future conventions. It is the executive committee's intention to solicit assistance in this

tion of the meeting place. Thus each member, whether attending the convention or not, has an equal voice in the selection of the meeting place. It also requires a person suggesting a place to first find the facilities possessed by that place for holding the meeting and

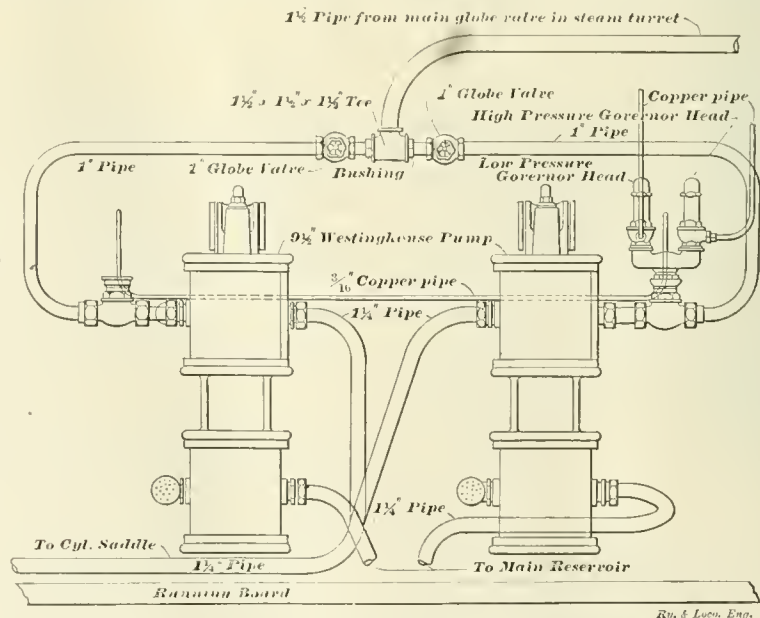

PLAN OF USING TWO PUMPS ON ONE SIDE OF ENGINE AS EMPLOYED BY THE NORTHERN PACIFIC.

makes the nominee of the place responsible for such selection. This will manifestly prove more satisfactory than the old method of voting in the convention assembly for the meeting place, thus placing in the hands of a certain few at-

lever, to introduce another lever, or to introduce a shieve wheel, in order to obtain the requisite hand power. Increasing the power means that it will be necessary to obtain a greater movement of the brake chain in order to pull the

brake shoes up to the wheels. The greater movement of the chain means that it will not only require a greater time to apply the brakes, but that there will be a strong tendency for the chain to foul, either by striking the bottom of the brake standard or by wrapping upon it-

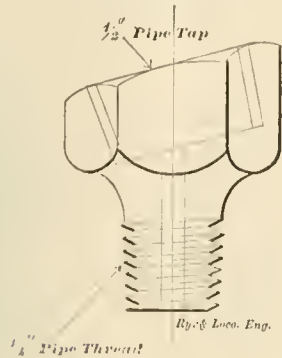

N. Y. A. B. CO. PLUG FOR FITTING OIL CUP TO 8" AND 9 1/2" AIR PUMPS.

self, in either of which cases the braking power will be greatly reduced or entirely destroyed. This defect is somewhat relieved by the use of two brake wheels and staffs, one at either end of the car, one being used to wind up the slack and the other for applying the brake. This practice is not only an additional expense, but it also introduces the evils incident to the use of a hand and air brake, which work "opposite" to each other. Among the objections to such a device is that there is danger to the brakeman if he chances to use the hand brake at the time the air brake is used; the use of the hand brake will render the air brake inoperative as the piston cannot travel by the leakage groove when the air brake is applied, and there is a strong tendency for the brake chain to rupture if the emergency application is used when the hand brake is applied. There are numerous other objections, but these number among the more important.

The accompanying cut illustrates a hand brake gear used on the ore cars

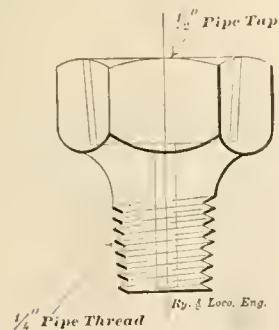

N. Y. A. B. CO. PLUG FOR FITTING OIL CUP TO 11" AND OLD DUPLEX PUMPS.

of the Lake Champlain and Moriah cars. These cars are used on a 235 ft. grade in which there are three switchbacks which permit of no inaccuracies in mak-

ing stops. The light weight of the cars is 29,000 lbs. The carrying capacity of the cars is 100,000 lbs. and they are loaded to 50 per cent. beyond their carrying capacity, and the hand and air brake power is designed to be 130 per cent. of the light weight of the car. The grade and loads are such that foreign cars will not be taken down the grade alone unless some of this company's cars are attached to them.

There is nothing new in the idea of using a gear to increase the hand brake power but the use of this scheme in connection with freight is the first of which the writer is aware.

There is a small gear on the standard connected to the brake shaft, and this works in a gear attached to a staff which is fastened to the end sill. The

To Detect Fall of Pressure and Stoppages in Train Pipes.

I send you herewith illustration of an air brake mechanism which is intended to prevent loss of pressure from any cause, such as angle cocks being accidentally closed, or obstructions forming in the train line after the brakes are once properly working.

Fig. 1 shows the parts used on the engine, and consists of two reducing valves, 2 and 2a, two check valves 3, 3, the regulating valve 4, the cut out cock 5, the connecting rod 6, and the two-way cock 7. The reducing valve 2 is intended to be set at about twenty-five pounds pressure. The reducing valve 2a is to be set at standard signal pressure. The check valves 3, 3, set in piping between the main signal pipe and the bottom chamber

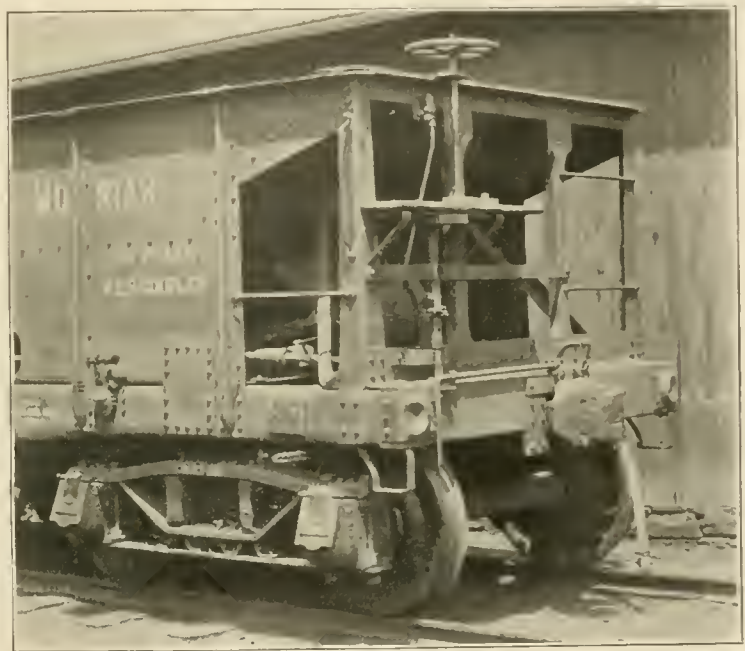

MORE EFFICIENT HAND BRAKE FOR LARGE CAPACITY CARS.

brake chain connects this staff with the push rod of the cylinder so that, in setting the brake, it is only necessary to wind up an amount of chain which corresponds with the piston travel. On account of multiplying the power it is, of course, necessary to make more turns of the brake wheel, but there is absolutely no chance for the chain to foul. A larger and stronger chain can be used, any braking power desired can be used and can be obtained without the use of shieves and extra levers. The cost of applying such a device is about the same as a double hand brake, one at either end of the car and the objections contained in such a gear are eliminated.

A cast-iron plate is inserted just above the gears for a double purpose, viz., to take the strain, rather than have it come upon the foot board, and to protect the gears.

R. H. B.

Pittsburgh, Pa.

of the diaphragm valve in connection with piping and regulating valve 4, is for the purpose of reducing the signal pressure without causing the whistle to blow, and at the same time allow the whistle to respond correctly if a reduction is made from the train in the regular way.

Fig. 2 shows the mechanism on the rear of the last car. It is removed at the end of each trip, and becomes a part of the trainmen's supplies.

Fig. 3 shows detail of check valves 3, 3. When a reduction is made in signal line by regulating valve 4, air is drawn equally from signal line and bottom chamber of diaphragm valve, until pressure is reduced down to what reducing valve 2 is set for. The regulating valve 4 then closes, and signal system is supplied by reducing valve 2. The two way cock 7 allows air to pass through piping when closed and allows air to pass to at-

atmosphere when open, and is for the purpose of emptying the signal line by hand when desired.

Fig. 4 shows detail of regulating valve 4. This valve is attached to top of brake

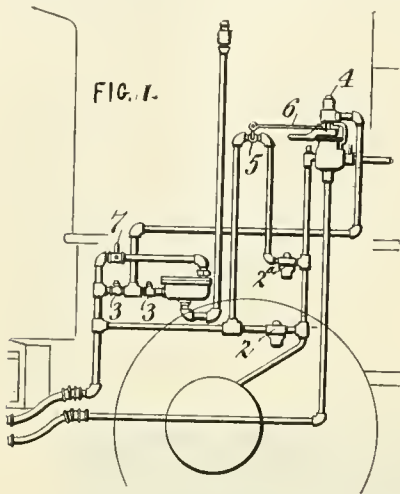

valve and is connected by stem 8 to stem of brake valve and rotates with brake valve stem. The rotary valve 9 is operated by stem 8 and allows signal air to pass through port 10 to retaining valve 11 when brake valve is "On Lap" and in "Service Braking" position. In "Emergency" position, signal air passes through port 12 to atmosphere and empties signal line. In "Full release" and "running position," rotary valve 9 is blank, retaining valve 11 holds corresponding pressure with reducing valve 2 or slightly below. The connecting rod 6 connects brake valve handle with cut out cock 5. This rod is slotted where it connects to pin on brake valve handle, to allow cut out cock 5 to stay "cut out" when brake valve handle is returned to "Lap" when braking. The cut out cock 5 is cut out "On Lap," "Service," and "Emergency" positions, but is cut in in "full release" and "Running position" of brake valve.

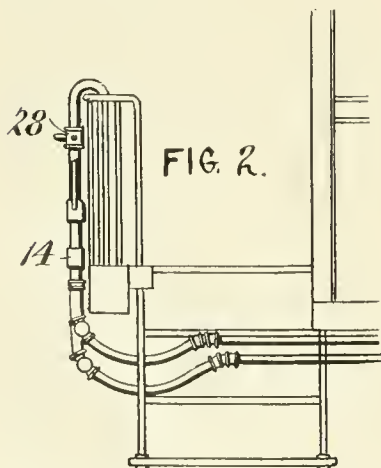
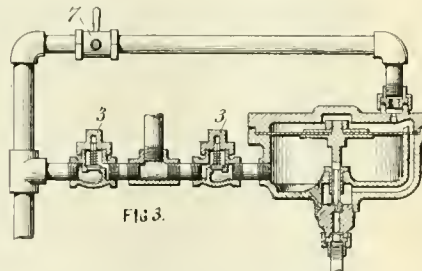

Fig. 5 shows detail of mechanism coupled to brake and signal pipes and suspended on rear of last car of train. The piping 13, 13, is connected to brake line

and piping 14, 14, is connected to signal line. Piston 15, which is exposed to signal pressure, is to be sufficiently larger than piston 16, which is exposed to brake pressure, to cause pistons 15 and 16 and slide valve 17 to move and open port 19 and allow brake pressure to escape to atmosphere, to whatever pressure it is desired to have signal pressure overcome brake pressure and set the brakes, when pressure is being lost.

Port 20 is to allow any air that might leak past pistons 15 and 16 escape to atmosphere. Should air pump stop working, or not be working strong enough to supply brake line with standard brake pressure, and the engineer not notice it, as soon as brake pressure gets down to whatever pressure that piston 15 is designed by standard signal pressure to overcome piston 16 and brake pressure, pistons 15 and 16 and slide valve 17 will be moved, and port 19 will be opened and brake pressure will escape to the atmosphere and set the brakes, thereby stopping the train before brake pressure gets below an effective point.

Service or emergency application of brakes may be had according to size of port 19. When brakes are applied by the action of the valve described, in order



to be released, signal pipe must be emptied either by putting brake valve in "Emergency" position, or by opening two way cock 7. Spring 27 will then move pistons 15 and 16 and slide valve 17 to their normal position, and port 19 will be closed. The brakes can then be released in the usual way and signal pressure restored.

Piston 21, which is exposed to signal pressure, is connected with piston 22 and slide valve 23 by the same stem. Piston 22 is exposed to brake pressure. The port 24 allows any air that might leak past pistons 21 and 22 escape to the atmosphere. Piston 21 is to be sufficiently large to prevent any movement of slide valve 23 when signal pressure is reduced while braking. Sufficient pressure must be retained in signal pipe to prevent operation of this valve. Should any obstruction form in brake line or should any of the angle cocks become closed so that brakes could not be set behind such obstruction in the usual way, by moving brake valve handle to "Emergency" position, signal line will be emptied by regulating valve 4, and piston 22 will then move piston 21 and slide valve 23 and open port 26, allowing brake pressure to

escape to atmosphere and set brakes behind such obstructions or angle cock. The idea in reducing signal pressure while braking, is to prevent operation of pistons 15 and 16 and slide valve 17, when reasonably large reductions of train line is made. With the high speed equipment all that is needed in cab is any suitable means for emptying signal line. The

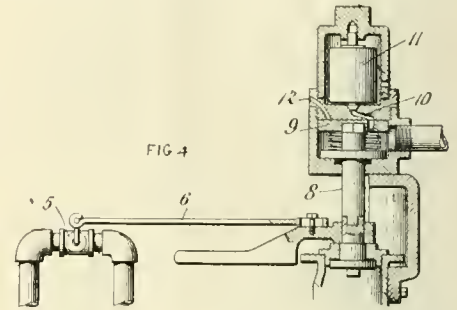

preventative feature consists in setting the brakes before pressure gets too low to be of use in stopping the train. This appliance will compel engineers to watch their pressure or stop the train before pressure is lost, and also afford means of setting brakes behind any obstructions that may form in train line.

The mechanism can be used with any air brake system that reduces train line pressure to set brakes, and restores train line pressure to release brakes, and without destroying the regular operation of brake or signal system.

THOS. J. QUIRK,
Engineer, Michigan Central Railroad,
Buffalo, N. Y.

QUESTIONS AND ANSWERS ON THE AIR BRAKE.

(65) L. W., Xenia, O., asks:

What is the advantage of emptying the equalizing reservoir in emergency

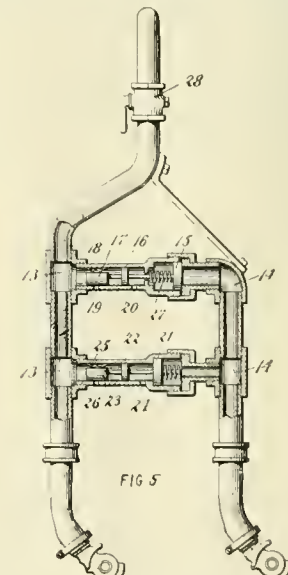

position of the D-5 or F-6 valve? A.— There is really no advantage in emptying the equalizing reservoir of the D-5 or F-6 brake valve in emergency appli-

cations. The only advantage which might be claimed for it is that it permits the black hand to drop, thus showing clearly that train pipe pressure has been reduced when the engineer makes the emergency application, and thus satisfies him.

(66) R. L. E., Grand Rapids, Mich., asks:

What harm would be done to a brake valve if the train pipe exhaust elbow was missing? A.—The outlet for train line pressure would be somewhat increased, as the exhaust elbow restricts the flow of train line pressure to the atmosphere. No real harm would be done, except to slightly increase the tendency toward undesired quick action with light engine or very short train. Many valves are now running which have the exhaust elbow missing.

(67) L. R. J., Piqua, O., writes:

What would be the result if the drip pipe connection, 35, of the air pump governor is plugged? A.—The air pressure leaking past the piston from the top side and mingling with the steam pressure leaking up from the bottom part of the governor to the under side of the piston, would combine with the upward pressure of the spring, 31, and prevent the piston from descending and closing the steam valve, thus failing to shut off the steam supply to the air pump.

(68) A. B., Armona, Cal., asks:

What is meant by releasing through a diaphragm? (Question 42, May issue). A.—A diaphragm is used in which there is a small hole to restrict and regulate the flow of air to any portion of the brake system. Where this restriction is desired such as making tests with triple valves, it is equivalent to almost closing a stop cock in the pipe, with the exception that a regular stated and desired flow of air will be had through a certain size hole in a diaphragm, which could not be obtained with a partially closed cut out cock.

(69) J. J. T., Philadelphia, Pa., writes:

In using the engineers brake valve in service application, the brake works O. K. on engine and tender, but when I use it in emergency there is a blow of air from the exhaust of the triple valve for a few seconds while I am in emergency, and the brake sets O. K. When I go to release I get the release of air from exhaust again, but a little stronger. It is a plain triple and brake valve has slide valve feed valve attachment. What is the matter with this? A.—There is probably a lump on the slide valve seat, directly under the cavity of the slide valve, when the valve is in release position or in service position. When the triple goes to emergency position, the

slide valve mounts the lump and causes a bad blow of air under the face of the slide valve and out at the exhaust port. This seems probable from your description of the trouble.

(70) G. B. C., New York City, writes:

Why is it that after the automatic brake has been fully set, and no more brake power can be had, that the straight air brake can then be set on top of it, and set stronger each time you apply it, so that it will be felt in holding back the engine? A.—Perhaps the brake cylinder packing in either the driver brake or the tender brake is in a leaking condition. After the automatic brake is set full it can be set no tighter. If the cylinder packing leaks, however, and the straight air brake be now applied, main reservoir air can be put into the cylinder to the limit of the capacity of the reducing valve, which is about 50 lbs. In other words, the brake cylinder leakage, which gradually reduced the braking power, can be kept up with straight air brake, as the cylinders are directly connected with the air pump; but when the automatic air with the auxiliary reservoir pressure has been equalized into the brake cylinder no further increase in pressure can be had.

(71) C. L. E., Reading, Pa., writes:

I noticed on a new engine from the Baldan Works, going through here the other day that two reservoirs were on the engine. The air was pumped into the end of the first reservoir. There was a coupling pipe connecting the two reservoirs, the pipe leaving the first reservoir left at a point directly opposite to where the air was discharged by the pump into the first reservoir. The coupling pipe led into the second reservoir at a point directly opposite to where the air was taken from the second reservoir to the engineers brake valve. Is not this pipe arrangement of a bad design? A.—It would be better if the delivered pipe threw air into the reserve at right angles to the pipe which takes it out. This would cause a better circulation or churning up at air in the main reservoirs and would not allow air to pass heated from the pump through the two reserves to the brake valve.

(72) C. L. E., Reading, Pa., writes:

I noticed on two Norfolk & Western engines going through here from the Baldan Works, that the driver brake was equipped with a pressure retaining valve, such as is used on freight cars. Please say if it is still considered a good practice to equip driving brakes with a retaining valve. This retaining valve is near the engineer so that he can hold his brake on his drivers by turning up the handle, while the rest of the train is recharging, or he can turn down the handle and let the driver brakes release

along with the train brakes. A.—Retaining valves on driver brakes were considered a good thing at one time, but in the past few years the practice has been generally abandoned, for the reason that the brake cylinder packing leaks, and the brake will release through the leather packing in spite of the retaining valve handle being turned up. This practice of retaining valves on driver brakes has been abandoned since the introduction of the combined automatic and straight air for engines.

(73) B. J. McL., Albany, N. Y., asks:

Will not a hot box on a car journal have anything to do with the sliding of that pair of wheels? Also would it have as much effect when the box is hot as after it is cooled down? A.—Journal will naturally heat if it is insufficiently lubricated or lacks lubrication entirely. When lubrication is absent, or is supplied in insufficient quantities, there is considerable friction between the journal and the brass. This, of course, will cause the wheel to roll with a certain resistance due to journal friction. If the journal is well lubricated, the friction is largely reduced, and the wheel will roll with more ease. Therefore, as journal friction gives a retarding force to the rotation of the wheel, it will naturally follow that anything contributing to retard the rolling of the wheel, gives practically the same effect as if the retarding force were brought to the wheel through the medium of the brake shoe. If a car is braked up to its limit and on the verge of wheel sliding, the additional retardation given to the rotation of the wheel, if it be a frozen shoe, or hot journal, will certainly slide that pair of wheels.

Faulty Metal Brake Beams.

An important feature brought out at the last Air Brake Convention was that of brake beams of too great length. In the discussion of this subject it transpired that many brake beams were now being applied to cars which, upon being subjected to pressure, would lose their camber and straighten out, thus increasing their length. This permits the brake shoes to overlap the wheels and brake shoes to wear unevenly, producing a flange on one shoe and possibly crowding the other shoe tightly against the throat of the flange on the opposite wheel. Frequently, in order to use up brake shoes thus worn, railroads will exchange the shoes from one end of the beam to the other, thus having the shoe worn to a flange bearing only on the narrow area of the flange projection. This robs the shoe of considerable braking power to the disadvantage of the brake on that car. However, an improvement may be expected as this has been taken up by the M. C. B. Association.

Section of Pennsylvania Railroad Tunnel.

We give here a view of a section of the Pennsylvania Railroad tunnel to be driven under the Hudson river. The cast iron section is a real one and will eventually be used in the tunnel itself, but at present it is one of the railroad exhibits at the St. Louis Exposition. Our illustration is from the *Scientific American*.

The section is composed of eight complete rings, each 2 ft. 6 ins. wide, thus making the exhibition tunnel 20 ft. long. The whole interior of the tunnel is lined with concrete and along

heavy cast iron screw pile driven through an opening in the floor, and this pile will be screwed down through mud and silt until it reaches either solid rock or takes a bearing capable of sustaining the required load. The piles will pass through the tunnel floor with a sliding fit, and upon the tops of the piles will be a system of heavy transverse girders with longitudinal stringers which carry the track rails.

This form of construction leaves the tunnel floor free from what civil engineers call the rolling load. It is practically bridge construction in which the piles are the bridge piers

ment at places which would eventually result in leakage and fracture. Of the 24,049 feet of cast iron single track tunnel to be built, 12,174 ft. will be supported upon screw piles.

Brotherhood Meeting in Montreal.

Nothing is so conducive to good results to the railroads and the public as the union meetings held from time to time by the Brotherhood of Locomotive Engineers on the various railroad systems of America. These afford the public, which is always prone to believe that all labor unions are antagonistic to capital, an opportunity to compare that view with the views of the railroad official and his engineers.

The growing popularity of these meetings was demonstrated at the union meeting in Montreal in August, which was attended by over five hundred members from all parts of the British Provinces and adjacent parts of the United States.

That the railroads appreciate the importance of these meetings was shown by their willingness to furnish transportation to all members and their families who wished to attend the gathering.

The first day's morning and afternoon session—from which the public was excluded—was entirely devoted to an exchange of views on the best methods of handling power, obligations to the railroads and the public, and the question of how to increase the membership of the Brotherhood without jeopardizing the present high standard and sacrificing quality for numerical strength. The evening session, entirely public, was largely attended by representative men in public life and in the railroad world. Those who came out of idle curiosity and helped to fill the Academy of Music to overflowing, departed firmly convinced that not only had the

Brotherhood elevated the social standing and morals of the engineman, made him a better citizen, protected his family from want and increased the comforts of all their lives, but also had made it possible for the public to travel in safety anywhere on the American continent.

Notable among the speakers were His Worship, the acting mayor of Montreal; the Hon. H. R. Emmerson, Minister of Railways in the Dominion Government; Mr. Jas. Osborne, the general superintendent of the eastern division of the Canadian Pacific Railway; Rev. William O'Meara, D.D., of Montreal;

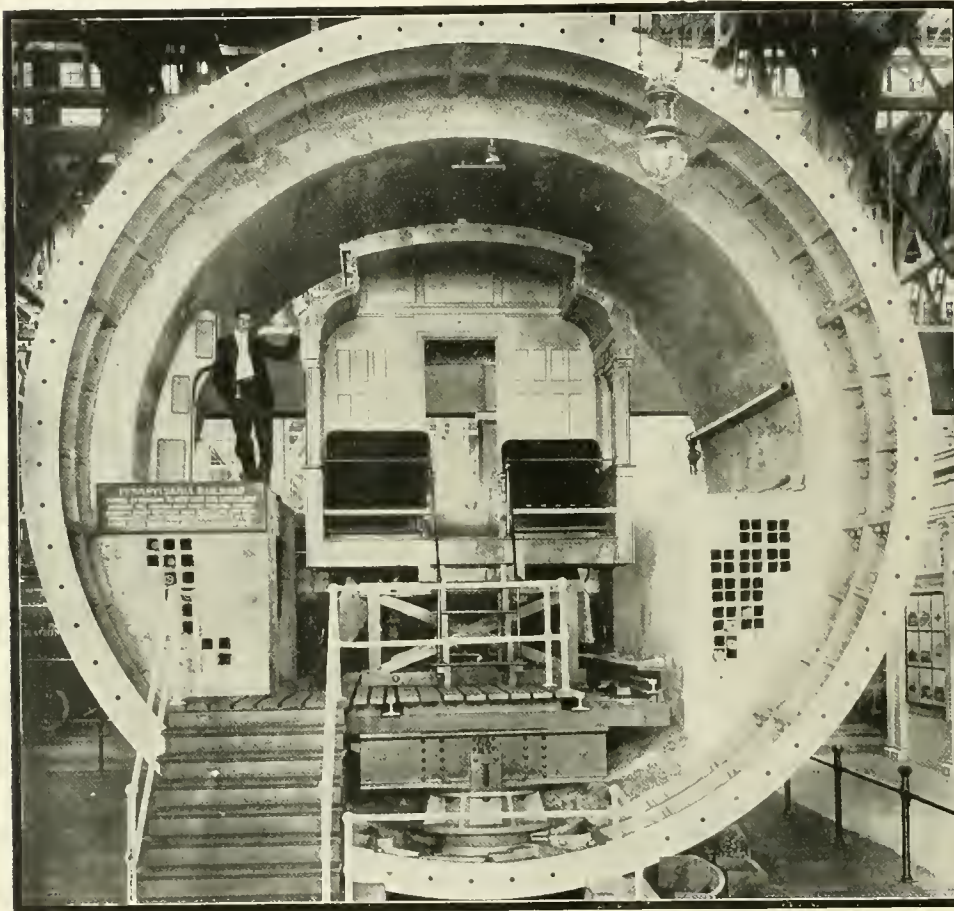

SECTION OF THE PENNSYLVANIA HUDSON RIVER TUNNEL, AT THE ST. LOUIS EXPOSITION, WITH SECTION OF COACH INSIDE.

each side there is a mass of concrete carried up to about the level of the car windows. The mass of concrete is penetrated by a number of conduits for electric wires, etc. The top of the concrete mass is made flat so as to provide foot paths by which passengers can walk safely along, and so get out of the tunnel in the event of failure of current or break down of the train itself.

An interesting feature of the tunnel is the way the weight of a moving train will be sustained. The tunnel tube is to lie in the mud and silt of the river, and at every 15 feet there will be a

and the rails and ties lie on steel girders which do not touch the tunnel floor while the cast iron tunnel shell simply surrounds the moving train as a circular envelope capable of resisting the pressure of the outside mass of wet mud and silt.

The object of placing the tunnel at such a level as to necessitate the use of piles and girders is to avoid heavy grades at the shore ends. The silt and mud are quite solid enough to hold the tube imbedded in it in perfect alignment, but it was considered that heavy Pullman trains if supported by the shell alone might cause some slight settle-

Rev. J. B. Silcox, of Lansing, Mich.; Grand Chief W. S. Stone; First Grand Engineer W. B. Prenter, and last, but far from least, that Irish wit and humorist, Patrick Fennell, better known to the Brotherhood as Shandy Maguire.

The second day was devoted to sight-seeing and inspection of the Angus shops of the C. P. R., at Hochelaga, the largest and most complete in Canada. The C. P. Railway tendered a special train of twelve cars for the occasion. The third day was given over to a morning trip, tendered by the city of Montreal, over the Grand Trunk, to Lachine and down the St. Lawrence river through the Lachine Rapids, where the river makes a drop of over twenty feet. In the afternoon a special train from the Grand Trunk was furnished the delegates by the company to convey them over the Jubilee Bridge spanning the St. Lawrence river. This wonderful struc-

A Pacific Type Engine for the Michigan Central.

The Michigan Central Railroad, of which Mr. E. D. Brouner is superintendent of motive power and equipment, has lately received from the Schenectady shops of the American Locomo-

holes in which they are a close fit. The holes for these bolts in the binder itself are each oblong like the oblong expansion holes in a rail end. It is, therefore, apparent that the bolts cannot do more than prevent the binders from falling, or being pulled down.

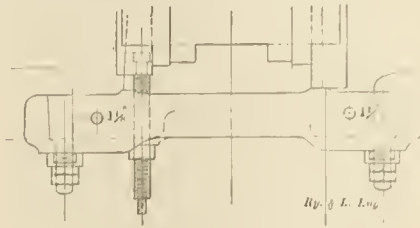

M. C. R. R. PEDESTAL BINDER.

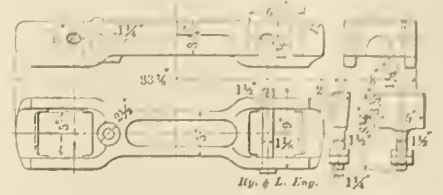

DETAILS OF M. C. R. R. PEDESTAL BINDER.

tive Works some fine 4-6-2 engines which have been put to work on the heavy passenger traffic which passes over the Canadian Southern Division of that road. This division is singularly

The pedestal binder is made of cast steel with and fits up snugly on the inside surfaces of the lower projections of the jaws. The binder at each end surrounds the jaw ends and a broad

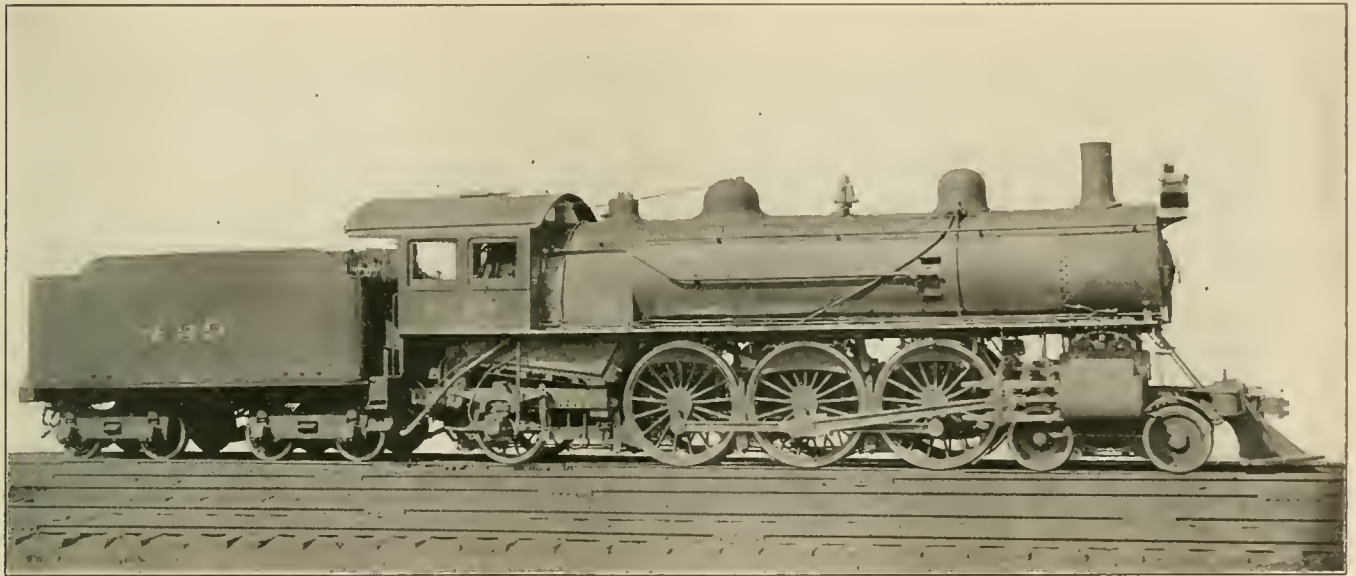

PACIFIC TYPE ENGINE FOR THE MICHIGAN CENTRAL RAILROAD.

E. D. Brouner, S. M. P. and Equip't.

American Loco. Co., Builders.

ture is a mile and three-quarters in length, and replaces the once famous Victoria tubular bridge. In the evening the C. P. placed a special at the disposal of those who wished to visit the historic city of Quebec.

To the untiring efforts of Chairman Thos. Clark and his committee the success of the meeting is largely due, and it is to be hoped that at the next union meeting in Riviere du Loup, a year hence, the pleasant relations already existing between the Canadian railroads and their employees will be more firmly cemented than ever, and we know that a cordial welcome from all Canada awaits the Brotherhood delegates from among "our American cousins." **JOS. A. BAKER.**

The life of the locomotive is becoming shorter because of the heavier work which it is required to do.

free from curves and grades and the engines have given a good account of themselves.

The engines are simple, with 22x26 in. cylinders, and carry about 140,500 lbs. on the driving wheels and these are 75 ins. in diameter. The maximum calculated tractive effort or starting power of these engines is about 28,500 lbs. and the ratio of tractive effort to adhesive weight is as 1 is to 4.88. The valves are of the piston type, actuated by direct motion. They are outside admission and have a full travel of 6 ins.

An interesting feature of these engines is the novel type of driving pedestal binder which is used, and which is shown in our line illustration. There are no vertical frame bolts used in the binder. It is held in place by two 1 1/2 in. horizontal bolts which pass through the lower ends of the pedestals, through

wedge-headed bolt is dropped in at each end. The nuts on the bottom are then tightened up and the jaws are held firmly against that part of the binder which is really a spacing piece between the jaws. The horizontal bolts referred to above hold the binder in a level position while the oblong holes permit adjustment by the wide flat headed end bolts.

What is usually called the frame front is in this instance part of the main frame, there being no splice between the forward jaw and the cylinder. In fact, the main frame is solid from the rear of the back jaw to the buffer beam. A slab frame securely bolted to the main frame at the back provides for the rear carrying wheels which have outside bearings though the truck is radial.

The crosshead is of the two guide bar type and the wrist pin is secured

with the nut lock invented by Mr. D. R. MacBean, which was described in detail in the August issue of RAILWAY AND LOCOMOTIVE ENGINEERING, page 354.

The boiler is of the straight top variety radial stayed and is $72\frac{1}{8}$ ins. outside diameter at the first course. There are 354 tubes, 20 ft. long, and these give a heating surface of 3,690.6 sq. ft. The fire box gives 180.3 sq. ft., the water tubes supporting a brick arch give 23.6 sq. ft., making a total of 3,894.5 sq. ft., of heating surface. The grate area is 50.23 sq. ft. A few of the principal dimensions are as follows:

General Dimensions.—Weight in working order, 221,000 lbs.; weight on drivers, 140,500 lbs.; weight engine and tender in working order, 343,600 lbs.; wheel base, driving, 13 ft. 0 in.; wheel base, total, 33 ft. $7\frac{1}{2}$ ins.; wheel base, total, engine and tender, 60 ft. 5 ins.; driving box material, cast steel; diam. and length of driving journals, $9\frac{1}{2}$ ins. dia. x 12 ins.

Boiler.—Thickness of plates in barrel and outside of fire box, $\frac{3}{8}$, $\frac{3}{4}$, $\frac{3}{8}$, $\frac{1}{8}$ in.; fire box, length, $96\frac{1}{2}$ ins.; fire box, width, $75\frac{1}{4}$ ins.; depth, front, $79\frac{1}{4}$ ins. back, $64\frac{3}{4}$ ins.; fire box plates, thickness, sides, $\frac{3}{8}$ in.; back, $\frac{3}{8}$ in.;

make an extremely thin but highly sensitive surface on the back of each sheet.

There is not any ordinary form or blank, used in railway service in which duplicate or manifold record is required, which cannot be manufactured by this company. One of the most notable time savers which they are regularly producing in large quantities for railroad use is the well known M. C. B. defect card. This form or card blank is put up in books containing fifty triplicate records and not only supersedes but entirely eclipses the old form of defect card with stub and counterfoil. The clerical work necessary to fill out a "manifold" defect card required in car interchange is from one-half to one-third the old method and the chance of error is almost entirely eliminated. The record made by a pencil conveyed through the Manifold Company's carbon sheet to the actual card which is tacked to the needlebeam of a freight car, is held to be equal to indelible pencil, which is required by the M. C. B. code of interchange rules. If the

eral users of the Manifold Company's method. At the present time they have a form of enginemen's trip ticket which contains the necessary information concerning the run, also the overtime claim, the amount of oil taken and the coal received. All this is contained on one carbon backed sheet which when written and signed can be torn out and forwarded to the auditor of statistics, leaving a facsimile record in the book which is entirely free from the least chance of error owing to transcription. In the matter of requisitions on the storekeeper the Manifold Company provides a blank which reduces the clerical labor one-half and at the same time gives a facsimile record so that the requisition cannot be altered without the addition or subtraction of any item instantly apparent when original and carbon copy are compared.

In the matter of train orders the Manifold Company supply a blank which when written upon with a good pencil in clear handwriting will give as many as nine perfectly legible copies. When the sys-

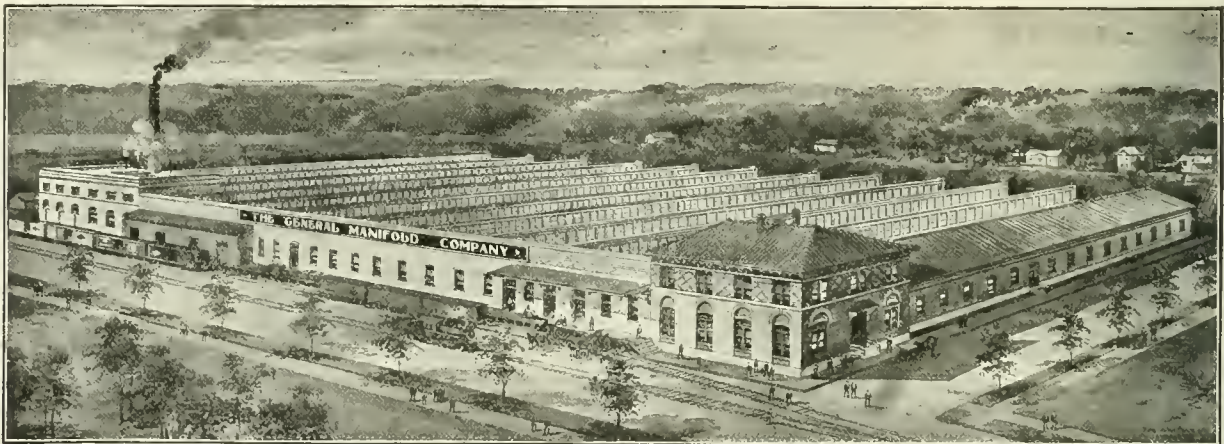

MAIN OFFICE AND WORKS OF THE GENERAL MANIFOLD CO., FRANKLIN, PA.

crow, $\frac{3}{8}$ in.; tube sheet, $\frac{1}{2}$ in.; fire box, water space, $4\frac{1}{2}$ ins. front, $4\frac{1}{2}$ ins. sides, $4\frac{1}{2}$ ins. back. Tender—Style, water bottom; weight, empty, 52,600 lbs.; wheel base, 18 ft. 0 in.; tender frame, 10 in. channels, $\frac{1}{4}$ in. web; water capacity, 6,000 U. S. gallons; coal capacity, 10 tons.

The General Manifold Company.

The General Manifold Company, of Franklin, Pa., is a corporation whose business it is to manufacture a clean manifolding preparation and of applying it to paper in such a way that facsimile records may be kept on file while the original may be forwarded through the mails or otherwise. The fundamental idea in their manifolding process is to make a carbon back to a sheet of paper which will be dry, clean, waterproof and what the manufacturers call "non-crocking," which means that the dye will not come off. The carbon used is made by secret process under patents owned by the company, and is applied to the paper by special machinery in such a way as to

Manifold Company had done nothing else to reduce the clerical labor of a responsible and busy man at interchange points than by the introduction of the manifold M. C. B. defect card, that company would have a right to say that it had fully justified its existence. There is no more tedious and troublesome work than that of making out defect cards, filling them in on both sides, entering the items on a contracted stub and re-duplicating the items upon a counterfoil. The amount of correspondence and searching for evidence as to what is the real intention of the card with all the inaccuracies of this old four-fold record system is entirely eliminated by the use of the General Manifold Company's defect card. There is no cramping of details, the record is as long and wide as the card itself and the chances of going wrong in transcribing are constantly reduced to a minimum.

The Canadian Pacific Railway are lib-

tem of typewriting all train orders becomes general, which in all probability it will in the future, the value of the manifold facsimile record will be undisputed. In fact one of the strongest points about the whole system of manifolding is the fact that it gives an absolute reproduction of the original, and in matters of importance such as train orders, the absolute fidelity of the copy cannot be estimated too highly.

The plant of the General Manifold Company is one of the largest in the country and is the very largest devoted to the manufacture of carbon paper and manifold books, the area of the building being 150x407 ft., one story high and of saw-tooth roof construction. The company employ about about 150 hands and the factory has a capacity of approximately \$500,000 worth of business annually. They are now introducing and placing on the market a new line of typewriter carbon paper, equal if not superior

to anything now being used, and the probabilities are that an immense business will be developed along this line, this carbon paper is being well received wherever introduced.

General Charles Miller is president of the company and Mr. R. S. Radcliffe is general manager. There are General Manifold offices in New York, Boston, Philadelphia, Chicago, Denver and San Francisco, but the main office and works are situated at Franklin, Pa.

Accident Bulletin No. 11.

The Interstate Commerce Commission have issued Accident Bulletin No. 11, which gives the records for January, February and March of this year. The total number of persons killed was 221, and injured was 2,797. There were in all 1,659 collisions and 1,140 derailments, and the total loss to railroad companies through these two classes of accidents amounted to \$2,256,477.

A very instructive table containing details of twenty-six prominent train accidents are given, and out of the 26, there were 20 collisions and 6 derailments. And among the 20 collisions 15 were butting, 3 were rear and 2 miscellaneous. A still closer analysis shows that of the 15 butting collisions, 2 were caused by the failure of the dispatcher, 4 by engineers, 1 by signalman, 1 by a conductor, 3 by operators and 2 by brakemen. Another was caused by the failure of engineer, conductor and operator, and still another by the failure of engineer and conductor. In the 15 butting collisions there were 2 dispatchers, 6 engineers, 1 signalman, 3 conductors, 4 operators and 2 brakemen involved. The most serious accident of all, specially referred to in the report, was the last one named, in which an engineer and a conductor failed to identify a freight train in a siding and assumed that the one they saw was the one they had orders to meet and pass. Eighteen passengers were killed and thirty-seven were injured in this disaster.

Even a casual perusal of the Interstate Commerce Commission's report cannot fail to bring home to the reader the fact that there is an enormous load of responsibility resting upon the shoulders of the men on the locomotive. The great majority of these are "good men and true," who are fully alive to the serious side of railway operation, and we believe that they are more earnestly anxious to "play the game" according to the rules than to take chances.

The fair and impartial examination of the causes of failure and the dispassionate recording of the truth must tend to deepen the feeling of moral responsibility in railroad operation, which every railroad man, worthy of the name, has in some degree. It is nevertheless true that if ever we are truth-

fully to be able to say that American railroad operation is not only the cheapest but the safest in the world, every single man engaged in railroad work must keep that end steadily in view all the time and must never let "I think so" take the place of "I know."

Piston Valve Guide.

The accompanying sketch shows a piston valve guide which was got up at the Santa Fe shops at San Bernardino, Cal., and is now being used in these shops for the purpose of guiding, or entering, piston valves in Vauclain engines. This is made very cheaply, consisting as it does of cast iron, and is made to suit the different classes of engines which we have on the system, the guide for each class of engines being stamped and kept in the tool room, under check.

It will be noted that three stud holes are applied, and the small shoulder on the back holds the guide central, the taper closes in the packing rings as the

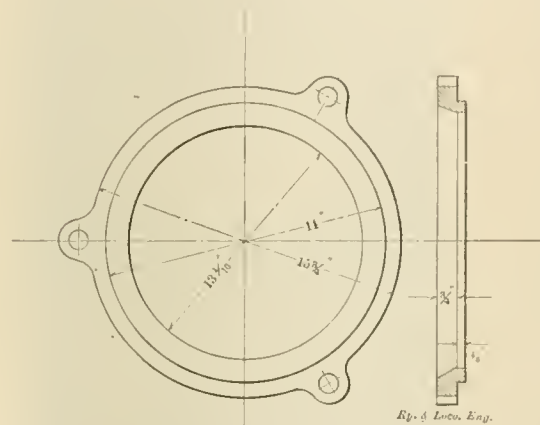

GUIDE FOR PUTTING PISTON VALVES IN PLACE.

valve is entered. Under our old method workmen applied piston valves by pressing in the rings by using tin or other taper wedges, with the result that sometimes hours would be spent, while with this device but a very few minutes are required to apply it, the valves then slip in without any resistance, and the time occupied is only that which is necessary to lift it up and enter. The device has been found to be a very economical one.

The New York Interborough Is a Railroad.

The Interborough Rapid Transit Company, though they operate entirely in New York city, both above and below the street level, have determined to preserve their status as a railroad, equal in point of efficient operation to the best steam roads in the country, and this is proved by the character of the men the company are taking on.

A man to be eligible for a position on the subway division of the Interborough

must be between 21 and 40 years of age. Motormen must be at least 5 ft. 5 1/2 ins. high, and conductors and guards at least 5 ft. 7 ins. They must all be in good physical condition, sound in every member and in the full possession of all their faculties. But these physical requirements are not enough. The kind of men who are obtaining positions on the Interborough in New York are men who have been trained for a couple of years or more on a steam railroad. These men, though they may not at the time of application be familiar with all the duties of a motorman or guard, are, nevertheless, the kind of men this road appears to want, because such men are familiar with train operation. They know the rights of their own train and those of others. They respect block signals and they have some rational idea what to do in case of serious detention or breakdown. They are the kind of railroad men of whom President Roosevelt said in his address to the firemen's convention in Chattanooga. "They know how to handle themselves in an emergency." These men have been trained in the serious responsibilities of train service.

Locomotive engineers, firemen, freight brakemen and freight conductors are the men who, when they qualify, the Interborough employ at the rate of \$3.00 for ten hours' work, for all motormen employed until December 31, 1904. Motormen employed or promoted after that time will receive \$2.75 per day of ten hours for the first year, and \$3.00 per day of ten hours, thereafter. Conductors of subway trains get \$2.10 for the first year, \$2.25 for the second, and \$2.40 after that. Guards, that is men who open and close the platform car doors, employed until January 1, 1905, get \$1.70 for ten hours' work, and after the second year \$1.80, and \$1.95 after the third. These men are eligible for the position of conductor. Conductors and switchmen are eligible for the position of motormen. Hand switchmen get \$2.00 per day the first year and \$2.35 per day after the first year. All these rates apply to a ten hour day. Towermen work from eight to ten hours a day according to location and are paid \$2.40 for the first year and \$2.50 after the first year of service.

The Subway Division will open for passenger traffic some time this fall, but applications have been and are being received by Mr. Frank Hedley, the general superintendent of the road, and should be addressed to him at 16 Dey street, New York city.

A Ten-Hour Clock.

Most clocks run 24 hours a day, but the clock here shown has apparently struck for a ten hour day and has got it. In thus reducing the length of time it has to keep ticking, this clock is in thorough accord with a very ingenious shop time-keeping system, worked out by Mr. Wilfred Lewis, the president of the Tabor Manufacturing Company, of Philadelphia, Pa.

An idea of the amount of "figuring" which has to be done by a timekeeper, can best be appreciated by taking a simple example, which the reader is advised to try for himself. Suppose a piece of work was started at 8.45 A. M. and finished at 3.15 P. M. with 45 minutes to be deducted for the noon meal. If the man who did the work was paid $27\frac{1}{2}$ cents per hour, how much would the job cost? We answer \$1.58, but that answer is with all the figuring left out here and the figuring takes up time and costs money.

The timepiece itself is a cheap Ansonia clock with the gear ratio between the hour and minute hands changed from 12 to 10. A paper dial, prepared in the drawing office of the works, was pasted over the old face. The new dial shows 10 hours and the divisions are into tenths of an hour and hundredths of an hour. The clock thus marking hours and decimals of an hour. The pendulum usually swings freely in a rectangular frame made of two light parallel rods joined at each end by a cross piece. At noon, for example, the cord shown in the engraving, is drawn down and the ring hooked over a peg in the wall. This draws the pendulum up over to one side and compresses the light coil spring on the outside of the clock case. When the clock has to be started again, this detent is let go and the light coil spring draws the rectangular frame to central position again, and the pendulum ticks away as usual.

At 7 A. M., when the whistle is blown, the timekeeper starts the clock. At 12 noon, when the whistle blows again, he stops the clock. It then marks 5 o'clock, and shows that the shop has run five hours. In this particular shop 42 minutes, or seven-tenths of an hour are allowed for rest, but the duration of the "noon hour" does not now enter into the timekeeping problem, as the stopped clock has "cut it out." The man who is responsible for blowing the whistle goes by an ordinary 12 hour dial clock.

Under the timekeeping system employed the men are instructed to enter on their time cards the number past which the short hand stands, and to the right of this, the number past which the long hand stands. These numbers, side by side, are entered on a time card, when a job is begun, and immediately above them two other numbers are placed when

the job is finished. For example, a job is begun at 8.15 A. M. The time entered as shown by the ten hour clock is 1, 2, and if the job be completed at 3.45 P. M. the time as shown by the clock is 8, 0. The difference between these is 6, 8, or 6 hours and eight-tenths, or 6.8 hours. This time paid for at $27\frac{1}{2}$ cents per hour, gives the simple operation in multiplication $6.8 \times .275 = \$1.87$.

The clock can be used as it stands for any length of hours or length of snifts. It is possible to arrange the starting and stopping mechanism of the clock so that the act of blowing whistle will start and stop the clock. The use of this device simplifies the timekeeper's work and eliminates much of the liability to error which exists with methods usually employed.

French Railroads Use Briquettes.

A recent report from John C. Covert, United States Consul at Lyons, France,

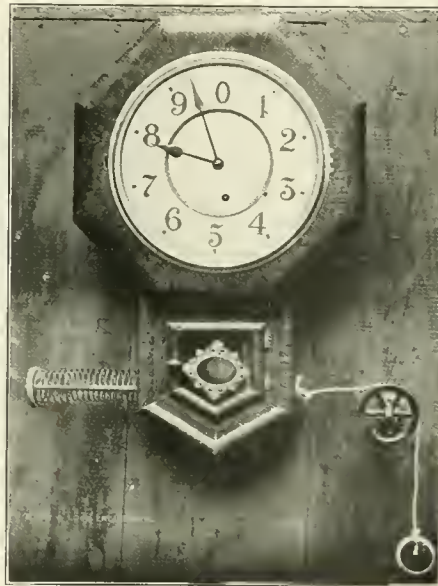

10 HOUR CLOCK.

states that the inspector-general of the Paris, Lyons & Mediterranean Railroad Company has announced that his road uses large quantities of coal briquettes, and that about ten per cent. of that company's fuel consists of this material. The road is thus enabled to use all the slack and coal dust from the mines. The engineers can get up steam more quickly with briquettes than with any kind of coal without them. The briquettes do not form slag or clinkers and tend to prevent the formation of clinkers when used with coal. The company manufactures its own briquettes. About sixty-five per cent. of their fuel consists of fine coal or slack.

The consul also states that a fine specimen of "coaleo," a form of briquette manufactured in St. Louis, Mo., has been received at Lyons, and is attracting a good deal of attention. Coal briquettes

are in very general use in France, hardly a house being without them during cold weather. They are more easily handled and more readily ignited, and also throw out more heat than coal, and they make no dust.

Locomotive Works Washes Clothes for Employees.

The American Locomotive Company have lately installed in their Schenectady works a steam laundry in which the soiled clothes of the employees are washed for a small consideration.

The building now used for that purpose was formerly a rivet store house for the tank department. The laundry is run by a 15 h.p. motor and is equipped with all modern clothes washing machinery, including a 54-in. brass washer for the exclusive washing of overalls and other dirty clothes of coarse material; a 48-in. wood washer for washing fine work; a 28-in. extractor for wringing all clothes; 36-in. body ironer; a 54-in. mangle and all other machines used in a modern steam laundry. A 36-in. fan has been installed for the removal from the building of smoke, steam and foul air, and the sanitary condition of the building is excellent. Four soap tubs are used for mixing soap for the machines, and two tubs are in use for scalding clothes which are suspected of containing disease germs or are infested with objectionable insects. Steam pipes connect with these tubs and nothing could survive the vigorous treatment which is given.

Dirty clothes are collected twice a week, washed and delivered back to the men without delay. A portion of the building has been partitioned off as a dressing room so that the men can change their clothes without leaving the works. Employees are thus enabled to go home looking clean and neat and need not be afraid of carrying the uncleanness of the shop into their homes. All clothes are washed by machinery and no alkalies are used, which might injure the fabric.

Mr. W. J. Lynch general passenger agent of the Big Four, intends to supersede the ordinary design of café car by placing on the road cars which will be known as Dutch grill rooms, they will be patterned after the style of those quaint places which are so popular a department of a modern hotel. The interior woodwork of the car will be of antique oak, with heavy crossbeams carrying wrought-iron lanterns. The floor is to be in red tile. On one side will be a large fireplace, trimmed in blue tile. This traveling grill room will be equipped with specially designed furniture of the old Dutch type. The grill room car will have small Dutch windows and the plate rack will carry a row of ornamental steins.

Of Personal Interest.

Mr. R. F. Hoffman has been appointed assistant to general superintendent of motive power on the Frisco System, with headquarters at St. Louis, Mo.

The controlling interest in the Commonwealth Steel Company has been acquired by Mr. Clarence H. Howard, who represents a syndicate of his friends. The control of the company was purchased from the Niedringhaus firm, which retains a minority interest. The Commonwealth are makers of cast steel, with a monthly capacity of 3,000 tons of open-hearth cast steel. Under the new management the plant will be devoted principally to the making of railroad cast steel specialties. At a meeting of the new company yesterday Mr. Howard was elected president.

Mr. E. H. Harriman, whose portrait we present by courtesy of the *New York Tribune*, is the head of what is often called the Harriman group of railroads, which embrace the Southern Pacific, the Union Pacific, the Oregon Short Line, the Oregon Railroad & Navigation Company and the Leavenworth, Kansas & Western Railroads. Mr. Harriman, from a banker's office, became interested in the Illinois Central, subsequently went



MR. E. H. HARRIMAN.

to the Union Pacific, and eventually bought the Southern Pacific and made it one of his allied lines. Mr. Harriman, some years ago, fitted out a scientific expedition which traveled all over Alaska. It is a difficult thing to get a photograph of this gentleman, and the one we present was reproduced from a snap shot taken as he sits in a trotting sulky, behind a fast horse.

From Office Boy to President.

While trying to inspire our young readers to believe in the great possibilities of advancement in railroad life by those who work and make themselves worthy, an example of what energy, industry and perseverance can accomplish comes to our mind in the success of



PRESIDENT E. T. JEFFERY.

Mr. Edward Turner Jeffery, president of the Denver & Rio Grande Railroad. Mr. Jeffery rose through the mechanical department and rose from the ground floor, for he began railroad work as office boy in the office of the superintendent of motive power of the Illinois Central Railroad. Then he entered the shops as a machinist apprentice, and while going through that course made such good use of his spare time that he was able to enter the drawing office, where he quickly rose to be chief draftsman. A little later he was assistant superintendent of machinery. While holding that position he joined the Railway Master Mechanics' Association, where he proved a very active worker on committees. Higher work however calls him and he is taken away from the mechanical department to be general superintendent of the road, where he began his railroad career. Four years later Mr. Jeffery was made general manager, a position he relinquished two years later to become president and general manager of the Denver & Rio Grande Railroad. A few years ago he moved to New York, where he is understood to be the most valuable practical counselor to Mr. George J. Gould.

Mr. J. E. O'Hearne has been appointed master mechanic of the Wabash-Pitts-

burgh Terminal Railway, with headquarters at Norwalk, Ohio.

Mr. C. S. Morse has been appointed master car builder of the Wabash-Pittsburgh Terminal Railway, with headquarters at Toledo, Ohio.

Mr. R. L. Ettenger has been appointed consulting mechanical engineer of the Southern Railway, with office at Washington, D. C., vice Mr. F. N. Hibbits, resigned.

Mr. Frank H. Whitney, formerly Air Brake Inspector of the New York, New Haven & Hartford Railroad, at Boston, Mass., and late road foreman of engines on the same line, has resigned his position with that road to accept a position as traveling inspector for the Westinghouse Air Brake Co., with headquarters at Boston, Mass.

Mr. Jas. J. Hill, president of the Great Northern Railway Line, is a Canadian by birth. He was born in 1838 and entered railroad service in 1865. He has been local agent St. Paul & Pacific at St. Paul, Minn.; general manager and later general manager and vice-president of the St. Paul, Minneapolis & Manitoba, then president of the same road, and from 1889 president of the Great Northern, a transportation system which now owns the ship which ranks fourth among



MR. JAMES J. HILL.

the world's biggest ships. The S. S. "Minnesota," built at New London, Conn., is intended for trade between Seattle, Wash., and Oriental ports, and is capable of taking as her cargo about 25 train loads of freight, to say nothing of passengers, of which she can accommodate about 2,786, exclusive of her crew. She has triple expansion engines, twin screws, and is capable of maintaining a speed of 15 knots. We present Mr. Hill's portrait by courtesy of the *N. Y. Tribune*.

Mr. Patrick Carey has been appointed road foreman of engines on the Norfolk division of the Norfolk & Western Railroad.

Mr. George Reith has been appointed train master of the North-West Division of the Chicago Great Western Railway, vice Mr. H. M. Eshelman, resigned.

Mr. Harry Richardson has been appointed purchasing agent of the American Locomotive Company's Manchester shops, vice Mr. Bartlett, transferred.

Mr. Theodore N. Ely, chief of motive power of the Pennsylvania, has received the honorary degree of Doctor of Science from Hamilton College, Clinton, N. Y.

Mr. R. J. Morgan has been appointed locomotive foreman at Kamsack, East Assa., on the Canadian Northern Railway. This is a newly opened divisional point.

Mr. C. S. McCarthy has been promoted to the position of general air brake inspector of the entire system of the Intercolonial Railway of Canada, with office at Moncton, N. B.

Mr. W. J. Hatch has been promoted to the position of general air brake inspector on the Canadian Pacific Railway for lines east of Fort William, with headquarters in Montreal, Que.

Mr. John T. Cooper has been appointed road foreman of engines on the Western division of the Delaware, Lackawanna & Western, east of Elmira, N. Y., vice Mr. E. W. Brown, resigned.

Mr. Geo. M. Harleman has been appointed superintendent of the consolidated New York and New Jersey and Lehigh divisions of the Lehigh Valley Railroad, vice Mr. W. O. Sprigg, resigned.

Mr. E. H. McHenry, formerly chief engineer of the Canadian Pacific Railway, has been appointed fourth vice-president of the New York, New Haven & Hartford Railway, with headquarters at New Haven.

Mr. N. Sinclair has been appointed locomotive foreman of the Moncton, N. B., roundhouse on the Intercolonial Railway of Canada. Moncton is the headquarters for the operating and motive power departments of the road.

Mr. W. L. Harrison, formerly master mechanic of the Choctaw, Oklahoma & Gulf, at Little Rock, has been appointed master mechanic of the Cedar Rapids shops of the Chicago, Rock Island & Pacific, vice Mr. Geo. W. Taylor, resigned.

Mr. W. S. Templeton, formerly general foreman of the Sansalito, Cal., shops of the North Shore Railroad, has been appointed master mechanic of the Guatemala Central Railroad, with headquar-

ters at Guatemala City, Guatemala, Central America.

Mr. Frank N. Hibbits, formerly consulting engineer on the Southern Railway, has been appointed mechanical superintendent of the New York, New Haven & Hartford Railroad, with office at New Haven, Conn., vice Mr. J. Henney, resigned.

Mr. Wm. H. Armstrong, formerly manager of the New York business for the Chicago Pneumatic Tool Company, is now associated with the Ingersoll-Sergeant Drill Company, of 26 Cortlandt street, New York, and will look after the interests of the Pneumatic Tool Department.

Mr. L. H. Raymond has been appointed general foreman and acting superintendent of the West Albany shops of the New York Central system. He is a man of marked ability, and previous to this appointment held the position of general foreman of the Boston & Albany shops at Springfield, Mass.

Mr. W. W. Brownhill, locomotive engineer in active service on the Chicago, Rock Island & Pacific, and Mrs. Brownhill celebrated their golden wedding anniversary not long ago, in their home on Delaware street, Leavenworth, Kan. A number of beautiful gifts were presented the happy couple by their numerous friends. Mr. and Mrs. Brownhill most hospitably entertained about forty guests at dinner on the occasion.

Mr. H. J. Raps, formerly foreman of the boiler shop at Cedar Rapids, Ia., on the Chicago, Burlington & Quincy, has resigned that position to take charge of the repair and maintenance of boilers on the Toledo, St. Louis & Western Railroad, with headquarters at Frankfort, Ind. On the occasion of his leaving the "Q." Mr. Raps was presented with a gold watch by the men in his department as a token of regard and esteem. Mr. Raps is a well known contributor to the columns of RAILWAY AND LOCOMOTIVE ENGINEERING, and his communications are invariably read with profit and pleasure.

Mr. J. W. Oplinger, formerly mechanical inspector of the Atlantic Coast Line Railroad, has been appointed superintendent of that road, with headquarters at Savannah, Ga. He began railroad work in 1874 as a machinist apprentice on the Central Railroad of New Jersey, at Ashley, Pa. In 1880 he went to the Lehigh Valley Railroad, at Wilkesbarre, Pa. Four years later he went to the Santa Fe in New Mexico. In 1887 he returned to the Ashley shops of the C. R. R. of N. J. as gang foreman, and in 1900 he became master mechanic on the Atlantic Coast Line, from which position he has risen to be chief of the motive power department.

Mr. George W. Taylor, formerly master mechanic of the Cedar Rapids shops of the Chicago, Rock Island & Pacific, was, on the occasion of his resignation from the service of that company, presented with a handsome diamond shirt stud by about three hundred of the employees of all departments of the Cedar Rapids shops. Mr. Taylor was completely taken by surprise at the appearance of the large deputation headed by Mr. Lawler, but that gentleman pleasantly explained that no strike was imminent and no "demands" were to be made, but that all had come together to express their sincere regret at losing their master mechanic. Mr. Taylor responded suitably and congratulated the men upon their loyalty to the company's interests and to himself. Mr. Taylor has been appointed superintendent of motive power and equipment of the Toledo, St. Louis & Western Railroad, commonly called the Clover Leaf Route. His office is in Frankfort, Ind.

Mr. F. A. Chase, general master mechanic, Missouri District, on the Chicago, Burlington & Quincy, has been appointed general mechanical inspector, and the office of general master mechanic has been abolished. Mr. Chase began his railroad career as a newsboy on the Sullivan Railroad in 1849, and the next year he entered the machine shop at Windsor, Vt., as an apprentice. Later he worked in the machine shop of the South Carolina Railroad, at Charleston, S. C. In 1857 he was employed in the Detroit Locomotive Works, and the following year he went to work as machinist in the Aurora shops of the C., B. & Q. While on that road he worked as fireman, engineer, roundhouse foreman and master mechanic. On the Hannibal & St. Joseph he held the positions of master mechanic and general master mechanic. He also held similar positions on the Keokuk & Northwestern, the St. Joseph & Council Bluffs Railroad, the Chicago, Burlington & Kansas City Railroad, and the Keokuk & Western Railroad.

Mr. R. M. Burnett, until recently general foreman of the car department of the Central Railroad of New Jersey, at Elizabethport, N. J., has been appointed assistant M. C. B. of the Erie, with headquarters at Buffalo, N. Y. Mr. Burnett was born in McLean county, Illinois, in 1868. He entered railroad service in the car shops at Denver, Colo., of the Union Pacific, in 1890. The following year he went to Chicago in the service of the Pittsburgh, Fort Wayne & Chicago. In 1892 he was appointed foreman of the car department of the L. S. & M. S., and in August of the same year he was made general foreman of the car department at Chicago on that road. In 1899 he went to the Long Isl-

and Railroad as general foreman of the car department, with office at Richmond Hill. In 1900 he joined the service of the Central Railroad of New Jersey, as general foreman at Elizabethport, which position he has just resigned to take service with the Eric.

A New Peril for the Steam Locomotive.

A new type of electric railway motor was exhibited on August 19 at Schenectady by the General Electric Company. This motor runs equally well with either direct or alternating current, and is thus suitable for the equipment of new lines fed by alternating current only, which may wish to reach the centers of cities where the lines are fed by direct current only.

An excursion was arranged for the editors of the technical and daily press of New York City by the General Electric Company, and the New York Central & Hudson River Railroad Company, a special Pullman chair car being attached to the 8.45 A. M. train, which reached Schenectady at 12.30 P. M. Among those present were Messrs. H. W. Blake, editor of the *Street Railway Journal*; John A. Hill, publisher of the *American Machinist* and of *Power*; Angus Sinclair, editor and publisher of *RAILWAY AND LOCOMOTIVE ENGINEERING*; W. H. Brown, editor of the *Electrical Review*; C. H. Fairchild, eastern editor of the *Street Railway Review*; John Goodell, editor of the *Engineering Record*, and F. E. Schmidt, associate editor of the *Engineering Record*. The *Electrical World and Engineer* was represented by Professor McAllister, of Cornell University. The General Electric Company was represented by Messrs. E. H. Mullin and L. R. Pomeroy, and the New York Central Railroad by Mr. J. K. Le Baron, editor of the *Four Track News*.

On arriving at Schenectady the party was at once conducted to the rooms of the Schenectady Street Railway Company, where luncheon was served. Assembled to meet them were General Eugene Griffin, first vice-president, General Electric Company; Mr. Hinsdill Parsons, fourth vice-president; Professor C. P. Steinmetz, Mr. W. B. Potter, engineer of the Railway Department; Messrs. Armstrong, Priest, Anderson and Greene, assistant engineers of the same department; Messrs. Schlichter and Milch, representing other engineering departments of the company; Mr. A. G. Davis, head of the Patent Department; Mr. M. P. Rice, head of the Publication Bureau, and Mr. J. G. Barry, assistant manager of the Railway Department. Mr. E. F. Peck, general manager, represented the Schenectady Street Railway Company.

After luncheon, the whole party boarded the car, which was equipped with

four of these new motors, for a trip to Ballston, 15.5 miles distant. The car was first run on direct current at 600 volts as far as the new bridge crossing the Mohawk river, about four miles out. Alternating current was then substituted for direct current, and this was used until the outskirts of Ballston was reached, when direct current was resumed. The car was geared for a speed of 43 miles per hour on the level, and this was exceeded on the down grades when a speed of 49 miles an hour was attained.

During the run the traps in the floor of the car were lifted and the motors exposed. They ran perfectly at all speeds, showing no sparking at the commutator with either alternating or direct current.

The alternating current motor as developed by the General Electric Company and installed on the Ballston line is of the "Compensated" type, so named on account of the character of the field winding which fully neutralizes or compensates for the armature reaction. Both the compensated motors and control are adapted for operation on the 2,000 volt alternating current trolley between cities and the standard 600 volt direct current trolley in Schenectady. This ability of the compensated motor equipments to run over tracks equipped with either alternating current or direct current trolley makes their field of application very broad, as the cars can secure all the benefit of running over existing city tracks without in any way sacrificing their running qualities upon suburban sections equipped with alternating current trolley.

The alternating current motor with its inherent advantages of high voltage distribution is eminently adapted to replace the steam locomotive on either high speed passenger or heavy freight haulage work; and as the compensated type of motor is perfectly adapted to operate on both alternating current and direct current trolley, the alternating current motor must be considered a large factor in future suburban railway systems. The compensated motor is essentially a variable speed motor differing in this respect from the multi-phase induction motor whose constant speed characteristics proved so serious a handicap to its successful adoption in railway work.

On the Ballston extension of the Schenectady railway advantage is taken of the ability of the compensated motor to operate with either alternating or direct current. The extension is 15.5 miles in length, including 3.9 miles of city running in Schenectady over tracks equipped with direct current trolley. The interurban section is double track on private right of way, 60 feet wide, laid with 75 pound T rail, gravel ballast with maximum grade of 1.8 per cent. Special

attention has been given to the high speed possibilities of the road and no curve exceeds $4\frac{1}{4}$ degrees.

Center pole bracket construction is used, there being two brackets supporting the two 600 volt direct current trolley wires and a cross arm supporting the two 2,200 volt alternating current trolley wires. The Ballston extension has been operated for several months with direct current equipments, and their operation being continued in part necessitated an additional set of trolley wires for the alternating current equipments which would not interfere with the direct current trolleys. The direct current trolley conforms to standard bracket construction and presents no unusual features, while the alternating current trolley wire is suspended from a $\frac{3}{8}$ inch steel catenary. The alternating current trolley is clipped to the catenary midway between poles and the catenary in turn is hung over porcelain insulators on wooden cross arms, the whole forming a construction of great flexibility with the further advantage of providing excellent insulation with standard porcelain insulators and eliminating the span wires adjacent to the trolley wire, thereby preventing the pole catching should the trolley wheel leave the wire. This method of trolley construction is well adapted to high potential high speed work in both its electrical and mechanical features.

With the alternating current system using a trolley and track return there is an inductive drop in the trolley and rails with an additional loss in the latter case due to eddy currents and hysteresis. Measurements made upon the Ballston line indicate an apparent trolley resistance of 1.3 times the ohmic resistance, and a rail resistance 6.55 times the ohmic resistance.

The form of alternating current trolley adopted for the Ballston line is well adapted to the requirements of steam roads where the local service is taken care of electrically and through passenger and freight handled by steam locomotives, pending a complete change to electrical operation. The trolley wire and insulators being off-center are not exposed to the gases of the locomotive exhaust with consequent deterioration, and furthermore a catenary construction placed off-center can be hung much lower than a standard center wire without interfering with brakemen on freight cars. A low running trolley at the side of the car is also preferable in main line operation as it conforms better to the clearance diagram of such roads without calling for too great a change in height of the trolley wheel or bow. The trolley suspension adopted on the Ballston line therefore affords valuable experience with a form of construction

adapted to the requirements of electrically converted steam operated lines.

The car equipped with the compensated motors weigh 30.4 tons total, without passengers and is geared for a maximum speed of about forty-three miles per hour on level. The car manufactured by the J. G. Brill Company has a thirty-two-foot body, is forty-three feet over all, and a seating capacity of forty-four passengers. The body is mounted upon Brill No. 27 trucks having six-foot wheel base, each truck carrying two compensated motors, each motor equivalent to a fifty horsepower direct current motor, standard railway rating.

After returning to Schenectady from Ballston, the party boarded a high speed direct current car for Albany, which was reached at 4.50 P. M., in time for the fast train arriving at New York at 8 P. M., after an enjoyable and instructive day.

Mr. James W. Lyons announces his resignation as manager of the power department of the Allis-Chalmers Co. His resignation took effect last August. Mr. Lyons has taken this step in order to accept the appointment as consulting engineer to the Elgin Watch Company, of Elgin, Ill., who will erect new and extensive works under his supervision. Mr. Lyons will also engage in other consulting work, and his headquarters will be at Chicago. He takes with him the good wishes of all his former associates in the Allis-Chalmers Company.

The Brotherhood of Locomotive Firemen will meet in the city of Buffalo in annual convention on September 12 next. Mr. C. A. Wilson, first vice-grand master, has been in Buffalo making arrangements for the meeting. It is expected to be a most successful affair.

The Irrepressible Railway Accident.

A very important part of the expenditures made by railroad companies during the last quarter of a century have been devoted to the perfecting of appliances and of methods calculated to promote the safety of travel; yet it is a melancholy fact that the occurrence of railroad disasters have almost kept pace with the increase of mileage. Not many years ago the charge was truthfully made against railroad companies that many fatal accidents were due to want of well known safety appliances, but that charge can no longer be sustained, for the leading railroad companies appear to be exhausting the capabilities of inventions in equipping their rolling stock and their stations with safety appliances. Yet with all that effort, last month has the record of the most appalling accident known to railroad operating in the United States. A train went through a washed out bridge on the Denver & Rio

Grande Railroad, throwing two crowded passenger cars into a raging mountain torrent, blotting the life out of about 110. There have been many sanguinary railroad accidents on the American Continent, but this one has had only one rival in loss of life, a draw bridge accident which happened near Hamilton, Ont., in 1864, when over one hundred persons lost their lives, mostly by drowning.

The development of safety appliances has practically ended the danger of the open draw, but it claimed many victims in the days when the unaided care of the engineer was almost the only safeguard against dropping into the open draw. At Norwalk, Conn., in 1853, a passenger train ran into an open draw and 46 people lost their lives. That was the worst accident of that kind which ever happened, but there were many minor draw-bridge ones which aggregated the loss of hundreds of lives. The most common railroad accident causing loss of life is the collision between two trains; but the failures of bridges, when they happen, entail at one fell blow the greatest destruction of life and property. Before the car stove was banished failures of bridges under passenger trains nearly always resulted in holocausts caused by the red hot stoves setting fire to the inflammable debris of wrecked cars. The first terrible accident of this kind happened on the Lake Shore road in 1867, and was known as the "Angolo Horror." About 45 people lost their lives in that accident, but it was exceeded in shocking, awe inspiring tragedy that resulted from a collision between a passenger train and some cars loaded with oil at Abergele, on the London & North Western Railway, when 33 persons lost their lives mostly by fire.

The exact loss of life resulting from a railroad accident does not impress the public mind so painfully as the manner in which death overtakes the victims. This mental peculiarity imprinted upon people the impression that the Ashtabula accident, which happened in 1876, was the most appalling that ever occurred on this continent, and it is likely to retain that supremacy of horror, although the loss of life was about 80, probably 30 fewer than the Denver & Rio Grande accident. At Ashtabula a bridge spanning a deep ravine collapsed under a double headed passenger train during a terrible snow storm. One locomotive and several passenger cars were precipitated into the chasm and the smashed debris immediately took fire. The human imagination can conceive of nothing more horrible than the condition created by this catastrophe where a mass of human beings, imprisoned by wreckage, were cremated alive.

A bridge failure almost as fatal as that of Ashtabula happened in 1857, eleven

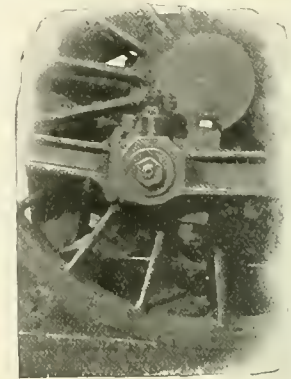

Forestall the Causes of Trouble

and you'll not be stalled on the road with hot-boxes and pins.

Engineers the world over mostly know that, in any emergency,

DIXON'S PURE FLAKE GRAPHITE

will cool a hot pin if it isn't "too late to mend." The same methods may be successfully applied to *keep off trouble*.

An ounce of Dixon's Flake Graphite will save all sorts of trouble if used beforehand and do wonders with your oil credit.

An ounce of prevention is worth a pound of cure. Remember that.

Booklet 69-C is particularly interesting to practical men. Samples of Graphite also upon request. Send for them.

**JOSEPH DIXON
CRUCIBLE CO.
Jersey City, N. J.**

Do You Boil Glue?



ARMY & NAVY LIQUID GLUE

does away with this work. A pure hide and sinew glue in liquid form. No smell; clean and convenient. Will reduce your shop expense for this line of work twenty-five per cent. **The Glue of the Twentieth Century.** Put up in cans, kegs and barrels.

Not a Fish Glue

Samples for testing and prices are yours for the asking.

WACHTER MFG. CO.
BALTIMORE, MARYLAND

years later, at Chattsworth, Ill. Its impression upon the public was less harrowing than that of Ashtabula merely because fewer people died by fire. The particulars of other railroad holocausts are imprinted upon the public memory as those of no other species of life taking seems to be. The first impressive accident of this character happened at Versailles, near Paris, France, in 1852, to an excursion train, when a broken axle overturned a locomotive and spilled three passenger cars loaded with people on top. The wreckage instantly took fire and the loss of life was appalling. Another excursion train accident happened at Campbell station, near Philadelphia, in 1856, a collision having been the original cause of the catastrophe. Five cars loaded mostly with school children were smashed and burned with the result that sixty-six lives were lost and over one hundred persons injured.

Our note books unfortunately contain particulars of so many death dealing accidents of a deplorable character that we cannot, for want of space, even mention the places where they happened. Unfortunately the blood of the martyrs so spilled has not been the seed of prevention, for the record of this year shows the carnage to be unabated. Since the year began we have notes of nine fatal accidents besides that on the Denver & Rio Grande, with the loss of 99 lives and the injury of 301 persons. Seven of the accidents were collisions due to carelessness on the part of some one, mostly of trainmen. These accidents are the harvest of careless selection of men and the lack of proper discipline that might train up inferior material into efficiency. The man who does his flagging in the shelter of the caboose is as common to-day as he has ever been in railway history.

An illustrated catalogue of plane grinding machines made by the Norton Grinding Company, of Worcester, Mass., has just come to hand. In the pages of the pamphlet are to be found illustrations and descriptions of their line of plain cylindrical grinding machines for straight and taper work which revolves on two dead centers. A great deal of work can be economically and accurately done in railroad shops by means of grinding machines and when done that way it is turned out in minimum time. This company also manufacture what they call India oil stones, which are artificially made sharpening stones which can be used not only for ordinary tools but also upon delicately made cutting instruments. The Norton Bench Tool Grinder, with 12 in. wheel $1\frac{1}{2}$ face, is a very handy shop tool and only takes up a space of 16x22 ins. Write the company and they will give you any informa-

tion you desire concerning grinding and will be happy to forward their catalogue to any interested.

The Gould & Eberhardt Catalogue B, which deals with shapers and attachments, is a highly artistic publication. It deals with Eberhardt's patent "Double Triple Quick" stroke shapers. The double triple quick stroke feature which is controlled by a lever on the back of the machine, enables double the number of strokes to be procured than are usually obtained. Through this system the cutting speed can be varied instantaneously to suit the metal being worked. A number of clear half-tone illustrations adorn the pages of this catalogue and in the concluding pages the details of various machines are illustrated and described. There is a telegraphic code given, by the use of which those purchasing these tools may ask questions by wire and receive answers at minimum cost. The address of the company is Newark, N. J. Write them if you are interested, for copy of the catalogue.

The Chicago Pneumatic Tool Company, Fisher Building, Chicago, have issued an illustrated catalogue concerning air compressors. It is not necessary to speak of the excellent presswork or of the beautifully clear half-tones which form the illustrations of the catalogue. About a dozen kinds of air compressors are illustrated, though other sizes are listed and described. In the pages of this catalogue the details of the machines are dealt with and sectional views are given showing the system of jacketing and air cooling which is used. The section of a separate intercooler appears. Toward the end of the book some information is given concerning governors and unloaders, directions for starting and operating compressors, the setting of steam and cut-off valves and the function of the intercooler may be found, and will certainly be read with interest. Write to the Chicago Pneumatic Company either at their general office or at their eastern agency, 95 Liberty street, New York, and they will be glad to send you a copy of the catalogue.

The car and machine shops of the New York, New Haven & Hartford Railroad at Hartford, Conn., will soon close and more than 100 workmen will be transferred to New Haven and East Hartford. At East Hartford the new work will be chiefly on cars. The shops and roundhouse at Hartford which will be vacated have been in operation fifty-five years.

The next convention of the American Roadmasters and Maintenance of Way

Association will be held in St. Louis on September 13, 14 and 15. The selection of St. Louis as the meeting place was made in order to afford members of the association and their friends who attend the convention an opportunity to visit the exposition and see the attractions of the "future great" city.

Somebody who was probably a man of the world, has said that there were three kinds of untruths, and they were facts, figures and statistics. We have had enough general experience of what passes current for railroad "news" to say that there is a certain amount of truth in somebody's opinion. We have now before us some daily newspaper clippings, which calmly state as facts, things which are not true concerning railways and the doings of prominent railroad men.

The American Brake Shoe and Foundry Company, of Mahwah, N. J., have got out a very artistic catalogue dealing with the development of the brake shoe, and explaining and illustrating the company's exhibit at the St. Louis Exposition. The various kinds of brake shoes are shown in neat little half tones with a description of each and a separate view of the inserts which are used, is placed beside each shoe so that its general appearance and the way it is made can be seen at a glance, while the letter press which surrounds the illustration states the function of each, and the use for which each was designed. The company will be happy to send a copy of the catalogue to anyone who will write to them for it.

The O'Rourke Engineering & Construction Co., which firm has the contract for building the Pennsylvania Railroad tunnel under the Hudson river, has placed the order with the Ingersoll-Sergeant Drill Co. for two central compressed air power plants to be located at New York City and Weehawken, N. J. This order includes six, 36 in. stroke Corliss air compressors each of 3,890 cu. ft. capacity. With the O'Rourke plant installed, the total number of Ingersoll-Sergeant Compressors supplying air for subaqueous tunnels in New York will be as follows: 6 Class "A" Straight Line Compressors; 8 Corliss Duplex Compressors; 3 Class "H" Duplex Compressors; and 2 Class "G" Duplex Compressors.

The Rand Drill Company, of 128 Broadway, New York, have had a facsimile reproduction made of a page taken from the Johannesburg Star, weekly edition, which deals with the Mechanical Engineers' Association in South Africa. The subject reported in that issue relates to rock drill tests, and some interesting

facts concerning Rand Drills are given, and Mr. W. C. Docharty's paper is well worth perusal. The reproduction got out by the Rand Drill people is so prepared that a few striking paragraphs have heavy column lines placed beside them, so that busy readers can get at the strong points in the case. The sheet is only printed on one side and can be conveniently folded and addressed, and, in fact, it has been arranged for that very purpose. If you feel interested in the subject send a postal card to the Rand Drill Company and see what these American machines are doing in the "Dark Continent."

The annual meeting of the stockholders of the Locomotive Appliance Company was recently held at their offices in the Chemical Building, St. Louis, Mo., the following board of directors were elected: Mr. W. J. McBride, St. Louis; Mr. J. J. McCarthy, Mr. F. W. Furry, Mr. Edw. B. Lathrop, of Chicago; Mr. J. B. Allfree, of Ironton, Ohio; Mr. Clarence H. Howard, Mr. C. A. Thompson, Mr. W. C. Squire, Mr. Ira C. Hubbell, of St. Louis; Mr. B. F. Hobart, and Dr. G. W. Cale, Jr., of Springfield, Mo. The Locomotive Appliance Company now has Allfree-Hubbell locomotives in successful operation on six of the prominent railway systems of this country.

The Worthington Steam Accumulator is described in bulletin No. 100 by Henry R. Worthington, of 114 Liberty street, New York. It consists of an ordinary steam cylinder, only that it has neither ports nor valve. It is combined with a ram cylinder similar to that of a weighted accumulator. In this case steam pressure is used instead of weight. The regulating pipe consists of a polished perforated pipe which at its closed end is fastened to the accumulator steam piston, and passes into the interior of the steam supply pipe, the joint between the perforated pipe and the cylinder head being made by a long self-adjusting sleeve. The position of the accumulator steam piston which depends on the amount of water stored in the ram cylinder governs the number of holes in the regulating pipe, opening into the interior of the steam cylinder and so controls the amount of steam supplied, and therefore controls the speed of the pump. The whole of the ingenious device will be more fully explained to anyone who will write to Mr. H. R. Worthington at the address given above.

Mr. Roscoe Cornell has been appointed manager of the branch office which the Allis-Chalmers Co. has just opened in El Paso, Texas. Mr. Cornell goes to the Allis-Chalmers Co. from the Mine & Smelter Supply Co., of Denver.

H. S. PETERS'
BROTHERHOOD TRADE MARK **OVERALLS** REGD.

have gone to almost every part of the World where Overalls are worn and are everywhere conceded to be the **BEST**. Every point of material, cut, construction and finish is carefully looked after; the only way that superiority can be attained. Every garment is absolutely guaranteed. The Patented, Fleece-lined, Safety Watch Pocket is alone worth a whole suit of any other make.

I'll send sample suits, charges paid, to any place in the World where mail or express goes, where I have no retail agency; sample materials and full particulars for the asking.

UNION MADE
 OF COURSE —
 B.L.F. 3—H.S. PETERS—B.L.E. 171
 DOVER, NEW JERSEY, U. S. A.

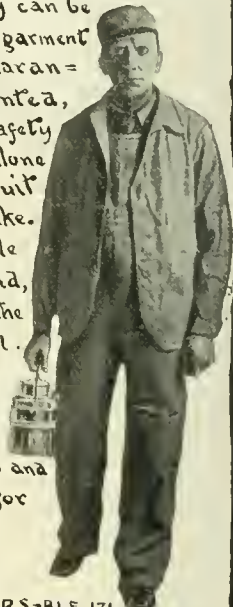

The Twentieth Century Master Mechanic

Won't use solid Mandrels. Cost too much, take up too much room and don't give satisfaction.

Nicholson Expanding Mandrels

Take everything from 1 to 7 inch holes. Take up little room—always ready and you can buy four sets for the cost of one of the solid kind.

Are You Using Them ?

Catalogue tells you more about them.

W. H. Nicholson & Co.
 Wilkesbarre, Pa.

**Keep
Your
Mind
On
It**



**CRANDALL'S HELIOS
AIR PUMP and
THROTTLE VALVE**

PACKING

**Put Up in Sets
Exact Fit to Rod and Box
Send Trial Order**

The Crandall Pkg. Co.
123 Liberty Street
N. Y. CITY
Chicago Office, 30 La Salle St.

The Meaning of the Word Journal.

The word journal is familiar to railroad men as that portion of an axle upon which the brass or journal bearing is applied. The word also means a daily newspaper, and it is now also applied to a periodical, but the derivation of the word is from the French word *journée*, meaning daily, or by the day. Thus we see that a workman who has passed the apprenticeship stage is called a journeyman, not because he may and often does travel about, but because he works by the day.

To trace back the meaning a little further we find that the journal at the end of an axle is called so because it turns, and the word originally grew out of the idea of the daily rotation of the earth on its axis to make a day and from that came the other uses of the word which refers to the regular daily output of work or those things which are measured by a regular period of time. RAILWAY AND LOCOMOTIVE ENGINEERING is a journal in the sense that it appears once every month. Look over the list of things which are not journals and see if there are not some which would interest you?

The first on the list is, of course, RAILWAY AND LOCOMOTIVE ENGINEERING, a practical journal of railway motive power and rolling stock. It costs only \$2.00 a year, and is well worth the money, and besides the paper is a welcome visitor in every household. Let your wife and children see it.

"Twentieth Century Locomotives." Angus Sinclair Co., deals comprehensively with the design, construction, repairing and operating of locomotives and railway machinery. First principles are explained. Steam and motive power is dealt with, workshop operations described, valve motion, care and management of locomotive boilers, operating locomotives, road repairs to engines, blows pounds in simple and compound engines, how to calculate power, train resistance, resistances on grades, etc. Shop tools explained. Shop receipts, definitions of technical terms, tables, etc. Descriptions and dimensions of the various types of standard locomotives. The book is well and clearly illustrated and is thoroughly up to date in all particulars, fully indexed. Just off the press. Price, \$3.00.

"Locomotive Engine Running and Management," by Angus Sinclair, is an old and universal favorite. A well-known general manager remarked in a meeting of railroad men lately, "I attribute much of my success in life to the inspiration of that book. It was my pocket companion for years." We sell it for \$2.00.

"Practical Shop Talks." Colvin. This is a very helpful book, combining instruction with amusement. It is a particularly useful book to the young mechanic. It has a stimulating effect in

inducing him to study his business. The price of it is 50 cents.

"Examination Questions for Promotion." Thompson. This book is used by many master mechanics and traveling engineers in the examination of firemen for promotion and of engineers likely to be hired. It contains in small compass a large amount of information about the locomotive. Convenient pocket size. We cordially recommend this book. The price is 75 cents.

The 1904 Air Brake Catechism. Conger. Convenient size, 202 pages, well illustrated. Up to date information concerning the whole air brake problem, in question and answer form. Instructs on the operation of the Westinghouse and the New York Air Brakes, and has a list of examination questions for enginemen and trainmen. Bound only in cloth. Price, \$1.00.

"Compound Locomotives." Colvin. This book instructs a man so that he will understand the construction and operation of a compound locomotive as well as he now understands a simple engine. Tells all about running, breakdowns and repairs. Convenient pocket size, bound in leather, \$1.00.

"Catechism of the Steam Plant." Hemenway. Contains information that will enable a man to take out a license to run a stationery engine. Tells about boilers, heating surface, horse power, condensers, feed water heaters, air pumps, engines, strength of boilers, testing boiler performances, etc., etc. This is only a partial list of its contents. It is in the question and answer style. 128 pages. Pocket size. 50 cents.

"Care and Management of Locomotive Boilers." Raps. This is a book that ought to be in the hands of every person who is in any interested in keeping boilers in safe working order. Written by a foreman boilermaker. Also contains several chapters on oil burning locomotives. Price, 50 cents.

"Locomotive Link Motion." Halsey. Any person who gives a little study to this book ceases to find link motion a puzzle. Explains about valves and valve motion in plain language, easily understood. Price, \$1.00.

"Machine Shop Arithmetic." Colvin and Cheney. This is a book that no person engaged in mechanical occupations can afford to do without. Enables any workman to figure out all the shop and machine problems which are so puzzling for want of a little knowledge. We sell it for 50 cents.

"Firing Locomotives." Sinclair. Treats in an easy way the principles of combustion. While treating on the chemistry of heat and combustion, it is easily understood by every intelligent fireman. The price is 50 cents.

"Skeevers' Object Lessons." Hill. A collection of the famous object lesson

**Over One
Thousand
Miles
A DAY
on
"The Colorado Special"**

Dinner in Chicago Today
Breakfast in Omaha Tomorrow Morning
Dinner in Denver Tomorrow Evening

**SPLENDID TRAIN SERVICE
to DENVER via UNION PACIFIC**

Full information cheerfully
furnished on application to
G. P. and Tkt. Agt.,
Omaha, Neb.

stories which appeared in this paper several years ago. They are interesting, laughable and best of all they are of practical value to-day. \$1.00.

"Stories of the Railroad." Hill. Best railroad stories ever written. Those who have not read these stories have missed a great literary treat. \$1.50.

"Standard Train Rules." This is the code of Train Rules prepared by the American Railway Association, for the operating of all trains on single or double track. Used by nearly all railroads. Study of this book would prevent many collisions. Price, 50 cents.

"Mechanical Engineers' Pocket Book." Kent. This book contains 1,100 pages 6x3¼ inches of closely printed minion type, containing mechanical engineering matter. It ought to be in the bookcase of every engineer who takes an interest in engineering questions. We use it constantly as a reference for questions sent to us to be answered. Full of tables and illustrations. Morocco leather, \$5.00.

"Locomotives, Simple, Compound and Electric." Reagan. An excellent book for people interested in any kind of locomotive. It will be found particularly useful to men handling or repairing compound locomotives. It is the real locomotive up to date. \$2.50.

RAILWAY AND LOCOMOTIVE ENGINEERING. Bound volumes. \$3.00.

We have received from the American Locomotive Equipment Company, of Chicago, an interesting little pamphlet in which they say something about combustion and the Wade-Nicholson hollow arch for locomotives. The construction of this hollow arch permits the introduction of air into the center of the fire box, and at an increased temperature owing to its traversing the entire length of the arch, the quantity being governed by the size of the openings provided. The arch is made of a specially designed brick with air passages which communicate with the atmosphere through tubes in the back and throat sheets of the fire box. The arch does not necessitate any change in the construction of the fire box or the draft appliances. The entering air is introduced into the box with downward pointing openings to insure complete mixing of air and fire box gases with the object of producing more perfect combustion. This company will be happy to have traveling engineers or master mechanics or indeed any railroad man interested in the subject write them for more information regarding the hollow arch and will send a copy of the pamphlet to any one who writes to them for it.

The Canadian Pacific Railway intends to turn out of their Perth shops, 100 stock and 85 flat cars of 60,000 lbs. ca-

capacity, and also 85 refrigerator cars. The special equipment for all includes M. C. B. axles, Simplex bolsters and patent side bearings, Simplex brake beams, Westinghouse air brakes, Tower couples, Miner draft rigging, dust guards, journal boxes and lids and roller side-bearing trucks.

An innovation in the manner of painting tenders of New York Central engines is being instituted as each locomotive passes through the shop. Hereafter the tenders will not have any number painted on them, the sides and ends will be left plain while the number of the engine will appear in silver leaf under the cab windows. The Rock Island have made a similar rule, the numbers no longer appear on the tank sides of engines which have gone through the shops. The words "Rock Island" are painted on either side of the tender. All tenders of the same class on these roads, may now be said to be strictly interchangeable.

The Duff Manufacturing Company, of Allegheny, Pa., have recently received a contract from the Trans-Siberian Railway Company of Russia for a further supply of Barrett Track Jacks, and this shipment has gone forward as an additional order to the carload order of Barrett Track Jacks received from this railroad some time ago. This company has also received an order for Barrett Track Jacks from the Egyptian Railways, at Alexandria, Egypt, and this consignment has also gone forward. If you would like to have some information about these jacks, which have found favor abroad as well as at home, write to the company and they will be happy to communicate with you.

The Crosby Steam Gauge & Valve Company, of Boston, have issued a pocket folder which deals with the Branden patent rubber pump valve, which is made with a wire coil insertion. The inner coil of the wire forms a nub around the stem, thus preventing the wearing of the hole. These gaskets, while flexible, make a good watertight seat and so maintain the efficiency of the pump by preventing leaks. Another feature is that they are able to bend over a temporary obstruction on the seat, and subsequently regain their original form. Write to the Crosby people for copy of the folder.

Allen J. Weeks, Marion, Mass., has a colored print of the "Noah L. Wilson," of the Marietta & Cincinnati Railroad, of which he would like to find out the history. If any of our readers can oblige Mr. Weeks, their help will be appreciated.

Besides **ASHTON** LOCOMOTIVE STEAM GAGES



WE MAKE

Duplex Air Gages
Gage Testers
Blow-off Valves
Chime Steam Whistles
Pop Valves

ALL OF A SUPERIOR QUALITY

Catalogue L on Application

The Ashton Valve Company, 271 Franklin Street, Boston, Mass.

American Locomotive Sander Company

13th & Willow Sts., Philadelphia, Pa.

Proprietors and Manufacturers,

LEACH, SHERRURNE, DEAN, HOUSTON, "SHE" and CURTIS **SANDERS**

JUST PUBLISHED

—THE—

LOCOMOTIVE UP TO DATE

The greatest accumulation of new and practical matter ever published treating upon the construction and management of modern locomotives, both

SIMPLE and COMPOUND

By **CHAS. McSHANE**

Author of "One Thousand Pointers for Machinists and Engineers," Special Exhaustive Articles were prepared for this new book by the

Baldwin Locomotive Works
Rogers Locomotive Company
Schenectady Locomotive Works
Pittsburg Loco. and Car Works
Brooks Locomotive Works
Dickson Locomotive Works
Cooke Loco. and Machine Co.

Richmond Loco. and Machine Co.
With contributions from more than one hundred prominent railway officials and inventors of special railway appliances.

736 Pages, 6x9 Inches 380 Illustrations

An Absolute Authority on All Subjects relating to the Locomotive

Bound in Fine Cloth, \$2.50

ONE THOUSAND POINTERS

—FOR—

MACHINISTS and ENGINEERS

By **CHAS. McSHANE**

(Practical Machinist)

Assisted by CLINTON B. CONGER, Air Brake Expert; J. P. HINE, Mem. Div. 37, B. of L. E.; J. G. A. MEYER, Mechanical Engineer; W. M. F. GOSS, Mechanical Engineer; JNO. C. WHITE, Indicator Expert. The only complete work on the locomotive combining both theory and practice. 342 pages, 187 illustrations.

BOUND IN FINE CLOTH, \$1.50

The only book ever endorsed by the International Association of Machinists. Agents wanted everywhere; write for terms, commissions and club rates. Will be sent prepaid to any address upon receipt of price.

GRIFFIN & WINTERS, Pub.
171 La Salle St., CHICAGO, ILL., U. S. A.

Vest Pocket Combination Tool



Wire Cutter, Screw Driver, Glass Cutter, Packing Hook and Burner Grip. Weight 4½ oz. Drop Forged Steel. Always useful. Ever Ready.

In Leather Case. Price, \$1.50

WILLIAMS, FROST & CO.
WINONA, MINN.

THIS



BOOK

on pumping, air-compressing and condensing machinery is

Given Away

by each of the following companies:

Henry R. Worthington
Laidlaw-Dunn-Gordon-Co.
Blake-Knowles Steam Pump Works
Deane Steam Pump Works
Clayton Air Compressor Works

114-118 Liberty Street, New York

Flexible Spout

Vertically in straight line. Also laterally. The latest Improvement to

Poage Water Columns

American Valve and Meter Company
CINCINNATI, OHIO.

SEND FOR CATALOGUE

The Higley Cold Metal Saw.

The principal thing which strikes an observer as he looks at a Higley cold saw at work is the way it is driven. You have seen a man take hold of the spokes of a cart wheel when his vehicle is well nigh stuck fast, and help the tugging team. He catches the spokes near the rim and pushes on them with might and main; well, that is pretty much the way a Higley saw is driven. Motion is given to the saw blade by a sheer steel sprocket wheel meshing in radial slots placed as near the periphery as possible. The slots, however, leave sufficient depth beyond to permit of the frequent regrinding of the saw.

On machine size No. 21, which you can see in the P. & R. shops at Reading and in other railroad repair plants, the saw blade is carried in a carriage having a horizontal travel of 45 ins. This makes it possible to make very long, straight or angle cuts. The blade is held firmly in place by four adjustable wearing plates which

lots of hard work and stay at it, and on account of its strong, positive drive, but because of the conveniences provided. Work can, if desired, be clamped on both sides of the blade. This is often necessary, especially when sawing out the ends of locomotive connecting rods, or when handling steel foundry work. The Higley saw takes hold of all sorts of operations where the dividing of metal is work in hand, and it does it quickly and well. In the matter of economy it makes a good showing in running some more pretentious machine tools hard for first place. There are a good many more things that can be done with a good cold saw than a casual observer would imagine. To get a good idea of the whole thing you ought to see The saw saw, or, failing that, write to the J. R. Vandyck Company, 8 Dey street, New York City, and ask for particulars.

The Canadian Government officials have caused the arrest of Mr. R. Bacon.

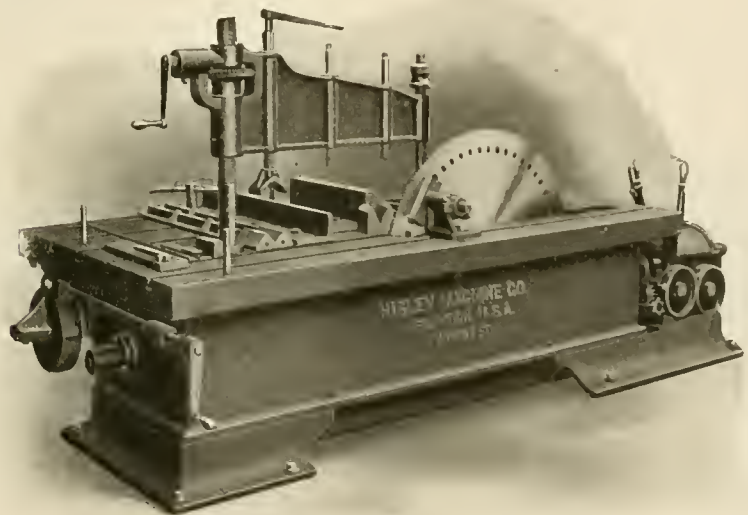

HIGLEY COLD METAL SAW.

keep it rigidly in line. The sprocket method of driving has stood the test of time as it has been in satisfactory use for ten or twelve years on Higley saws. By drawing the saw through the work, so to speak, as is done here, where the power is applied close to the teeth, it is possible to cut very much faster than it is with a saw driven by the rotation of its arbor. The sprocket driven blade is not liable to buckle when the machine is forced. The saw table has a moveable gibbed section, giving a side adjustment of 3 ins. The feed is of the friction variety, and is adjustable for various classes of work and the machine is provided with automatic stop and quick power return.

This cold metal saw has proved to be a very popular tool in railroad shops not only on account of its ability to do

an American civil engineer, on the grounds that he violated the Canadian labor law by going to Canada under contract by the Grand Trunk Railway Company. His deportation to the United States has been ordered, but application for a stop of proceedings has been made under the claim that the United States permits professional Canadians to come to this country under contract and that the Canadian alien labor law is reciprocal.

A neat little pocket pamphlet of about half a dozen pages has been issued by the Consolidated Railway Electric Lighting & Equipment Company, of New York. In it, what is called the "Axle Light" system is briefly described, and each of the parts which go to make up the equipment is separately treated in a short paragraph.

so that a good general idea of the system can be had by a perusal of the little book. It must be remembered that the "Axle Light" system not only provides for the lighting of railroad coaches with incandescent electric lamps, but it renders the use of electric fans possible. This latter feature not only helps to ventilate the coach but it is a positive boon to the traveler in the hot summer months.

New Triple-Cylinder Floorer.

The attention of our readers is invited to this new and improved flooring machine. This class of machine has been a very successful line with the makers, and they, without hesitation, claim this as one of their best and newest. It was patented March 20, 1900, and is designed for those who make flooring, ceiling, siding, casing, etc., in large quantities. Consideration of some of its points will prove interesting.

It planes four sides 9 and 14 ins. wide and up to 6 ins. thick, and by the use of an endless belt apparatus, 1½ in. stock can be matched to advantage; this last device being a new feature. The massive frame prevents vibration, resists all strain and the machine can be run at a very

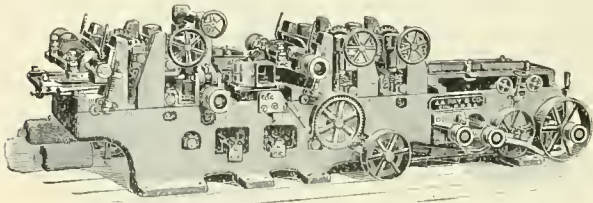

No. 17 TRIPLE-CYLINDER "LIGHTNING" FLOORER

high rate of speed if desired, while under absolute control of the operator. The feed is six large, powerfully driven rolls, having expansive gearing, and which can easily be raised and lowered. The feeding-out one is provided with scrapers, and the rate of feed can be as desired.

The improved matcher works are very heavy and powerful in all parts; the three cylinders are four sided and slotted and furnished with chip breaking lips to work cross-grained or knotty lumber, while the shaving hoods swing outward to give access to the knives. The pressure bars have easy and quick adjustments, and possess many improved points to facilitate their operation. The lower cylinder is vertically adjustable at each end, and the second upper cylinder is at the feeding-out end of machine, being designed to give a light skimming cut. It revolves at a much higher rate of speed than the other cylinders, and fine, smooth work is insured, with all wear compensated by the cylinder raising screws.

Further details, cuts fully describing it, and terms, will be sent by the makers, J. A. Fay & Egan Co., of No. 445 West Front street, Cincinnati, Ohio, to those

interested. This firm will also send free to those who will write for it, their new catalogue.

The Worthington steam hydraulic accumulator is described in Bulletin 100, published by Henry R. Worthington, 114 Liberty street, New York city. This device consists of an ordinary steam cylinder combined with a ram cylinder similar to that of a weighted hydraulic accumulator and is applicable to all purposes requiring the storage of water under high pressure. Its advantages over the weighted accumulator are that it is cheaper and occupies less room, and is free from the shocks and fluctuations of pressure due to the momentum of the heavy weights used on weighted accumulators.

In an article contributed by George H. Daniels, general passenger agent of the New York Central, a description is given of the runs made in Germany last year on an electric railroad when a speed of 120 miles was maintained. That does not appear to have struck Mr. Daniels as a practicable performance for ordinary train service, for he makes a positive assertion that the speed limit of trains has been reached.

The Falls Hollow Staybolt Company, of Cuyahoga Falls, Ohio, have recently received a letter from their Canadian representative, Mr. John Livingstone, in

which he claims that the bolt made at the Falls Hollow staybolt factory, being hollow, adds to its flexibility, and that as there is a current of cool air passing through it all the time, the bolt does not expand quite as much as if it were solid, and that any reduction of diameter expansion of the bolt is a benefit. The claim is also made that the introduction of air above the fire helps to mix oxygen and the coal gases thoroughly and thus secure more perfect combustion. The hollow bolt gives warning if it should break, and the warning is sure because the hole through the center of the bolt is always kept clear and never can become clogged by reason of the constant flow of air through it.

Mr. George Seidel, formerly master mechanic on the Southern Railway at Birmingham, Ala., has been appointed master mechanic in charge of the Chicago, Rock Island & Pacific shops at Horton, Kan.

Prudence, patience, labor, valor; these are the stars that rule the career of mortals.—Lord Lytton.

The TAYLOR-NEWBOLD Saw

Cuts easily a .35 carbon forging 9 ins. by 14 ins. in 17 minutes. Inserted cutters treated by the Taylor-White Process under exclusive rights.

30 Cutters in 36 in. Saw may be changed in 12 minutes.

A set of cutters hardly dulled in two weeks' continuous cutting night and day.



THE TAYLOR MFG. CO.

18th and Hamilton Sts.
PHILA., PA.

30-32 South Canal Street
CHICAGO, ILL.

84 Mason Building
BOSTON, MASS.

40 Deansgate
MANCHESTER, ENG.

Fenwick Freres
PARIS

Schuchardt & Schutte
BERLIN

Patents.

GEO. P. WHITTLESEY

McGILL BUILDING WASHINGTON, D. C.

Terms Reasonable. Pamphlet Sent

The Union Switch & Signal Co.

Consulting and Manufacturing
Signal Engineers.

GENERAL OFFICES AND WORKS AT
SWISSVALE, PA.

DISTRICT OFFICES:

New York: Central Building, 143
Liberty Street.

Chicago: 1536 Monadnock Building.
St. Louis: Terminal Station.

The Newton Cold Saw Cutting Off Machine.

The machine here illustrated shows the saw spindle extended so as to carry two saw blades, by which two cuts can be made in a crank web at the same time. To accommodate the varying width of throats the spindle is fitted with a number of washers or collars which are made of various thicknesses. The blades are keyed on the spindles in addition to the four driving pins which are shown in the illustration. The spindle is driven through gearing by a phosphor bronze worm wheel and hardened steel worm of steep lead. The saw carriage has a variable automatic feed governed by friction disk and power quick return; both of these movements have an automatic throwout.

The work tables are arranged so that if the machine is used with only one saw blade, both cuts can be made without unclamping the work. When one blade is

required to make the cuts was 17½ minutes. The stock used in this crank was exceptionally hard forged steel of about .47 per cent carbon. The saws used on this occasion were the Taylor-Newbold saws, made by the Tabor Manufacturing Company, of Philadelphia, which were illustrated in our June, 1904, issue.

We have received several artistic little pamphlets, which have been issued by the Joseph Dixon Crucible Company, of Jersey City, N. J., any one of which is well worth perusal. For instance, Graphite Afloat and Afield is an explanation of many of the pure flake graphite preparations of the company. Oil vs. Grease, answers some questions respecting the lubrication produced by each kind and sets forth the advantages of the Dixon's graphite greases. Graphite as a Lubricant contains notes upon its manifold usefulness as an accessory for

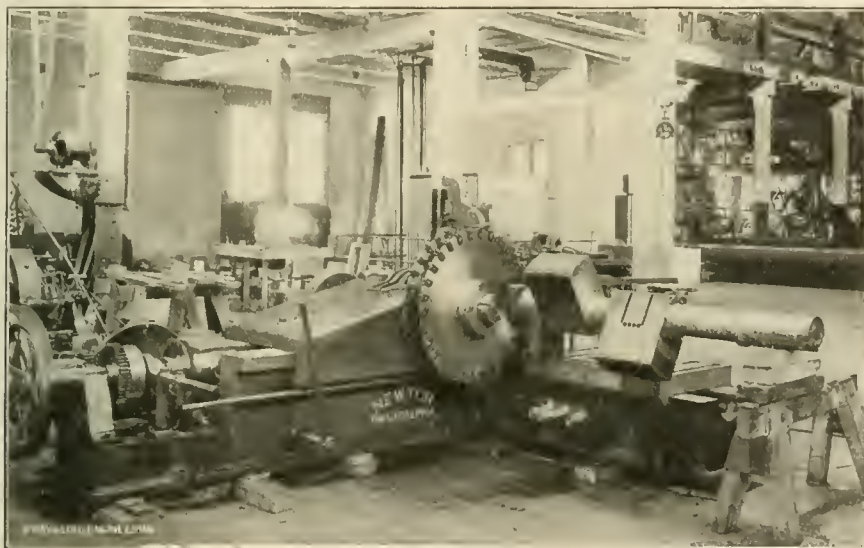

NEWTON COLD METAL CUTTING OFF MACHINE WITH TAYLOR-NEUBOLD SAW.

used the crank is set on V-blocks and the carriages adjusted the proper width apart. The crank is then clamped, and after the first cut is made the tables are moved across the bed simultaneously, by means of the idler and slip gears shown in photograph.

The machine carries either one or two saw blades, as desired, 36 ins. in diameter, and cut to a depth of 11½ ins. The machine can also be used for round or square stock up to this capacity. The crank shaft, shown in the illustration, was used in testing this machine in the Newton Machine Tool Works, of Philadelphia, before shipment. In this case it was merely set on blocks and wedged up, as shown.

The web of the crank was 8¼ ins. wide; the blades, which are ½ in. thick, were set 5¾ ins. apart; the depth of cut being 5⅝ ins., the periphery cutting speed of the saws being 55 ft. per minute; time

engineers. Dixon's Graphite Cup Greases, Dixon's Graphite Pipejoint Compound, Dixon's Ticonderoga Graphite Grease are three smaller pamphlets. Any or all of these will be sent to any one who is sufficiently interested to apply to the company.

The Kennicott Water Softener Company, Railway Exchange Building, Chicago, have issued a most interesting pamphlet on water softening on the Union Pacific Railroad. The brochure is from the pen of Mr. A. K. Shurtleff, assistant engineer of that road, and contains some instructive figures as to engine performance after the use of treated water had been introduced. The increase in average monthly engine mileage is given at 27 per cent. The increase in gross ton-miles made per pound of coal burned was 7½ per cent., and decrease in expensive boiler repairs

Q and C Priest Snow Flanger

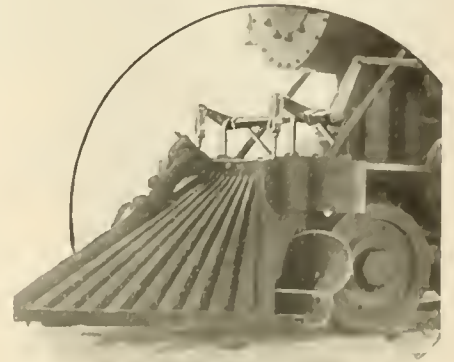

Order now. Don't wait till winter. Send for catalogue.

RAILWAY APPLIANCES CO.

OLD COLONY BUILDING, CHICAGO
114 LIBERTY STREET, NEW YORK

THE ROBERT W. HUNT & CO.
Bureau of Inspection, Tests and Consultation,
1137 THE ROOKERY, CHICAGO.
66 Broadway, New York. Park Building, Pittsburgh.
31 Norfolk House, London, Eng.

Inspection of Steel Rails, Splice Bars, Railroad Cars, Wheels, Axles, etc. CHEMICAL LABORATORY—Analysis of Ores, Iron, Steel, Oils, Water, etc. PHYSICAL LABORATORY—Test of Metals, Drop and Pulling Test of Couplers, Draw Bars, etc.

Efficiency Tests of Boilers, Engines and Locomotives.



CUT OUT

this Ad., fill in your name and mail to us, and we will send you printed matter from time to time as it comes off the presses.

It may be convenient for you to be among the first posted.



TATE Flexible Staybolt

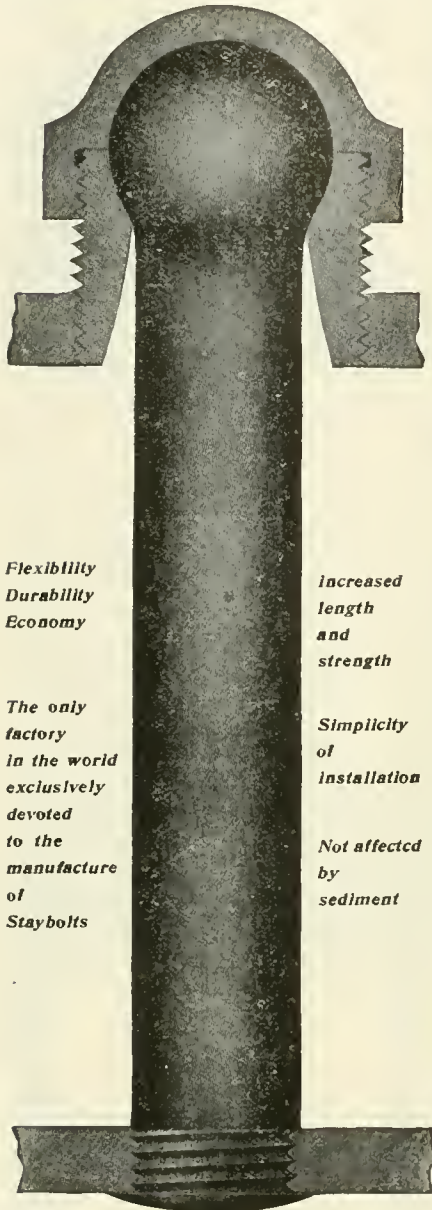

*Flexibility
Durability
Economy*

*The only
factory
in the world
exclusively
devoted
to the
manufacture
of
Staybolts*

*increased
length
and
strength*

*Simplicity
of
installation*

*Not affected
by
sediment*

FLANNERY BOLT CO.
PITTSBURG, PA.
Works: Bridgeville, Pa.

due to treating bad water per engine mile was 34 per cent. The total treating capacity of the plants was 3,000,000 gallons each day and the installment was thirty-six Kennicott water softeners. The report says that about 3,000,000 gallons of water are daily treated and that over three tons of incrusting solid matter is removed at an additional cost to the water supply of 2.32 cents per 1,000 gallons. As the consumption increases the cost will come down. Two very interesting tables are printed on the last pages, and the whole is well worthy of the careful perusal of any railroad man who is seriously interested in the removal of incrusting and foaming solids

from the water used in locomotives doing heavy work. The pamphlet has quite a number of good illustrations and the article ought to be widely read. The Kennicott Water Softener Company will be happy to mail free, a copy of this interesting statement of work accomplished to anyone who will signify a desire to have one by sending them a postal card containing the request.

The Nerst Lamp Company, of Pittsburgh, have issued a small descriptive pamphlet on the system of lighting the streets of Berwyn, Ill., with Nerst lamps. Being a municipal plant, the City Hall is lighted from the system. No light is sold to private consumers. This system is an interesting one from the fact that Berwyn relies entirely on the Nernst lamps for its street illumination. Charles W. Carman, consulting engineer of Chicago, had charge of the design and installation of the plant.

The United States Metallic Packing Company, of Philadelphia (427 North Thirteenth street) have just issued a small catalogue of their metallic packing which is intended for use on stationary and marine engines. These styles of U. S. metallic packing are made for use on railroad shop engines and on the engines of the floating equipment, which is now part of so many of our large railway systems. The main claim made for this packing is its flexibility; no matter how badly an engine is out of line or how much play there is between cross-head and guides, the packing floats with the rod and offers little resistance. The flexibility is due to the combination of a ball joint, with the sliding face of the vibrating cup. Write to the company if you would like a copy of the catalogue explaining all this fully.

The Hancock Inspirator Company, of 85 Liberty street, New York, have sent us a small pamphlet describing their type E inspirator for locomotives. It is the latest type made by this firm. It is made in sizes capable of delivering 2,500, 3,000, 3,500, 4,000, 4,500 and 5,000 gallons per hour and as all these variations can be made by the simple change of nozzle and tube still retaining the standard size of inspirator. The inspirator, which is a lifting one, is therefore universally interchangeable, and the pipe connections are standard. This company will be happy to send the pamphlet, or any information concerning boiler feeding appliances to anyone who will take the trouble of dropping them a postal card to that effect.

The Union Switch & Signal Company, of Pittsburgh, Pa., have just got out bulletin No. 20, on automatic block signaling, and this issue deals with the polar-

The BARRETT GEARED RATCHET CAR JACKS



No. 29. 25 Tons Capacity.
No. 30. 35 Tons Capacity.

IMPROVED QUICK ACTING JACKS

for the rapid handling of Empty or Loaded Cars and Coaches and for Locomotives.

Easy to Operate, and they have no intricate parts or complicated features. Have all the simplicity of the ordinary Lever Jack, and are more reliable and better adapted to car work than either Hydraulic or Screw Jacks.

Send for Special Bulletin "L"

MADE ONLY BY
THE DUFF MANUFACTURING CO.
Works: Allegheny, Pa. PITTSBURG, PA.
FAIRBANKS, MORSE & Co., Chicago,
Agents for Railroad Dept.

GINSENG Fortunes in this plant. Easily grown. Roots and seeds for sale. Room in your garden. Plant in Fall. Booklet and Magazine 4c.
OZARK GINSENG CO., DEPT. Y-15, JOPLIN, MO.

CONTENTS.

	PAGE.
Air Brake Department.....	413
*Valves, Triple, vs. Plain.....	413
*Brake, Hand, on Cars.....	414
*Pressure, Detect Fall of, in Pipes.....	415
Book Reviews.....	409
*Car, New Smoker for Erle.....	412
*Clock, Ten hour.....	422
Editorial.....	406
Car Construction, Steel in Passenger.....	407
Examinations on New York Central.....	408
Foreman, Work of Road, of Engines.....	408
Locomotive, Passing of "American".....	406
Steel, Break in Price of.....	407
Foremen, Fair Treatment for Round House.....	399
General Correspondence.....	399
*General Manifold Company's Plant.....	420
Grate, Large, Surface.....	400
*Journal, Renewal of, Collars on Boston "L".....	404
*Locomotive, Growth of the, by Angus Sinclair.....	392
Pennsylvania, Testing Plant.....	411
Record Board.....	399
Stevens, on Southern Pacific.....	403
2-6-2 for Long Island.....	397
4-6-0 for Michigan Central.....	419
4-8-0 for Great Northern.....	405
Locomotive, New Peril for Steam.....	425
Personals.....	423
*Piston Valve Guide.....	421
Questions Answered.....	410
Railroad, New York Interborough.....	421
Race, Trans-Continental, with Mail.....	391
*Sander, Locomotive, for Wet Sand.....	398
*Stay, New Radial Crown.....	402
Stories and Narratives:	
Old Time Railroad Reminiscences, by S. J. Kidder.....	395
Reminiscences from Apprenticeship, by J. B. Phillips.....	402
*Tunnel Pennsylvania R. R.....	401
*Valve, Cut-out.....	401
*Wheels, Boring Car.....	401

ized or "wireless" track circuit system. Briefly this is an explanation of how the track circuit battery when short-circuited by the entrance of a train in the block puts the home and distant signals on the post behind the advancing train to the stop and caution positions, and also explains why it is that through the action of a polarized relay when the train leaves block A and enters block B, the home at A clears, but the distant at A remains at caution until the home at B has fallen to the clear position. It is a very clever piece of automatic electrical mechanism, and any one who desires to understand it ought to apply for this bulletin.

Railway and Locomotive Engineering

Copyright by Angus Sinclair Co.—1904

A Practical Journal of Railway Motive Power and Rolling Stock

Vol. XVII.

174 Broadway, New York, October, 1904

No. 10

The Mount Pilatus Railway.

Close by that beautiful sheet of water, Lake Lucerne, in Switzerland, rises the famous mountain which takes its name from a legend connected with the last unhappy years in the life of Pontius Pilate.

like steps on a stairway, and each compartment accommodates 8 persons.

This road is, of course, a rack railway; four pair of gear wheels, two in front and two behind, are used for propulsion and for braking of the vehicle. The racks are set in the center of the track, being placed

free movement of the car, they hold it securely to the track. These sliding rings are also of use in preventing derailment due to snow and ice on the track.

The engine, which can exert about 70 h.p., has cylinders $8\frac{3}{4} \times 12$ ins. The boiler is of the tubular type, 6 ft. long, with 225



TOMLISHORN, WITH FOOT PATH CONSTRUCTED BY THE MOUNT PILATUS RAILWAY TO HIGHEST VIEW POINT OF THE MOUNTAIN.
(Courtesy of the *Scientific American*.)

At Alpnach-Staad, the lower station on this railway, the traveler is really 1,450 ft. above the level of the sea. The car is built to suit the inclined way, which is at that point 36 per cent. The engine and passenger car form one vehicle. The car contains four compartments, arranged

back to back and the teeth are vertical, which position largely prevents the danger of clogging with dirt or other substance. In order to prevent the car from being blown from the rails during a gale, sliding rings or clamps are provided which embrace the rail head, and while permitting

sq. ft. of heating surface, and a working pressure of about 180 lbs. It is set so that the various alterations of grade will produce as little variation as possible in the water level. The average grade is 38.1 per cent., the maximum 48 and the minimum 19.2 per cent. The light weight of

engine and car is about 9.6 tons. The brake mechanism has been carefully designed. It consists of a compressed air brake, an automatic brake and two friction brakes. The engine was built at the Winterthur Locomotive Works, in Switzerland.

The distance traversed by this railway, from Alpnach-Staad to Pitalus-Kulm, is 5,400 ft. The track, however, is 15,150 ft. long. Numerous bridges and tunnels are traversed and when the highest point is reached the traveler is 6,800 ft. above the sea level.

The railway was built in 400 days at a cost of \$380,000. Our illustration shows the locomotive-car passing through Wolfort Gorge.

Water Power and Coal Power.

A great deal of attention is being bestowed by engineers and scientists upon the potential power running to waste in streams and water falls. Some one with a genius for calculations says that the water running from the present land surface to the sea level would produce, if utilized, 10,340 millions horse power for every hour of the day and night. This is much greater than the power that could be produced by the annual production of coal, which is about 225,000,000 tons. That amount of coal, if all used for steam making purposes, would not produce more than 620,000,000 day horse powers.

An English Record Run.

A record has been created by the premier railway of England. On July 1, the Great Western Railway put into operation two new trains which daily travel from Paddington to Plymouth and vice versa, a distance of 246 miles, which is done in 265 minutes, without stopping. This creates a great record for a non-stop run included in the regular service. Longer runs have been made on special occasions on the London and North-western Railway from Euston to Carlisle, 299 $\frac{1}{4}$ miles and also in this country.

Every Man His Own Clamping Device.

If you visit what is curiously called the Fort Wayne Shops of the Pennsylvania Lines West, situated at Pittsburgh, you can see an ingenious device used in dismantling broken air and steam hose.

The device consists of a stout block of wood 14 or 16 ins. high placed upon the ground. At a suitable point a plate of iron has been let in to its upper side, and this plate forms a sort of anvil. At one end of the block there is hinged a piece of spring steel, which carries a seat at the other end, the whole counter-balanced by a weight—which hangs from a pulley on a post nearby.

When the operator wishes to take off

broken hose from a nipple which is to be used again, he lays it on the anvil, leaving the clevis projecting beyond the steel spring, and then he literally sits down on the whole job. His weight effectively clamps the piece of hose pipe in place, and holds it in a most convenient position for working. When he wishes to release the work, he eases up on his seat, and the counter weight on the post carries seat and spring up so that the hose is instantly freed. In fact, the act of standing up to reach another broken piece of hose lets the one which has been dismantled come out of the machine.

The device is simple, and one may almost say it has no maintenance charge, as there is practically nothing about it to wear out. The heavier the man who uses it the firmer the clamp he can get

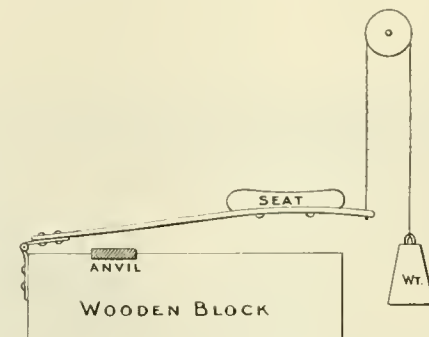

SEAT CLAMP FOR DISMANTLING HOSE.

on the hose, and high pressure is the thing that counts nowadays.

The Train Despatcher.

"The despatcher is known chiefly through his shortcomings, actual or alleged. If there were no bad meeting points and trains were never delayed, it is probable that a large number of railroad men would not know of his existence." This humorous truism, for true it certainly is, was one of the things Mr. H. A. Dalby told an audience composed of members of the Pacific Coast Railway Club at a meeting held not long ago in San Francisco. The title of the paper read was "The Despatcher, Those for Whom and With Whom He Works."

Mr. Dalby pointed out that if an extra train makes a good run over a division the despatcher is, as a rule, not mentioned as being a factor in the case, though he may have "helped" the train over every mile of the road. Just here we are reminded of a saying of the late Grant Allen, concerning the way he wrote those scientific essays which would make even an unscientific man con them over with delight. He said, "Labor, incessant labor, has the appearance of ease." It may be that the good, close work often done by a despatcher may, from its very excellence, have the

appearance of ease, and so completely escape notice.

Another point which was made by the speaker was the fact that post mortem examinations of a train sheet in which all the bad moves are made to stand clearly out, is often very far from just criticism, and the reason is not far to seek. By the sheet you can easily see how the trains did run, but the despatcher had to prophesy how they would run, and he had to make arrangements before the events came off. There is a wide difference, he says, between a review and a preview.

He gives as an example a light train reported ready to start, having a downhill run ahead of it which should have taken about say 15 minutes to accomplish. A train at the bottom of the hill intending to come in, was waiting for a passenger train to get by so that if all had gone well the light train would have been part way down the hill before the up freight was entitled to move, and this detention to the up freight ought to have been slight. The despatcher arranged accordingly. Then the light freight hung back 15 minutes at the start, took 30 to get down the hill, and when the up freight was met, it, the up freight, hung back 15 minutes before starting, claimed an hour's detention and after all was over anybody could have told the despatcher how he should have fixed it.

Still another point was made by the speaker and his remarks should appeal to the despatcher's superior officer. Mr. Dalby held that the despatcher should not be disturbed in his work, nor should he be made to do the work of an operator. "Concentration of thought is a very essential element in successful train despatching." It is not for the mere comfort of the operator that Mr. Dalby pleads, he believes that what he calls "overloading" the despatcher and distracting his attention, is positively dangerous, and he means what he says to be taken seriously.

In the matter of discipline the speaker was opposed to the practice of giving a despatcher a note containing harsh criticism or a "please explain" letter when he was on duty. This, he says, is most unwise for the reason that it unsettles the man while he is doing responsible work and tends to divide his attention.

A good suggestion is that a despatcher be given proper time with pay to go over the road periodically and let him get a look at despatcher's work on the road through a pair of trainmen's spectacles. Lastly upon operators is impressed the great importance of sending full, prompt and accurate reports of all that a despatcher should know, all along the road, and, moreover, he should be told it in time to let him make an intelligent use of it.

Growth of the Locomotive.

BY ANGUS SINCLAIR.

(Continued from page 394.)

BURNING ANTHRACITE COAL.

As anthracite coal had the characteristics of an ideal fuel for locomotives, being cheap in the Atlantic Seaboard States, and free from smoke, there were naturally attempts made from the inception of railroads to utilize it. Yet twenty years after the first locomotive had been operated in the United States, wood was the fuel used by locomotives even when their principal work was hauling anthracite to market.

The Baltimore & Ohio had used anthracite to some extent with success in their locomotives with vertical boilers and forced draft. It had also been used on the Beaver Meadow Railroad and other short lines in Pennsylvania, but very little success had been achieved with it on engines doing hard, continuous work. Early experimenters with coal burning locomotives moved on the theory that concentration was necessary to maintain a very hot fire, and their tendency was to provide limited grate area. It took long years of failure to convince the men in charge of American railroad motive power that anthracite, being a slow burning coal, needed a much larger grate surface than wood or bituminous coal to produce an equal amount of heat.

The Philadelphia & Reading Railroad was the principal anthracite coal carrying line in 1850, but at that time nearly all its locomotives burned wood. Various attempts had been made to burn anthracite but success was attained very slowly. The company had commenced operating with

of G. A. Nichols, a civil engineer, who held advanced views concerning the proper means for burning anthracite. He patented a peculiar form of locomotive to embrace his ideas of an anthracite burning engine. Up to that time the only locomotives burning anthracite successfully had unusually large grates and forced draft. Nichols, thinking that the boiler connecting with the frame carrying the power transmitting machinery of a locomotive could not be made suffi-

and he immediately built four anthracite burning engines to compete with the Novelty. His engines, which were modified camels, had long overhanging fire boxes and they were not allowed to run on account of the excessive weight on the back wheels. Winans then applied a pair of pony wheels under the foot plate and the engines were accepted. They burned anthracite better than any locomotives previously tried and were really the pioneer heavy an-



JAMES MILLHOLLAND.

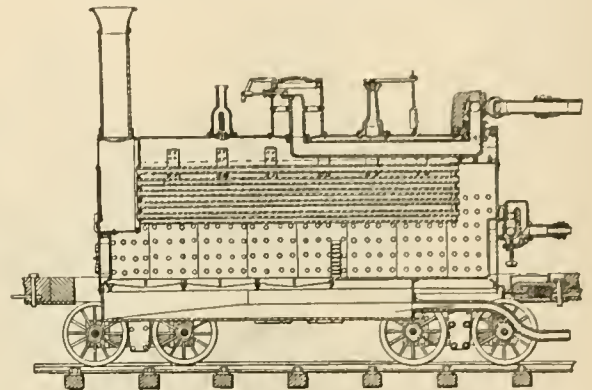

BOILER OF NICHOLS' NOVELTY FIG. 71.

ciently large, designed a boiler to be carried upon a carriage separate from the engine. The locomotive, Figs. 73 and 74, was called the Novelty, and justified the name. The boiler like part of the engine was a steam reservoir which received the steam from the boiler proper through a jointed pipe. The cylinders exhausted the steam into a condenser and drove a blower discharging into the ash pan. The boiler was of the return tubular form and had a large fire box with 36 sq. ft.

of grate area, designed a boiler to be carried upon a carriage separate from the engine. The locomotive, Figs. 73 and 74, was called the Novelty, and justified the name. The boiler like part of the engine was a steam reservoir which received the steam from the boiler proper through a jointed pipe. The cylinders exhausted the steam into a condenser and drove a blower discharging into the ash pan. The boiler was of the return tubular form and had a large fire box with 36 sq. ft.

tracite burning locomotives to do the work of train hauling regularly, the large grate, having 17.68 sq. ft. area, being their principal merit.

CIVIL ENGINEER EMPLOYED TO ADVISE ON BURNING ANTHRACITE.

The management of the Philadelphia & Reading Railroad were not entirely satisfied with Winans' design of anthracite burning locomotives, for we find that in 1849 George W. Whistler, Jr., a civil engineer of some repute, was employed by the president to investigate the question of anthracite burning locomotives. The report submitted was devoted principally to recounting the difficulties experienced in burning anthracite. In some respects his report bears a strong resemblance to others submitted years afterwards to the Railway Master Mechanics' Association by committees. Mr. Whistler reported that it was found that anthracite made such a hot fire that it soon burned out the side sheets of the iron fire boxes. The iron not being free from seams, laminated and blistered so readily, that much expense was entailed. No remedy was suggested, but the company was advised to persist in the practice of using the fuel it was so much interested in carrying.

The employing of Mr. Whistler to report on anthracite coal burning was an act which testified to the influence of the civil engineer in those days. There was a strong tendency to place the knowledge of the man, whose principal experience had been the building of railroads and the digging of canals, above that of the mechanic who had designed, built and operated locomotives, even when it related to purely mechanical matters. The

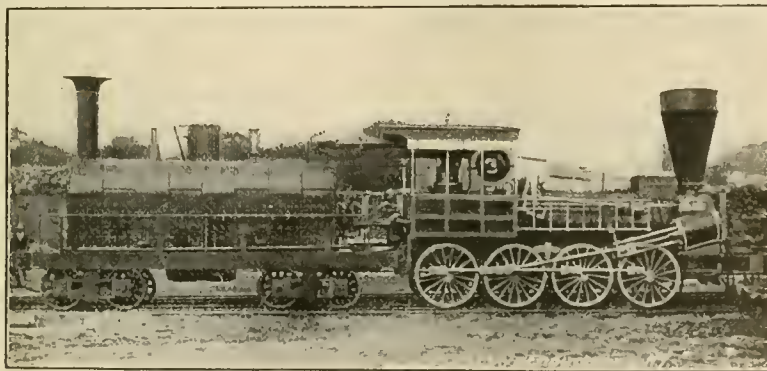

NICHOLS' NOVELTY FIG. 73.

small four wheel Braithwaite engines, somewhat like the Camden & Amboy's John Bull, that had unusually small fire boxes, entirely unsuitable for the combustion of anthracite. For several years all the new engines put upon the road suffered from the defect of small fire boxes.

CURIOUS ANTHRACITE BURNING LOCOMOTIVE.

In 1846 the operating of the Philadelphia & Reading Railroad was in charge

of grate area. The total heating surface was 1,085 sq. ft. The engine was a failure principally for want of the necessary adhesion, but the boiler details were badly worked out for the fire could not be replenished while the draft fan was working, and it was necessary to stop to fire between stations.

This enterprising attempt of the Philadelphia & Reading to produce a special form of anthracite burning locomotive stirred up the emulation of Ross Winans,

civil engineer's calling was old and that of the mechanical engineer scarcely recognized, so it was natural that the representatives of capital should show deference to the views of the civil engineer.

JAMES MILLHOLLAND.

At the time Whistler made his investigations a master mind had been put in charge of the mechanical department of the Philadelphia & Reading, although his powers were not yet recognized. This was James Millholland, a master among

necessary improvements, almost the whole of the required changes having been evolved from his own head. There was little experience of others to draw from, so he was forced to depend upon his own resources to produce the designs best adapted for the work to be done. His controlling idea seemed in the first place to be the production of a locomotive to burn anthracite satisfactorily and then to design an engine capable of hauling a heavier train than anything tried up to that time. He succeeded in both these

Gowan and Marx, the most successful of the first freight engines on the road; but it did not permit of more than 10 or 11 sq. ft. of grate area, and hence was not well adapted to the combustion of anthracite. After obtaining experience with the Philadelphia new and original types were worked out.

SOME OF MILLHOLLAND'S MISTAKES.

The stationary boiler and marine practice of the time led Millholland to believe that a long flame passage was necessary to effect combustion in a locomotive furnace, and he worked very persistently with various forms of combustion chambers until he finally became convinced that they were actually prejudicial to the efficiency of the boiler. One of his first attempts was to produce an anthracite burning fire box that would not damage the side sheets, and with this object in view he patented in 1852 a boiler, the special features of which were the use of dust plates contracting the area of grates for the purpose of preventing the over heating of the side sheets of the fire box, and an intermediate or mixing chamber, into which the products of combustion passed from the fire box between water tables or vertical water spaces, and from which after mixing with fresh air admitted through small holes, they passed through the tubes into the smoke box.

A group of engines was built in 1852 with that type of boiler, the Illinois (Fig. 76) being one of them. The engines had 17 sq. ft. of grate area, which was large for that time, and they were said to have been the first passenger engines to burn anthracite successfully. They were fine engines, with cylinders 17x30 ins. and forged driving wheels 7 ft. diameter.

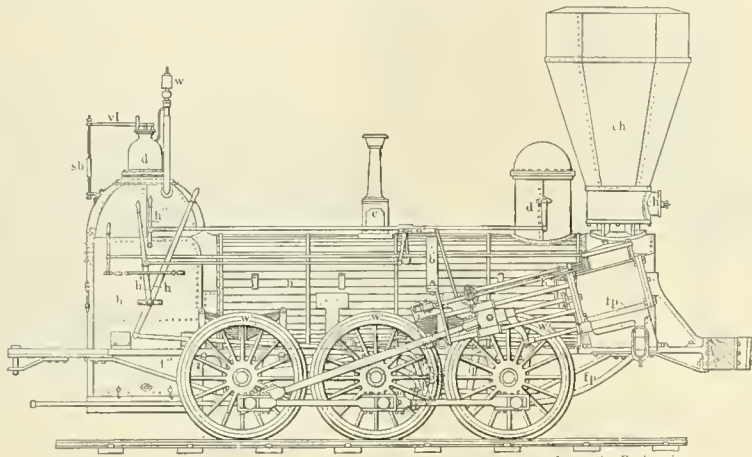

MILLHOLLAND'S PHILADELPHIA. FIG. 75.

the pioneer mechanics whose labors put an indelible mark upon the development of the American locomotive.

James Millholland was born at Baltimore, in 1812, and had time to learn the machinist trade, and held the reputation of being a remarkably bright boy and an ingenious mechanic, when Peter Cooper, in 1830, was building his Tom Thumb locomotive. Millholland worked on that tiny engine, and he no doubt acquired a strong liking for railroad motive power, since he devoted his life to that line of work, at a time when working on railroad machinery had not become popular. He had no more than attained his majority when he was appointed master mechanic of the Baltimore & Susquehanna Railroad, at that time one of the most important railroads in the world. His success was so marked that in 1848 he was appointed master of machinery of the Philadelphia & Reading, with charge of all rolling stock. The road was then ten years in operation, having been constructed in a most substantial manner, with rails 45½ lbs. to the yard, and a most substantial roadbed, at a cost of \$180,000 per mile. In spite of that enormous first cost, the road was doing a profitable business in 1850, for it was then carrying the heaviest traffic of any railroad in the country.

DIFFICULTIES MILLHOLLAND OVERCAME.

When Millholland took charge the rolling stock was in a decidedly unsatisfactory condition, particularly the motive power. He proceeded to carry out the

aims, but success was achieved over some serious failures.

The first locomotive built by Millholland, about 1849, was the Philadelphia, a six wheel connected engine (Fig. 75), without a truck, in which no attempt was made to break away from the beaten path of early locomotive designing. His guiding idea was to produce a locomotive that would haul a heavy train of cars on a crooked track without undue resistance

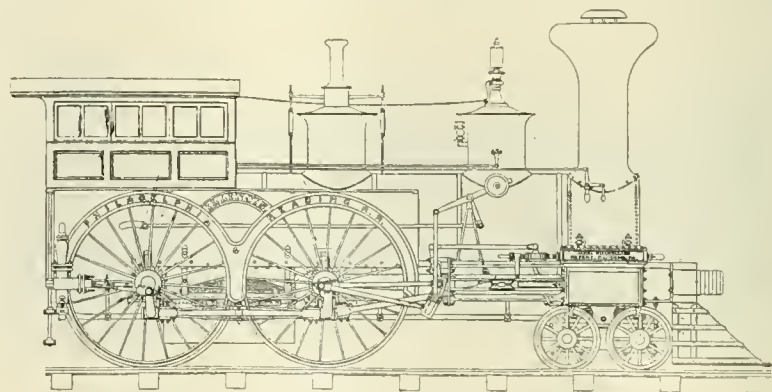

MILLHOLLAND'S FIRST PASSENGER ENGINE. FIG. 76.

or injury to the track. To attain these ends he placed the wheels as closely together as possible. The cylinders were secured outside of the smoke box and transmitted the power to the back pair of drivers, an arrangement that would induce so much oscillation that the engine would furnish good object lessons on defects to be remedied.

The fire box was the Bury style, which had been very satisfactory in the

WORKING OUT DESIGN OF FREIGHT ENGINE.

After producing a passenger engine that was satisfactory to the management, Millholland again directed his attention to the designing of a freight engine and the result of his labors was the engine shown in Fig. 78, which was six coupled and had a single pair of guiding wheels behind the cylinders. The first of this class was built in 1852, and was called the Wyomissing. The second one built

was the Pawnee, after which that kind of engine was named.

This class of engine embraced the greatest advance in locomotive designing made up to that time. The wheel arrangement was the precursor of the Mogul, a single pair of leading wheels having been placed behind the cylinders, but secured to the main frames. The necessity for leading guiding wheels in six-wheel connected engines was no doubt impressed upon Millholland by his experience with the Philadelphia.

The boiler, however, possessed the most novel features. The fire box was placed behind the back driving wheels, providing an unusually large grate. In front of the fire box was a short combustion chamber as shown, then came a set of short flues, 3 ins. diameter, which led the fire gases into a second combustion chamber, thence by small tubes into the smoke box.

The valve motion was a stationary link and shifting block with round eccentric rods fastened to the eccentric straps in a peculiar fashion, the variable exhaust consisting of a movable cone which was lowered or raised by suitable rod connections. The blower opening was on the side of the stack circle, which seems wrong according to modern ideas, but it created the necessary draft. The smoke stack consisted of an inner and an outside pipe, the extra pipe in front having been provided to carry away whatever cinders accumulated between the inner and outer stack pipes.

There was a double seated throttle valve, the first on record as being applied to a locomotive. Two domes were used, a convey pipe making connection between them. There are other peculiarities which can be found on a close inspection of the engraving.

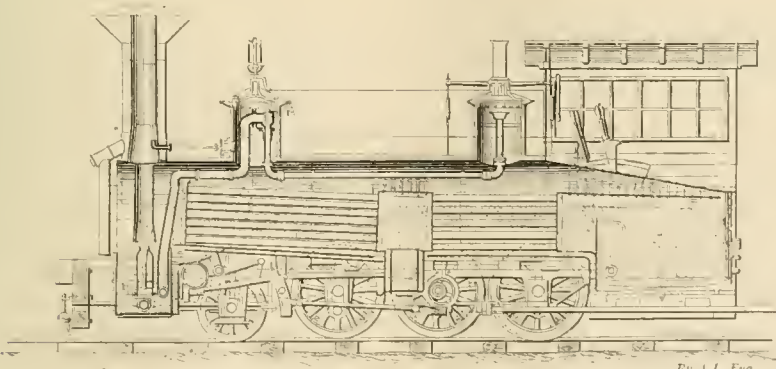

MILLHOLLAND'S 6 WHEEL CONNECTED ENGINE WITH HIS PATENTED BOILER. FIG. 77.

When James Millholland became master of machinery of the Philadelphia & Reading Railroad, the locomotive was very much in an experimental stage as a whole and there was no harmony among builders concerning the material, dimensions and design of the component parts. It was common to have the cylinders secured high up on the sides of the smoke box, transmitting the power through long

reaching rod connections; no approach at uniformity existed in the design of frames and running gear; bearings and valves and valve gear were often badly designed for the work to be done, while little intelligent attention had been bestowed upon the design of reciprocating parts with a view to controlling the disturbing forces imparted to the driving wheels. Millholland's work, extending over eighteen years on the Reading, was largely devoted to remedying the defects

of the crude locomotive. His work was on a level with that of George S. Griggs, Wilson Eddy, William Mason, Ross Winans and other engineers whose intelligent labors advanced the locomotive from a crude elemental machine to a well proportioned locomotive.

Millholland was the first designer to place the fire box of the locomotive above the frames, which was done on the Vera Cruz in 1857.

(To be continued.)

A move has been made by the German Society of Mechanical Engineers, which is well worthy of imitation on this side of the Atlantic. They have offered a

prize of 6,000 marks for a treatise on locomotive construction discussing the theoretical, mechanical and geometrical principles involved. Another prize is offered by the same society for a treatise on car trucks.

Mind your own business with your absolute heart and soul; but see that it is a good business first.—Ruskin.

Holland Sleeping Car on an Electric Railway.

A car of more than usual interest, called the "Theodore," was recently purchased from the Holland Palace Car Company by the Columbus, Newark & Zanesville Traction Company, and has been put in service between Columbus and Zanesville. In day time the car will accommodate 24 people, but at night when the berths have been made up, it has room for 20 persons.

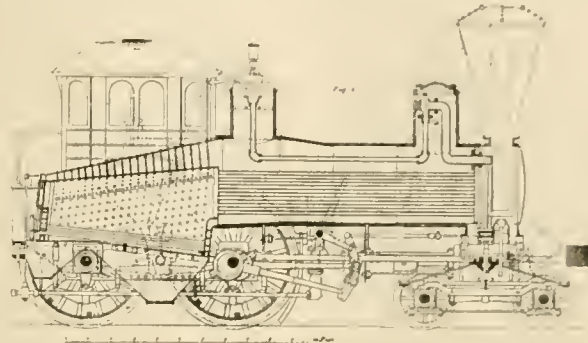

MILLHOLLAND'S ANTHRACITE PASSENGER ENGINE. FIG. 78.

When being used as a day car the passengers sit in swivel chairs, like those of an ordinary parlor car. When berths have to be made up, two of these seats combine to make one berth. There is an ingenious system of wooden shutters which come up through the floor and divide the car into compartments. There are five upper and five lower berths. Each berth is lighted with three incandescent lamps which can be turned on and off at pleasure by the person occupying the berth. Space has been left between the curtain which hangs down in front and the outer edge of the berth and this permits a person to stand erect when dressing, thus adding materially to his comfort.

The motors which drive the car are four in number and are 150 h.p. each, and a speed of 80 miles per hour has been made on the trial trip. The floor is specially designed to deaden the sound of the motors, having five distinct layers and a packing of 8 ins. of mineral wool. The car and both front and back vestibules are electrically heated.

The catalogue of the American Balanced Valve Company, of Jersey Shore, Pa., has just come to hand. It is devoted to the consideration of the American Semi-plug piston valve. This valve is so made that the packing is kept tight by the pressure of live steam and the rings fall away loosely when steam is shut off. This is said to greatly reduce wear and to do away with the necessity for relief and by-pass valves. The arrangement of the packing rings is very ingenious. Write to Mr. J. T. Wilson, president of the company, and ask for this booklet No. 22, which describes the semi-plug piston valve.

A Fast Lake Shore "Columbia."

The Lake Shore & Michigan Southern have on view at the St. Louis Fair a fast passenger engine of the Columbia type, which is part of the exhibit of the Vanderbilt lines. The engine was built at the Brooks works of the American Locomotive Company.

The cylinders are $20\frac{1}{2} \times 28$ ins. and the driving wheels are 80 ins. in diameter. The weight of the whole machine is 190,200 lbs., and the amount carried on the drivers is 142,700 lbs. The weights on the drivers and trailing trucks are very nearly alike. That on the engine truck is 22,800 lbs. and that on the trailing truck 24,700 lbs. The tractive effort of this engine is about 25,000 lbs. The engine is equipped with piston valves 11 ins. in diameter and with $5\frac{3}{8}$ ins. travel. Outside lap $1\frac{1}{4}$ ins. and lead in full gear $\frac{1}{8}$ in. The valve motion is direct, with transmission bar passing over the axle of the forward drivers. The distribution of weights is arranged so that the front pony truck and the forward driver are equalized together and the main and rear drivers and

suggests speed. The wheel arrangement and the spacing of the wheels is such as to give a very neat and clear cut, and even elegant appearance to the machine. A few of the principal dimensions follow:

General Dimensions—Weight engine and tender in working order, 320,200 lbs.; wheel base, driving, 14 ft. 0 in.; total, 31 ft. 10 ins.; total engine and tender, 57 ft. $3\frac{3}{4}$ ins.

Cylinders—Size of steam ports, $1\frac{1}{2}$ ins. \times $25\frac{1}{2}$ ins.; size of exhaust ports, 65 ins.; size of bridges, 3 ins.

Wheels, etc—Dia. and length of driving journals, 9 ins. dia. \times 12 ins.; dia. and length of main crank pin journals, $6\frac{1}{2}$ ins. dia. \times 6 ins.; dia. and length of side rod crank pin journals, $7\frac{1}{2}$ ins. dia. \times $4\frac{1}{2}$ ins.

Boiler—Thickness of plates in barrel and outside of fire box, $\frac{5}{8}$, $\frac{11}{16}$, $\frac{3}{4}$, $\frac{9}{16}$, $\frac{1}{2}$, $\frac{1}{2}$ in.; fire box, length, 85 ins.; width, 84 ins.; depth, front, $68\frac{1}{2}$ ins.; back, $68\frac{1}{2}$ ins.; plates, thickness, sides, $\frac{3}{8}$; back, $\frac{3}{8}$; crown, $\frac{3}{8}$; tube sheet, $\frac{1}{2}$ in.; water space, front, $4\frac{1}{2}$ ins.; sides, 4 ins.; back, 4 ins.

American Locomotives in Germany.

Some years ago a number of American locomotives were purchased for the Bavarian State Railways for the purpose

care bestowed upon them as upon the Bavarian locomotives, the American locomotives would prove less durable than those built in Bavaria. Indeed, many of the parts of construction have been found so simple and practical that they will be adopted in the construction of Bavarian locomotives.

Steam Turbines.

Turbine steam engines have been coming so much into service of late years for driving electric machinery and for small steamer power, that engineers have been expecting to see that type of engine used for ocean steamers; but it appears that the steam turbine is not yet developed sufficiently to push out the quadruple expansion engines now used on fast ocean liners. Rear Admiral Melville, U. S. N., who has been abroad studying the turbine engine problem, says:

"Turbines have not yet reached the stage of development which would warrant their use in battleships," said Admiral Melville. "Except for experi-

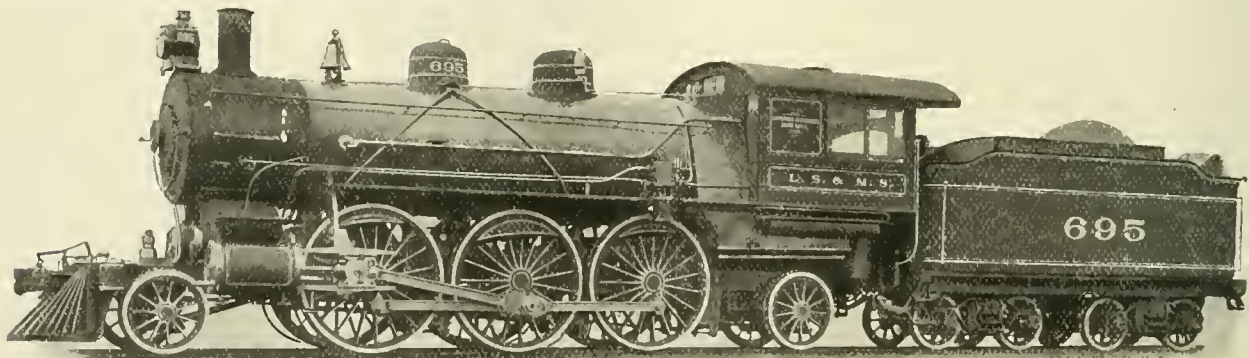

COLUMBIA TYPE FAST PASSENGER ENGINE FOR THE LAKE SHORE.

H. F. Ball, Superintendent of Motor Power.

American Locomotive Co., Builders.

the trailing truck are equalized together, all with overhung springs.

The boiler is radial stayed with wide fire box, with first and second courses slightly tapered toward the smoke box. The outside diameter of the latter course is 66 ins. and the inside diameter of the third or dome course is $71\frac{1}{2}$ ins. The pressure carried is 200 lbs. There is a fire brick arch in the fire box supported on four 3-in. water tubes and these tubes give 24 sq. ft. of heating surface. The fire box itself gives 160 sq. ft. and the tubes, which are 344 in number and 19 ft. $\frac{1}{2}$ in. long when added in, give 3,597 sq. ft. of heating surface in all. The grate area is 48.5 sq. ft. Two No. 11 Nathan injectors supply the boiler.

The tender has a 10-in. steel channel frame and the tank carries 6,000 U. S. gallons of water and 13 tons of coal. The tender trucks are of the arch bar type with I-beam bolsters. The tender weighs empty 57,180 lbs.

The general appearance of the engine

of comparison with those of German design and make. Reports have been current recently that experts had declared that the American locomotives could only last at best from eight to ten years, while the locomotives manufactured in Bavaria have stood service for thirty years, and that for these reasons, as well as because of frequent necessary repairs, the further use of American locomotives had been abandoned. Our Consul-General at Munich, Bavaria, Mr. James H. Worman, has been at pains to investigate these reports, and he declares that they are unauthorized and wholly groundless. The facts are that the locomotives which had been bought in order to study the American system of locomotive building have proven, because of their simplicity, their originality of construction, and their remarkable locomotion for fast and freight trains, most acceptable, especially as to durability and efficiency, and that up to this time nothing has been discovered to warrant the statement that, with the same

mental purposes I should oppose the building of turbines for naval vessels.

"The turbine is in its infancy. I found the whole of Europe alie to the problem, but engineers are not satisfied as to the claim of economy in coal and weight which is made for the new engine."

Several steamers having turbine engines are in use in the United States and they are very highly spoken of, particularly for the absence of vibration. That form of engine has so many good features that the defects that detract from its popularity are certain to be soon eliminated.

Ex-Senator Henry Cassaway Davis, who has been nominated for vice-president by the Democratic party was at one time a brake man on the Baltimore & Ohio Railroad. He was noted on the road as a man who went back the required distance when flagging was necessary for the protection of the train.

General Correspondence.

One of the "I Told You So" Men.

I once had the extreme "good fortune" to strike a job tool dressing in a shop in Illinois where locomotive repairs and new engines were the exclusive work done, and as I only had about 80 machinists, 30 boiler makers and floor men and round house men too numerous to mention, to keep track of and repair tools for, I certainly had my hands full, first, last and always.

There were some very difficult tools to make and among them a mushet cutting-off tool used on the piston ring lathe, and another used for facing off hubs of wheels used in the pilot trucks. Now, these two jobs cost me more time and worry than anything else I had to do, and as I always had the faculty of putting my wits and ingenuity to work to get out of hard work if possible (and a very good fault I have found it), I did some very tall thinking when everyone else was reclining on their downy couches, and the result was that I hatched out of my knowledge-box a couple of tools that worked a revolution in the two industries aforesaid, and at the same time came near being my undoing, for the foreman of the machine shop was one of those kind of fellows who did not want any improvements made by the small fry, and I seemed to very small potatoes in his eyes, and his own opinion of himself was about the size of the Alabama Iron Vulcan at the World's Fair, only he did not weigh so much, but his head was a great deal harder than Vulcan's was or ever will be.

A description of the lathe tool used up to my time was of mushet steel, $5/8 \times 1 \frac{1}{4} \times 10$ ins. long, and Fig. 1 gives a top view of it, and the difficulty lay in the fact that this extremely brittle steel had to be worked down from $5/8$ in. thick to $1/8$ in. and then turned at right angles, and if they would not break in the making they would surely break in the lathe when a heavy cut was taken or they struck a hard spot in the ring; so after I schemed out the new tool I asked the man running the lathe if a tool holder like Figs. 2 and 3 and a straight piece of mushet steel drawn like Figs. 4 and 5 would do the work as well if not better than the old style tool and he informed me there was one in his locker like that, but they could never get the steel to stand up to the work as it would continually break off. I asked him to let me see it and perhaps a change might help it. He brought it in and I saw at once where the trouble lay, as the slot A, Fig. 2, was far too small, and I told him I thought by enlarging the slot it would

work better by making it $3/8 \times 1 \frac{1}{4}$ ins., which I proceeded to do, and got the tool maker to run a tap in the set screw hole to clean it out and drew him out some pieces of mushet steel about 6 ins. long and he was ready for business.

He had already cut off eight rings with the new tool when his foreman came around and caught sight of the new tool and wanted to know where he got it, and was informed I was the instigator and construction engineer of the new time annihilator and he proceeded to show the foreman how the old or rather new thing worked, and explained that Father Time had closed up shop and left his scythe to be sold for old junk, as the new tool had discouraged him so, he thought it best to quit business and emigrate to some other planet.

The more this man said about the tool the hotter his foreman got and finally he ordered him to take the tool and holder out and throw them away, and then came in to my foreman and gave him a blowing

After things had simmered down and we were all back earning our noonday pile by the sweat of our brows and our lusty right arms, the lathe man's foreman came to him with a rather sheepish face and proceeded to square himself in the style:

"Now, John, I have been thinking for a long time about that tool and lost a good deal of sleep thinking how to make it work, and it made me pretty hot to see my ideas purloined out of my head like that by a little 2x4 runt of a tool dresser, and hereafter, when anything comes up like this just tell me before hand, and I'll fix it so we'll get the credit for such things, for we're entitled to it, for I have had this tool in mind a long time and don't see how that descendant of a pigmea ever thought of such a thing." After this relief to his feelings he walked off congratulating himself that his oratorical effort had thoroughly smoothed out all the rough places heaved up by his pigheadiness.

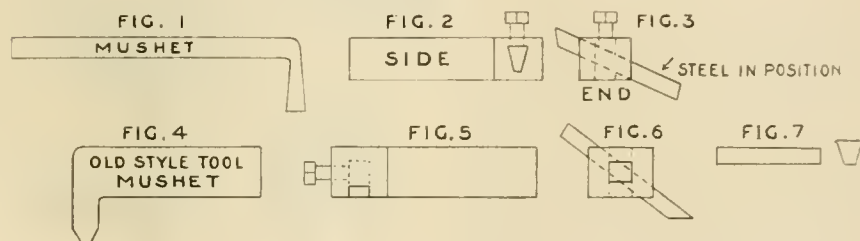

SOME OLD AND NEW TOOLS AND HOLDERS.

up, because, he claimed, I was interfering in his business and he ordered those tools to be made in the old way, and I had to make a couple forthwith, and when made the lathe man broke them both before he had cut off half a dozen rings, and then the lathe man got his back up and went to the general foreman and said he would quit there and then if he had to use the old tools, and then I was hauled up on the carpet to give my version of it, and explained that it was with the best intentions in the world that I had enlarged the slot and drawn the steel for the man. The general foreman told me I was paid to make tools as others wanted them and not as I wished to make them myself, and had a half smile on his face, and told the lathe man to use the new device if by so doing he could get out more and better work, and the lathe man started to tell him the tool had put Father Time out of commission, but remembering how this had caused one rumpus, he checked himself, and said he could do at least four times more work than formerly and was instructed to use it all the time if this was the case.

Now, as I had another device to save myself some work, I went ahead cautiously this time to gain my end, as the tool maker was a good friend of mine and would do anything to get ahead of his foreman. I enlisted him in my services by telling him what I wished to do, so he made a drawing of the new tool, for the boring mill and got the consent of the general foreman—while the machine shop foreman was off a couple of days—to have the tool made. Fig. 4 shows the old tool and Figs. 5 and 6 and 7 show the tool holder and mushet tool used in the new device.

The tool fitted snugly in the slot in the boring bar and was fed across the hub of the wheel as the latter revolved by a feed screw, and when the tool got out almost to its outer limit the strain was generally so great as to break the point or break the tool off in the slot and it kept me busy making them when the boring mill was running on this work.

The new tool holder as shown in Figs. 5 and 6 was made of mild steel and ground to size, then case hardened to stiffen it, and the tool proper consisted

of a piece of mushet steel drawn to 1 in. square, 6 ins. long, and it did the work admirably and was in full blast and doing a bargain sale business in facing wheels when our old friend, him of the Vulcanite head, came around to see if there was anything doing and noticed the new rival of the piston ring device throwing chips in all directions, for the man had speeded the machine up and was crowding her for all she was worth, for he wanted to see just what she would stand, as I told him he could take all the cut he wanted without fear of breaking that tool, but it seems he would not take my word for it, but wanted to be "sighted."

I had already put him "next" what to say when the foreman came around, and he told the foreman the toolmaker had it made for him, but the tool dresser had kicked like a Missouri mule in South Africa when they wanted him to make it for them.

He complimented the man on the way it was doing the work and proceeded to pat himself on the back and throw bouquets at himself and mud at me, as follows:

"I tell you, Jim, that sawed-off son of a dwarf is getting entirely too smart and consequential around this shebang and he will have to be taken down a peg or so, for I told him a month ago that a tool like that was what you needed here and told him he had better make one for you, but when it comes to the pinch he kicks and tries to get out of doing the work he is paid for. I will have to see the old man about him and have a change made on that fire, and if he was in my department I would have tied a can to him long ago and got some one that would do work without so much fuss and grumbling, but that's the way with those little fellows, they always think because they are small that they ought to be pitted and do less work than the ordinary man and get twice as much pay for doing it, and as for a head and brains, I never saw one yet that had enough brains to fill the skull of a new born babe, and you have to stand over such men whenever you want anything new made, for if you don't they will be sure to get it wrong and have to throw it in the scrap." He went up to the tool room and asked the toolmaker to give him his sketch of that boring mill tool that he had given him about two months ago and the toolmaker told him he had lost it after making a copy of it. I did not get much credit, but had less work to do thereafter.

T. Toor.

Laying Off Shoes and Wedges.

Referring to Percy's method of laying off shoes and wedges, as published in the August issue of RAILWAY AND LOCOMOTIVE ENGINEERING, I beg to criticize this method, inasmuch as in many instances it would not give correct results. First,

in squaring the jaws by the use of cylinder lines and the straight edge it will be found that upon the larger percentage of engines, one frame will be ahead or back of the opposite one, and in a case of this kind either one frame or the other is taken to be in the right location, or the difference between the two sides is divided, and the error is overcome in the lengthening or shortening of the main rod. This method, as described by Mr. Percy, is the one generally in use to find the main centers, but further than this I must disagree with him as to the accuracy of his idea. We will take, for an instance, that one of the frames has been broken and welded together again prior to the engine's shopping in question, and that the break occurred in top and bottom rail between main jaw and the next jaw back on left side. With all due credit to the blacksmith shop, will suppose that they did the job in the customary manner, and the frame when cool showed to be either $\frac{1}{8}$ in. too long or too short between center—this is generally conceded to be a close job for all practical purposes, and can be overcome

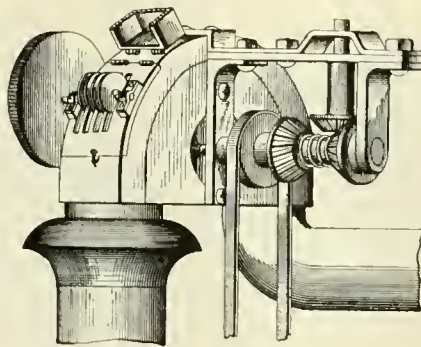

THE LATEST PATENTED LOCOMOTIVE SPARK ARRESTER.

by the machinist on the erecting floor. According to the method mentioned, only the main jaws would be squared, neither would the tram be used to prove correctness. The result would be that the centers on left side would be $\frac{1}{8}$ in. out one way or the other. This would be serious in this day of solid side rods, and would be very incorrect in any event.

Of course it is understood that the wheels are trammed after being placed under engine, and if any error developed could be easily remedied by changing the shoe and wedge liners or replacing same, but any method which requires after adjustment should not, I believe, be adopted as a standard for future operations.

Another bad feature is the method of obtaining centers at bottoms of shoes and wedges, as it is quite apt to be incorrect. Those who have found centers by the use of long arcs scribed from two points in close proximity, know that the exact point of intersection is quite difficult to determine, especially when the

light is poor, as it generally is in the region of main frames and shoes and wedges.

E. O. PALMER.

Sayre, Pa.

Neglecting the Stitch.

"A stitch in time saves nine," and "Let well enough alone," are two maxims that are familiar to many. Each, of course, express a measure of wisdom, but there are conditions met in the experience of the engineer that makes the matter of choice between them a knotty problem. There is a fundamental law governing the acts of all good railroad men which says, "In case of doubt take the safe side," and the safest side in most cases, all things considered, seems to be the side that calls for the least immediate present delay, regardless of the possible immediate future results. Not that the engineers as a class are shiftless or reckless, but because that unremitting presence of "Get There" is always uppermost in his mind, and between a positive delay and a possible one, he most frequently chooses the latter by leaving things that are well enough (?) alone.

By following the latter course there is less risk to one's reputation sometimes. This fact was illustrated to me some years ago when I was firing.

We were going along on time with a passenger train, when suddenly the old Danforth & Cooke commenced to go lame. I glanced over at Dan, who appeared to not notice it, and was about to call his attention to the matter when, with a wave of the hand and a look that could not be mistaken, I was made to understand that it was not my move, so I continued to follow my hand with the scoop, making no further outward sign of interest in the lameness of the 49.

However, we went but a few miles further when we came to a point in the road where, to use a pet expression of Dan's, he had to "widen on her," and just as soon as he did something happened. After stopping we found the left forward cylinder head blown out. We fixed her up, proceeded with engine on one side and brought the train in, as Dan remarked, "a little late, but with our reputations untarnished."

I did not understand his reference to our reputations at that time, nor could I reason out why he did not stop and fix the 49 when she first went lame, nor did I dare to ask him until after I was promoted about a year later. He explained as follows:

"Had we stopped that day when the 49 commenced to limp we would be there yet trying to find out what was the matter with her. We would be the laughing stock of the men, particularly of those who knew even less than ourselves, besides getting — from the officers. The engine was doing well enough until she blew out the head, and then our work was

cut out for us, and we knew what to do. A stitch in time is all right providing one knows where to put the stitch."

T. P. WHELAN.

[We consider the action described pure recklessness. It was the bounden duty of Dan to stop and look for the place where the stitch was needed.—Ed.]

Lining up Shoes and Wedges.

This illustration will no doubt afford food for thought, as it dispenses with the ordinary and common practice of lining up shoes and wedges by the application of sheet steel, which is made secure by the means of rivets and which is a slow and expensive operation. The effect of the rivet protruding through the liner is very detrimental to the face of the pedestal jaw, and necessitates the filing or facing of the same on locomotives undergoing general repairs.

It is here proposed that a frame be made of cast iron, the inner faces of which are planed to 90 degrees, leaving an offset at the bottom of the upright part for the purpose of carrying the weight of the wedge and sufficiently high to allow the flanges of the wedge to clear the base of the bevel or angle attachment.

The face of the wedge is drawn up against the top arm of the frame by the means of a yoke, as shown. The size of the box is then taken and also the angle of the jaw, after which the angle attachment is set by the adjustment of the thumb screw to correspond to the angle of the pedestal jaw. Adjust the parts by the means of the two thumb screws, leaving a space to be filled with a good grade of tough, hard Babbitt metal. Provision should be made by drilling two 1-in. holes through the face of the wedge and countersunk on either side for the purpose of retaining the babbitt.

J. E. OSMER.

Northwestern Elevated Ry., Chicago.

Tests of Locomotive Boilers.

A somewhat tardy reading of your editorial comments in your August issue, on "Investigating Locomotive Boilers," leaves the impression that you have in some way obtained an entirely erroneous idea of the actual wording, the intent and the scope of the resolution adopted at the last Master Mechanics' convention regarding the use of a special fund for conducting experiments and tests in connection with locomotive boilers. It is not usual for your editorials to make wrong assumptions, and I desire to correct the impression that the money named in the resolution is for "investigating things that could not be altered."

If the wording of the resolution, and the remarks preliminary to the resolution had been carefully read and understood as intended, I doubt if your editorial would

have contained the quite scathing remarks set forth in the last paragraph. So that a seeming error may be corrected, I quote the resolution passed, and the introductory remarks preceding it:

"I think the discussions at this convention, as at several previous conventions, on this subject, have clearly shown the great importance that the members assign to the subject of proper boiler design. The discussions have brought out the fact that there is a great lack of reliable data that might be considered in a way official, regarding the proper proportions of grate surface, of length of tubes, and of many other features in that same line. I believe it is desirable for this organization, as it stands for advanced methods in locomotive construction and design, to obtain that data. It may not be feasible, perhaps, to take money for that purpose directly from our funds. I believe, though, that there is such a general interest in the subject, that there are many railroad companies, possibly some individuals, and

suggested by the "Boiler Design" committee regarding circulation and the temperatures at the side sheets.

The report of the committee was rather disappointing, as showing a tendency to devote time and effort to points of minor value, overlooking seemingly, points of importance on which there was a great diversity of opinion, but no reliable data. In order to get future efforts made along more practical lines and to enable a new and differently constituted committee to be appointed to take the subject in hand, the above quoted resolution was offered and carried.

The absurdly great variation in common practice, and the clearly expressed lack of satisfactory information in recent years as to the economically proper proportions of heating surface, grate surface and length of tubes for the present types of mammoth locomotive boilers, would seem to fully justify some official recognition, and definite investigation and solution by the Master Mechanics' Association.

A. M. WAITT.

Yonkers, N. Y.

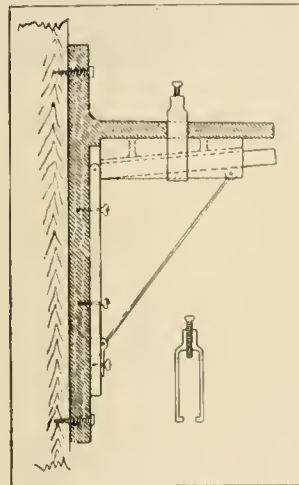

APPLIANCE FOR LINING UP SHOES AND WEDGES.

also some of the locomotive building companies that would be glad to join in getting official data and facts that could go down for many years to serve as a basis for proper boiler design. In view of that I would move the adoption of the resolution which I will read:

"Resolved, That the executive committee is hereby authorized and empowered to promote and direct the raising and expenditure of a special fund not exceeding \$5,000, to be used under the direction of a *special committee* for conducting a careful series of experiments and tests concerning the *values of varying proportions and dimensions of heating surface, grate surface* and such other *important features* of boiler design as may in the opinion of the committee be found desirable."

It will be seen at a glance that the resolution gives no reference to, nor had the one who offered it any thought of expending money to carry out tests on lines

To Make Railway Accidents Impossible.

In *Locomotive Engineering*, of September, there is an article on railway accidents in which the statement is made that railway companies are exhausting the capabilities of invention in equipping their rolling stock and their stations with safety appliances. That statement is only partly true, for there are thousands of railroad stations that have no safeguards worth mentioning, and the railroad companies that have introduced the best safety appliances in use are behind the requirements that the great growth of the traffic has demanded.

I should like to direct the railroad companies that are "exhausting the capabilities of invention" to investigate what the Underground Railway people in New York are doing to prevent accidents. They are equipping the tracks with the best protection signal system any railroad has ever had in use. The engineers who have devised this system of protection have done everything that human ingenuity could devise to provide against human fallibility, that source of disaster that has received so little consideration. Every block is protected by duplicate electric signals, and besides there is at the beginning of each block an automatic device that stops any train attempting to pass a danger signal, and this stop is effected without the volition of the motor-man. The blocking is absolute and there must always be a free block between two trains.

If surface railroad companies would do more to provide against human fallibility they would save much life, prevent untold suffering and avoid expensive wrecks that have such a depressing effect upon the dividends of many com-

panies. If they could only be prevailed upon to incur the first cost, railroad companies would find perfected safety appliances the most profitable kind of outlay.

JAMES R. BEATTIE.

Brooklyn, N. Y.

Front End Troubles.

Is not the high saddle responsible for a great many of the front end troubles that modern locomotives are heir to?

The fore and aft expansion will move in the line of least resistance. The line of least resistance should be aft; but to the writer's mind, keeping in view the unbraced high saddle, this part of the engine comes in for a lot of grief. When we consider the enormous weight of the back end of the boiler, the friction of its bearings and the many attachments, all tending to prevent any rear movement due to fore and aft expansion, does it not look reasonable that the high saddle is too weak as at present designed? Do I hear some one say the

position of the studs. If cold pressed nuts are used on the boiler studs, the thread should be well coated with graphite or a brouze nut used, so that in unscrewing, the nut will start the stud out of the sheet. It is advisable in fitting the studs in the sheet that the thread be just long enough to allow the end of the stud to come flush with the inside of the sheet. When the end of the stud projects through far enough to allow scale to form on the thread, it destroys the thread in the sheet when there is occasion to take the stud out. The crack, A, in Fig. 2, is something peculiar to a certain build of engines; this crack extends from the saddle through the exhaust port, and through the steam chest seat, to such an extent that a band around the edge of the steam chest seat is required. No, I do not know what causes the break; whether its contraction in the casting or one of the high saddle troubles. These brackets should be steel castings if possible, as they would be light and strong. The shape is not arbitrary.

quence to receive attention in any precise discussion of the subject. It would seem that there is an "if" in connection with the statement that the turning moments of the compound are more uniform than those of the simple. The if practically amounts to this. If the simple engine were to cut off as late as does the compound, there would be no difference in the turning moments, or if the simple engine was working very hard *dragging* a train up a grade, I cannot see but that the turning moments are as uniform as they can possibly be, as any increase of cut-off beyond $\frac{1}{2}$ stroke will result in a quite uniform motion. Another feature to be considered in this connection is that the simple engine of the same maximum capacity, as the four cylinder compound, has a larger cylinder, and the maximum horse power or tractive force is fully as great as that of the four cylinder engine, but the high pressure cylinders of latter being smaller, they must necessarily cut off later in the stroke to obtain the same power, or one might say, the same M. E. P., and at the same time give the low pressure cylinders something to do their work with. But this uniform turning moment does not necessarily belong to four cylinder engines only, as the high pressure cylinder of the cross compound will have to cut off as late as that of the four cylinder balanced compound. But the balancing effect of the latter is the chief point in its favor; in fact, the only one, and this is, to be sure, a very important point. In looking over the descriptions of the various types of four cylinder balanced engines, I can but think that the de Glehn is the best arrangement, in that it divides the work between two axles instead of putting all the work on one axle, as the imitators of this type have done. With the former arrangement, should anything happen one axle, or pair of wheels, we still have the other pair to do business with. The torsional stress on the main axle, as arranged in this country, is considerable, and I would suggest the arrangement of the cranks, as follows: Crank pin in right wheel No. 1, followed by the crank axle, No. 2, set at 90° to No. 1. The left crank axle, No. 3, set at 90° , with No. 2, and the crank pin in left wheel at 90° with No. 3. With this arrangement Nos. 1 and 3 are in balance, as are Nos. 2 and 4. This distributes the work on both ends of the axle, and the balancing feature is still preserved. To be sure the engine will then need to be arranged on the receiver system, instead of on the "Woolf" system, which need not be a serious objection, as the former system is used on the Continent.

As regards the valve gear of the various types, all the foreign engines have a separate valve and gear for the high and low pressure cylinders. The original de Glehn, the Von Borries, and the

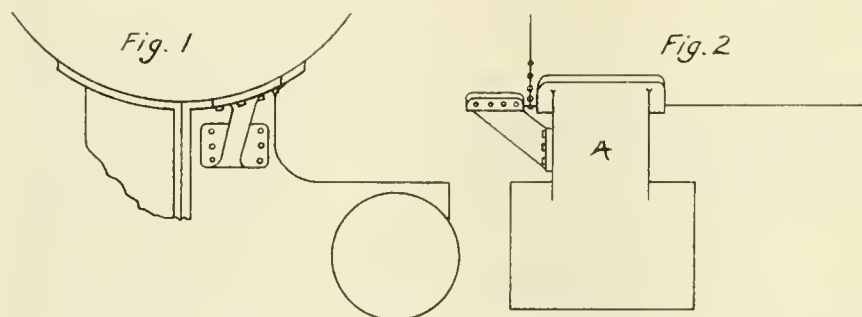

PROPOSED STAY FOR ENGINES WITH DEEP CYLINDER SADDLES

front braces provide a support? My dear brother, some engines have no front braces; others have them so nearly verticle that they merely tie the smoke arch and frame together. It is safe to say that these front braces cut a very poor figure in supporting the saddle. Emergency applications of the air brakes, and in particular in drifting down grade, or in making service stops, coupling to a train, having the helper back up with a thump, to make a front end coupling, and the thousand and one movements and jars that cause the water to surge back and forth in the boiler; sudden jars to the running gear that do not overcome the inertia of the boiler must be taken care of, in part by the saddle. To meet these front end troubles, I would suggest the brackets shown in Figs. 1 and 2. These brackets should have a good bearing, both on saddle and boiler, there being no room to make driving fits in that part between saddle and bracket; tap bolts with a good fit in the body could be used. Where the bracket is secured to the boiler, the holes through the bracket or pad should be loose, so the bracket can be slipped over the studs easily, on account of the radial

I offer these suggestions as a means of strengthening the saddle.

W. DE SANNO.

San Francisco, Cal.

The Four Cylinder Balanced Compound Locomotive.

Following the description of the Santa Fe four cylinder compound locomotive in one of the technical papers a short time ago was quite a discussion, some writers claiming that the turning moments of this class of engine were nearly as uniform as those of an electric motor, and others claiming the turning moments were no more uniform than those of the simple engine. The matter was finally referred to Professor Goss, of the Purdue University, who said that, as far as the crank arrangement was concerned, the turning moments were no more uniform than those of the simple engine, and, in conclusion, the Professor says that an analysis of curves, representing the tangential forces of the two types of engines (simple and compound), will probably show that the difference in the turning moments are not great, but they are, nevertheless, of sufficient conse-

Webb used on the London and North-Western, are all provided with valve gears as described, of which the "Webb" is doubtless the most simple. There is no doubt but that either of these types will give a better steam distribution than the "Vaueclain" single valve system, and a study of the indicator diagrams, taken from this latter type and published in the *Railroad Gazette* of January 22, 1904, will be interesting, and I can but think that the "Webb" system, with its separate valves, would be more economical to maintain than the Vaueclain. As before stated, it is the most simple and ingenious of the foreign engines, the reversing of both valves being accomplished by the single reverse lever, and one gear operating both valves, the "Joy" valve gear being employed.

In connection with the description of the "Webb" four cylinder engine, here is an illustration of a 0-8-0 freight engine, designed on the same system. It is notable that in the description of these two types (the Von Borries and Webb), by a noted authority on mechanical matters, Mr. Geo. L. Fowler, there are no claims made that the turning moments are any more uniform than those of the simple engine. It is very singular that so eminent an authority overlooked this important feature; and also that he should express himself as follows: "In spite of the fact that the cranks (speaking of the Von Borries engine) are set at an angle of 180° with each other, the starting is effected smoothly, and without any pounding on the crank pins, whatever their position may be." One writer in the *Railroad Gazette* held that the cranks of the Vaueclain-de Glehn engine were set at 90° to each other, and the crank arrangement is the same as that of the engines described by Mr Fowler. Summing it all up, it would seem that the only point in which the de Glehn and its modifications excel the other compounds, is in its balancing feature. This is to be sure, a very important feature, and that the four cylinder balanced compound has great future before it no one will question.

J. V. N. CHENEY.

Portland, Me.

The Reward of Virtue.

He was once a poor and humble section hand,
 But the moments that his comrades gave to play
 He put in at useful, patient study and
 He writes "president" behind his name to-day.
 Is he not a greater man than is the one
 Whose birth alone has served to place him high?
 But his wife and daughter blush for him;
 his son,
 When other people praise him, wonders why.
 S. E. KISER, in *Chicago Record-Herald*.

Handy Shop Kink.

A very neat and compact time and labor saving device may be seen in the St. Johnsbury roundhouse on the Boston & Maine Railroad. Briefly stated it is nothing more than a portable rotary

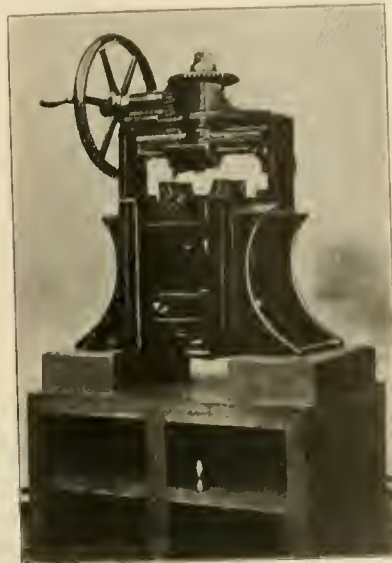

ROTARY PLANER FOR ROD BRASSES.

planer for rod brasses and is made out of odds and ends.

Our illustration shows the machine complete. It consists of two upright columns about 15 ins. wide and 20 ins. high and connected by a yoke which supports the planer. The columns are grooved to permit of either an upward or downward movement of the face plate, which is controlled by a screw feed and lock. As the planer revolves it engages the star feed with the dowel pin secured to the yoke in the same manner that valve facing machines do. The face plate is provided with a suitable clamp to accommodate one or two rod brasses. All of the various parts which go to make up the complete machine have seen previous service in some other capacity. The gear wheels were taken from an old governor and the large wheel did service on an old letter press. Where there is a many stalled roundhouse a portable truck is preferable to the bench shown in the illustration as the planer can be then easily transported and placed near the work to be done. There isn't any opportunity for mistakes with this machine that there is with the old and unsatisfactory chisel and file method in the hands of an inexperienced operator. The machine, the design of which originated in the fertile brain of Mr. John Cleary Gun, foreman of the Lyndonville, Vt., shops, B. & M. system, has already proved its value and has been placed in several roundhouses on the B. & M. There is

no patent on the same and any road is at liberty to construct one like it

J. A. BAKER

A New Boring Tool.

The accompanying cut illustrates a new boring tool recently designed and patented by the writer.

Fig. 1 shows the tool, which is of the micrometer pattern, fitted to the spindle of the boring mill and ready for boring out the ear wheel on the machine. As will be seen by Fig. 2, the tool is made up of four steel cutters, located diametrically opposite, and adjusted to bore the hole large or small by the turning of the lower collar which contains the gradation marks. This collar is held in place by the upper collar after the adjustment of the tools has been made. The movement of one nut locks all cutters, making them as rigid as a solid head, insuring the boring of a true hole. One set of cutters will bore from two thousand to three thousand wheels.

Fig. 2 also shows the details of the tools, these tools being very simple and made of ordinary steel and having a life of several months or about 2,500 wheels. As will be seen, the tools are held in the holding head by set screws, but once these tools are put in place and fixed by the set screws, there is no further adjustment of the tools until they are removed to apply larger wheel cutters to bore for the next sized wheel seat, say, from 4x7 ins to 5 1/4x8 ins. Cutters can be sharpened without changing the adjustment.

Fig. 3 shows this micrometer principle



FIG. 2. MICROMETER TOOL FOR BORING MACHINE.

adapted to the cutter or boring bar for an ordinary lathe, or drill press, and is essentially the same as the tool for the boring bar of the boring mill.

The employment of this tool does away with a great amount of calipering and

fitting of the axle to the wheel. The axle is first calipered with the micrometer tool, which micrometer tool is in turn associated with the micrometer cutting bar and the cut started and run through. In other words, when the size of the axle is once known, the upper collar (Fig. 2) is

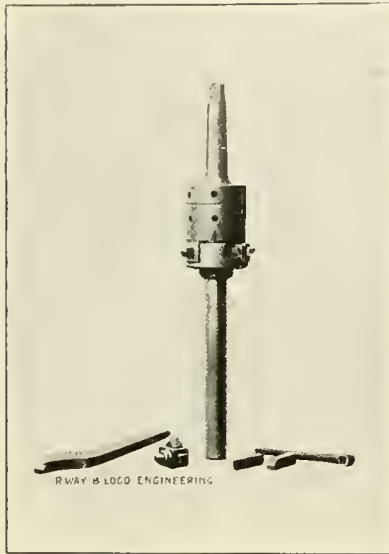

FIG. 3. MICROMETER BORING BAR FOR LATHE.

loosened and the lower collar turned around a sufficient number of times to bring the corresponding mark on the collar to that on the micrometer caliper used on the axle, and then $12/1000$ of an inch is allowed to make a tight fit between the axle and the wheel.

With this tool the work of boring out car wheels is much simplified, and a larger number of wheels bored out each day. One skilled laborer has turned out with ease as many as fifty car wheels per day of ten hours, and save all loss of axles from reduced wheel seats.

WILLIAM POHLMAN,

Shop Foreman, N. Y., O. & W. R. R.
Middletown, N. Y.

Speed of Wing Flyers.

According to the *St. Joseph News*, William W. Murphy, a locomotive engineer on the Burlington, has been making a study of the flight of birds and insects, the habit of many of the flying species, of flying beside the engine, giving him many opportunities of noting the speed made.

He finds that a chicken hawk and a crow can make twenty-five miles an hour. A turkey buzzard flies at the rate of twenty-one miles an hour. The pigeon is one of the fastest birds in the United States. It makes a speed of forty-six miles an hour with ease. When chased by an eagle it can beat the Burlington's St. Louis express. The wild duck is traveling at the rate of forty-four miles an hour while the hunter is pumping the

contents of a repeating gun at it. The blackbird, robin, dove and other small birds travel at a speed of thirty-eight miles an hour. The humming bird can and does excel a speed of a mile a minute. Murphy says that a humming bee the other day flew in and out of his cab window while he was going at the rate of sixty-three miles an hour. The performance lasted while the engine traveled a half mile.

Recently at the McKees Rocks shops of the Pittsburg & Lake Erie Railroad, the erecting shop record was broken. A boiler was sent into the erecting shop in the morning and placed upon the frames and cylinder saddle, and in 8 hours and 45 minutes later the finished engine was ready for the painters. The painters took 1 hour and 45 minutes to do their work, making a total of $10\frac{1}{2}$ hours from the time erecting shop work was begun un-

receive visits from inventive people who have an idea that they want help to work out into a claim for a patent. Mr. Henderson will be the best kind of adviser for such people.

The Seamless Steel Tubes Co., of Detroit, Mich., has recently been reorganized and renamed, and will, in future, be known as the Detroit Seamless Steel Tubes Company. This company makes a specialty of cold drawn seamless steel locomotives flues and stationary boiler tubes, which are rapidly growing in favor; and the seamless flue is fast becoming standard on the railroads of the United States. Plans are now being prepared for large additions to their plant to meet the increasing demand for their product.

An inventive Australian, who thinks he has developed a plan for making steel

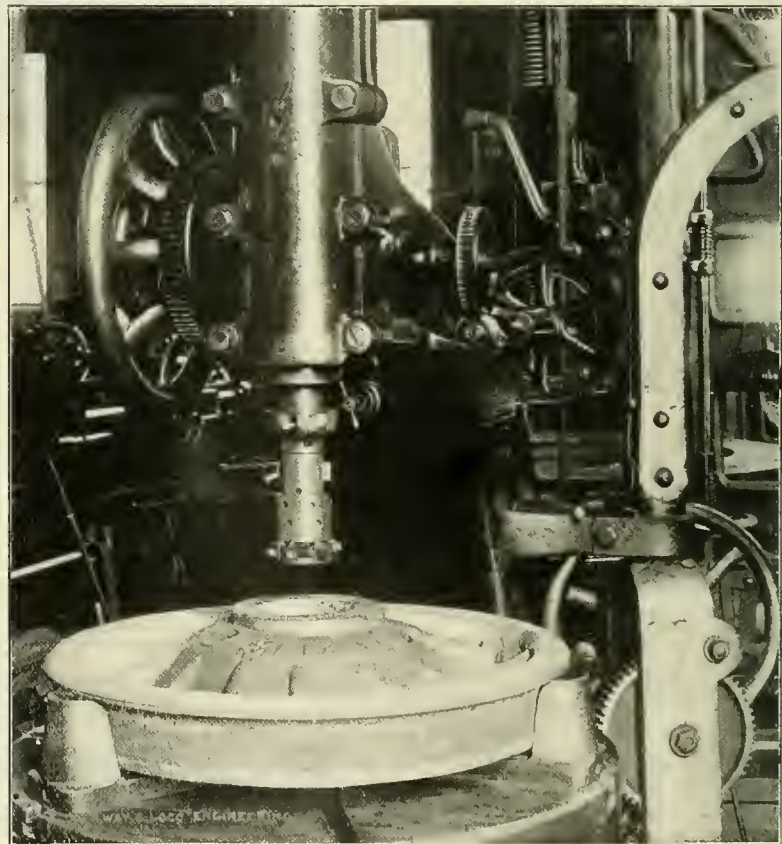

FIG. 1. A NEW BORING TOOL.

til it was finished. The McKees Rocks people are justly proud of their speed. Friendly rivalry between two well trained gangs was the cause of this burst of speed.

An office has been opened at 20 West 34th street, New York, by Mr. G. R. Henderson, the well known railroad mechanical engineer. Mr. Henderson will carry on a general business as consulting engineer with railroad appliances and equipment as a specialty. We frequently

direct from iron ore, wants the government to take up the process and make \$10 a ton on the product turned out. The curious thing about the situation, like that in regard to the electric smelting of iron which the Canadian Government is spending money over, is that men who are in the business and are willing to put out millions in improving their plants, do not seem to think it worth while to bother about the new schemes. It looks as if they were designed for governments to handle.

An Underground Instruction Car.

The Interborough Rapid Transit Company, of New York, in carrying out the wise educational policy inaugurated by Mr. Frank Hedley, the general superintendent of the road, have equipped an instruction car for the Subway Division somewhat similar to the instruction car used on their Manhattan Railway Division, which latter was illustrated



INSTRUCTION CAR—INTERBOROUGH RAPID TRANSIT CO.

and described in the January, 1904, issue of RAILWAY AND LOCOMOTIVE ENGINEERING.

The school car here illustrated is one of the copper covered subway cars, and the equipment has been installed by Mr. J. S. Doyle, master mechanic of the electrical department of the Manhattan Division. The car is equipped with brake apparatus for six cars, and by an increase of train pipe area in the car, the same volume of air as the six car train takes is used in the shorter but bigger pipe. The instruction pump, if we may so call it, does the same work in making a "stationary" stop for the class, as it would do in actual service. The brake cylinders are 12 ins. diameter and Westinghouse quick action triple valves are used.

There is, of course, a motorman's brake valve and a sectional model of the same, and there is a combined auxiliary and brake cylinder so arranged as to show the interior of each.

A tandem triple valve, in section, is attached to an operating triple. There is also a purposely ill treated triple valve which can be made to develop leaks and failures, so as to show the learners what actually happens with similar conditions in service.

Near one end of the car is an air operated pair of couplers with various styles of links, which shows how couplings are made. A contact shoe and piece of third rail, charged as on the road, is used to show how to safely insulate a broken or defective contact shoe.

The electrical equipment is most complete, contactors, circuit breakers, reverse

current mechanism, fuses and switches are all in evidence. The master controller with operating handle and emergency brake button, is in place with casing removed. There is an ingenious device placed above it by which the acceleration of the train is practically kept uniform and is not affected by a sudden or jerky movement of the controller handle by the man in charge. On level track about 12 seconds is required to start the train and get it up to maximum speed, even if the controller handle should have been spun round from zero to full position in a fraction of that time. This governing relay safeguards against overspeeding of trains, and automatically and evenly increases the speed from zero up to maximum.

The master controller has a handle familiar to those who have seen the Manhattan Elevated equipment. It has a broad button or knob on top of the handle, and this button must be pressed down before the handle can be moved. The button can be depressed by almost the weight of the hand, the resistance being a weak

these fingers the current entering the controller must pass, and the release of the button on the controller handle allows the contact fingers to snap sharply to the free position and instantly cuts off the electric current to the whole train.

A new function has been added to work of this handle button. Not only does its release cut off the flow of current to the cars, but by a most ingenious contrivance it applies the train brake in the emergency. The release of the button will apply the brake even if the train be at a standstill, and the only escape from this state of affairs is by putting the "reverse current" handle in the neutral position, in which case the controller handle cannot be moved and the car cannot be started.

An advantage which this style of handle and push button possesses is that greater attention to his duties is required to be given by the motorman, as the thoughtless relaxing of the hand which drives the train, will cause a sudden and violent stop to be made. In case the motorman



INTERIOR OF NEW YORK SUBWAY INSTRUCTION CAR.
Courtesy of the N. Y. Globe.

coil spring which does not require much muscular exertion to hold it down. The button or knob is called in the Interborough shops by such startling names as the "heart failure button" or the "dead man's handle."

The knob or button, whatever be its official name, performs a most important function and is a safety appliance of the highest order. Pressure on this button carries it down one-half an inch, and it may even rise up $\frac{3}{8}$ in. without producing any effect. Pushing it fully down brings into play two auxiliary contact fingers which are normally held out of service by a strong coil spring. Through

faints; is overcome from any cause, the same quick stop is automatically made, in the interest of public safety.

One other aspect of this "safety stop" button, if we may so call it, is that in case of emergency where the shortest possible stop is imperatively demanded, to save life, the motorman may have the satisfaction of knowing that he has fulfilled his duty and has done his very utmost, if he simply lets go the handle, the instant that dire trouble looms ahead. To sum all this up in a sentence, one may venture to readapt the well known kodak line, "You release the button, and a powerfully operated mechanism does the rest."

Expensive Conflict of Authority.

BY SHANDY MAGUIRE.

What an enjoyable time the rank and file of a roundhouse have listening to a pitched battle of the tongues of two petty bosses! "The winks and finger ends are notice taking" in dead earnest when the fun is going on. Terry Bennett, the roundhouse foreman, and Jim Deegan, the roadmaster, often limbered up their jawing tacks and went at it, regardless of spectators. It was a drawn battle for years between them; a regular give and take, and a resolve to have at it again.

After many a bloodless contest and fluent exchange of devil-may-care expressions, after exhausting the Christian calendar to swear by all the saints contained therein, then digging up from the chambers of the brain a score or two of pagan gods which had laid dormant since the far away days of spooning, to add to the list of oaths, Bennett was declared victor over Deegan at last, and this is the way the battle was fought and won:

cite coal burning type. When the slides would be opened, out would go the red hot coals onto the ties, and so long as any part of them remained to ignite, up would go the flames for a distance of 60 of them, to not only furnish a bonfire for the numerous kids who were there to pick the cinders, but also to throw light on them pitching into each other with the dukers for encroaching on each other's preserves.

Every little while, *if he had time*, Deegan would run in the work train and load up the ashes that Kelly had thrown alongside the track. At such times of ashes loading Deegan claimed to be sole lord and master of the right to the road. The water tub being on the turntable end of it, all the shifting engines and extras had to abide his sweet pleasure to move, and let them get water, for there he would remain until the ashes were loaded, in defiance of yard master to get him out of the way, his only excuse being, "I have 30 min. here, and I'll see you danged before I'll let thim sit down idle until

with bowed head, resting his body upon the handle of his shovel, he'd silently grin and bear it, knowing that Bennett would throw a kind word at him when Deegan would go out of the yard, for salve to soothe his lambasted mind—just what Jim wanted.

One recent November, Deegan left a clean ash track. Kelly supposed that when three or four cars had accumulated he would come after them, and consequently he did not use unnecessary muscle throwing them very far from the wheel track. "The best laid schemes of mice and men gang aft a-gley," Kelly found out to his cost; for the winter set in with a vengeance, and the snow, which fell upon the top of the ash pile, became ice in a short time, making a breastwork which he was unable to throw over. It took but a little while until the cylinders were plowing their way on each side, cylinder cocks were being knocked out, brake rods displaced and pilots either driven under the front beam or cockbilled, like a yearling pig going to battle, according to whether the engine was running ahead or backing, as the case might be.

Soon the severity of the weather necessitated the snow plow being put into service, to keep the road open. This was what Bennett was awaiting. He laid low, exulting in the thought of what he anticipated would happen—and it did.

The plow was ordered out one morning by Deegan with as much dignity as if he were the real admiral of the Atlantic Squadron, ordering the same into action. The "limited" was scheduled to leave at 7.40 A. M. Its time was sharp, its connections continental; and its coaches were loaded with passengers. The plow had to be turned before going out. The man in charge of it coupled on and told his engineer to give it to her, meaning to take a run, so as not to stall on the wheel track. He did, indeed; he "gave it to her" in royal style. The banks were sloping solid to the rail. The plow having a keyed center pin, and it being gauged to 2½ ins. above the rails, did not have clearance, and the result was it ran up the frozen slope of ashes and came as near gaining the top, to take a survey of surroundings as any plow could do that had spirit enough to resent the attempt being made on it to throw blue ice and ashes, instead of snow.

"Be jabers, but the fun'll soon commence," said Kelly, when he saw the condition of his pit at 7 A. M. Bennett soon joined Jim, and gave him a mild roast for not keeping the ashes further back.

"What dy ye take me for—a conveyor? I threw it three times distant, instead of one. You should have made Deegan draw it away whin there was two car loads. To the devil with ye and yer butcherin' job; they're payin 20 cints an hour to dagoes to shovel snow, and I'm gettin' but 12½ to shovel ashes and have me



APPLICANTS FOR EMPLOYMENT ON THE NEW YORK SUBWAY—
INTERBOROUGH RAPID TRANSIT CO.
Courtesy of the N. Y. Globe.

The track leading to the turntable, known the "the wheel track," from where it left the main track to the table, was 325 feet long. Upon it all the fires of all the engines were cleaned or dumped red and roasting on to Georgia pine ties; then, when the cinders cooled sufficiently for shoveling, Jim Kelly, the manipulator of the shovel, gathered them up and threw them just as far from the wheel track as a don't-give-a-damn fling of his arms sent them, and none too far at best. The "pit," as it was called, was a fit companion for the table, which dated back to the day that Noah launched the ark. Many and many a time prayers were said by the unfortunates revolving it, light or loaded, but they were left handed ones, as they prayed with their heads bent down upon their breasts, and keeping up a lockstep pushing. It was the unalterable custom of the place to dump ash pans with a bit of a run, so as to get away from all the ashes one could. The engines were of the anthra-

I am ready to get out of the bloody yard."

Deegan had a pull with the general super, so his ultimatum was respected. To the everlasting credit of Jim Kelly, be it said, that between Terry Bennett and Deegan formed a sort of a breakwater for the two to batter against, and he always came up smiling before being counted out. In expectation of Deegan coming to draw away the ashes when they'd amount to a car or two, he'd only throw them a couple of feet from the rails, on each side. If they weren't taken away at the proper time, they'd roll back to where they came from, almost, to the detriment of brake connections, cylinder rods, cocks and cylinder jackets; then Terry's tongue would play a quickstep upon Kelly's head. If they were unusually scattered about, Jim was not given the go-by when Deegan came after them by any means, and meekly and lowly, in a spirit of calm resignation, apparently, and

carcase lambasted by yourself and Jim Deegan." With that he fired his shovel into the center of the track, picked up his coat and scooted. Terry grinned, knowing he'd come back faster than he went.

The train dispatcher notified the super that No. 621 was yet standing at the station, waiting for the plow to run ahead of it, stating that the plow was derailed on the wheel track, and from report, it was likely to take a couple of hours to get it on the track again and turned. The super gave orders to let a shifting engine help 621 out of the yard, and endeavor to get through if among the possibilities. Terry gave a suppressed grin and said nothing when he heard of it.

Under the orders of Deegan, 50 miles away, the section boss got to work to put on the plow. This he succeeded in doing, and when pushing it towards the table, off it went again. The boss and his men went at it again, and were doing all in their power intelligently, until a telegram was handed to him from Deegan, to explain why he didn't get the plow out of the yard on time. "Tell him to come here and get it out himself, if he thinks he can do better than me," was his reply to the messenger boy, and Terry grinned some more. The next news that came was that 621 was stuck in the snow two miles out. Terry gave silent grin No. 3. By this time the super got on the ground, clothed in all his official dignity. He took charge of the job, but made a poorer fist of it than the section boss. At last he came up and condescended to advise with Terry.

"Mr. Harding," said Bennett, "this is all boys' play. Spectators are laughing at us at the way we are bullheading this job. The section boss has his hands tied by the messages he is getting thrown into him by Deegan, and he can do nothing."

"Damn Deegan," said the super, impulsively. "Amen!" said Bennett, "it is a poor preacher than cannot have a clerk."

"Mr. Bennett, what can we do?"

"Get the plow turned; run up to the stalled train, dig it out, pull it back here into the yard, then run the plow ahead of it, and the game is won."

"And why don't you do it?"

"Because I lack the authority. You, as superintendent, have charge of us all. Stand over there so you can be heard, and give me orders. I'll do the rest."

In reply to the super's instructions, Terry ordered all hands to widen out the banks. This took one hour. Then the plow was turned, and the 50 men, who were hired for shoveling, ordered to get aboard to relieve the stalled train. In an hour more it was back in the yard. The plow was sent out and 621 was sent after it.

The general superintendent ordered a rigid investigation through the division superintendent of the cause of the delay to train 621. He would not be satisfied with

the condition of the weather for an answer.

Roundhouse Foreman Bennett, Roadmaster Deegan, Section Boss Donohue and Jim Kelly were all summoned before Harding after the storm for investigation. The interview was a give and take of flabbergasted slobber between the contesting parties, until Bennett rose "to a point of order."

"State it, Mr. Bennett," said Harding. "You might as well be trying to educate a pig to use a napkin when it is being served with breakfast after a long fast as to talk sense to Mr. Deegan. I have endured patiently for years the smashing of cylinder cocks, tearing off of brake rods and ashpan slides, derailling of engines and the Lord only knows what not, by the piles of accumulated ashes in that locality. You would yet be in ignorance of my sufferings but for the detention of the limited that morning. It costs more in one year to the company to take away the ashes than a modern method could be put in for. I understand a yellow pine tie, such as we use, costs one dollar when it is tamped under the rails. We burn out 60 of them every year. Add that to the damage to engines, the derailments and the detentions, not to mention the yellow blasphemy sowed so densely around the place, that is sure to produce a crop of vengeance, and you have a nice figure. The great trouble is that Mr. Deegan can see nothing but the cost to his department, and in his own language, 'to the devil with the engines.' I am sick and tired of the deal, and don't give a tinker's damn whether school keeps or not."

Bennett sat down, swabbing his face with his handkerchief; Deegan took the floor to reply, but Harding told him to sit down again, that he, too, was sick of threshing out old straw. He then asked Bennett if he could suggest a remedy.

"Yes, sir! Give me 200 dollars to spend and I'll hold myself responsible to you for all the trouble occurring on the wheel track hereafter."

"Go ahead," was the laconic reply, as he dismissed the seance. Terry lost no time in putting his plan into operation. He hired six men to excavate a pit parallel to the wheel track; got the section boss to put in a frog and lay the rails sufficiently long for two cars, which he had made out of two old gondolas, so as to have them dump without much shoveling. He then got 20 bags of cement, and made forms of boards 16 ins. at the base, tapering to 10 ins. three feet up, fashioned for holding three locked rails to lay in, and drilled the rails to apply studs to hold the track rails in place, assisted by binders from side to side. He stood the "posts" of cement 6 ft. apart. He then put a layer of cement over the floor of his improvised pit, which made first class shoveling for Kelly. He notified Mr. Harding when the job was completed and request-

ed him to have the yardmaster run out the two cars every time when loaded. After that there were no more breakages or derailments on account of ashes being piled up over the rails. The job cost \$116.11, and it paid for itself in less than six months in Kelly's wages alone, as it took him but 5 hours daily to shovel the pit, wherein he sweltered in sweat, blowed and boozed every 10 hours before the change was made. The turntable, engine house and approaches were kept clean, besides the pit, all for \$1.25 a day; and Kelly had time to chat with a chum, telling how he made Deegan hunt his hole in the bargain.

Pictures of the Mono-Rail Railway.

A very interesting moving picture was recently shown at one of Mr. F. F. Proctor's New York theaters. It was operated on one of the well known Paley's Kalatechnoscopes, a projecting apparatus which moves, halts and illuminates the numerous tiny photographs on the long celluloid film.

The pictures shown were of the celebrated mono-rail railway in Ireland, and the operation of switching and running the train were shown just as they had taken place.

The track stands upon a steel structure in the shape of the letter A, and twin locomotives, that is with two boilers, one on each side of the structure, run along pulling cars which hang down on each side of the mono-rail in the same way.

The wheels which carry the weight of the train run on the top of the structure, which corresponds to the sharp top of the letter A, but there are also wheels which run along near the bottom of the structure and so prevent any swaying or rocking.

The operation of switching the engine onto its train is interesting; where shop and main line tracks intersect there is a section of mono-rail which turns upon a pivot like a turntable. This is first set to join the shop tracks and the engine comes ahead onto the movable structure and is turned, and backs onto its cars and is ready for the trip. It is a most interesting series of pictures, and Proctor's New York audiences had the pleasure of seeing how this mono-rail railway is run in the Emerald Isle.

A Railroad Accident.

Johnny had a train and engine

That would steam across the floor,
With a clatter, shriek, and whistle
And a roar.

Many cargoes did they carry
Round the perils of the bend;
Now a misplaced switch has sent them
To their end.

But one day they made a journey

While his father stormed in vain,
And the switch was used on Johnny—
Not the train.

Railway and Locomotive Engineering

A Practical Journal of Railway Motive Power and Rolling Stock.

Published Monthly by
ANGUS SINCLAIR CO.,
174 Broadway, New York.

Telephone, 984 Cortlandt.
Cable Address, "Loceng," N. Y.
Glasgow, "Locanto."

Business Department:

ANGUS SINCLAIR, President.
FRED M. NELLIS, Vice-President.
JAMES R. PATERSON, Sec'y and Treas.

Editorial Department:

ANGUS SINCLAIR, Editor.
F. M. NELLIS,
GEO. S. HODGINS, } Associate Editors.
JOS. A. BAKER,

Advertising Department:

Eastern Representative, S. I. CARPENTER, 170 Summer St., Boston, Mass.

Western Representatives:

JOS. A. BAKER and F. B. LAWSON, 1204 Monadnock Block, Chicago, Ill.

British Representative:

THE LOCOMOTIVE PUBLISHING CO., Ltd., Amen Corner, Paternoster Row, E. C., London.

Glasgow Representative:

A. F. SINCLAIR, 15 Manor Road, Belahouston, Glasgow.

South African Representative:

E. MILLS, P.O. Box 1416, Cape Town, S.A.

SUBSCRIPTION PRICE.

\$2.00 per year, \$1.00 for six months, postage paid to the United States, Canada and Mexico. For other parts of the world, \$2.50 or ten shillings. Single copies, 20 cents. Remit by Express Money Order, Draft, Post Office Order or Registered Letter. Mailing address can be changed as often as necessary—always give old and new address, and if you subscribed in a club, state who got it up. Please give prompt notice when your paper fails to reach you properly.

Entered at Post Office, New York, as Second-class mail matter.

Copyright by Angus Sinclair Co., 1904.

For Sale by Newsdealers Everywhere.

Professor Goss on Compound Locomotives.

After discussing the increase of locomotive boiler pressure which rose from 130 pounds per square inch in 1880 to above 200 pounds in 1900, Professor Goss insists that the only way to utilize this high steam pressure is by the use of compound locomotives. The disappointment and troubles experienced with American compound locomotives were briefly discussed and the author said that in some cases the compound locomotive has proven expensive to maintain, in others ill-adapted to the service expected of it. Compounds should not often be used under conditions requiring frequent starting and stopping, or when changes in the grades require frequent changes in the conditions of operating. It is on the long, steady pull that they show their largest gains over that of the efficiency of the simple engine.

The author of the address also points out that more saving of fuel was expected than what the conditions of operating warranted. It was expected that a percentage of the whole of the fuel consumed by a compound locomotive would show a proportion of economy.

whereas only about 80 per cent. of the fuel used is burned when the engine is working steam through the cylinders.

In spite of the disappointments met by the users of compound locomotives, Professor Goss expressed confidence in the future success of that form of engine. He said that in compounding we are committed to the four cylinder type, and he held that the de Glehn balanced compound, which for several years has been the standard for all new passenger power on several of the leading French railways, is the ideal compound locomotive.

Most of our readers are familiar with the appearance and details of construction of the de Glehn compound through the illustrations and descriptions of the engine that have appeared in RAILWAY AND LOCOMOTIVE ENGINEERING, and those who have attended the St. Louis exhibition have enjoyed the privilege of examining an excellent specimen of the engine in the exhibit of the Pennsylvania Railroad. Nevertheless, we think that most of our readers will be interested in Professor Goss' description and discussion of the de Glehn compound as follows:

"In the de Glehn design, the two low-pressure cylinders of a four cylinder compound are placed side by side between the frames, and connect with inside cranks, which are set quartering on the forward driving axle. The details of these cylinders and surrounding parts are similar in every respect to those of all inside connected engines. Thus placed the low pressure cylinders are well protected from radiation, and they connect with exhaust passages, which are both short and direct. The high pressure cylinders are placed outside the frame and connect with outside cranks in the wheels of the second driving axle. These cylinders are not in the same cross section with the low pressure cylinders, but are carried back on the frames a distance which is substantially equal to the spacing of the driving axles, so that the main rod of the outside cylinder connecting with the second driving axle is no longer than the main rod of the inside cylinder connecting with the first driving axle. The side frames between the high pressure cylinders are strengthened in substantial cross bracing in the form of a casting, which, so far as the frames are concerned, serves the purpose of a false saddle at this point.

"The two or more pairs of driving wheels are connected by coupling rods, the several cranks being so arranged that the pins for the coupling rods in the front drivers are set diametrically opposite the inside cranks of the axles carried by these wheels. When one of the outside pistons moves forward, an inside piston moves backward, the reciprocating parts of each high pressure

cylinder being balanced by the reciprocating parts of its neighboring low pressure cylinder. If, under these conditions, each wheel is perfectly balanced for its revolving parts, and if the reciprocating parts of the high pressure engine have the same weight with those of the low pressure engine, the machine, as a whole, will be balanced, both horizontally and vertically. So far as the action upon the track is concerned the balance will be practically perfect.

"It will be seen that the machinery of these engines, as compared with that of an American two cylinder engine, involves nearly double the number of parts. Thus, the French engine may have the same number of axles and wheels, but all other machine parts, such as pistons, cross heads, main rods, valve motions and valves are in duplicate. Each cylinder is treated as a complete unit, having its individual cross head and its individual main rod. There are four sets of cross heads instead of two, as in American practice, and four main rods instead of two. But these apparent disadvantages are more than compensated for by the increased lightness of the parts involved, and by the possibility of a higher character of design. In American practice, the two main rods of a modern engine must each be designed to transmit from 800 to 1,000 h.p. That this may be accomplished, rods have become enormously heavy and crank pins have grown to be as large as axles were 10 years ago. Moreover, the forces to be transmitted often exceed the ability of the fixed portions of the machine to withstand properly, hence parts strain, journals and brasses fit badly, and hot pins and boxes result. An American locomotive, if designed after the de Glehn type, would have four rods, each transmitting from 400 to 500 h.p., and the rods themselves would be light. The pins, while comparatively small, would afford liberal bearing surface without exceeding a convenient limit in size, and concentrated stresses upon all fixed parts would be reduced. In such a case, who shall say that the duplication of parts when offset by such obvious advantages, increases the chances of failure? Is it not conceivable that under the conditions which have been described a large number of parts may even involve fewer chances of failure?

"Another objection often regarded as insurmountable by the American designer, is that the inside cylinders necessarily connect inside of the frames, and, hence, a crank axle is necessary. When this objection is analyzed, it is found to be based in part upon the extra cost of a crank axle, and in part upon experiences of long ago. Early American engines which were fitted with crank axles were very flexible and were frequently run over exceedingly rough track. The

record shows that in such engines there were numerous failures of axles. We, therefore, said, and for years have continued to say, that we will not use the crank axle. Our modern engine, however, is less flexible than the earlier one, and is less subject to strains through inequalities in the track. Our advantages in this respect are at least equal to those of other countries. If England and France can run crank axles, why may we not do the same? The fact that these countries do use them, and meet with few failures, would indicate that the American objection is largely historic.

"But the French compound presents another side to the axle question too important to be overlooked. The problem of transmitting 1,500 or 2,000 h.p. through a single locomotive axle has in American practice led to the adoption of axles of very large diameter. In spite of this fact, axle failures on heavy engines are by no means unknown. With steam pressures and cylinder diameters still tending upwards, where is there sign of relief? Here, again, we can well afford to look with favor upon the French compound, for by its design the total power of the engine, instead of being transmitted through a single axle, as in American practice, is divided between two. The inside cylinders connect with the forward axle, and the outside cylinders with the rear axle. By the adoption of the de Glehn type, no single axle of our modern engines would be called upon to transmit as much as a thousand horse power, and present diameters could be materially reduced, and at the same time allow a wider margin of safety. The balanced compound, therefore, instead of introducing axle troubles, may reasonably be expected to lead to a betterment in present conditions. The advantages of the French type may be summarized as follows: It solves completely the difficult problem of balancing drive wheels, it constitutes a satisfactory system of compound cylinders, it avoids the concentration stresses in frames, it divides the total work of the cylinders between two axles instead of concentrating it in one, and the dimensions of the details of its machinery are such as will permit them to be well designed."

Victory for Railway Brotherhoods.

The Brotherhood of Locomotive Engineers and Brotherhood of Locomotive Firemen have just passed through one of the most momentous events in their history; and the organizations are indebted to the ability and tenacity of their grand chiefs for a peaceful victory which will in times to come exercise highly beneficial influence on the fortunes of railroad brotherhood men generally. Largely through the influence of these brotherhoods, the Interborough Company, of

New York, have consented to select a large percentage of the Elevated Railroad motormen to be motormen at \$3.50 per day on the underground railroad about to be opened for business. This is the same rate of pay now received by the Elevated Railroad motormen. When the change from steam to electricity was made by the Manhattan Company a few years ago, the position of motormen was given to the engineers at the same pay they had been enjoying on the steam engines, treatment which was considered very favorable and that was permitted to establish the rate of pay for all new motormen. Firemen held for promotion to motormen were given the same pay as the engineer-motormen.

When the new subway or underground system, which has been under construction for several years, was nearly completed, the Interborough Company, which is the successor of the Manhattan Company and controls both the Elevated and the Underground railroads, intimated that new men would be employed on the Underground Railway as motormen at \$3.00 per day. The motormen on the Elevated system claimed promotion to the underground and demanded the same pay as the Elevated men are now enjoying. The officials of the Interborough Company refused at first to consider such a claim, but appeal was made to the brotherhoods for assistance which was readily granted, and ended in the Interborough Company signing an agreement which is not only very advantageous to the men who belong to the brotherhoods, but is unusually equitable towards the whole of employees of the underground system.

The day's work for motormen is to be ten hours or less on the subway line; men are to be promoted to motormen at \$3.00 a day for the first six months; at \$3.25 for the ensuing six months, and at \$3.50 after one year. Conductors are to receive \$2.10 for a day of ten hours for the first year; \$2.25 for the second year; \$2.40 after the second year.

Guards, men employed till January 1, 1905, \$1.70; guards employed after January 1, 1905, \$1.55 for the first year; \$1.70 for the second year; \$1.80 after the second year, and \$1.95 after the third year. Hand switchmen, \$2.00 for the first year; \$2.35 after the first year. Towermen, \$2.40 for a day of eight to ten hours, first year; \$2.50 after the first year. Agents, \$1.75 for a day of twelve hours, first year; \$2.00 after the first year. Platform men, \$1.75 for a day of twelve hours. Gatemen, \$1.40 for a day of twelve hours, first year; \$1.55 after the first year.

No motorman is to be discharged for serving on any committee, or discharged or suspended for any cause without a fair and impartial hearing. If suspended he shall receive full time and pay for such suspension if exonerated. A committee representing the motormen is to have

recognition in adjusting a grievance between the company and its motormen. If a motorman is aggrieved he may have his grievance presented through the committee representing the organization of which he is a member.

Employees of the subway division of the Interborough are to consist of the employees of the Manhattan Elevated Railway division in the following proportion: Motormen, 50 per cent.; guards, 50 per cent.; switchmen, 50 per cent., providing that number apply and qualify, and such other employees from the Manhattan division as it is possible for the company to place in the subway.

From the Brotherhood standpoint, the most important part of the agreement made with the Interborough Company is that it will form a basis for agreement with other steam railroad companies when they change part of their power from steam to electricity. Changes of this kind are merely in their infancy and it needs no son of a prophet to foresee that within a few years most of the urban and suburban passenger traffic now operated by steam locomotives will be changed to electricity.

To meet the new conditions the brotherhoods of locomotive engineers and firemen will require to make room for certain classes of electric motormen joining their ranks, otherwise they will receive the burden of defending and protecting the interests of a class of men that will bring in no new strength or power.

Piston Packing.

Students of the development of the steam engine are constantly receiving surprises about how the pioneer improvers of the engine were able to obtain a fair service of efficiency with the crude appliances they were compelled to employ. Think of getting work out of steam with a piston that had no packing! In the present day there are pistons working very successfully without packing, but they fit the perfectly true cylinders so exactly, that there is little or no leakage. It was very different in the early days when cylinders were merely approximately round and frequently were not bored out.

The first forms of steam engines used employed steam very little above atmospheric pressure, merely enough to produce a vacuum when it was condensed; but after people began to use steam that was 10 or 15 pounds above atmospheric pressure, it was absolutely imperative to devise some means of preventing the steam from passing freely between the piston head and the walls of the cylinder.

What naturally suggested itself to the pioneer engineers at first was to put fibrous packing around the piston head, a practice which was followed for many years. Making a piston packing ring

came to be a very elaborate operation. To do the job properly called for patience, industry and no little skill. Here is a description of how to do the work taken from Bourns' Treatise on the steam engine:

"To pack the piston, take sixty common sized white or untarred rope yarns, and with them plait a gasket or flat rope, as close and firm as possible, tapering for 18 inches at each end and long enough to go around the piston, and overlap for that length. Coil this rope the thin way as hard as you can, lay it on an iron plate and beat it with a sledge hammer until its breadth answers its place; put it in and beat it down with a wooden driver and a hand mallet. Pour some melted tallow all round; then pack in a layer of white oakum half an inch thick, then another rope, then some more oakum so that the whole packing may have the depth of about four inches, or only three inches if the engine is a small one. Cast segments of a circle of lead about 12 inches long, 3 inches deep and $1\frac{1}{4}$ inches thick, fitted to the circle of the piston and cut down square at both ends. Lay them round upon the packing as close as they can lie to one another without jamming, and screw down the piston springs upon them. The piston springs should be bent downward at the end next to the piston rod, and a little mortise should be cut in the cast iron there, for the bent-down point of each of them to lodge in, which will prevent their coming forward to touch the cylinder. Previous to the piston being put into the cylinder, the hollows among the crosses should be quite filled up with solid pieces of pine wood, put in radius fashion. The packing of the piston should be beat solid, but not too hard, otherwise it will create so great a friction as to hinder the easy going of the engine. Abundance of tallow should be allowed it, especially at first, the quantity required will be less as the cylinder grows smooth."

The first metallic packing was proposed by Cartwright in an engine patented in 1798 as a rival to Watt's engines. The engine was a complex affair which never was built, but his specifications for a piston, made of metal packed with two sets of metal rings forced out against the sides of the cylinder by steel rings, appealed to the engineering acumen of many engineers and metallic packing began gradually to come into use.

Metallic rings kept expanded to fit the cylinders was the popular form for many years, until forms of patented packing in which the rings were kept expanded by the steam became popular. Their popularity was due to the fact, that their use saved the work of examining the piston packing at short intervals to set the springs out to expand the packing. Then came the packing made of cast iron rings

with sufficient natural spring to hold themselves up to the cylinder walls without the aid of springs. That form is now almost universally used, but it is not because it is the most economical packing, but because it needs little or no attention. There is no doubt that the common steam packing frequently puts great unnecessary pressure upon the cylinders, and wastes a large percentage of power in moving the piston.

Certain patented pistons which enjoyed great popularity for years were formed of a multitude of parts which was contrary to all sound principles of machine design; but they were used for years through the force that proprietary interest exercised. Most pistons have now reached the limit of simplicity, but that has been attained frequently by the sacrifice of economy.

A well known master mechanic who had been a locomotive engineer, speaking at a Master Mechanics' convention, asserted that an engine he was running when equipped with the old form of spring expanded packing could haul two extra cars and make the time of a passenger train easier than it could with a patent packing which had the same effect as the present spring packing. Every observing man who has run locomotives with the various kinds of packing has had similar experience.

There is no part about a steam engine of equal importance to the piston which has received so little care and intelligent attention. Piston rings out of round are habitually applied and permitted to wear themselves to fit the outline of the cylinder. If the loss that results from leakage of steam and overcoming unnecessary friction were accurately known the rings would be fitted as carefully as those of a triple valve piston.

Proposed 100 Miles an Hour Railway.

We are constantly hearing demands for exceedingly fast trains on railways where the express passenger trains return little profit to the companies operating them, and travelers display no disposition to help in paying the expense of accelerating the trains. On that account the hundred mile an hour train has never got beyond the experimental point. But there is now some prospect of a high speed electrically operated railway being put in service between two large cities in Germany—Berlin and Hamburg. The scheme is promoted by Siemens & Halske, the great electrical company, and is likely to be pushed through if the required permission is obtained from the German Government, and stock in the enterprise liberally subscribed for.

The project does not appear to be a very promising one financially, for the business between the cities is now performed by ten passenger trains daily, carrying an average of about 1,100 passengers. The high-

est rate of speed is about 51 miles an hour; and the average fare paid is under two cents a mile. It is proposed to encourage increase of traffic by providing a train every half hour run at a speed of 160 kilometers, nearly 100 miles an hour. Extraordinary facilities sometimes effect decided increase of passenger business, but we do not believe that the increase of travel between two cities that have an aggregate of about two and a half million inhabitants little given to the luxury of train riding, would make a fast train service pay. We would have more confidence in the financial success of such a railway between New York and Philadelphia.

American Railway Appliance Exhibition at International Railway Congress.

The International Railway Congress is a most dignified and influential organization with headquarters in Brussels, Belgium. It meets in convention once in five years to discuss important matters connected with railway interests, all past meetings having been held in leading European cities. The next meeting of this Congress will be in 1905, and arrangements have been made to hold it in Washington. The event is of international importance, especially for railway interests of every kind, as the members are the most influential railway officials in the world, and a large attendance is certain. As a courtesy towards the persons of high degree who will attend this Congress, the Association of Railway Supply Men are arranging to hold an exhibition of railway appliances similar to the exhibits displayed at the annual railroad mechanical conventions, but on a larger and more elaborate scale. A general committee of arrangements has been formed which comprises the most influential names connected with the railroad supply business, with Mr. George A. Post, president; Mr. Charles A. Moore, treasurer, and Mr. J. Alexander Brown, secretary and director of exhibits.

The arrangements for holding the Congress are under the immediate charge of the American Railway Association, and the president, Mr. Stuyvesant Fish, will preside over the American section of the Congress. Mr. Fish and the American Railway Association are cordially supporting the proposed exhibition of railway appliances, so that the exhibitors will enjoy the unusual benefit of having their appliances examined by the men who rule the railway hosts of all countries where railroad transportation is in use.

In an address made by President Post on the purposes of the exhibition, and issued as a circular, he says: "To make it a success requires that the

manufacturers of railway appliances of our country shall be acquainted with the great privilege to be accorded them through the medium of the proposed exhibition. If the exhibition of our wares before the numerous associations of the various branches of the railway industry in our country, which meet annually, have proven of value to us, and we know they have, then it requires no argument to prove that an exhibition that will be witnessed by railway managers from all over the world, cannot fail to be productive of results that will ramify through all the arteries of the railway supply trade, giving wider markets for our goods, and adding to our wealth and prestige.

"To the manufacturer who seeks export trade, the presence in this country of over five hundred foreign railway men with the power of purchase, with the time and inclination to examine his product, is surely a consummation devoutly to be wished. To him such an opportunity was never before offered. This will be distinctively an exhibition of railway appliances for the exclusive scrutiny of railway men. It will be held in a city wherein there is less to detract from the importance of this particular exhibition than would be the case in any of the great commercial centers of the country. It will be held at a season when the Federal Congress is not in session and there will be better facilities for accommodating the crowds that will attend the International Congress and our exhibition than otherwise."

It is proposed to hold the exhibition in the "White Lot," which is a government reservation, and an act of Congress is necessary to grant the privilege of holding the exhibition there. We urge our readers who have friends in Congress to use their influence to have the act passed granting the use of the "White Lot," with the least possible delay.

The Value of Daily Newspaper "News" Concerning Railroads.

A Buffalo daily paper asserts with all the solemnity which usually attaches to real news, that Mr. J. F. Deems, the general superintendent of motive power and rolling stock of the New York Central Railroad, has invented a rotary locomotive, in which "steam is sent from the boiler to the axles and the wheels get four impulses to each revolution. This gives unlimited possibilities for speed, and it may be a setback to the advance which electricity has made as a motive power." As a finishing touch to this fascinating prospect, Mr. Deems, when shown the item by RAILWAY AND LOCOMOTIVE ENGINEERING, said that there was not one word of truth in the statement,

and that he was at a loss to know how such stuff got into the papers.

Another item printed in a prominent New York daily stated that the New York, New Haven & Hartford had recently appointed two traveling inspectors to study the smoke problem, and another paper, printed in the great center of American culture and learning, gave a circumstantial account of how this company were using two headlights on their new air line flyer engines set at an angle to each other, so that they were practically cross-eyed headlights, and placed so that each threw a light across the other's rays, and this arrangement was said to be useful in rounding curves. Investigation proved that the officials of the road knew nothing about either announcement.

Mark Twain once said that when a man knew nothing of a subject he ought to be able to talk fluently about it because he was not "hampered with facts." A humorous writer some years ago said in our columns, while the coal saving idea was new on railways, that he was prepared to demonstrate even on rough brown paper and with any kind of a pencil that his device would save 40 per cent. The examples we have given show the degree of "accuracy" of many items of so-called railroad news found in otherwise reliable papers. A vivid imagination, lots of ink and paper and a good pen appear to be the principal requisites for many of the railroad paragraphs which one comes across.

Out of Sympathy With the Men.

We all know the fable of the fairy godmother who conferred all good gifts upon a child but withheld one which proved the undoing of all the other precious gifts. I have often thought of that story in connection with the failures of my friend, Samuel Short. Sam learned the machinist trade and no man surpassed him in skill in any shop he ever worked. He was an industrious student of the principles underlying the machinist business, he was very careful and methodical in his work and seemed to have the qualities of an ideal foreman. In due course Sam was appointed foreman, and from the first he made a failure. He had no capacity for handling men. From the first he was one-sided, and had no sympathy for the men under his charge. A good-natured man, he became a tyrant with those who did not perform up to his own ideal. While zealous for the good of the company, he never realized that he had responsibilities toward the workmen that were greater than merely seeing that the full pound of flesh was paid. No man can keep men doing their best who is not in constant sympathy with them.

Borrowing Trouble.

There is said to be some uneasiness among trainmen of the Pennsylvania Railroad that the management are considering the advisability of adopting a Baltimore & Ohio practice with freight train conductors. On the Baltimore & Ohio road one conductor is given charge of three trains—time freights. He gives the manifests of the first two trains to the engineers to deliver after their destination is reached, and follows on the third train. This plan is only followed on fast freight trains with a small number of cars. We think that the Pennsylvania trainmen are borrowing trouble on this question. That company has always been noted for following safe methods. Putting unnecessary work on engineers and conductors is not conducive to safety.

Book Review.

Rights of Trains on Single Track. By Harry W. Forman. Publishers, *The Railroad Gazette*, New York, 1904. Price, \$2.50.

This book is an exhaustive commentary on the standard code of train rules of the American Railway Association, and is a thorough study of the subject. Mr. Forman, who is a chief dispatcher on the Denver & Rio Grande, has been an examiner of trainmen and operators on that and other roads for many years. An independent writer, such as Mr. Forman, is free from the restraints of a committee, and he avoids the pitfalls that surround a speaker in a convention, so that Mr. Forman's book is really the first comprehensive and satisfactory study of the Standard code that has ever been written.

The book is written in the form of questions and answers, like the "Catechism of the Locomotive." These questions number nearly twelve hundred, covering all the intricate questions that come up in examinations. Where the answer is long and susceptible of treatment in the shape of a little lecture, such a lecture is given. Every Standard rule is considered and the most common supplementary rules such as additions to 83, 104, etc., are fully discussed. In this writer we have a train rule expert who, while possessing the patience and close application necessary to plod through the interminable details of train order forms, at the same time does not lose sight of broad, general principles.

The book is pocket size, 4 1/4 x 7 ins., bound in leather and has round corners. It has 477 pages and altogether presents a very attractive appearance.

The U. S. Government has given a contract to a Selma, Ala., company to build several thousand dump cars to be used in the construction of the Panama Canal.

Questions Answered

CAPACITY OF STANDARD BOX CAR.

(66) A. S. B., Scranton, Pa., writes: There is such a variety in the size and capacity of box cars that the expression "car load" is about as intelligible as the expression, "about the size of a piece of chalk." A party of railroad men were discussing this subject and one member of the information bureau maintained that there is a standard size of box car but could give no particulars, so we decided to refer the question to *LOCOMOTIVE ENGINEERING*. A.—The standard box car, as established by the M. C. B. Association, is 36 ft. long, 8 ft. 6 ins. wide and 8 ft. deep inside. It has an inside capacity of 2,448 cubic feet. It carries without difficulty 1,800 bushels of wheat weighing 60 pounds, making a total load of 108,000 bushels. With land producing 30 bushels to the acre, a single car will carry away the crop from 60 acres of land. A train of 50 such cars will carry away the product of 3,000 acres.

TIRE SHRINKAGE.

(67) E. G., Phillips, Me., writes: How much draft should I give a locomotive driving tire on a cast iron wheel center? A.—For a wheel 28 ins. diameter the old rule which allows $\frac{1}{16}$ of an inch for every foot of diameter is a good rule to follow. This is equivalent to allowing $\frac{1}{1200}$ of the diameter in inches. This rule of allowance is departed from in some cases; for example, some shops allow the $\frac{1}{1000}$ of the diameter in inches for tires, say, from 56 to 78 ins., and for steel centers, particularly if the rims are light, from 78 ins. upward the allowance is $\frac{1}{500}$ of the diameter.

HEATING SURFACE TO HORSE POWER.

(68) B. Y., Detroit, Mich., writes: In calculating the power that a locomotive ought to develop, it seems to me that the heating surface ought to be the basis of calculation. Can you tell me how much heating surface ought to be provided for every horse power to produce an economical locomotive? A.—From $1\frac{1}{2}$ to $2\frac{1}{2}$ sq. ft. of heating surface to each horse power is the common practice. The more heating surface the better, under common sense limits.

INSPECTION OF STAY BOLTS.

(69) R. M. B., St. Louis, Mo., writes: I am in charge of an engine house doing business all the time beyond the convenience provided, and a great many things have to be neglected. Among them is the systematic inspection of stay bolts. I try to have the stay bolts tested every time an engine is washed out, but often cannot spare the time. I should like to know the rule in the principal

roundhouses about inspection of stay bolts. A.—Some companies require stay bolts to be inspected weekly, others monthly. Monthly inspections are most common, but they ought to be made oftener.

PIPE CAPACITY HEATING SURFACE AND AIR VOLUME.

(70) F. C. B., Tiburon, Cal., asks:

(1) If I were instructed to replace a 2 in. water pipe with one of double the capacity would a 4 in. pipe be the correct size? A.—No. A $2\frac{7}{8}$ in. pipe would be nearly correct. Doubling the diameter increases the capacity four times. The area of a 2 in. pipe is 3.1416 ins., of a $2\frac{7}{8}$ in. 6.4918, and a 4 in. 12.566 ins.

(2) How can I find the heating surface in a tubular boiler? A.—Multiply $\frac{3}{4}$ the circumference of boiler by length of boiler in inches, and add to it the area of all the tubes.

(3) How am I to calculate the amount of air that can be produced by a compressor? A.—Find the area of the cylinder and multiply that by the strokes; then multiply result by 2 if a straight line compressor; by 4 if a duplex compressor; or by 2 if a compound duplex compressor. Divide the result by 1728, which will give the amount of air per stroke, and then multiply by the number of strokes per minute.

(4) We have a compressor whose steam cylinder measures $12\frac{1}{2}$ ins. and air cylinders 15 ins. diameter. With 100 lbs. boiler pressure we get 125 lbs. gauge pressure on the air gauge, how is this done? A.—In addition to the steam pressure exerted on the piston the weighted fly wheels produce the additional power to make the increase possible. They also prevent the engine from stopping on the two dead centers.

ENGINE SAID NOT TO TRACK NORMALLY.

(71) A. G. T., Hobart Mills, Nev., writes:

(1) Will you please explain what is the matter with this engine? She is an 8-wheel engine, when running ahead on a curve the drivers will hug the inside rail. It does not matter which curve, either left or right. When backing up she seems to be all right and rides easy. Just as soon as started ahead the back end of engine will swing to the inside rail, if on a curve, and she rides very hard. A.—If this case has any foundation in fact all the special features of wear should be carefully noted before any intelligent answer can be given, and the construction of the engine would have to be most fully described. More information is necessary.

Signals and Signaling.

BY GEORGE SHERWOOD HODGINS.

(Continued from page 353.)

ELECTRIC LOCKING AT INTERLOCKED CROSSINGS OR JUNCTIONS.

The fundamental principle which is the basis of all interlocked signaling is very concisely put by signal engineers when they say, "The switch-locks lock the switches; and the signals lock the locks." This rather clever shorthand formula means, when translated into ordinary commonplace long hand, that the signalman in an interlocking signal tower, who desires to "set" a route must have all his signals in the "stop" position, and that his first move must be to unlock the switch or switches which he desires to move, and having then moved it or them, he must lock the switch or switches in a new position before he can indicate the route by the signals, and once having indicated the route he thereby locks up the switch-lock levers in the tower, so that while the signals show a certain route clear, no possible alteration of that route can be made.

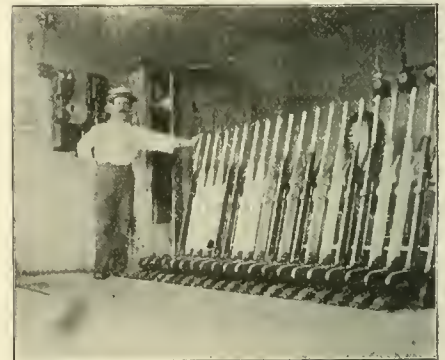

INTERIOR OF ELECTRICALLY INTERLOCKED TOWER—D. L. & W.

In the orderly sequence of events it, however, is quite possible to alter the route "set" within a very short interval of time, and perhaps to the serious disadvantage of a train which has accepted the signals and which comes on apace. It is the object of the electric lock to prevent any sudden or arbitrary alteration of a "set" and indicated route, being made in the face of an advancing train. The electric lock is an additional safeguard which is interposed for the purpose of causing the signalman to realize the situation as it exists before he can hastily effect a change.

There are several ways of producing this result, the first is by the use of what is called a "stick relay" and this may be explained as follows. To begin with a stick relay is one in which when its armature falls away from its magnets its own circuit is broken. When the stick relay is energized the tower switch or derail lock is not in operation. Electric locking provides an extra locking

mechanism in the tower which has for its object the prevention of any sudden or arbitrary alteration of a set route until the passage of the train for which the route has been set. If the signalman desires to "set" a route at an interlocked diamond crossing say from north to south he closes both derailing

switches on this line and by the movement of their levers which operate circuit breakers he de-energizes the locking magnets and the electric tower bolts are dropped. The mechanical interlocking is such that the derailing switches on both the crossing lines cannot be closed at the same time. By closing the derailing switches on the north and southbound track, he has also broken the circuit which held the tower electric lock bolts free and at the same time the mechanical lock bolts have

electrically locked plants a push button placed in the basement of the tower consumes the same time and causes the same deliberate action on the part of the signalman as the mechanical time locks to which reference has already been made.

In other instalments of electrically locked crossing or junction signal appliances the time element is reduced to what arithmeticians would call its lowest terms. In these towers, though the same principle holds good, the necessity for a desertion by the signalman of the operating deck of the tower is not considered essential. In such cases an electric lock is attached to the home signal levers of each track. When the home signal in such an instalment is pulled clear, the movement of the signal lever rotates a notched disk at the back of the machine.

If, however, a route has been set and it is desired to change it without the passage of a train, which is otherwise es-

sential with electrically locked crossings, a mechanical hand release is often provided in the shape of a long screw operated by a hand wheel which moves so that the advance of the butt end of the screw shall be 2½ ins. for 25 complete turns of the hand wheel. The movement of this mechanical hand release operates two dogs each of which has a thin wedge-shaped nose, which when moved in the desired direction pushes the armature lever of the electric lock inward, which action withdraws the locking bolt, just as if the track circuit had been short circuited by the passage of a train.

The slow movement of the screw release is intended to force the signalmen to fully realize and comprehend what he is doing and thus cause deliberate and purposive action on his part, with full knowledge of the situation. In some

ing more definitely, when a train passes the "distant" signal and approaches the tower an indication is given by a miniature semaphore signal in a case on the tower wall and an electric "buzzer" gives audible notice of the fact. At the same time the circuit controlling the electric lock is broken by the movement of the armature of the indicator relay. This allows a counter-balance weight on the locking mechanism in the tower to drop by the action of gravity, engaging with a notch in the circular metal disk turned by the home signal lever movement. This action locks up the route as set and it cannot be changed without the mechanical releasing of the electric lock, or after the train signaled to come on has gone out of the block. This mechanical release is effected by the pressing down of a push button which passes through the enclos-



ENGINE APPROACHING INTERLOCKED SWITCH.

switches on this line and by the movement of their levers which operate circuit breakers he de-energizes the locking magnets and the electric tower bolts are dropped. The mechanical interlocking is such that the derailing switches on both the crossing lines cannot be closed at the same time. By closing the derailing switches on the north and southbound track, he has also broken the circuit which held the tower electric lock bolts free and at the same time the mechanical lock bolts have



TYPICAL RAILWAY BLOCK SIGNAL TOWER.



ENGINE PASSING INTERLOCKING TOWER.

moved home and locked the derails and the north and southbound derails are thus locked closed, while the east and westbound derails are locked open.

The returning of the home signals of the north and southbound line to the stop position, though it closes the pre-

sential with electrically locked crossings, a mechanical hand release is often provided in the shape of a long screw operated by a hand wheel which moves so that the advance of the butt end of the screw shall be 2½ ins. for 25 complete turns of the hand wheel. The movement of this mechanical hand release operates two dogs each of which has a thin wedge-shaped nose, which when moved in the desired direction pushes the armature lever of the electric lock inward, which action withdraws the locking bolt, just as if the track circuit had been short circuited by the passage of a train.

The slow movement of the screw release is intended to force the signalmen to fully realize and comprehend what he is doing and thus cause deliberate and purposive action on his part, with full knowledge of the situation. In some

ing more definitely, when a train passes the "distant" signal and approaches the tower an indication is given by a miniature semaphore signal in a case on the tower wall and an electric "buzzer" gives audible notice of the fact. At the same time the circuit controlling the electric lock is broken by the movement of the armature of the indicator relay. This allows a counter-balance weight on the locking mechanism in the tower to drop by the action of gravity, engaging with a notch in the circular metal disk turned by the home signal lever movement. This action locks up the route as set and it cannot be changed without the mechanical releasing of the electric lock, or after the train signaled to come on has gone out of the block. This mechanical release is effected by the pressing down of a push button which passes through the enclos-

ing case of the release mechanism. The pressure of the button, which can be made without loss of time, lifts the counter-weight clear of the notch in the rotating disk, and thus produces an effect electrically equivalent to the passage of a train over the route set.

This variation in equipment, in which electrical locking is maintained as essential and yet which, in some cases, enforces comparatively slow, but always deliberate and purposive action on the part of the signalman in charge, proves conclusively that safety is the keynote in the whole design, and that while signal engineers may differ as to the advisability of placing more or less time consuming restrictions on the action of signalmen, yet all seem to agree that the best results can only be obtained by compelling the operator in the tower to think before he acts, and that whatever he may do or think, the result shall make always for safe and, after that, expeditious train movement. The whole system of automatic and interlocking block signaling is that whether by day or night, whether by the display of the red horizontal semaphore arm, or the concentrated rays of the tawny caution light, the signal system as operated and maintained, like a

General of Immigration. This was the signal for an ovation, because few labor leaders have enjoyed the confidence of their followers to such a degree as Mr. Sargent did when he resigned his position as grand master of the Brotherhood of Locomotive Firemen. Mr. Sargent extolled the record for good deeds, noble acts of heroism and self-sacrifice of the fireman and his organization.

The first speaker of the evening was Mr. Emerson, Superintendent of Education, who represented his honor, Mayor Knight, of Buffalo. Mr. Emerson gave the firemen a hearty welcome to the city. His story of an honest lawyer captured the house.

Following Mr. Emerson, the Hon. Edward Moseley, secretary of the Interstate Commerce Commission, a true friend of organized labor, presented a most complete survey of the transportation problem and the relation of the railroads to the Brotherhood of Firemen and the public. It was his belief that the 56,000 firemen in that organization comprised the finest body of workmen in the United States, and that they were far above the average both mentally and physically, and capable of enduring immense physical strains. He

alluded to the fireman as the engineer's understudy. From figures compiled and on record in his office he stated that only 17 per cent. of those beginning as firemen ever became engineers, on account of the exacting requirements of the service. Actual experience has proved that five out of every six who

enter the service are unable to withstand the terrible physical strain to which they are subjected in firing the huge monsters of to-day. Mr. Moseley once asked a fireman how often he bent his back during a trip over the division, and received this reply: "Only once, and that is when we start out. When this mill is in action I never have a chance to straighten up." In concluding his remarks Mr. Moseley took exception to an editorial in a New York paper which criticized President Roosevelt for joining the Firemen's Brotherhood, and said that he believed the President should be commended for his action.

Mr. P. H. Morrissey, grand master of the Brotherhood of Trainmen, is a man who commands the respect of the 75,000 trainmen whose destiny he controls, and his love of justice and his conservatism have gained him the admiration and respect of the railroad officials and the public. Mr. Morrissey extended to the firemen the good wishes of his organization. His argument was forceful in support of the belief that public sentiment will eventually correct all existing differences between capital and labor.

Another able and eloquent address was made by Supreme Court Justice Daniel J. Kenefick. He referred to the present law which makes it almost an impossibility for railroad men to secure damages for physical injuries, and advised the firemen to seek by legislation a change in the present laws.

The "hit" of the evening was made by the irrepressible Shandy Maguire. Known by every locomotive engineman on the American continent and noted for his inexhaustible supply of wit and quaint sayings, he kept the audience in convulsions of laughter.

The concluding speaker of the evening was Grand Master J. J. Hannahan, who, owing to the lateness of the hour, gave only a brief history of the order and touched on the manner in which it was elevating the standard of its membership and the good that it was accomplishing.

The opinion generally expressed was that this convention, like its predecessors, would legislate wisely and keep the organization out of unwarranted difficulties.

Something Pneumatic.

The August number of *Something Pneumatic* came to our office recently. It is a monthly magazine devoted to the interests of pneumatic appliances and their motive power. It is published by the Chicago Pneumatic Company, of Chicago. In this issue there is a humorous poem on pneumatic tools, written by a workman who is referred to as the "Man behind the hammer." This man has been rendered so happy by the use of these tools that he breaks forth into song and has given us nine stanzas, in which when praising tools pneumatic he becomes at times emphatic—not to say estatic.

There are several views of this company's factory, its exhibit at the Saratoga conventions and its staff of representatives. The paper on "Compressed Air and Pneumatic Tools in Railroad Service," read by Mr. Thomas Aldcorn before the Central Railway Club of Buffalo, N. Y., is reprinted in full and is well worth reading. A number of halftones showing Chicago Pneumatic Machinery at work ornament the pages of the publication. There is on the title page a very useful convention calendar in which the dates of meetings and the officers of the various associations are given. If you would like to have a sample copy of this publication write to the Chicago Pneumatic Tool Company, Fisher Building, Chicago, and if you mention *LOCOMOTIVE ENGINEERING* they will no doubt forward one to you.

One good turn deserves another.—
Nicholas Nickleby.

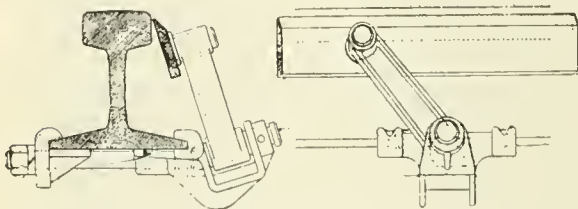

DETECTOR BAR, WHICH PREVENTS SWITCH BEING THROWN WITH ENGINE OR CARS STANDING OVER IT.

witness in court sworn to probity, shall, under examination and cross-examination, speak out with absolute fidelity, the truth, the whole truth, and nothing but the truth.

(To be continued.)

Firemen's Convention at Buffalo.

The ninth biennial convention of the Brotherhood of Locomotive Firemen opened its session at Buffalo on September 12 in as notable manner as befitted that great organization.

In the evening the large convention hall was filled with a representative gathering of delegates, visitors and leading citizens to the number of 3,000, who listened most attentively to the able speeches made by prominent men from all walks of life. The hearty endorsement of the sentiments was evident from the frequent and spontaneous outbursts of applause.

Mr. McNamara, the temporary chairman, after extending a cordial welcome to all, introduced in a few well chosen words the permanent chairman, the Hon. Frank P. Sargent, Commissioner

Air Brake Department.

CONDUCTED BY F. M. NELLIS.

The Automatic Air and Steam Coupler.

There is no doubt that the automatic air and steam coupler has passed out of the experimental stage into the stage of practical utility. We illustrate here the modernized automatic air and steam coupler as manufactured by the Westinghouse Air Brake Co., a large number of which are now in active service.

The introduction of this device on west-

ern roads dates back several years, but its actual service tests in the East began on the Putnam Division of the N. Y. C. & H. R. R. R. four years ago. The device has passed through unusually hard service in suburban traffic on that branch, the engine changing from one end of the train to the other at both terminals. So successful was this test, that upon investigation, the Long Island R. R. Co. decided to equip a few experimental trains on its line with the device about one year ago. This test was very satisfactory, and resulted in the Long Island R. R. Co. placing orders for a sufficient number of equipments to fit its entire number of 565 passenger cars and 170 engines. The usual and annoying congestion of trains at terminal stations on rush days has been entirely eliminated since the adoption of this device.

the Queen & Crescent roads report equally satisfactory results. Aside from the gain in time of train movements at congested terminals, the advantage to the employee is also great. He is not obliged to step between the cars to couple and uncouple the hose or close and open the angle cocks, as the angle cocks are opened with a connecting rod from outside the tracks; neither is he subject

Necessary Changes in Foundation Brake Gear.

A correspondent asks why it is necessary to readjust the length of the rods of the foundation brake gear and move the carrier irons for the levers to a different location on account of the levers striking against the hanger supports or fouling in the strut of the brake beam. This is a pertinent question and a very timely one, inasmuch that cars whose foundation brake gear have been perfectly satisfactory before putting on the slack adjuster have been found to require modifications before the slack adjuster could properly perform its work. In fact, on a number of cars equipped with the slack adjuster, it has become necessary to continue taking up the slack by hand on the dead levers instead of having the adjuster do it in its usual way, on account of the levers striking either on the carriers or in the brake beam strut.

The old method of taking up slack and reducing piston travel was by hand operation of the dead levers on the trucks, thus pulling the slack away from the brake cylinder piston. The slack adjuster, being attached to the brake cylinder, will necessarily take up the slack in the opposite direction. If the foundation brake gear be designed to have the slack taken up by hand in one direction, it must of necessity be taken up in the opposite direction by the slack adjuster and the hangers must therefore be modified. Hence, changes must be made in the length of the rods, etc., on cars equip-

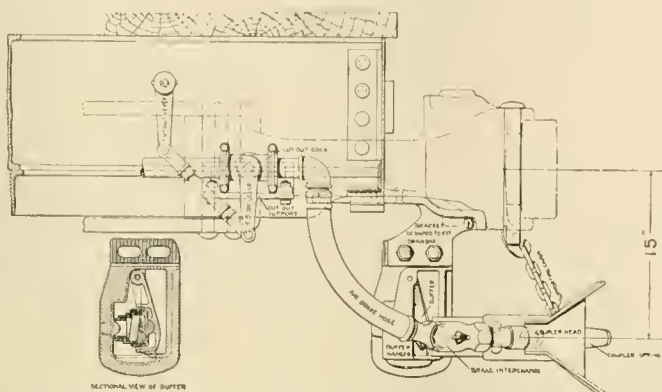

THE WESTINGHOUSE AUTOMATIC AIR AND STEAM COUPLER. SIDE ELEVATION. FREIGHT EQUIPMENT.

ped with the slack adjuster unless the hanger supports are of an unusually liberal length which will prevent the striking of the levers against the supports.

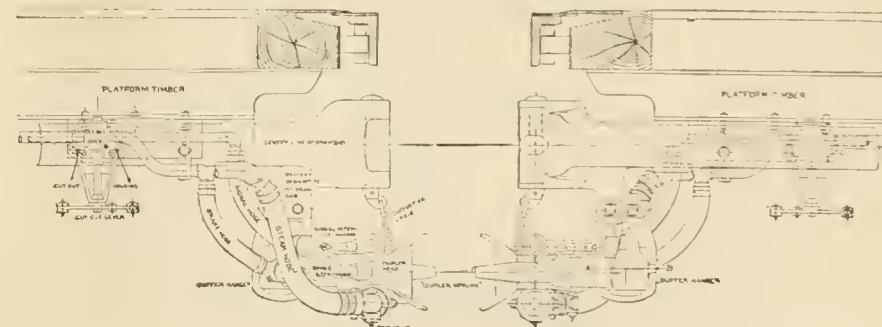

THE WESTINGHOUSE AUTOMATIC AIR AND STEAM COUPLER. SIDE ELEVATION. PASSENGER EQUIPMENT.

The Missouri Pacific has adopted the automatic air and steam coupler for its entire suburban service out of St. Louis, after very complete trials, and it has been found to be a factor of considerable value in the rapid movement of its heavy, short haul passenger schedules. The Texas Midland, the middle division of the Pennsylvania R. R., between Harrisburg and Altoona, the Boston & Maine, and

twenty years' actual service. This test thoroughly evidences the durability of the device. This coupler will operate perfectly on curves of 24 degrees, with 4 ins. variation in height of cars. The couplings are at all times perfectly made, and without friction on the hose gaskets or pull on the hose connections.

Stenciling.

The Buffalo convention of the Air Brake Association brought to light the

fact that considerable unsatisfactory and unreliable stenciling is being done in repair yards on air brake cylinders and other parts repaired. There grew out of the discussion on the subject of stenciling, several methods which are deemed

general air brake inspector of the Central R. R. of N. J., to keep close track of the work done of this nature, which not only gives the date and place of the cleaning, but also the name of the cleaner. With the introduction of the name of the clean-

may safely be followed instead of uncoupling the hose by hand. It is needless to say that this belief is decidedly erroneous and cannot but result in much damage to these parts if the practice is followed up. It is evident to all persons

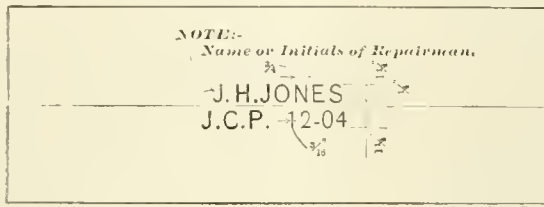

PASSENGER CAR AUXILIARY RESERVOIR.

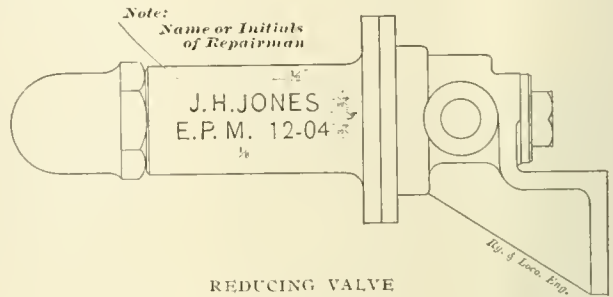

REDUCING VALVE

very good, and which if followed will undoubtedly result in a betterment of brake conditions. The essential feature of these methods is that the name of the person doing the cleaning and stenciling must appear on the repaired part, thus

er, it is believed that there will be less stenciling on the part of the persons who wish to dispose of the car too quickly and dishonestly. These cuts are reproduced through the courtesy of the Air Brake Association, whose Buffalo convention

brought into contact with air brake work that forcibly pulling the hose couplings apart not only upsets and injures the coupling head gasket, but brings an undue strain on the hose, and frequently at that point where the nipple enters the end of the hose. It has been said, and with reasonable justification, that more hose are worn out by being pulled apart than in actual service, properly handled. It is to be hoped that the Air Brake Association and the Master Car Builders' Association will succeed in formulating some arbitrary rule whereby this erroneous belief and practice may be eliminated.

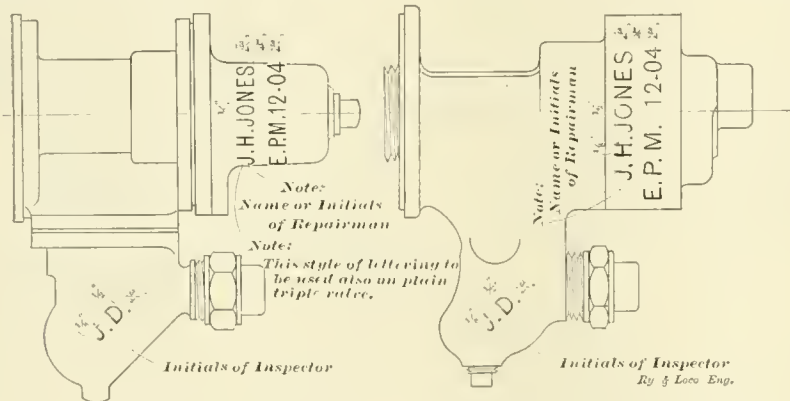

WESTINGHOUSE TRIPLE VALVE.

NEW YORK QUICK ACTION TRIPLE VALVE.

Better Metal Brake Beams Needed.

At nearly every meeting where high speed brakes are discussed, reference is made and considerable attention paid to the point that the levers and the rods may be too light to stand the high pressure of 110 lbs. train line.

While it is true that a good many cars running with the 70 lb. brake at the present time do not have foundation brake gear that is able to withstand the high pressure, still all of these cars and many others are weaker at the brake beams than they are at any point in the rods or

holding him responsible for the work done and the truth of the stenciler. This will undoubtedly produce more wariness on the part of the repair men doing the work with the stenciling brush rather than with the tools and the oil can, which

proceedings treat in detail upon this subject.

Pulling Hose Apart.

There seems to be an impression among some railroad men that inasmuch that

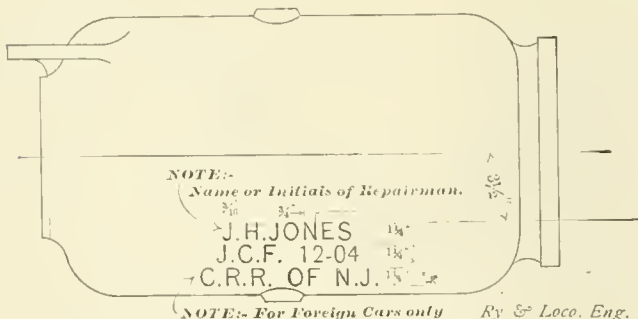

FREIGHT AND COAL CAR AUXILIARY RESERVOIRS.

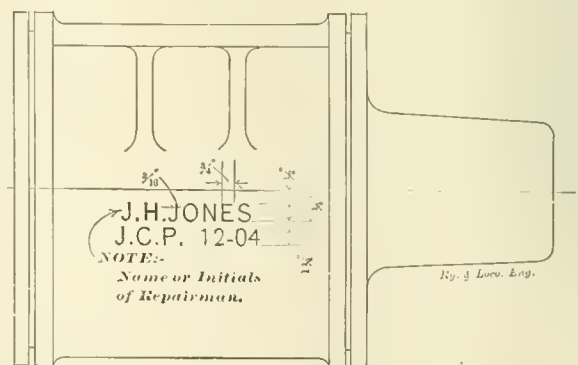

LOCOMOTIVE AND TENDER BRAKE CYLINDER.

has been a bane of triple valve and brake cylinder cleaning for some time past.

We submit herewith illustrations of the method adopted by Mr. T. L. Burton,

two cars whose air hose are coupled together may be pulled apart and the couplings broken without any damage to the hose, that this is the practice which

levers. It seems strange that sight should be lost of weak metal brake beams in these discussions, and entire attention of weakness be paid to the rods and levers.

If a person will take notice they will observe on many freight cars brake beams which are bent up or down in the middle, or strained in such a way that they are bent, and they will see that the weak point really lies in the brake itself in-

wheels only of six wheel trucks, the middle pair of wheels not being braked. From data secured in this stop, two calculated stops were plotted as shown. The first and actual stop was made in 2,300 ft. from a speed of 60 miles per hour,

ft., or just half the distance of the low pressure, improperly braked train in the stop first made. This is interesting data to air brake men, and is an extract from a paper on high speed brakes submitted by Mr. L. M. Carlton, general air brake inspector, Chicago & Northwestern Ry., at the Traveling Engineers Convention in Chicago, September 15, 1904.

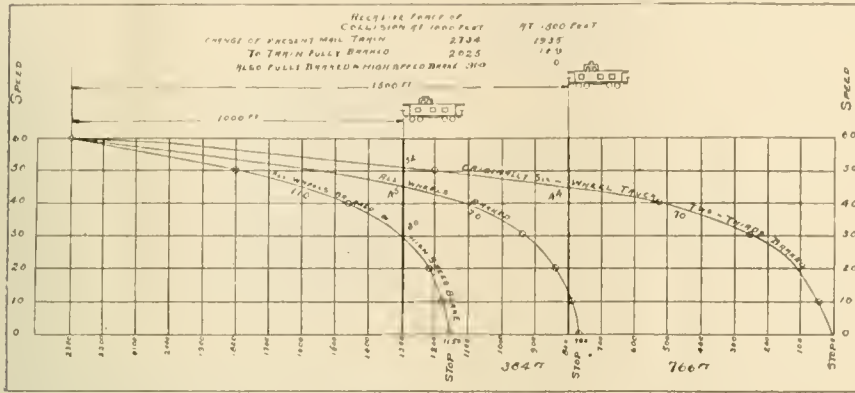

GRAPHIC COMPARISON OF STOPS MADE WITH LOW PRESSURE BRAKES AND HIGH SPEED BRAKES.

Courtesy of the Traveling Engineers Association.

CORRESPONDENCE.

An Air Pump Lifter.

A handy air pump lifter is to be seen in the Pittsburgh roundhouse of the Pennsylvania Lines West; it is made out of 3/4 in. round iron, and is of the form shown in the illustration. It is nothing more than an oblong frame with a notch for the lifting hook and what may be called a bale hanging from the upper cross bar.

When it is desired to lift an air pump from an engine, the frame is placed so that the lower cross bar is under the bottom head of the steam cylinder and the bale goes at the back of the valve chamber, then the hook from a differential pulley slipped into the notch completes the operation, and the pump can be swung free from the engine without any danger of falling, and the greater the pull the tighter the frame takes hold of pump, when on the ground the frame and bale almost automatically let go.

This arrangement has the advantage of doing away with the necessity of removing nuts from the top head of the

stead of the rest of the foundation brake gear.

When we passed from wooden to metal brake beams it was thought that the question of brake beams was settled; but unfortunately all metal brake beams are not as good as their name would imply, and really many are no better than the wood-

as shown in the diagram. The second stop (calculated) could have been made 760 ft. less, and the third stop (calculated) could have been made in 1,500 ft. less than the actual stop.

At the end of 1,000 ft. the train (not braking on the middle pair of wheels) was running at a speed of 52 miles per hour, and 44 miles per hour at 1,500 ft., stopping in 2,300 ft. The same train, had all wheels been braked, would have been running at a speed of 45 miles per hour at the 1,000 ft. mark, and 12 miles per hour at the 1,500 ft. mark.

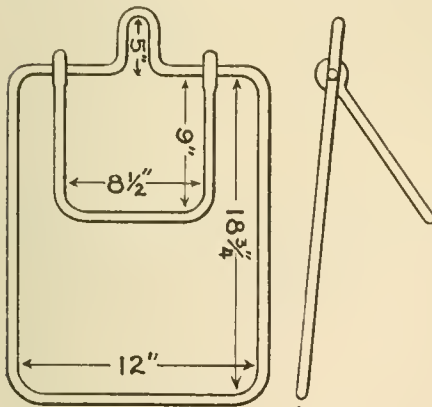

HANDY AIR PUMP LIFTER.

en brake beam, and, in fact, not as good. What we need to-day is a stronger brake beam, not only for passenger cars equipped with high speed brake, but for freight cars using the ordinary 70 lb. brake. Metal brake beams would be a good subject for some of the air brake clubs and the Air Brake Association to take up.

Advantage of Best Air Brakes.

The accompanying illustration shows the possible difference in stops, based on data secured from an actual stop of a fast mail train on one of our western lines.

As will be seen, there are three different stops. The first stop was actually made with the brakes on the outside

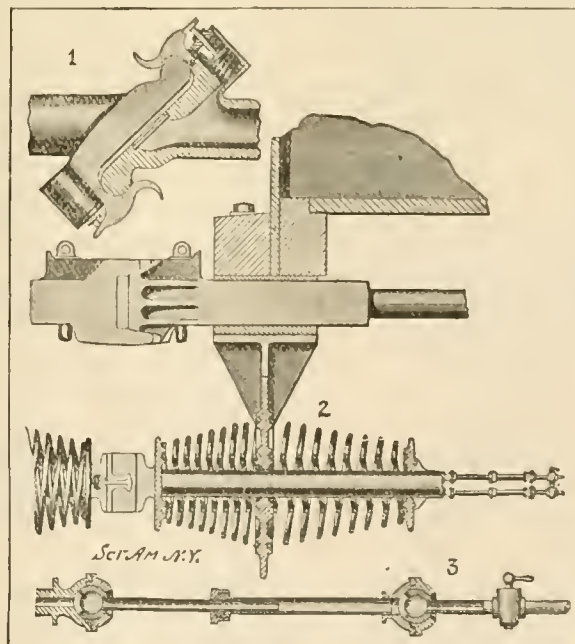

METALLIC LINE-PIPE COUPLING.

The third stop (calculated) on a high speed brake basis, would have been running at 30 miles per hour at the 1,000 ft. mark, and would have stopped at 1,150

pump and of temporarily bolting a U-shaped frame to the cover. The whole rig can be made by a blacksmith, and it has not bolts or nuts to shake loose or

strip, and when not in use it can be hung on a nail on the shop wall.

Air Pump Repairman's Rack Table.

Herewith are sketches of a rack for mounting and holding air pumps for repairs. Fig. 1 is a view taken from an elevated position, so as to show the plate on which the air pump may be placed; also the hinged joint and pivot on which the pump revolves.

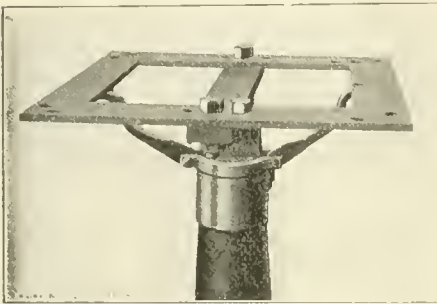

FIG. 1. AIR PUMP HOLDING RACK WITH PLATE IN HORIZONTAL POSITION.

Fig. 2 shows the rack in position for testing, with pipes ready for connection. All pipes are placed under the floor and a small trap door in the floor back of the rack can be raised and short pipes con-

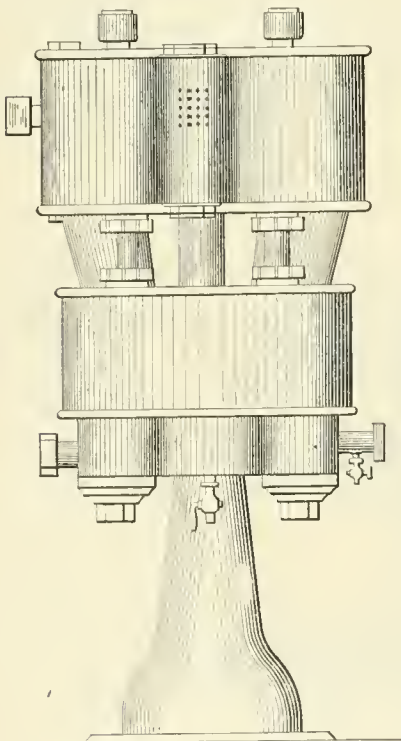

FIG. 4. NEW YORK AIR PUMP AND RACK IN VERTICAL POSITION.

nected from the pipes under the floor to the pump. When not in use the short pipes are removed and the trap door placed in position. We find that a rack that can be revolved and tilted makes a good rack.

Fig. 3 shows the rack with a No. 2 New York air pump in horizontal position, and Fig. 4 shows the same rack and pump in a vertical position.

This rack was designed and built by Mr. Frank Burns, division foreman, at Monett, Mo., and has been in use for six months, showing no weak points.

JOHN F. LONG,
R. H. Air Brake Insp'r, 'Frisco R. R.
Monett, Mo.

Automatic Train Line Pipe Coupling.

The great importance of an automatic train line coupling has been demonstrated more every year as the rolling stock increases and the demand for a more reliable and direct connection between cars is needed, which will tend to eliminate the dangerous work of going between the cars, and the saving of time in making up and setting out of trains at terminals. These difficulties have been overcome by the above mentioned ingenious device.

The ordinary flexible hose connection for line pipes of a train often burst under the pressure of air or steam, and to obviate such dangers, I have invented a flexible metallic coupling of simple and inexpensive construction. The coupling embodies means for utilizing the air or steam pressure to cause a tight connection between the coupling members.

As shown in Fig. 1 of my illustration, the coupling comprises two heads arranged on a transverse incline with each other. Each head is attached to a stem or drawbar having two ports opening through the head, one port being for the passage of the air through the brakes and the other for signaling purposes.

Pivotaly connected to each coupling head is a locking latch designed to engage with the other coupling head, as clearly shown in our illustration. The latch is provided with a curved or cam-shaped end, designed to be engaged by the approaching coupling head, thus swinging the latch to open position and permitting the heads to come together.

The latch is normally held in closed position by connection with a piston, which is acted upon by a coiled spring. The cylinder in which this piston operates is connected by a small port with the main port of the coupling, so that when air pressure is admitted to the coupling a portion will enter the cylinder, forcing the piston outward and causing the latch to tightly clamp the coupling together.

The drawhead of the coupling passes through an abutment ring depending from the car. Between this and a collar on the stem are two coil springs, and similarly two springs are coiled between the abutment ring and the collar on the opposite end of the stem. A telescoping pipe section connects each port with its respective train pipe. The sections have ball and socket connections with the stem

of the coupling, which permit perfect freedom of motion to the drawbar.

H. B. SCHRADER.

Alliance, Neb.

Flanged and Plain Brake Shoes.

Does not a flanged brake shoe hold better than the plain shoe without a

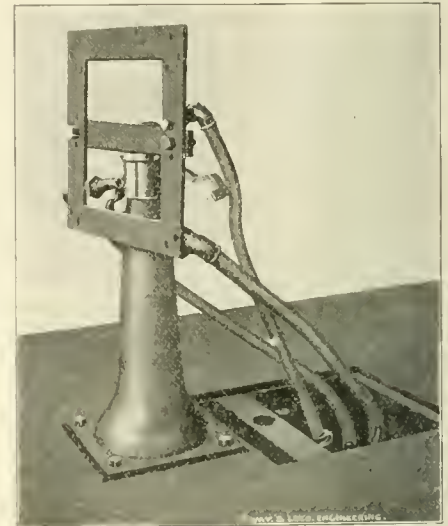

FIG. 2. AIR PUMP TESTING RACK IN VERTICAL POSITION, SHOWING PIPE CONNECTIONS.

flange? I believe the Air Brake Association at one time determined that a flanged shoe gave 30 per cent. more holding power than the plain shoe.

JAMES E. PALMER.

Middletown, N. Y.

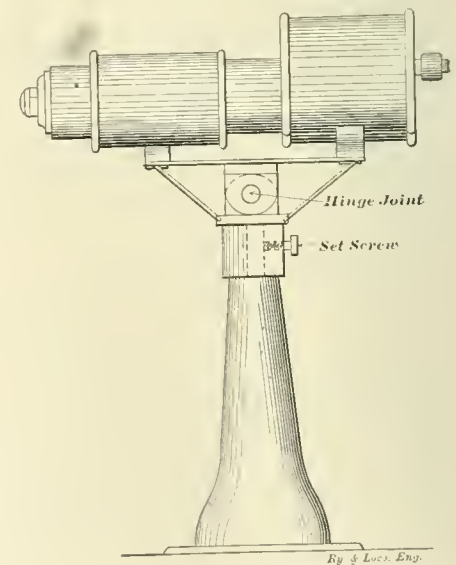

FIG. 3. NEW YORK AIR PUMP AND RACK IN HORIZONTAL POSITION.

[At one time in the early days of the Air Brake Association, one of its conventions discussed this subject, and decided that with the brake shoe then in service, the experience of some of the members had been that a flanged shoe gave about 30 per cent. greater retarda-

tion than the plain shoe. However, since that time the development of brake shoes has progressed to such a degree that nearly all roads are now using the flanged brake shoes on all passenger equipment cars, with the possible exception of the middle pair of wheels in the six wheel truck, where the plain shoe is used because of insufficient room for a flanged shoe. Several years ago, one road was obliged to remove all its flanged brake shoes, due to wheel sliding, and replaced them with the plain shoe; however, conditions seem to have changed, either in practice or in brake shoe mixture of metals, and nowadays it is an unusual occurrence to have a slid flat wheel with flanged brake shoes, unless very unfavorable weather and rail conditions prevail. Again, the flanged shoe trims down the sharp flange of the wheel and also that portion of the outer wheel tread which does not bear on the rail.—Ed.]

Don't Hang Up Packing Rings.

In visiting different shops, I notice that some air brake repairmen hang up their packing rings on hooks, strings, etc. I

passenger engine tenders? A.—A number of roads have already adopted the 1¼ in. hose as a standard for its passenger car equipment and locomotives and tenders, as well as its freight equipment,

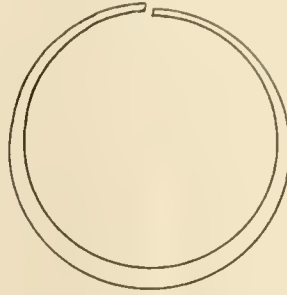

A PACKING RING DISTORTED BY HANGING UP ON A NAIL.

thereby using the 1¼ in. hose for all equipment except the pressure signal apparatus.

(75) C. E. S., Roanoke, Va., writes:

Some of our engines are equipped with a long and slender main reservoir, hung under the running board on one or both sides of the engine. Again some of the

valve. You said that the air between the check valve and the emergency valve was not disturbed in a service application and that air remains trapped in there. Now, when the triple is in release position, the air between the check valve and the emergency valve is train line pressure. What is that pressure called when the brake is applied? A.—The pressure between the check valve and the emergency valve may properly be termed train line pressure at all times, as it has not yet passed out of the train line, going either to the auxiliary reservoir or brake cylinder.

(77) R. E. B., Lehighton, Pa., writes:

I would like to ask you a question on the air brake. Now, for an example, if we had 70 lbs. train line pressure and the auxiliary reservoir charged to 70 lbs., how does the check valve stand? Is it on its seat or is it up? A.—The check valve will be seated. In fact, the normal position for this check valve is the seating position, no matter what the pressure is below and above the check valve, due to the spring between the check valve and the emergency valve. The check valve

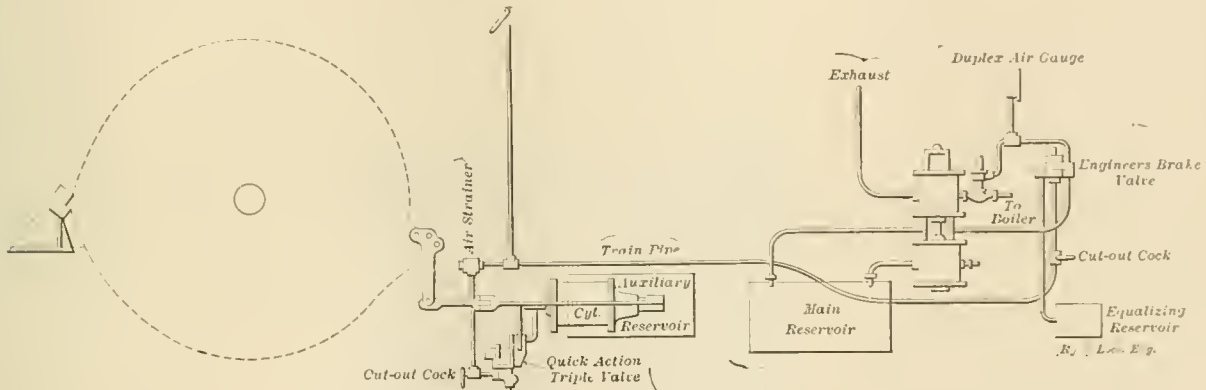

NOVEL APPLICATION OF THE AUTOMATIC BRAKE TO A MINE ENGINE HOISTING DRUM.

have found this to be a bad practice, inasmuch as the weight of the suspended ring will spring the ring out of its true circle, necessitating considerable filing away of the ring to make it fit in the cylinder. This is especially true of governor, triple valve and equalizing piston rings.

For the small rings I have had tin boxes made slightly larger than the ring, and they are laid flat in the box. The large air pump rings are laid on shelves in the same manner. By this means the rings retain their original circle, and are much better and more readily fitted. An accompanying sketch shows the result of a hung up ring.

J. A. JESSON,

A. B. Repr'n, L. & N. R. R.

Corbin, Ky.

QUESTIONS AND ANSWERS

ON THE AIR BRAKE.

(74) W. E. W., Cincinnati, O., asks: Why would it not do to use a 1¼ in. air hose on passenger cars and also on

engines have one long slim main reservoir under the running board and a short stubby reservoir about the shape of a hogshhead under the barrel of the boiler. Which style of reservoir is the better one? A.—The long and narrow reservoir, if it be of sufficient capacity to hold the necessary volume of air, is preferable to the short and stubby reservoir, as better opportunity is presented for the air to cool before it passes to the brake valve and back into the train pipe. The long and slim reservoir has a greater radiating surface, which permits a better cooling of the air, and consequently depositing of the moisture in the main reservoir before the air passes back into the train pipe. The short, stubby reservoir will retain the heat, as it does not have sufficient area exposed to cool the air.

leaves its seat only when the air pressure on the under side of the valve is greater than the air pressure on the upper side, plus the weight of the valve, plus the spring tension.

(78) J. McS., Syracuse, N. Y., writes:

I observe that some of the levers bottom against the end of the slot of the strut in the brake beam, as soon as the lever gets out of the straight line, and gets a little angle to it. This isn't right, is it? A.—Possibly this is due to the strut being too shallow in length and not allowing the brake lever to assume a reasonable variation in angle, far away from the straight line. It may be that the brake levers are of an increased width as advocated by the Master Car Builders for high speed brakes. This might be the case, and especially so if the brake beam is of the older type, and whose strut was not designed for the greater depth required by the high speed brake lever.

(76) R. E. B., Lehighton, Pa., writes:

Last month there was a question in the RAILWAY AND LOCOMOTIVE ENGINEERING about the check valve and the emergency

A Table of Principal Alloys.

A combination of zinc and copper makes bell metal.

A combination of copper and tin makes bronze metal.

A combination of antimony, tin, copper and bismuth makes britannia metal.

A combination of copper and tin makes cannon metal.

A combination of copper and zinc makes Dutch gold.

A combination of copper, nickel and zinc, with sometimes a little iron and tin, makes German silver.

A combination of gold and copper makes standard gold.

A combination of gold, copper and silver, makes old standard gold.

A combination of tin and copper makes gun metal.

A combination of copper and zinc makes mosaic gold.

A combination of tin and lead makes pewter.

A combination of lead and a little arsenic, makes sheet metal.

A combination of silver and copper makes standard silver.

A combination of tin and lead makes solder.

A combination of lead and antimony makes type metal.

A combination of copper and arsenic makes white copper.

Swiss Bridges.

When the tourist has taken his departure from Lucerne, he will remember the two mediæval wooden bridges which span the Reuss.

The first of these old bridges nearest the lake is the Kapellbrücke, which, built in 1333, has been in constant use up to the present day. This bridge runs diagonally across the clear, emerald-green river, and is built entirely of wood.

Many changes have taken place since that day. Old Lucerners, clad in coats of mail, and armed with their redoubtable two-handed swords and battle axes, have clanked across this bridge, and it could recount strange tales of noble knights and ladies fair who, have trod its ancient boards, could it but speak.—From "Ancient Bridges of Lucerne," by Charles B. Wells, in *Four-Track News* for September.

Too Smooth.

Mr. Old Polisher.—What's the matter, Mr. Van? I hear you have parted with Mr. Oleo, your new advertising solicitor. He has the reputation of being slick.

Mr. Van.—Slick was no name for Oleo's manner. But he is not a success. He would begin a call by flattering patrons to such an extent that they were afraid he intended borrowing money of them, and he seldom got the length of talking business.

A Positive Oil Delivery.

BY J. A. BAKER.

No doubt the readers of RAILWAY AND LOCOMOTIVE ENGINEERING will be interested to know that a positive oil delivery device, one that does get the oil to the cylinders of our high pressure engines under any and all conditions, has been invented. Having seen it put to a practical test under very severe conditions, giving positive results, it gave me no opportunity whatever for criticism. Not only does it insure to the operator perfect lubrication, greater horse power and a decrease in coal consumption, but it also reduces the consequent wear of the valve gear and eliminates the hot eccentric, traceable to defective lubrication.

Five of our great trunk lines, whose names I am requested to withhold for the present, are giving it a most severe test, and so gratifying are the results so far

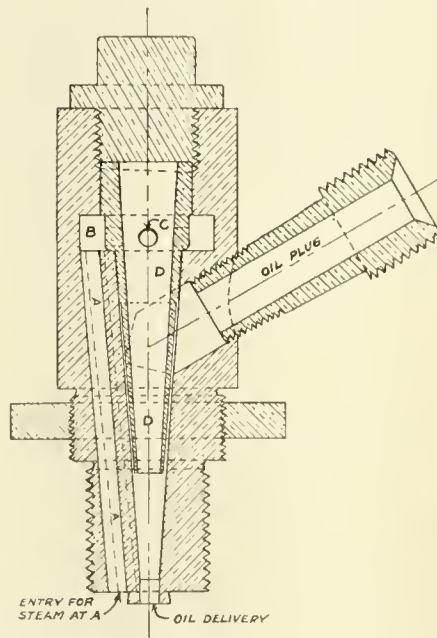

POSITIVE OIL DELIVERY DEVICE.

that it receives their unqualified approval. Some engineers have volunteered to purchase these plugs themselves rather than have them removed.

On one line where necessity compelled them to examine and renew worn or broken valve and cylinder packing on a compound engine every 10 days, it was found possible to run this engine—equipped with the Tuma Suction Valve Plug—since June 1 without any renewal or attention to packing rings. A prominent operating official states that on a six days' trial with these plugs they have made over a dollar per day in the saving of coal alone.

No alterations in the oil pipes are necessary; the suction plug is secured to the chest and oil pipe in the same manner that the present plug is. As will be seen from the illustration, this oil plug consists of a delivery nozzle, a steam chamber and a cap nut to hold the nozzle in place. The three $\frac{1}{8}$ in. passages marked A, of which

only one is seen in the cut, permit steam to flow up into the steam chamber B. It then enters five $\frac{1}{8}$ in. passages at C, producing a downward pressure in nozzle D D. Actual tests proved that the pressure in chamber B was greater than the pressure in the oil pipe, caused an induced current toward the chest, entrained the oil from the pipe and forced it into the steam chest. The holdup of oil in the pipe with this patented device, which we know takes place with the ordinary plug, has been entirely eliminated.

Mr. Stone on Electricity vs. Steam.

The Utica, N. Y., *Observer* gives an account of an interview with Mr. Warren S. Stone, grand chief engineer of the Brotherhood of Locomotive Engineers, in which electricity vs. steam was the topic discussed.

Mr. Stone is reported to have said in effect that for suburban traffic electricity as a motive power will soon be here. Electricity permits more trains and faster trains to be run than is possible with steam, but when it comes to long distance hauls there are, of course, more problems to be met.

If a steam locomotive breaks down it affects that motor unit only, but if the motive power of an electric road is put out of commission everything on the road or at least on a very considerable section of it comes to a standstill. The third rail seems to be an essential feature of an electric road's equipment, and the stringing of these heavily charged rails over a wide section of country involves great possibilities of danger unless some better way of protecting them is devised than any now in use. Mr. Stone gave examples of some long distance electric roads already in existence.

The general passenger agent, in advertising his one commodity, travel, is incidentally advertising all other commodities. Increase of travel means increase of every business under the sun. First, the people who travel spend money for better clothing, for impedimenta of all varieties, for literature about the places they are to visit. When likely to live better than when at home—or at least to spend more money for food, lodging, side trips and comforts. Travel teaches them new ways of being comfortable, and when they return home they are practically certain to enlarge their scheme of living according to new, liberal views they have acquired. Travel is an education. It is more directly educational than the schools, and the scholars are more receptive and quicker at getting their lessons. Therefore, the general passenger agent, in advertising his road—or, better yet, all roads—is a general benefactor, and those narrow enough to oppose his efforts are standing in their own light and the light of several million more of us.

The Owner of Many.

The matter of selling a big touring car to James B. Brady appeared to be an event of extraordinary importance in New York City last month. The office of the *Automobile Magazine* is a place where many



Mr. Brady and Mr. Sinclair in Automobile.

people love to linger, seeking for news or imparting information about what is going on in the automobile world. One day a visitor came in bathed in smiles that broke through the sweat of the day's humidity and whispered the intelligence that he "had just sold a Mercedes to 'Diamond Jim.'" Before the day closed two other visitors happened in and told the same joyful

tale of effecting a sale of the same kind of motor car to the same gentleman.

I was aware that my old friend Brady had taken very enthusiastically to automobiling since his ship of fortune had come in, but the purchase of three expensive foreign cars within one day seemed a bit too much for even so generous a patron of automobiling as Mr. Brady, so I sallied forth in search of the truth. I found my old friend undergoing the simultaneous attentions of a barber and of a bootblack while eating a light lunch, an example of time utilizing thoroughly characteristic of the man; but with it all he was ready to receive me with his old-time cordiality. He confessed to the purchase of a new Mercedes and invited me to ride out with him, an invitation I readily accepted.

Mr. Brady is owner of half a dozen automobiles, and uses them more for the purpose of giving pleasure to his friends than for his own amusement, which is another characteristic of the man, who is one of my oldest friends in New York and for whom I entertain the warmest regard for his many fine qualities. Our acquaintance began away back in the days when I was a very humble sub-editor and Brady was a railroad man. Our first meeting was at a railroad club, and I have never forgotten the cordial invitation I received to "come and see us and we will give you all the pointers we can about what is going on among railroad men." Mr. Brady proved as good as his word and later on he gave me many pointers that were worked into articles.

Soon after our first meeting he went

into the railroad supply business, in which he made a grand success from the start through the forces of native energy and the capacity to make and hold friends, which he possesses in an unusual degree. His surplus earnings Mr. Brady put into enterprises which his keen judgment decided upon as sound, so he is now a rich man with no one to thank but himself and well able to buy two or a dozen automobiles, just as inclination tempts him.

Like most men, Mr. Brady has a hobby which, in his case, is the collecting of diamonds. While jewelry seldom adorns his person, Mr. Brady is said to have an almost unrivaled collection of diamonds which he sometimes shows to his friends. On this account he is quite often differentiated from others of his family name by the prefix of his hobby. Another of Mr. Brady's desires is to be the best dressed man in town. In this he seems to achieve the same decided success which he has reached in other directions.

James B. Brady is a big hearted, generous man, and the greatest pleasure he derives from the possession of automobiles, horses and other mediums of entertainment is in lending them to his many friends, and automobiling will gain much from the interest Mr. Brady has



MR. JAMES P. BRADY.

taken in it.—*Angus Sinclair in Automobile Magazine.*

New Method of Bronzing Iron.

The following method is successful in producing a bronzelike surface which practically prevents rust. All the methods

as yet known for producing a bronzelike surface, by rubbing over the surface of the iron an acid solution of copper or an iron solution, letting it dry in the air, brushing off the rust produced in this way, and an abundant repetition of this method, give a more or less reddish brown crust or rust on the iron body. Objects formed of iron can easily be covered with copper or brass by dipping them in the requisite solution, or by submitting them to the galvanic method. The surface so prepared, however, peels off in a short time, by exposure to moist air in particular.

By the method given below it is possible to cover iron objects, especially such as have an artistic aim, with a fine bronze like surface; it resists pretty satisfactorily the influence of moisture, and one is, moreover, enabled to apply it to any object with great ease. The clean, polished objects are to be exposed to the action of the vapors of a heated mixture of hydrochloric acid and nitric acid, in equal portions, for from two to five minutes; they are not to be shifted, and the temperature may range from 572° to 662° Fahr. The heating is continued so long that the bronze like surface is well developed on the surface of the objects. After the objects have cooled they should be well rubbed down with vaseline and again heated until the vaseline begins to decompose. When again cold they should be a second time treated with vaseline in the same way.

If the vapor of a mixture of the two concentrated acids is allowed to act on an iron object in this manner, a light reddish brown tone is developed. If some acetic acid be mixed with the two acids, and the vapor of all the acids together be allowed to act on the metallic surface, a fine bronze yellow color can be obtained. By using different mixtures of these acids every tint, from a dull red brown to a light brown, and from a dull brownish yellow to light brown yellow, can be produced on the surface of the iron. In this way some T-rods for iron boxes were covered with a bronze like surface, and at the end of ten months, although exposed during the whole time to the action of the acid fumes of a laboratory, they had undergone no trace of any change.

"Let reverence of law be taught in schools and colleges, be written in primers and spelling books, be published from pulpits and proclaimed in legislative houses, and enforced in the courts of justice—in short, let it become the political religion of the nation."—*President Lincoln.*

Volume of Air Required to Sustain Combustion.

In the course of a discussion on ash pans at last Master Mechanics' Convention, Angus Sinclair said:

I shall make a statement, upon which I should like to have the views of Professor Goss. During the last year that I was running a locomotive, I was writing articles on locomotive engine running for a publication. I was paying a great deal of attention to the work of the locomotive in every detail for the purpose of putting items relating to them into my articles, and among the features I paid special attention to was the subject of firing and the way that steam could be maintained most easily with the least supply of fuel. I discovered very soon that light firing was the best in every respect for the engine doing fairly light work, but I also found that the engine very often would not steam with a light fire and that it would steam better with a considerably heavier fire. In experimenting with the variables of that problem, I found that the engine would steam more satisfactorily with the dampers closed, and until the fire began to get dirty I was in the habit of running with the dampers closed. Of course, there was a good deal of opening at the sides of the ashpan and air was admitted to the extent it was necessary, anyhow, because if an engine steams better with

the dampers partly closed. Professor Goss, with his means of ascertaining the exact supply of air necessary, is probably in a position to say how large these openings should necessarily be for certain grates; but for myself I am

coal when I took charge of the machinery on the road. They were operated through a section of the country where our right of way was very inflammable for about five months in the year, cotton platforms at an average of about every six miles along the line of 240 miles of road. We were compelled to drop our dampers in passing cotton platforms. The locomotives I found using coal, while they had a thin fire, for the first forty or fifty miles, burning perhaps three tons of coal in that distance, you could run very nicely with both dampers down, and for 100 miles, or until the fire began to get dirty, then you could run with the front damper up and the back damper down. In going over the division, 162 miles, an 18 inch cylinder ten-wheel engine would burn about seven tons of coal.

We changed the engines into oil burners with an ashpan that is not an ashpan, but an arch with four air openings four inches square, no dampers. Of course, we got no dirty fires with oil and the engines we thought would do better by giving them more air. We increased the air openings to six inches square and they didn't do so well. Then we tried reducing the air supply and we are now operating the same engines with one opening in the arch, which is made of brick, for an ashpan four inches square, and the engines steam very free without any smoke at

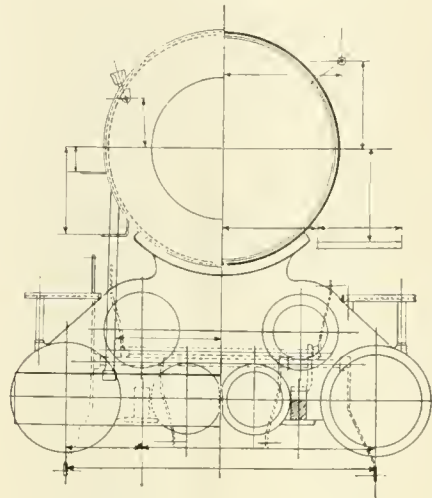

FRONT VIEW OF BALANCED COMPOUND HIGH AND LOW PRESSURE CYLINDERS ON LOWER HORIZONTAL LINE. PISTON VALVES ABOVE.

positive with certain engines that they require less fuel and steam better with the dampers partly closed—that means that the air supply is restricted. In another respect it was better for the engines—they took the supply of air necessary, there was no rush of cold

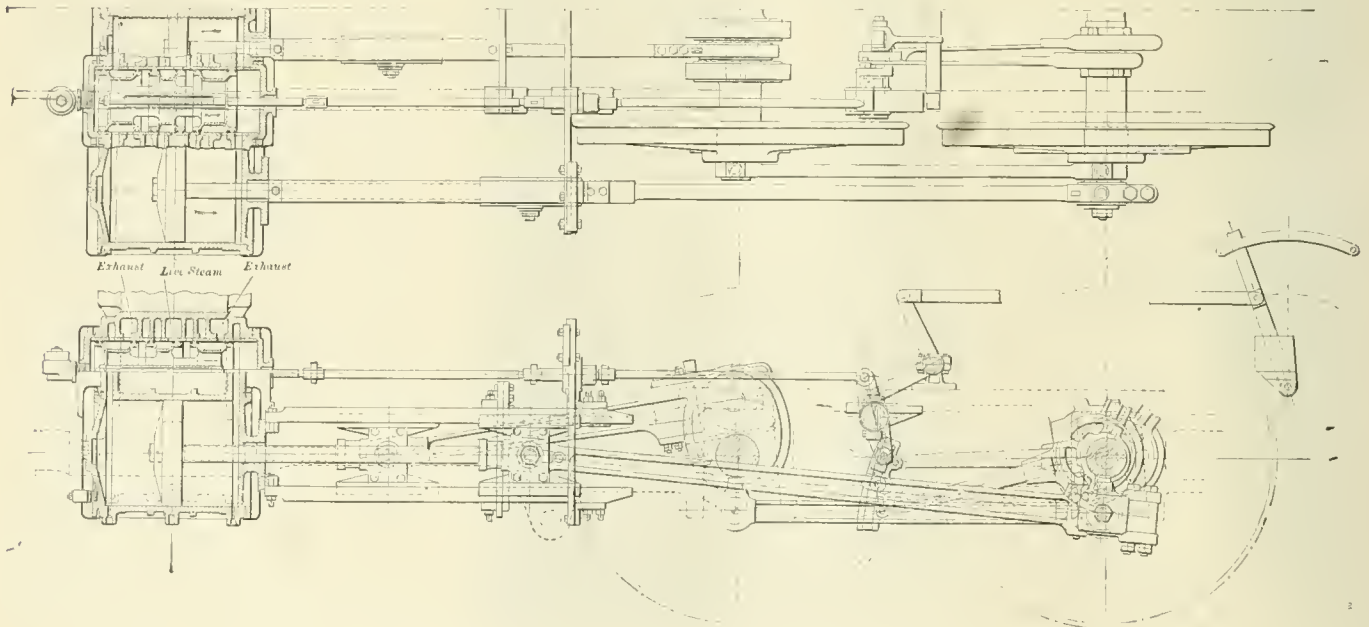

PLAN OF BALDWIN FOUR-CYLINDER BALANCED COMPOUND SHOWING CRANK AXLE.

Fig. 6 Loco. Eng.

the dampers closed than it does when they are open, it is consuming fuel to the best advantage.

It has struck me in all this discussion about the openings in the ashpans that the supply of air is, as a rule, quite beyond what is necessary, and that it would often be an advantage to run with

air through the side of the sheets, and the fire boxes were peculiarly free from side sheet leakage.

Mr. Mord Roberts said: My opinion is from the use of oil in locomotives, that they do not require very much opening in our ashpans. We are now operating locomotives that were burning

all except when they clean the flues, and that is only soot, and after about three or four exhausts of the engine after the sand is introduced into the fire box there is absolutely no smoke. So that I am inclined to believe that if we will in our coal burners keep our fire so that the air can pass through

the grates freely, we will get plenty of air into the ashpan with the dampers closed. We do not make ashpans air tight or water tight.

Four Cylinder Balanced Compound for the "Q."

The Baldwin Locomotive Works, of Philadelphia, have recently supplied the Chicago, Burlington & Quincy Railway with some fast passenger four cylinder balanced compounds of the Atlantic type.

The cylinders are 15 and 25x26 ins. and the driving wheels are 78 ins. in diameter. The arrangement of cylinders and valves shown in our illustrations reveals the fact that the horizontal center lines of the high and low pressure cylinders coincide, and the valve is placed in such a way that when steam leaves the high pressure cylinder it passes up to the valve and down to the low pressure cylinder.

The valve is of the piston type actuated by indirect motion and has outside admission for the high pressure cylinders.

on the top quarter, and allowing for the angularity of the connecting rods in these positions, the pistons will each be about in the mid-stroke position, and as the engine moves forward the pistons on the same side will move in opposite directions. The counterbalances on this engine present an interesting feature, the counterweights on the forward wheels balancing the cranks in the axle.

The boiler is a wagon top with wide fire box and measures 64 ins. diameter at the smoke box end. The dome course is 72½ ins. inside diameter. The back and throat sheets are sloped and the crown and roof sheet are also sloped. The heating surface amounts to 3,223.17 sq. ft. in all, of which 3,050.5 sq. ft. is in the tubes. There are 271 tubes 2¼ ins. diameter and 19 ft. long. The grate area is 44.14 sq. ft.

The tank is of the ordinary U-shaped type carried on steel channel frames. The capacity of the tank is 6,000 U. S. gallons of water. The tender truck wheels are 37¼ ins. in diameter and the journals are

The Annual Ring in Trees.

The annual rings in trees exist as such in all timber grown in the temperate zone. Their structure is so different in different groups of timber that, from their appearance alone, the quality of the timber may be judged to some extent. For this purpose the absolute width of the rings, the regularity in width from year to year and the proportion of spring wood to autumn wood must be taken into account. Spring wood is characterized by less substantial elements, the vessels of thin walled cells being in greater abundance, while autumn wood is formed of cells with thicker walls, which appear darker in color. In conifers and deciduous trees the annual rings are very distinct, while in trees like the birch, linden and maple, the distinction is not so marked, because the vessels are more evenly distributed. Sometimes the gradual change in ap-

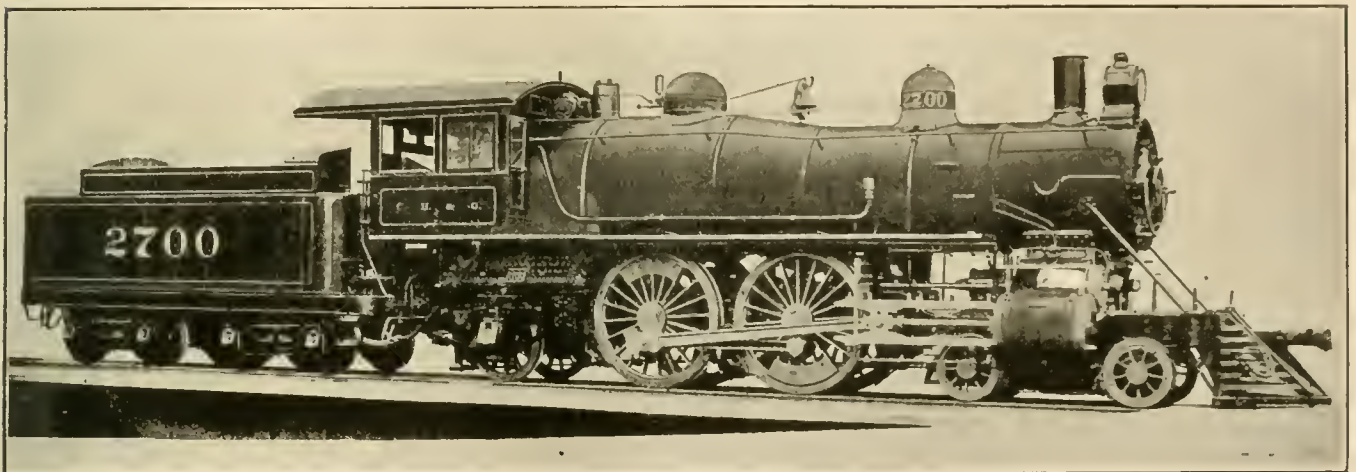

FAST PASSENGER FOUR-CYLINDER BALANCED COMPOUND FOR THE C., B. & Q.

F. H. Clark, Supt. of Motive Power.

Baldwin Locomotive Works, Builders

The high pressure exhaust passes into the interior of the valve at one side and finds its way to two ports or openings in the other side, which feed the low pressure cylinders, and the low pressure exhaust passes through the valve to the stack.

The cylinders and main axles are so arranged that the high pressure pistons drive on the leading axle, which is cranked, the cranks being set on the quarter as usual. The low pressure pistons drive on the outside crank pins of the rear wheel, as is usual with the 4-4-2 type of engine. The low pressure piston rod is longer than usual and it does not go entirely into the cylinder at each stroke. A glance at our half-tone illustration will show the low pressure crosshead apparently near the back end of the guides, while in reality it is in mid stroke. The high pressure piston rod and crosshead conform to usual practice. When the outside crank pin on the right side is on the bottom quarter, the inside crank axle pin on the same side is

5x9 ins. A few of the principal figures are as follows:

Boiler—Material, steel; thickness of sheets, ¾ in. and 1½ in.; working pressure, 210 lbs.; staying, radial.
 Fire Box—Material, steel; length, 66¼ ins.; width, 66¼ ins.; depth, front, 70¾ ins.; back, 68¾ ins.; thickness of sheets, sides, ¾ in.; back, ¾ in.; crown, ¾ in.; tube, ½ in.
 Water Space—Front 4 ins.; sides, 4 ins.; back, 3 ins.
 Driving Wheels—Journals, main, 10 x 10½ ins.; others, 9 x 12 ins.
 Engine Truck Wheels—Front, dia., 33 ins.; journals, 6 x 10 ins.
 Trailing Wheels—Dia., 48 ins.; journals, 8 x 12 ins.
 Wheel Base—Driving, 7 ft. 3 ins.; rigid, 15 ft. 6 ins.; total engine, 30 ft. 2 ins.; eng. and tend., 57 ft. 7½ ins.
 Weight—On driv. wheels, 101,210 lbs.; truck front, 52,630 lbs.; trailing wheels, 40,200 lbs.; total engine, 203,040 lbs.; eng. and tend., about 318,000 lbs.

Most of the pioneer locomotive builders devoted themselves to inventing new forms of locomotives. Mr. Baldwin strove to improve details.

pearance of the annual ring from spring to autumn wood, which is due to the difference in its component elements, is interrupted in such a manner that a more or less pronounced layer of autumn wood can apparently be recognized, which again gradually changes to spring or summer wood, and then gradually finishes with the regular autumn wood. This irregularity may occur even more than once in the same ring, and this has led to the notion that the annual rings are not a true indication of age; but the double or counterfeit rings can be distinguished by a practiced eye with the aid of a magnifying glass. These irregularities are due to some interruptions of the functions of the tree, caused by defoliation, extreme climatic condition or sudden changes of temperature. The breadth of the ring depends on the length of the period of vegetation; also when the soil is deep and rich, and light

has much influence on the tree, the rings will be broader. The amount of light, and the consequent development of foliage, is, perhaps, the most powerful factor in wood formation, and it is upon the proper use of this that the forester depends for his means of reg-

I to 3; that is, for 100 lbs. of compressor pressure the tester will compress the air in the high pressure cylinder up to 300. B is the exhaust pipe to the atmosphere, and E to the testing gauge. In Fig. 1 the piping and cylinders are shown under the work bench out of harm's

line. A taper air connection, easily applied and removed, connects the forge with the air supplied from the blower, when the forge is standing as shown. It is used for heating frames and like heavy work, and when the frame is embedded in the banked up coal, a couple of fire bricks are placed on top and the heating is carried on to the required temperature.

When it is desired to place the heated frame on the anvil, the fire bricks are removed from the top and the helpers insert a couple of levers in sockets in the counter weights and lower the forge steadily down, it sliding down along the four upright guides attached to the bed frame. In this operation the fire is not torn down and half of it swept off the floor. The frame comes squarely out as the forge sinks down. It can then be swung onto the anvil without any loss of time, as no lifting of the frame is necessary, and if a second heat is required it can be swung back over the fire and the forge raised, thus again embedding it in the unbroken bank of coal. Economy of time, economy in the use of fuel and neatness and precision of operation are the features which strike an observer of this drop forge when it is in operation. Our engraving is made owing to the courtesy of Mr. J. J. Reading, master mechanic of the McKees Rocks shops.

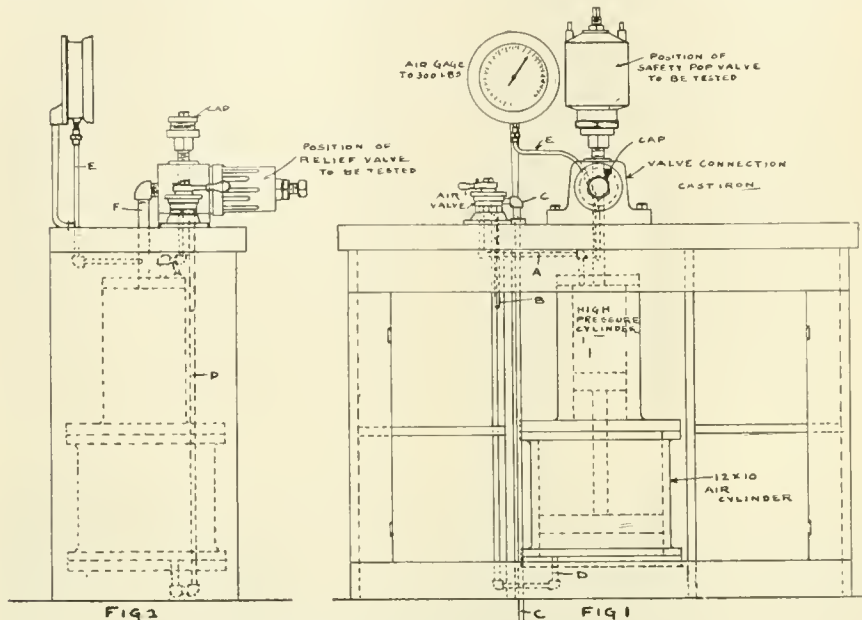

DEVICE FOR TESTING POP AND RELIEF VALVES.

ulating the development and quantity of his crop.

An Excellent Shop Kink.

In this issue we present to our readers a line drawing and description of a most useful shop kink, designed by the Boston & Maine Railroad, for testing pop and relief valves. The device is already in operation in the B. & M. shops at Keene, N. H., and giving entire satisfaction. It obviates the necessity of installing and maintaining an extensive steam plant for this purpose, and its simplicity is apparent, while it costs nothing to maintain, the only outlay being for its construction. It will be heartily welcomed by the man whose duty it has been to crawl on top of a boiler to regulate the safety valves under pressure.

Fig. 1 shows a front view of the testing plant, Fig. 2 a side view. By following the letters in Fig 1 we find that the air, which is taken from a compressor plant, enters the pipe at C and passes up into the rotary regulating valve controlled by the operator. From there it passes through pipe A to the top of the high pressure cylinder. Communication with this cylinder is now closed and communication with the bottom of the low pressure cylinder is obtained by placing the rotary valve in position to admit the air to pipe D. The differential piston is forced upward and the imprisoned air in the high pressure cylinder is further compressed to any desired degree up to 300 lbs. The proportion of power is as

way. The valve connection shows a pop valve in position for testing, also a cap on the front which is to be removed when attaching a steam chest or cylinder over-pressure valve as shown in Fig. 2, in which case a plug cap is substituted in the top in place of the pop valve. Pipe F, Fig. 2, connects H. P. cylinder with pop valve chamber. The plant is very simple and compact and will prove its worth to any one who wishes to adopt it.

A Handy Drop Forge.

An ingenious drop forge designed by Mr. McCaslin, foreman blacksmith of the

The Sea'll No Be Verra Deep.

"I was spending a few days in Strathavan, Scotland," said Robert B. Mantell, the actor, recently. "At the inn where I was stopping lived an old couple who were preparing to visit the United States. Naturally enough, they questioned me at some length about the trip, and the old gentleman was anxious to know if it was very dangerous to cross the ocean. I assured him that it was not at all hazardous, although it was often very rough. His sister listened intently, and

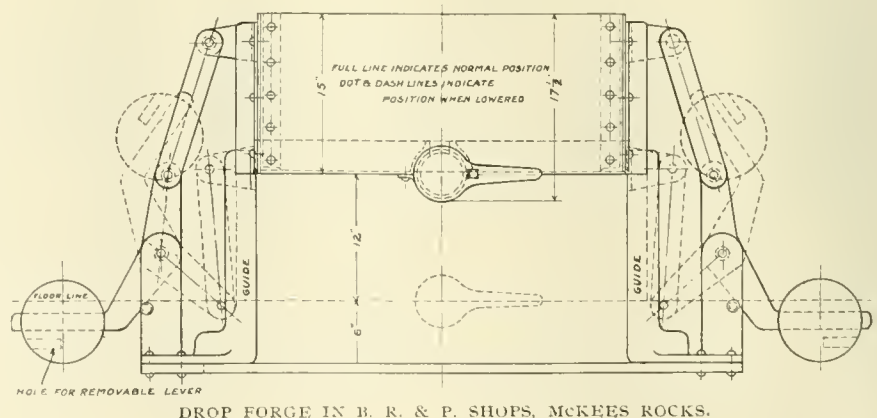

DROP FORGE IN B. R. & P. SHOPS, MCKEES ROCKS.

McKees Rocks shops of the Pittsburgh & Lake Erie Railroad, is here illustrated.

The forge is shown in its normal position, standing about 12 ins. above the floor

then remarked with a sigh of contentment: 'Aweel, aweel, it's been a gay dry summer and I think the sea'll no be verra deep.'"

Of Personal Interest.

Mr. Mord Roberts has resigned the position of superintendent of machinery of the Kansas City Southern.

Mr. Henry Bube, boilermaker, at Weatherly, has been promoted to foreman boilermaker at Weatherly.

Mr. Henry Smink, foreman boilermaker, at Weatherly, has been promoted to foreman boilermaker at East Buffalo shops.

Mr. C. E. McLaughlin, of Willmar, Minn., has been promoted to the position of traveling engineer on the Great Northern.

Mr. Luke Murray has been appointed traveling engineer on the Detroit & Mackinac Railway, with headquarters at East Tawas, Mich.

Mr. L. D. Gillett has been appointed master mechanic, Pocahontas Division of the Norfolk & Western Railway, vice L. P. Ligon, transferred.

Mr. Harry Rhodes has been appointed roundhouse foreman on the Southern Railway, at Louisville, Ky., vice Mr. J. H. McDermet, promoted.

Mr. Webb C. Ball has been appointed general time inspector on the Chicago, Rock Island & Pacific Railway. His headquarters will be in Chicago.

Mr. J. M. Thomas has been appointed general foreman of the West Roanoke shops of the Norfolk & Western Railway, vice L. D. Gillett, promoted.

Mr. L. P. Ligon has been appointed master mechanic of the Eastern General Division of the Norfolk & Western Railway, vice H. T. Herr, resigned.

Mr. Henry Comstock has been appointed to the new post of division master mechanic on the New York, New Haven & Hartford, with headquarters at New London.

Mr. Seth Hanchett has been appointed road foreman of equipment on the Dakota division of the Chicago, Rock Island & Pacific Railway, with headquarters at Estherville, Ia.

Mr. J. H. Dermet, roundhouse foreman of the Southern Railway, at Louisville, Ky., has been promoted to be general foreman at the same point, vice Mr. W. G. Anderson, resigned.

Mr. A. T. Kalas, formerly of the Railway Appliance Company, of Chicago, has recently taken charge of the railway supply department of Berger, Carter & Company, of San Francisco.

Mr. E. U. Joy, formerly assistant air brake inspector on the New York, New Haven & Hartford, has recently been

made air brake inspector, vice Mr. E. W. Allen promoted.

Mr. Geo. Hahn, foreman boilermaker at East Buffalo, on the Lehigh Valley, has been promoted to the position of foreman boilermaker of the Lehigh at their main shops in Sayre, Pa.

Mr. E. W. Allen, formerly air brake inspector on the New York, New Haven & Hartford, has been appointed road foreman of engines, with office at New Haven, vice Mr. H. Oviatt, promoted.

Mr. James W. Hill, master mechanic on the Peoria & Pekin Union Railway, at Peoria, Ill., resigned his position about the middle of last month. Mr. Hill has been with that road for the past eighteen years.

Mr. H. C. Woodbridge, inspector at Schenectady for the American Locomotive Company, has accepted and been appointed general foreman for the Delaware, Lackawanna & Western Railway, at Elmira, N. Y.

Mr. A. B. McHaffie, formerly locomotive foreman, at Moncton, N. B., on the Intercolonial Railway of Canada, has been promoted to be division master mechanic at the same point and on the same road.

Mr. W. L. Larry, formerly road foreman of engines, has been promoted to be master mechanic of the Taunton Division of the New York, New Haven & Hartford, with office at Taunton, Mass., vice Mr. A. W. Twombly, resigned.

Mr. H. Oviatt, formerly general road foreman of engines on the New York, New Haven & Hartford, has been promoted to the position of division master mechanic at New Haven, Conn. This is a newly created position.

Mr. E. E. Watson has been appointed division freight and passenger agent for the Wisconsin, Minnesota and Pacific division of the Chicago Great Western Railway, with headquarters at Red Wing, Minn., vice R. H. Heard, promoted.

Mr. S. C. Wolfersberger, formerly road foreman of engines on the Connellsville division of the Baltimore & Ohio, has been appointed trainmaster of the New Castle division of the same road, vice Mr. P. J. Raidy, assigned to other duties.

Mr. Jas. McDonough, formerly master mechanic on the Chicago, Rock Island & Pacific, at Dalhart, Tex., has been transferred as master mechanic to the Oklahoma & Southern division of the same road, with headquarters at Chickasha, I. T.

Mr. T. E. Miller, formerly assistant road foreman of engines on the Connells-

ville division of the Baltimore & Ohio Railroad, has been appointed road foreman of engines on the same road and division, vice Mr. S. C. Wolfersberger promoted.

Mr. W. H. Whiteside, general manager of sales of the Allis-Chalmers Co., has been appointed general manager of sales of The Bullock Electric Manufacturing Co. He will have entire charge of the sales department of both the Allis-Chalmers and Bullock organizations.

Mr. C. D. Pettis, formerly general foreman of the car department of the Illinois Central, at the Burnside, Ill., shops, has been appointed superintendent of the car department of the St. Louis & San Francisco Railroad, with office at St. Louis, Mo.

Mr. C. T. Sheldon, formerly roundhouse foreman at Providence, has been promoted to be master mechanic of the Worcester Division of the New York, New Haven & Hartford Railroad, with office at Valley Falls, R. I., vice Mr. L. M. Butler, resigned.

Mr. J. C. Howe, formerly roundhouse foreman at the South Boston freight terminal, has been promoted to be master mechanic of the Plymouth Division of the New York, New Haven & Hartford, with office at South Boston, Mass., vice Mr. S. P. Willis, resigned.

Mr. A. W. Twombly, who a short time ago retired from the position of master mechanic on the New York, New Haven & Hartford, at Taunton, Mass., was presented by the motive power employees at that point, with a handsome diamond ring as a token of regard and esteem.

Mr. S. P. Willis, who recently resigned his position of master mechanic of the Plymouth Division of the New York, New Haven & Hartford, was, on the occasion of his departure, presented with a gold headed cane and diamond ring by the employees in the motive power department of the road.

Mr. Edward J. Neville has been appointed engine house foreman at Tupper Lake Junction on the Mohawk and Malone division of the New York Central. Mr. Neville was formerly an engineer on the M. & M., and has the requisite ability, energy and push to make him a success in his new position.

Mr. M. J. Butler, chief engineer of the Montreal Locomotive and Machine Company, has been appointed chief engineer to the Canadian Transcontinental Railway commission. He will have charge of the construction of the government railway

which will eventually be part of the Grand Trunk Pacific.

Mr. Ira A. Moore, whose appointment as general foreman of the Toledo, St. Louis & Western shops, at Frankfort, Ind., was mentioned in these columns recently, was, on the occasion of his leaving the C., R. I. & P., presented with a gold watch by the shop men at Cedar Rapids, Ia. He held the position of shop foreman on that road. Mr. Moore is a valued contributor to RAILWAY AND LOCOMOTIVE ENGINEERING.

Nicholas C. Gilman, of Columbia, Pa., one of the oldest locomotive engineers in the employ of the Pennsylvania Railroad Company, reached his 70th birthday on August 23, and, having reached the age limit he was, on September 1, placed on the retired list of the company. Mr. Gilman has been in the company's service 51 years and for 36 years was engineman on the Columbia accommodation train from Columbia to Philadelphia. During the 36 years Mr. Gilman has had his present run, and until two years ago, he served with but three conductors, Captain H. A. Hambright, Judge John W. Michael and Charles A. Jeffries, the latter having been his conductor for 26 years.

Mr. Harry M. Pflager has resigned his position with the American Steel Foundries to accept a position with the Commonwealth Steel Company, of which company he was recently elected vice-president. Mr. Pflager was for many years mechanical superintendent of the Pullman Company, at Chicago, and afterwards vice-president of the American Clock Company, at Chicago. He will direct his attention to the sales department and have his headquarters at the Commonwealth Steel Company's offices, in the Bank of Commerce Building, St. Louis, and his many friends will be pleased to know of this new recognition of Mr. Pflager's marked ability, and will wish him every success in his new position.

Obituary.

Edwin Atlee Schoen, aged 38, former vice-president and general manager of the Pressed Steel Car Company, of Pittsburgh, died recently at his country place, Saranac Lake, N. Y., after an illness of about a year. He was a son of Mr. C. T. Schoen, and was for years connected with the Schoen Manufacturing Company.

John R. Slack, who not long ago had been promoted to the position of assistant to the general superintendent from that of superintendent of motive power on the Delaware & Hudson, died recently in New York at the age of 41. He was a graduate of the Stevens Institute of Technology and of Columbia College. His first railroad work was on the New York Central, whose shops he entered as an apprentice, and in 1868 he had risen to

the important position of mechanical engineer of that road. He subsequently became mechanical engineer of the Central Railroad of New Jersey. He left that position to become assistant superintendent of the Delaware & Hudson. In the service of this road he rose by successive stages to the important and responsible position which he held until the last. His many friends sincerely mourn his loss.

F. D. Adams, probably the oldest master car builder in the ranks of retired officers, and one of the pioneers in the formation of the M. C. B. Association, died recently, at his home in Buffalo, at the advanced age of 82 years. He began car work in 1847, when he entered the employ of the Norwich Car Company, of Norwich, Conn. He subsequently entered the service of the Buffalo Car Works, and in 1859 he became M. C. B. of the Buffalo & Erie Railroad. He left railroad work to become superintendent of the Ohio Falls Car Company, but in 1870 he took the position of M. C. B. on the Boston & Albany, and in this company's service he remained 26 years.

high speed steel, from five to seven pairs of 42 in. steel tired wheels are turned in ten hours. This gives an average of about thirty-six pair per week. The chuck jaws in the face plates, which the makers call the "Sure Grip," hold the wheels rigidly in place so that the full power of the machine can be utilized. Self hardening tool steel, $3 \times 1\frac{1}{4}$ ins. can be used; this is large enough to prevent springing and breaking, and the large cross section also has the advantage of carrying away the heat generated at the cutting edge. The cut on the edge should be started next the flange, the work being done with a round nose roughing tool with $\frac{3}{8}$ to $\frac{1}{2}$ feed, and the operation takes from 24 to 45 minutes. The outer edge of the tire is then finished and after that the flange. It has been found that the output of the lathes is greatest when the feed and depth of cut are at a maximum, rather than when a high speed is used. The usual speed is from 6 to 10 ft. per minute. The Niles-Bement-Pond Company will be happy to send a copy of the *Progress Reporter* containing full in-

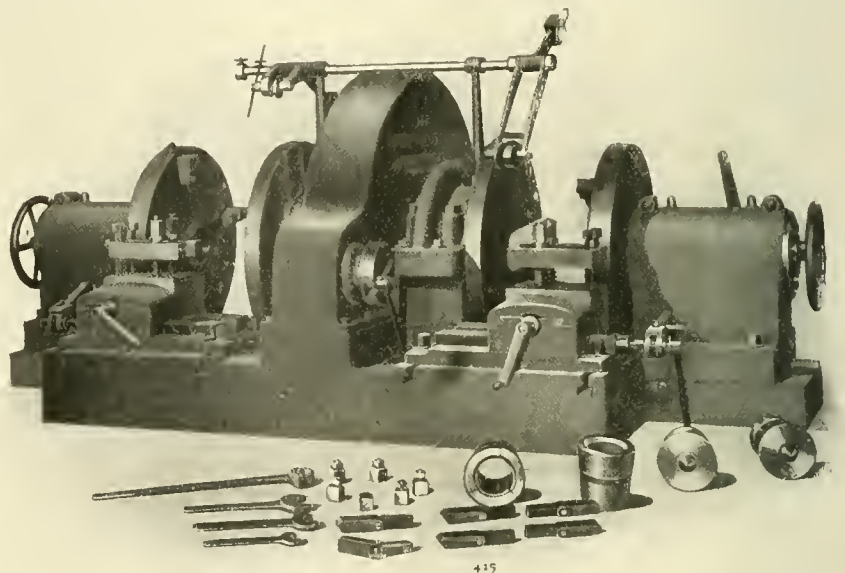

LATEST POND STEEL TIERED CAR WHEEL LATHE.

retiring from active work in 1866. Mr. Adams took a prominent part in the formulation of the first code of car interchange rules in 1876, and he was president of the M. C. B. Association in 1871. His was a long and eventful career and when the call came he may be said to have departed this life full of honors and years.

New Car Wheel Lathe.

In the September issue of *Progress Reporter*, which is published by the Niles-Bement-Pond Company, of New York, the latest Pond steel tired car wheel lathe and equipment is shown as a frontispiece. In this lathe, with a good quality of

formation concerning this new and very efficient tool to anyone who is interested enough to apply to them for it.

Although the Baldwin Locomotive Works, of Philadelphia, are repairing engines for the Erie Railroad, right along, the specific order for 600 engines to be repaired, to which we referred last month as a Baldwin contract, has been awarded to the American Locomotive Company.

Among men who have any sound and sterling qualities, there is nothing so contagious as pure openness of heart.—*Nicholas Nickleby.*

The daily press of the country from time to time breaks forth into a wail of sorrow over the fact that the famous engine, 999, on the New York Central, or the "Queen of the Iron Rail," as she was recently called, has been displaced by the more modern 4-4-2 engines, which now haul heavier passenger trains. Engine 999 has recently had what may be called a "heavy repair," and she will then make her mileage hauling fast, or perishable, freight, as she recently did between Carthage and Utica. She may even haul Uncle Sam's mail again, as she did before that. But though not in the public eye, 999 will get there just the same. Anyone who feels very sorry about 999 ought to remember what the Mogul told Kipling's .007: "Now I"—said the Mogul—"I handle the flying freight—e-leven cars just worth anything you please to mention. On the stroke of eleven I pull out: Costly—Perishable—Fragile—Immediate—that's me! Suburban traffic's only one degree better than switching. Express freight's what pays."

Discovery of Process for Making Hard Rubber.

The general principle may be accepted as true that the man of industry will be the architect of good fortune that enables him to stand before kings, but there have been exceptions where the slothful man meets undeserved reward.

There was once a machinist named George, who worked at the bench and was always more interested in hearing the quitting time whistle blow than in any other event of the day. One day the first yell of the whistle found him with his hammer in the air, and being alarmed lest he should make even part of a stroke beyond working hours, he permitted the hammer to fall and it broke a bottle containing a certain chemical which happened to be on his bench and the chemical ran over a sheet of rubber that also was on the bench. To wipe up the mass after the whistle had blown was not the way George did business, so he went home. In the morning when he examined the rubber that had soaked all night in the chemical he found that it was as hard as a piece of board.

Here now came in the worldly wisdom of this machinist. Instead of cleaning up his wise bench, throwing the spoilt rubber and broken chemical bottle into the rubbish box without thinking anything more about the mishap, George reflected that the change in the consistency of the rubber was due to the chemical that had been anointing it all night. Then the question occurred, Would hard rubber have any value as an industrial product? The secret of how to make hard rubber was carefully guarded, a company was formed to put articles made from it upon the market and the discoverer is now a multi-millionaire.

The Coming of the Cold Drawn Steel Boiler Tube.

All the navies of the world are using cold drawn seamless steel tubes in their boilers, because that material and method of construction produce the most reliable form of tube. A large percentage of our railways are using steel tubes, but they are purchased as charcoal iron and paid



CHARCOAL IRON TUBE.

for as such under the impression that charcoal iron is a material superior to steel for tube making purposes. We do not know of any line of railway supplies where greater deception has been practiced than in the pretense of putting charcoal iron into boiler tubes. A large proportion of that so-called charcoal iron is Bessemer steel and it passes the standard Master Mechanics' Association tests for knobbed hammered charcoal iron quite as well as the real material would pass. The fact



COLD DRAWN SEAMLESS STEEL TUBE.

is that the name "knobbed hammered charcoal iron" is used to deceive and is used very successfully for that purpose since such a material is not on the market at a price which would compete with steel.

In a report submitted to the Railway Master Mechanics' convention in 1901, on Boiler Tubes, the statement was made that charcoal iron tubes pitted less than steel tubes. This was not based on any exact

information or investigation, but was the impression of some of the members. Pitting means corrosion and is generally manifested in the effect that acid has on the material. We have recently seen acid tests made of pieces of knobbed iron tubes and cold drawn open hearth steel tubes, and the annexed illustrations show the effect of the treatment on the two kinds of material. It forms an object lesson worth remembering. The charcoal iron which is reported to be peculiarly immune from corrosion, was largely eaten away, while the steel stood the same treatment with very little damage.

In discussing the relative behaviors of iron and steel tubes, it should be remembered that there are two kinds of steel used in tube making, viz.: Bessemer and open hearth. Bessemer is largely used as a substitute for charcoal iron and it passes for that material and goes through the physical tests quite successfully, but it fails badly under the severe ordeal of hard service. Open hearth steel, on the other hand, is the material which has rendered the very best kind of service in fire boxes. When converted into a cold drawn tube, its durability is beyond everything that has ever been tried for tube making purposes. No steel maker could impose Bessemer steel for fire boxes without certain detection, yet that unreliable material is largely used for tube making under the name of charcoal iron.

There continues to be decided prejudice among railroad men against steel for tubes, but it arises in a large measure from the conservative tendencies of the people who have charge of our railway motive power. When they come to realize that they have been victimized for years into buying inferior steel under the pretense that it was charcoal iron, they are likely to follow the lead of marine practice, which, after the most thorough kind of investigations and tests, has decided that lap welded tubes are too unreliable for use in high pressure steam boilers.

A very effective, inexpensive and convincing test of the relative merit of "charcoal iron" and cold drawn steel tubes is, to put one-half of each in the same boiler. People sincerely anxious to find the truth can offer no valid objections to the making of such a practical test.

Our Educational Chart No. 7.

We have experienced such a persistent and heavy call for our new transparent chart of the Pennsylvania Lines' engine of the 4-4-2 type, that we desire to call the attention of our friends to the fact that this chart is given away free with every new subscription after August 1, 1904, and all renewals after that date. This arrangement will eventually put the chart in the hands of all our subscribers who remain on our books.

Handy Shop Tools.

BY J. A. BAKER.

While large and well equipped railroad plants generously provide their men with up to date tools, the less fortunate brother has to lie awake nights and evolve ideas to successfully compete with them in or-

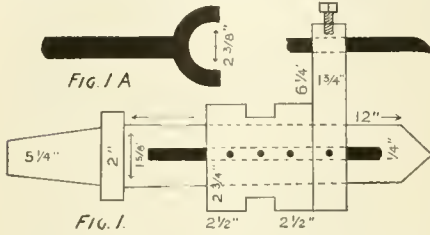

TOOL FOR TURNING TUMBLING SHAFTS.

der to hold down the cost of production. During a recent trip through the Lackawanna shops at Utica and East Buffalo, I saw several tools that for simplicity and efficiency are hard to equal.

Fig. 1 shows a tool used for turning tumbling shaft journals, and Fig. 1a is the guide which secures the movement of the tool and is secured on the tool post of the traveler.

Fig. 2 is a double cutting tool for rocker arm and link hanger ends. Various sizes of sleeves are used on the center post to conform with the different openings.

Fig. 3 shows a tool for cutting cylinder and valve packing rings. It is secured to the tool holder and on boring mills having two independent bars six rings can be cut with one operation.

Fig. 4 is a pinch bar, simple but very effective, and shows its mode of operation.

Fig. 5 illustrates a bar used in shifting the crosshead and piston. The point of the bar rests against the guide block and the notched arm engages the crosshead.

Figs. 6 and 6a shows a front and side view of another type of turning tool for

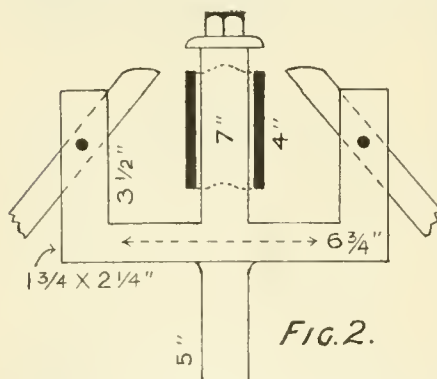

DOUBLE CUTTER FOR ROCKER ARMS.

lifting shaft journals and with greater range of work to be done. It obviates the necessity of having the blacksmith bend the arms. The shaft is placed in an ordinary lathe with the lifting arm resting against the body of the lathe. The lathe is set in motion and the guide secured to the tool post as the traveler engages with

the tool. The cost of turning a lifting arm, which formerly averaged \$1.50, has been reduced to 18 cents, since this tool has been put into use.

Improvements on the Locomotive.

In our last issue we published a digest of the portion of the address of Professor Goss on "The Passing of the American Locomotive." The next part of his paper related to

LOCOMOTIVE VALVE GEAR.

Discussing this part Professor Goss said that in connection with the machinery of the engine, great improvements have been effected by the substitution of steel where cast iron was formerly employed. The working parts have been made much more durable by increasing the area of the bearing surfaces. Piston valves with their superior balance have largely superceded flat valves. By

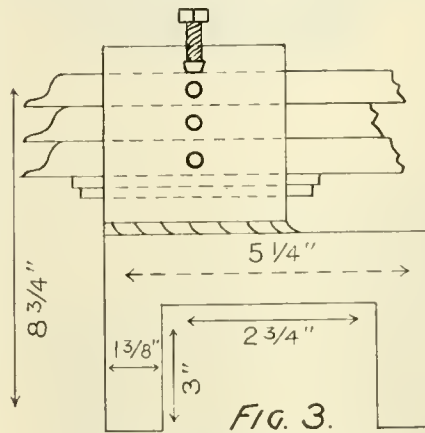

CUTTER FOR CYLINDER AND VALVE PACKING RINGS.

use of driving wheels of larger diameter and reciprocating parts of superior design, the problem of counter balancing driving wheels has been simplified.

In regard to valve motion the shifting link motion has been generally used in this country because it is a good device. Discussing the English practice with valve motion, Professor Goss said that the Joy gear was generally employed there owing to the restrictions of room for eccentrics with inside connected engines. This is, we think, a mistake, for the Joy motion is by no means general on British locomotives and its use is on the wane.

After briefly referring to the continental practice with valve gear, the author continued, saying that the choice of a gear is in most cases doubtless made from practical considerations rather than from theoretical. In working out the general lines of the design of a locomotive, one or another form adapts itself to the purpose better than others. Of course, this is not true in all cases, but assuming the choice of gear to be controlled by proper limits, it might be so, for it is not a difficult thing to secure a distribution of steam

within a locomotive cylinder which will give results approaching maximum performance.

A chief requisite in any valve gear is a degree of stiffness, and an absence of lost

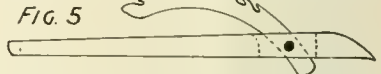
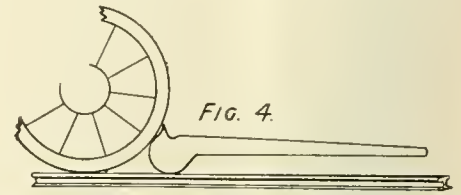

PINCH BAR AND CROSSHEAD MOVING BAR.

motion which will make the movement of the valve positive. These qualities are especially necessary in the gear of a locomotive, for in this type of engine, the port opening at running cut-off is frequently not over a quarter or three-eighths of an inch, so that even a slight defect in any of the mechanism between eccentrics and valve produces large proportional effects upon the time and extent of the port opening. Ten years ago, light and poorly designed gear were common defects in the American locomotive. Then it sometimes happened that the steam distribution depended quite as much upon the oil can as upon the position of the reverse lever, and reports are current of an engine which would run well under a partially open throttle but would stop if the throttle were fully opened, the mechanism being insufficient to move the valve when the pressure was heavy upon it. But the valve gear of the modern locomotive is not of this sort. With its heavy and direct connection, its double

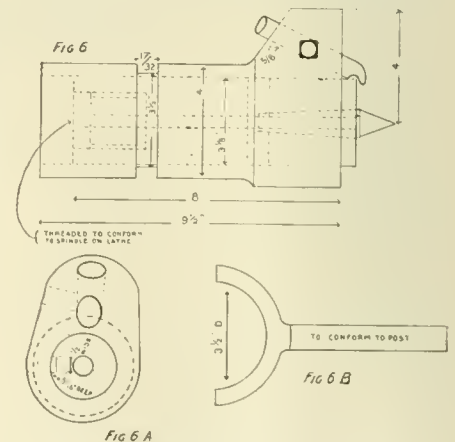

TURNING TOOL FOR LIFTING SHAFT JOURNALS.

suspended link, and with the light weight of the valve to be moved, a marvelously good steam distribution is secured even at the highest speeds. Those who, seeing but one side of a really complicated prob-

lem believe that locomotive valve gears ought to be revolutionized, should investigate carefully before they proceed. They should remember that the modern locomotive under ordinary conditions of running, rarely requires more than thirty-two pounds of steam per indicated horse power, while under favorable conditions, it requires less than twenty-five pounds. Few simple stationary engines exhausting into the atmosphere, with their more complex forms of valve gears, are doing better than this, which is evidence of the narrowness of the margin limiting possible improvements in this direction.

A Little Fellow for the P. E. I.

The Prince Edward Island Railway have recently received some small 4-4-0 engines from the Canadian Locomotive Company, Ltd., of Kingston, Ontario. The road is 3 ft. 6 ins. gauge and the engine we illustrate is, necessarily, not one of our modern monsters. The road is 200

The Allis-Chalmers Company, of Chicago, Lent Testing Machinery to Uncle Sam.

Up in the mining gulch at the World's Fair in St. Louis there are two notable exhibits.

These are the coal testing plant of the United States Geological Survey and the timber preserving plant of the Bureau of Forestry. Each plant depends for its operation or value largely upon the Allis-Chalmers Company's machinery, in each case loaned without pay by the Chicago concern.

The work of the coal testing plant is the determination of the respective fuel values of every grade of coal which may be submitted. A 250 h.p. horizontal Allis-Chalmers engine in this plant not only supplies power for the various mechanical operations to which the samples of coal are subjected, but it also serves to give practical tests through its power-producing qualities, of the actual

from the retort proper, by pumps. While the pores of the wood are all open and practically free from vapor, moisture or air, the preservative mixture is let into the retort from the tanks. The preservatives are thus, under the influence of the vacuum in the pores of the wood, carried into every part of the ties or timbers, no matter how thick or long they may be.

At the plant now established in the Gulch it is intended to treat various lots of ties by various processes. Each batch of ties will then be put into regular service in some railroad track and a record kept of each tie until it is worn out or rotted out. As these tests and records will be official, they will of necessity carry weight.

Extracting a Broken Stud.

BY JAMES KENNEDY.

One of the best features of RAILWAY AND LOCOMOTIVE ENGINEERING is the valu-



4-4-0 FOR THE PRINCE EDWARD ISLAND RAILWAY.

W. S. Poole, Mechanical Superintendent.

Canadian Locomotive Co., Ltd., Builders.

miles long and is credited by the *Pocket List* with having 25 locomotives.

The total weight of this machine is 70,000 lbs., of which 44,800 rest on the drivers. The cylinders are 15x20 ins. and the driving wheels 54 ins. in diameter. The boiler is a radial stay, extended wagon top type. The heating surface is 836 sq. ft. in all. The flues give 746 sq. ft. and the fire box 90 sq. ft. There are 170 tubes in the boiler, 9 ft. 6 ins. long. The total wheel base of engine and tender amounts to 39 ft. $\frac{1}{4}$ in.

The tender when loaded weighs about 55,300 lbs. The tank holds 2,200 Imperial gallons and $2\frac{1}{2}$ tons of coal. The tender frame is made of channel iron. A few of the principal dimensions follow:

Wheel base of engine, rigid, 7 ft. 9 ins.; total, 19 ft. 8 ins.
Length over all, engine and tender, about 48 ft.; width, 9 ft. $4\frac{1}{2}$ ins.; height, 10 ft. $10\frac{1}{4}$ ins.
Size of fire box, $33 \times 66\frac{1}{4}$ ins.

values of the various coals. Samples of coal are analyzed, burnt under boilers with varied conditions, coked and used for gas producing. Their values for gas production and the power qualities of the gases are tested in a gas engine.

The timber preserving plant which stands about a hundred yards further up the Gulch than the coal testing plant is under the direction of Dr. H. Van Schrenk, of the Shaw Gardens, St. Louis. Its special work is to test all the various methods offered for preserving railroad ties. For this purpose the Allis-Chalmers Company has lent, free of charge, a tie-treating retort and two tanks for the preservative solutions used.

The system supplied by the Allis-Chalmers retorts and tanks consists in placing the ties in the retort where the first operation is to dry out all of the water and sap by heat and exhaust all of this and the greater part of the air

able information to be obtained in the detail work of every day construction and repair in railroad machinery, and along that line there are countless variations of methods in use, a comparison of which cannot fail to elicit information tending to the adoption of the best methods to be used in securing the desired end in constructive and repairing work.

In the apparently simple matter of extracting the end of a broken stud it might seem that a uniform plan at once easy and effective would be in universal use among railroad men, but such is not the case. Machinists generally are possessed of an ill-defined notion that in the event of the stud being broken close to the metal into which it has been screwed, the only method is to drill a hole about three-sixteenths of an inch lesser in diameter than the stud directly through the center of the stud, as in Fig. 1, and then tap out the hole in the usual way with two

or three graduated tapering taps. The result is seldom satisfactory. The compressed and consequently hardened portion of the stud remaining around the new hole breaks into pieces and together with the tap they tear away portions of the thread in the body of the metal, the result invariably being that taps of a larger size have to be used before a thread sufficiently reliable can be reproduced in the stud hole, necessitating as a consequence a new stud with an enlarged end. So generally is this the case that a number of steam chest and cylinder head studs are

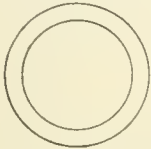

FIG. 1.

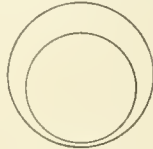

FIG. 2.

usually kept in the store room in anticipation of such conditions.

Fig. 2 is a simple illustration of the beginning of a more successful method of extracting the broken end of a stud with greater chances of little or no damage to the old thread.

As will be observed, the new hole, which may be about three-sixteenths of an inch lesser in diameter than the stud, should be drilled as nearly as possible to the edge of the broken stud, care being taken not to penetrate the body of the metal and so destroy a portion of the thread. It is a matter of indifference as to the drill running exactly straight, so that the thread at the thin edge is not touched.

In the crescent shaped portion of the broken stud remaining, a groove should be cut in the thickest part with a round nosed chisel, as illustrated in Fig. 3, care being taken as in the drilling of the hole,

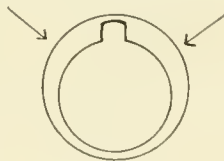

FIG. 3.

not to penetrate the thread in the body of the metal.

When this is done a sharp blow with a hammer on the round nosed chisel pointing towards the center of the hole at the arrow points indicated in Fig. 3, invariably breaks the crescent shaped remainder of the broken stud into two pieces, leaving the thread intact. The metal at the points struck, by reason of its sufficient thickness has the cohesion necessary to remain together and so leave the thread uninjured, such portions of the thinner shell of the stud as may remain at the points where the fractures occur being easily removed.

It may be imagined that by drilling the hole in the center of the stud and cutting two notches in the shell with a chisel the pieces could be as readily removed, but experience will show that an equal portion of metal forming the shell of the broken stud is possessed of much greater toughness than an eccentric or elliptical shell which breaks readily at the thinnest points, facilitating the removal of the broken stud in larger pieces and thereby saving the original thread in the body of the metal which is the real advantage gained by the method described.

A Handy Shop Turntable.

In the B. F. Sturtevant Company's shops, at Boston, one may see a very handy form of shop turntable for turning lorries, material carrying trucks, etc. The illustration shows a turntable tilted up so as to show the mechanism. The bottom frame is a casting and is fitted with four roller wheels which turn on composition axles. The wheels are made hollow and may be partly filled with oil so as to lubricate the bearings. The table itself is recessed out on the upper side

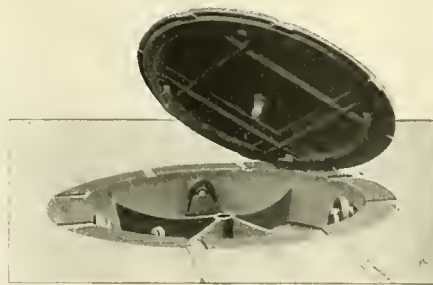

CONVENIENT SHOP TURNTABLE.

for two tracks which cross it at right angles, and underneath it is substantially ribbed and altogether is made very heavy to prevent warping or breakage and it is thus able to stand lots of hard but fair usage.

On the under side, the circular path, which moves over the four rollers when the table is turned, is chilled so as to reduce wear to a minimum while it gives a hard, smooth surface. In this chilled pathway for the wheels are four curved notches or depressions. These are so spaced that when the table is in position the small roller which can be seen in the engraving as standing by the near margin of the frame close to the left hand rail, engages with one of the depressions, thus making an effective lock which holds the tracks in register. The small roller or lock wheel is held up by a spring which acts automatically and stops the table at each quarter. Exact centering is secured by a chilled conical bearing at the center, upon which the table turns. The bottom frame is let into the floor so that the top flange is flush. The whole is sub-

Oil vs Grease

Is grease better than oil?
Is oil better than grease?

Where is it better to use
oil and where grease?

These are the questions upon which "doctors disagree" and engineers differ, and it is indeed a difficult matter to lay down any hard and fixed rules.

The Traveling Engineers have this Oil vs. Grease subject up for discussion at their Fall convention and the reports will be interesting and instructive.

Exhaustive experiment and years of practical experience have proved that the addition of Pure Flake Graphite to oils or greases enormously increases both their efficiency and endurance, enabling a given oil or grease to do heavier duty than would otherwise be possible. Or to express the same thought another way: if Dixon's Pure Flake Graphite be used, a thinner, less viscous oil or grease may be employed with entire safety and satisfactory results. Dixon's Flake Graphite imparts to friction surfaces a wonderful smoothness that relieves oil or grease of a very considerable portion of its task of keeping the (microscopically) rough surfaces apart.

"Oil vs. Grease"

is the title of an interesting new booklet of the Dixon Company, a copy of which will be promptly sent to every railroad man who requests it.

In writing please mention this journal.

**JOSEPH DIXON
CRUCIBLE CO.
Jersey City, N. J.**



“Throw Away your Glue Pot”

Why have the smell of boiling Glue around you all day, and the waste and expense of boiling dry Glue, when you can for less money use

ARMY & NAVY LIQUID GLUE

Not a Fish Glue

but a pure hide and sinew glue in liquid form.

The Glue of the 20th Century

will do twenty-five per cent. more work than a fish glue.

No smell. No dirt. Always ready for use.

Let us send you Samples and Prices

WACHTER MFG. CO.
BALTIMORE, MARYLAND

stantially made and well braced. The table is a good example of a well designed and serviceable piece of shop furniture.

Armstrong Brothers' Exhibit.

The Armstrong Brothers, of Chicago, otherwise known as “The Tool Holder People,” have an extensive exhibit of their wares at the Louisiana Purchase Exposition. The exhibit comprises a complete line of tool holders using inserted cutters for all operations on the lathe, planer, shaper and slotting machine, universal ratchets, planer jacks, clamp dogs and drill holders, also a com-

roads have been compelled to use pine, which does not last as long as oak. It is estimated that about 60,000 acres of woodland are cut down each year to supply railroads with ties. About 110,000,000 new ties are annually put in the tracks of existing roads, to say nothing about new roads which have to be entirely equipped. The cost of the ties is increasing all the time from the gradual reduction of the sources of supply, and the price is still further raised by transportation charges, for those roads which do not have forests or woodlands along their line. All this seems to point in the direction of the steel tie as the coming

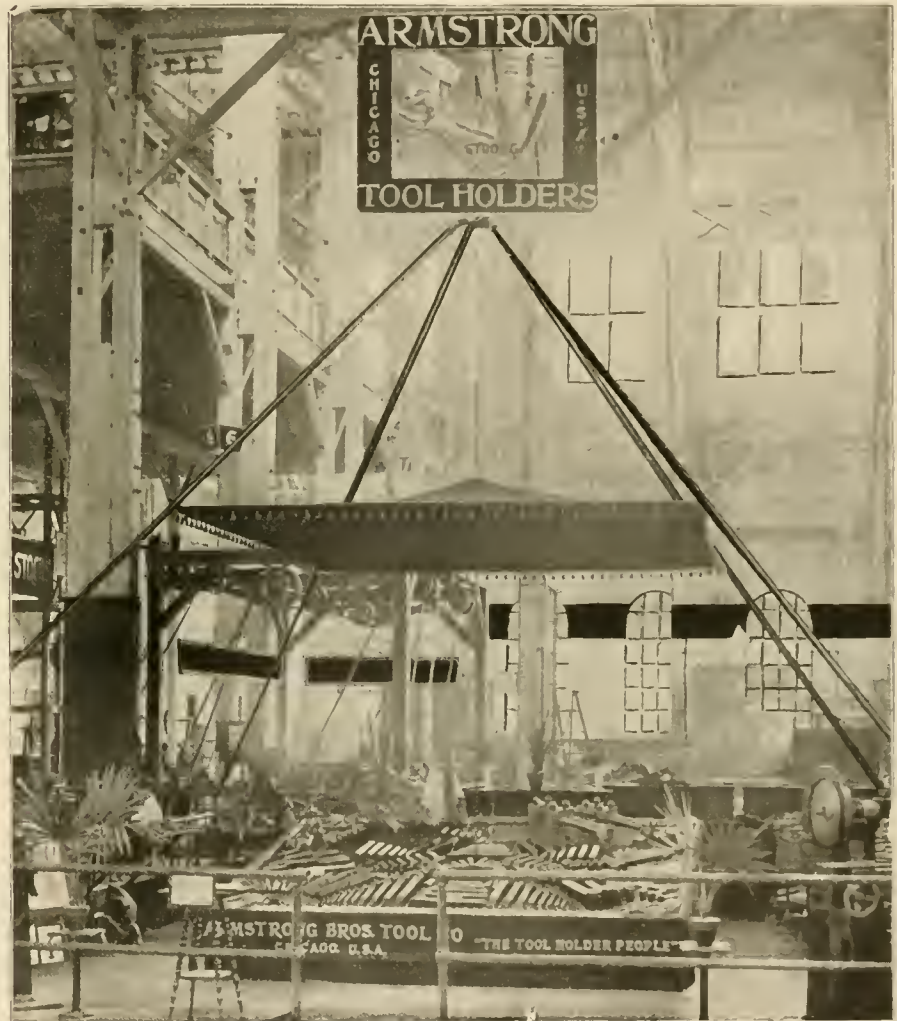

ARMSTRONG BROTHERS' EXHIBIT AT ST. LOUIS

plete line of lathe tool cabinets. The Armstrong cutting-off and grinding machine especially designed for cutting off and grinding self hardening steel cutters for use in Armstrong tool holders. This is exhibited for the first time, and is believed by many visitors to be one of the most novel metal working machines in the Palace of Machinery.

Oak for railroad ties is at a premium and northern roads are experiencing some difficulty in getting hard wood ties. Many

material for permanent way, but there is yet a chance that some absolutely perfect wood preservative may be discovered which would solve the problem and by reducing the constant drain on our forests and woodlands, permit the wood growing industry to recuperate.

“Everybody’s thoughts are their own, clearly.”

“They wouldn’t be if some people had their way.”—Nicholas Nickleby.

Repair to Cracked Cylinder Saddle.

A very neat cylinder repair job may be seen on one of the engines of the Central Railroad of New Jersey, which was done in the company's shop at Fidler's, which is presided over by Mr. Hugh Montgomery as general foreman.

A crack was discovered in the saddle casting close to the frame seats, and this crack was the full depth of the casting and ran back far enough to seriously en-

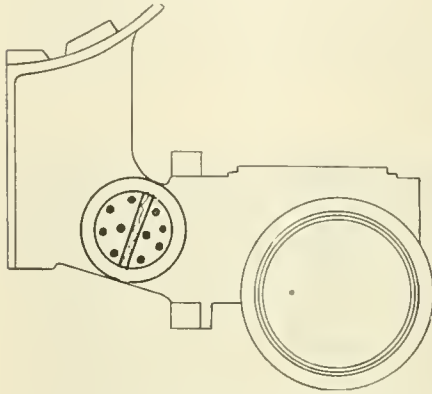

ROUND HOUSE REPAIR JOB.

danger the steam passages, though the latter was intact when the repairs were made.

To securely close up and hold this crack tight, a 7 in. disk of iron was turned up in the lathe, the disk being 1½ ins. thick. Ten holes were drilled in it, as shown in our illustration, and the disk was cut in two in a shaper. The two semicircular halves of the disk were then bolted up with 7/8 in. tap bolts, one on each side of the crack and about 1/4 in. space was purposely left between the pieces. A 1½ in. square iron band was then shrunk on the boss, and as the circular band cooled the crack entirely disappeared, and the engine has been doing good work ever since, with no signs of the crack making any attempt to open up.

"Langwidge."

A minister was expostulating with a railroad official regarding the bad language used by a young man owing to having missed his train through the misdirection of a porter. He put the case in this way: He used fifty-six "unparliamentary" expressions, as follows:

Seventeen adjectives of a lurid hue. Five appeals to the Almighty.

Two invocations that his own eyesight might be destroyed.

Three invocations upon the eyes of the referred official.

Seven iterations of the name of the infernal regions.

One side issue, necessitating the name of the Messiah.

Seventeen adjectives of simple obscenity.

Four expletives of an unclassified nature.—*Philadelphia Press.*

Science is digested knowledge. It began with reflective life, and is not confined to mankind. A deer grazing in the forest encounters a scent which inherited knowledge tells it is left only by a wolf. Science tells the grass eating animal to run away from the vicinity of the flesh eating wolf. Man has made greater use of science because his inventive and reflective powers are superior to those of animals.

The B. F. Sturtevant Co. is fitting up quarters in its big plant to be used for an emergency hospital, in case of accident to employees. It is to be equipped with all the appliances known to medical and surgical science for the proper care of the men who may get injured in the discharge of their duties until they can be removed to their homes. A graduate nurse and medical student will be in charge and a local doctor will attend to all surgical cases.

Baby Engine for the Japs.

Probably the smallest locomotive intended for real work ever built in this country was recently turned out of the Baldwin Locomotive Works at Philadelphia. The engine weighs in all about 2,500 pounds, and is destined for Japan. Judging from the work it is intended to do, horse power does not enter into the question. The little machine can be better described as a four-man power engine. It will be used for hauling tea, rice, etc., and it runs on a narrow gauge road. Many such "railways" exist in Japan and two coolies are employed to push each car. This little engine is intended to replace the coolies and if satisfactory more will be ordered.

Smoke Stack Crane.

At the shops of the Pennsylvania Lines West in Pittsburgh a handy smokestack crane is used, made of 1½ in. round

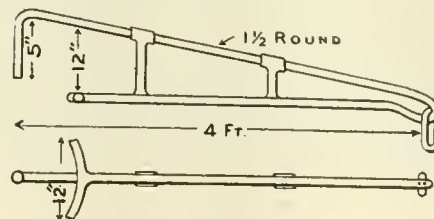

SMOKE STACK CRANE.

iron, bent at an angle with a link carried at the point. The horizontal lower member has a foot at the back end curved to suit the contour of the stack, and two struts which resemble hand rail brackets are slipped over the upper bar and welded to the lower one. The upper bar has a hook which drops down inside the stack, and, so to speak, takes a grip. The crane is light and can easily be swung round to any required position.

H. S. PETERS'
BROTHERHOOD TRADE MARK **OVERALLS** REGISTERED

have gone to almost every part of the World where Overalls are worn and are everywhere conceded to be the **BEST**. Every point of material, cut, construction and finish is carefully looked after; the only way that superiority can be attained. Every garment is absolutely guaranteed. The Patented, Fleece-lined, Safety Watch Pocket is alone worth a whole suit of any other make.

I'll send sample suits, charges paid, to any place in the World where mail or express goes, where I have no retail agency; sample materials and full particulars for the asking.

UNION MADE
OF COURSE —
B.L.E. 3—H.S. PETERS—B.L.E. 171
DOVER, NEW JERSEY, U. S. A.

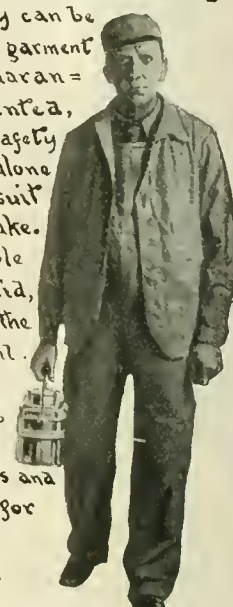

The Twentieth Century Master Mechanic

Won't use solid Mandrels. Cost too much, take up too much room and don't give satisfaction.

Nicholson Expanding Mandrels

Take everything from 1 to 7 inch holes. Take up little room—always ready and you can buy four sets for the cost of one of the solid kind.

Are You Using Them?

Catalogue tells you more about them.

W. H. Nicholson & Co.
Wilkesbarre, Pa.

**Keep
Your
Mind
On
It**



**CRANDALL'S HELIOS
AIR PUMP and
THROTTLE VALVE**

PACKING

**Put Up in Sets
Exact Fit to Rod and Box
Send Trial Order**

**The Crandall Pkg. Co.
123 Liberty Street
N. Y. CITY
Chicago Office, 30 La Salle St.**

WANTED

Automobile, October, 1900.
Back numbers—Motor Vehicle Review,
1902; Motor Age, 1900 and 1901.

Write to **MRS. C. F. MacDERMOT,**
Hotel Touraine, Boston, Mass.

Twentieth Century Locomotives

By Angus Sinclair Company. It has 670 pages dealing with the designing, constructing, repairing and operating of modern locomotives. Work shop operations, care and management of engines. Quick repairs on the road, shop tools, shop receipts, train resistance and power calculations, definitions and tables. Standard types of engines illustrated and described. Fully indexed. Most all round useful modern compendium of the locomotive.

:: :: **PRICE \$3.00** :: ::

THIS OFFICE

Russia's Only Building at the Fair

Russia's only building at the Louisiana Purchase Exposition, the center of much interest in the Palace of Transportation, excites only regret that the withdrawal of the Czar's government from formal participation in the Fair has deprived it of larger and more comprehensive displays of the same attractive type. The pavilion in the Palace of Transportation, which was erected by the Westinghouse Company, Limited, of St. Petersburg, as a feature of the Westinghouse brake exhibits, is representative in every feature of Russian art and workmanship, and is recognized as the general Russian rendezvous at St. Louis. In the Palace of Machinery, the same company, which has made every effort to ensure a characteristic Russian exhibit at the Fair, has furnished a small Russian kiosk at the head of the row of national booths erected by the different

notched together so closely that no open joints remain to be plastered, as in American huts. The rafters of the high roof, also, are mortised into the plate, and no nails whatever are necessary in the construction—the entire building having been shipped to this country in boxes. The fantastic taste of the peasants is indicated in the curiously sawn eaves, gables and cornices, which are elaborately ornamented and painted in the gayest colors. The material used throughout is a white pine from the forests around Moscow. Railroad men visiting the Fair should not fail to visit this unique exhibit.

"Before and After" is the title of a little publication got out by the Ingersoll-Sergeant Drill Co., of New York. It contains two half-tones of the North Amherst quarry of the Cleveland Stone Company,

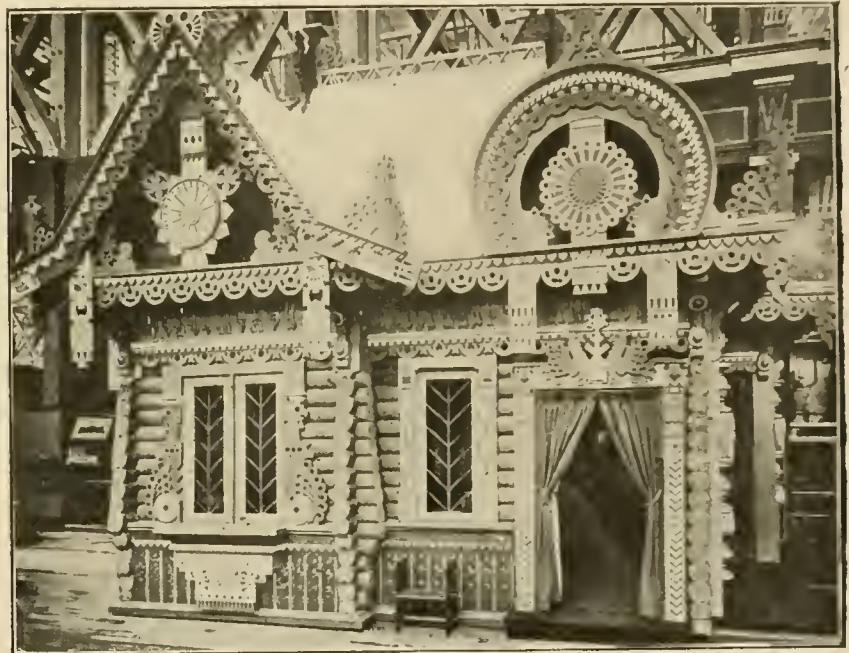

**PAVILION OF THE WESTINGHOUSE COMPANY, LTD., OF ST. PETERSBURG.
AT THE ST. LOUIS EXPOSITION.**

Westinghouse companies of Enrope and America, and at both places, as a manifestation of Russian hospitality, Russian tea, brewed in curious old samovars, and suchari, a sweet native biscuit, are served to visitors of the company by Russian girls wearing richly embroidered boyarin costumes.

The pavilion in the Palace of Transportation covers a space 20 by 25 ft., and is 25 ft. high. It was constructed by peasant builders, near Moscow, after designs by the native architect, Baranowsky, who has done much important work in St. Petersburg. Although buildings of a similar character are still built to-day in the interior of Russia, on a less elaborate plan, for small homes and pavilions, the style of construction is quite primitive, the exterior being that of a forest log cabin. The logs are neatly hewn, however, and

one picture taken before the installation by the Ingersoll-Sergeant Drill Company, and shows the whole quarry filled with steam and smoke so that the outlines of the ledges of rock in the quarry are quite indistinct though the figures given below where the cost of operation is shown stand out very clearly and are not surrounded by any fog. It cost \$337.75 per day to operate all the machinery. After the installation the figures for daily operation were \$172.80 and the photograph, taken after a Central Compressed air plant was in operation shows a clear and distinct picture without fog or vapor or smoke. The quarry must now be very comfortable for the men who work in it and a glance at the new operating figures is no doubt very comfortable for the company which installed the air plant. Write to the Co. for particulars.

Traveling Engineers' Convention.

FIRST DAY.

The twelfth annual convention of the Traveling Engineers' Association opened in the assembly hall of the Lexington Hotel, Chicago, Ill., Tuesday morning, September 13, J. D. Benjamin, second vice-president, Chicago & Northwestern Railway, occupied the chair. In his opening address he touched on the important problems of fuel saving, lubrication, etc. He said that the use of grease in driving box cellars would ultimately supersede other kinds of lubrication. He touched on the necessity for careful selection of firemen with a view of procuring the best material for both firemen and engineers. He also referred in a brief way to the coming of electric traction in steam railroading, and cited the specific case of the New York Central organizing an electric line across New York State, and obtaining power for its operation from the Niagara Falls plant.

The secretary's report showed the association to be in a prosperous and healthy financial condition, there being a total membership at this time of 446 members, a gain of nearly 100 members during the past year.

After a short recess for payment of dues and for the ladies to retire, the first paper on the "Selection of Firemen," by Mr. E. R. Webb, was read by the author. Mr. Webb's paper stated that railroad conditions had widely changed in the past few years, heavier and more powerful locomotives being now used than formerly, necessitating stronger and huskier firemen than in the earlier days. He preferred the ordinary, robust farmer's boy in preference to the high school and college graduate, as a fireman candidate. He referred to the old hardy stock of "boys who went barefooted from snow to snow" as making the best firemen. In the discussion which followed it seemed to be the consensus of opinion that the modern boy preferred easier work than firing a locomotive and that the better educated boys would not stick to the work, preferring office work or some easier employment, thus necessitating recruiting from the ranks such boys as were better adapted for muscular work than for office work. It also developed in the discussion that good material was found in the ranks of bridge and work gangs by the traveling engineer in his trips over the road. Also good material was found in shops around the ash tracks, coal tracks and laborers among the shops. It further developed that kind treatment retained a fireman in the service, as did regular engines, as much as anything else.

Encouragement and interest on the part of the traveling engineer and master mechanics oftentimes produced better firemen. One member believed that the

assignment of regular engines to regular men and keeping the tonnage within economic limits would do much to keep the fireman interested and satisfied, and thereby make him a more valuable man.

Mr. G. W. Wildin took exception to the premium placed on the non-educated man for this work, as he believed that brains and intelligence should have a value even in this field. He resented the implication that the modern fireman should be "Strong in the back and weak in the head and deficient in education." He further believed that the automatic stoker was the only settlement of the question.

Another member believed that the cutting of the long divisions in two, making a run not less than 100 miles and not greater than 150 miles, would do much toward procuring and keeping better firemen, as well as having better power.

The next paper discussed was the "Progressive Questions and Answers for Examination." As this paper was lengthy it was read in abstract by C. B. Conger. In the discussion that followed it appeared to be the consensus of opinion that the questions were properly and skilfully devised, and certain members believed that answers should be added to give additional value to the book and supply firemen with needed information. This was objected to on the part of other members who believed that firemen would memorize the answers and thereby defeat the object of the questions and answers. After a lengthy discussion of this point a vote was taken and resulted in defeating the motion for answers to be supplied to the questions.

(Subsequent proceedings will appear in later issues.)

The American Locomotive Company have issued a very attractive catalogue in which their exhibit at the Louisiana Purchase Exposition is fully described and illustrated. The twelve engines which form the bulk of the exhibit are given in excellent half-tones and line engravings with descriptive specifications, and the maximum tractive effort is included. Not only are the engines shown in the catalogue but there are two views of a cylinder and half saddle with cylinder covers off and enough broken away to show the piston valve, and the by-pass valves and an interesting description of these pieces of mechanism is given. After that comes a line engraving showing what direct valve motion is and describing the same. Then follows a boiler with a wide fire box, radially stayed, illustrated and described. Some views and a short description of trailing trucks conclude the miscellaneous reading matter. Then follows the four-cylinder balanced compound, for the N. Y. C., the articulated freight engine for the

Besides ASHTON LOCOMOTIVE STEAM GAGES



WE MAKE

Duplex Air Gages
Gage Testers
Blow-off Valves
Chime Steam Whistles
Pop Valves

ALL OF A SUPERIOR QUALITY

Catalogue on Application

The Ashton Valve Company, 271 Franklin Street, Boston, Mass.

American Locomotive Sander Company

13th & Willow Sts., Philadelphia, Pa.

Proprietors and Manufacturers,

LEACH, SHERRURNE, DEAN,
HOUSTON, "SEE" and CURTIS

SANDERS

JUST PUBLISHED
—THE—

LOCOMOTIVE UP TO DATE

The greatest accumulation of new and practical matter ever published treating upon the construction and management of modern locomotives, both

SIMPLE and COMPOUND

By CHAS. McSHANE

Author of "One Thousand Pointers for Machinists and Engineers." Special Exhaustive Articles were prepared for this new book by the

Baldwin Locomotive Works

Rogers Locomotive Company

Schenectady Locomotive Works

Pittsburg Loco. and Car Works

Brooks Locomotive Works

Dickson Locomotive Works

Cooke Loco. and Machine Co.

Richmond Loco. and Machine Co.

With contributions from more than one hundred prominent railway officials and inventors of special railway appliances.

736 Pages, 6x9 Inches 380 Illustrations

An Absolute Authority on All Subjects relating to the Locomotive

Bound in Fine Cloth, \$2.50

ONE THOUSAND POINTERS

—FOR—

MACHINISTS and ENGINEERS

By CHAS. McSHANE

(Practical Machinist)

Assisted by CLINTON B. CONGER, Air Brake Expert; J. P. HINE, Mem. Div. 37, B. of L. E.; J. G. A. MEYER, Mechanical Engineer; W. M. F. GOSS, Mechanical Engineer; JNO. C. WHITE, Indicator Expert. The only complete work on the locomotive combining both theory and practice. 342 pages, 187 illustrations.

BOUND IN FINE CLOTH, \$1.50

The only book ever indorsed by the International Association of Machinists. Agents wanted everywhere; write for terms, commissions and club rates. Will be sent prepaid to any address upon receipt of price.

GRIFFIN & WINTERS, Pub.

171 La Salle St., CHICAGO, ILL., U. S. A.

Vest Pocket Combination Tool



Wire Cutter, Screw Driver, Glass Cutter, Packing Hook and Burner Grip. Weight 4½ oz. Drop Forged Steel. Always useful Ever Ready.

In Leather Case. Price, \$1.50

WILLIAMS, FROST & CO.
WINONA, MINN.

THIS



BOOK

on pumping, air-compressing and condensing machinery is

Given Away

by each of the following companies:

- Henry R. Worthington
- Laidlaw-Dunn-Gordon-Co.
- Blake-Knowles Steam Pump Works
- Deane Steam Pump Works
- Clayton Air Compressor Works

114-118 Liberty Street, New York

Flexible Spout

Vertically in straight line. Also laterally. The latest Improvement to

Poage Water Columns

American Valve and Meter Company
CINCINNATI, OHIO.

SEND FOR CATALOGUE

B. & O. A Big Four high-speed passenger engine of the Atlantic type, one of the same class for the Vandalia and another for the B. & O., a 2-6-2 for the L. S. & M. S., a 4-6-2 for the Missouri Pacific, an N. Y. C. "consolidation," also one for the Erie, another for the C. & O., a switcher for the Manufacturers Railway, a mogul for Japan, and a four wheel saddle tank engine complete the list. The American Locomotive Company, 25 Broad street, New York, will be happy to send a copy of their interesting catalogue to any one who will write to them for it. It is well worth getting hold of.

A Screw Thread Rolling Machine.

A very ingeniously made machine for rolling the screw threads on bolts is on the market. The operation which makes the thread, consists essentially of moving one thick, flat plate past another similar stationary plate, but without either of them coming in contact. Both these plates or dies are made of ground tool steel and have a series of grooves cut in them the exact shape of the screw thread which it is desired to cut. These dies are placed horizontally while the grooves which are quite straight are inclined and fall slightly, but regularly, from one end to the other.

The screw thread on a bolt always de-

the start and so force it to go in. When it is desired to roll a thread on, for example, a 1 in. bolt, the dies are set the proper distance apart and the operator takes the threadless bolt and places it the proper depth, determined by a stop in the machine and waits for the moving die to draw back to the end of its return stroke. When the moving die begins its working stroke the bolt is caught between the dies and is rolled between them, the operator keeping his hand loosely on the revolving head. Just before the end of the stroke the bolt is rolled out and the operator removing it at once prevents the possibility of the return stroke drawing the bolt back into the machine.

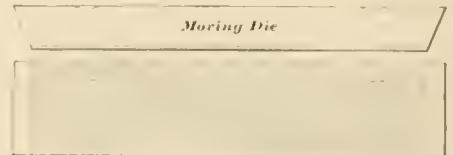

Railway & Locomotive Engineering
MOVING DIE WITH GROOVES FOR ROLLING THREADS ON BOLTS

The thread is, in this way, not cut on the bolt in the sense that it is cut by a tool in a lathe or by the dies of a bolt threading machine. The thread is formed by the upsetting of the metal and as no stock is cut away the burr, so often left by a cutting tool, is not formed. There is, however, a certain

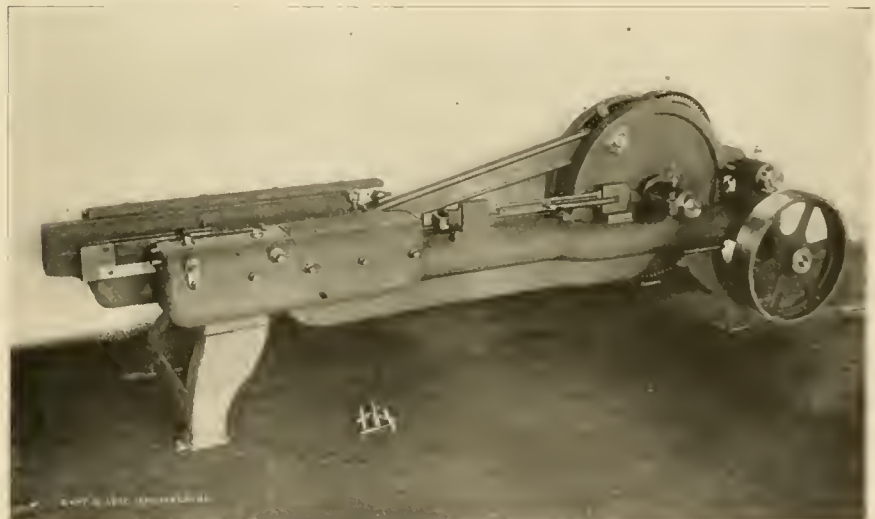

SCREW THREAD ROLLING MACHINE

scends or ascends exactly half the pitch in the distance of half the circumference; therefore, the lowest point of a groove on one die is placed exactly opposite the highest point between grooves on the other die, and the dies are spaced apart just the diameter of the bolt, measured across the base of the threads.

The stationary die is cut away the depth of the threads at the entering end for about one inch, so that the machine may get a grip on the bolt at

amount of scale from rough stock, and fuzz from the finished stock which drops between the dies, and as this would in time injure the lower slide, a slot is made in the bed plate, with a stripper attached to the slide, so that at each revolution the scale or fuzz drops into the slot and is thrown out by the scraper, thus insuring a clean working surface for the lower surface of the slide, which is not cut or scored in any way.

The largest size of thread rolling machine shown in our illustration is adapt-

ed to the rolling of threads on railway track bolts and on all the heavier kinds of bolts and screws. The dies can be made equally well for rolling the U. S. standard, the Whitworth standard, Harvey grip, straight "V" and any other threads which may be desired.

The machines are made by Messrs. Blake and Johnson, of Waterbury, Conn., and are designed for all classes of machine screws up to 1½ in. diameter by 3½ ins. long.

Graphite is a monthly publication got out by the well-known Joseph Dixon Crucible Company, of Jersey City, for the purpose of giving special information concerning the various products manufactured by them. The September issue is of special interest, and contains instructive and seasonable articles on the preservation of metal surfaces with Dixon's silica-graphite paint. The users of paint and those whose business it is to specify or buy paint will be interested in the excellent half-tones of notable steel structures, and the information on good paint and good painting which are given. Among the views given of buildings in course of construction is the Wabash terminal in Pittsburgh, the Fifth Regiment Armory in Baltimore, and Trinity Building, New York, which is a fine modern office building, which shows its connection with the neighboring church by the later style of gothic details which adorn the building. There are other views given, such as the North German Lloyd terminal pier at Hoboken and many hotels and apartment houses, and altogether the publication is well worth taking a look at, especially as you can get a copy free by applying to the Joseph Dixon Crucible Company for one.

The Danish Government is experimenting with automobiles for its mail service with the intention of largely extending the use of this type of vehicle should it prove satisfactory in a severe trial. The following conditions must be met before the automobiles will be purchased: The body of the car must be approved by the commission. It must accommodate sixteen passengers and be capable of carrying one ton of freight besides, at an average speed of 12 miles an hour on a 9 per cent. grade. It must run 1,243 miles satisfactorily after coming from the factory, with one of the commission acting as inspector on the trip. The commission is desirous of interesting American manufacturers of omnibus automobiles.—*Consular Report.*

The Becker-Brainard Milling Machine Company, of Hyde Park, Mass., have issued a neat little catalogue, giving details of their exhibit at the World's Fair at St. Louis. The exhibit consists among other things of a No. 3 gear feed, new model,

plain milling machine and also the same tool arranged for individual electric drive, a pair of No. 5B plain horizontal milling machines, one belt driven and one electrically driven, a No. 2 gear feed universal milling machine and a 36 in. automatic gear cutting machine, a couple of 5B vertical milling machines, one belt driven and one with motor drive; two No. 3 vertical milling machines, motor and belt drive; two No. 1, 14 in. cutter and reamer grinders, belt and motor driven, and a motor driven planer type milling machine 26x32 ins. x 10 ft. long. This firm will be happy to send this descriptive catalogue to anyone who is interested enough to apply to them for it.

The Firemen's Souvenir.

A very beautiful souvenir has been got out by the Brotherhood of Locomotive Firemen, in commemoration of their thirty-first anniversary, and ninth biennial convention held in the city of Buffalo this year. The souvenir is in the form of what may be called an album of views, which are all splendid half-tones printed in tinted ink which gives to each an excellent photographic effect. Scenes in and about Buffalo and picturesque views of Niagara Falls, the rapids, the whirlpool, etc., are in this collection. There are twenty-four views in all. A very interesting descriptive article, dealing with Buffalo, is printed in the pages of the souvenir. An article on the Brotherhood follows, succeeded by one on the magazine, and lastly, one on the Ladies' Society.

The concluding pages give half-tone portraits of the officers. Those of Mr. J. J. Hannahau, grand master, and Mr. W. S. Carter, secretary-treasurer, appear first, followed by the vice grand masters and the others in order of rank. The officers of the Ladies' Society are also in evidence. Altogether, the souvenir is a work of art and is a most delightful memento of the Brotherhood's visit to the Bison City.

The Falls Hollow Stay Bolt Company have recently been receiving large orders from Norway for their hollow stay bolts. A curious thing about these stay bolts is that they are made of iron which originally came from Norway and was mixed in this country with a harder quality of iron, then returned to the land where it was mined and smelted.

The following circular, issued by the secretary of the Master Car Builders' Association and addressed to the members, has been received:

"At the last convention, the price for lumber in the freight car rules was changed from 2½ cents to 3 cents per foot, but no corresponding change was made in the passenger car rules. As this was

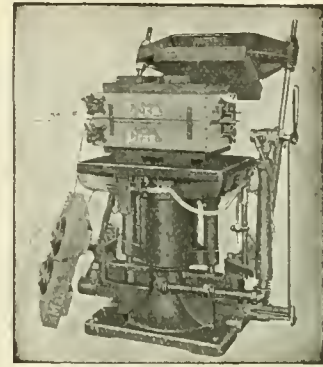

All Kinds of Molding Machines

Machines that ram
Machines that draw patterns
Machines that do both
Machines that strip patterns
Machines that vibrate patterns
Machines that do both
Machines for jar ramming deep molds
Power squeezers which do the work when you press a pop-valve
Machines which use compressed air and machines which don't

THE TABOR MFG. CO.

18th and Hamilton Sts.

PHILA., PA.

30-32 South Canal Street
CHICAGO, ILL.

84 Mason Building
BOSTON, MASS.

40 Deansgate
MANCHESTER, ENG.

Fenwick Freres
PARIS

Schuchardt & Schutte
BERLIN

Patents.

GEO. P. WHITTLESEY

McGILL BUILDING WASHINGTON, D. C.

Terms Reasonable. Pamphlet Sent

The Union Switch & Signal Co.

Consulting and Manufacturing
Signal Engineers.

GENERAL OFFICES AND WORKS AT
SWISSVALE, PA.

DISTRICT OFFICES:

New York: Central Building, 143
Liberty Street.

Chicago: 1536 Monadnock Building.
St. Louis: Terminal Station.

Q and C Priest Snow Flanger

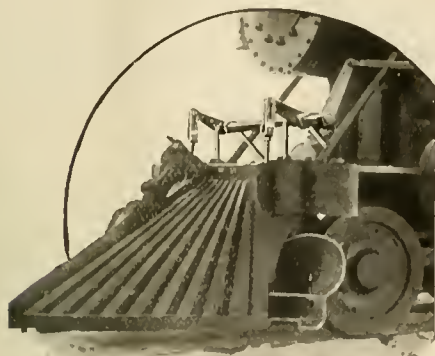

Order now. Don't wait till winter. Send for catalogue.

RAILWAY APPLIANCES CO.

OLD COLONY BUILDING, CHICAGO
114 LIBERTY STREET, NEW YORK

THE ROBERT W. HUNT & CO.

Bureau of Inspection, Tests and Consultation,
1137 THE ROOKERY, CHICAGO.
66 Broadway, New York. Park Building, Pittsburgh.
81 Norfolk House, London, Eng.

Inspection of Steel Rails, Splice Bars, Railroad Cars,
Wheels, Axles, etc. CHEMICAL LABORATORY—Analysis
of Ores, Iron, Steel, Oils, Water, etc. PHYSICAL LABO-
RATORY—Test of Metals, Drop and Pulling Test of Cou-
plers, Draw Bars, etc.

Efficiency Tests of Boilers, Engines and Locomotives.

evidently an oversight, I am directed by the Arbitration Committee to give notice to the effect that the price for lumber per foot in the passenger car rules should be 3 cents instead of 2½ cents, in order to make it conform to the price given in the freight car rules."

The Railway Appliances Company, of Chicago, have issued an illustrated catalogue showing the Oldsmobile railroad inspection car. This is really a railroad automobile, and it is driven by a 4½ h.p. gasoline motor. It weighs in all about 800 lbs. The body is of comfortable design, with full leather upholstered seats, and a seating capacity for four persons. A speed of about 35 miles per hour can be had, and the fact that a reverse action may be quickly made adds to the convenience and safety of these cars when used on steam roads. The Railway Appliances Company, Old Colony Building, Chicago, will be happy to send a copy of this catalogue to anyone who is interested enough to write to them for one.

The Great Western Railway of England have, by order of the courts, been temporarily restrained from drawing water from the river Tone at Taunton. The action at law was brought by the mill owners of that region on the ground that the abstracting of large quantities of water by the railroad which was used in supplying track tanks or troughs, so diminished their customary supply of water as to interfere with the operation of the mills. The decision, as it now stands, affects long distance runs without stop to and from the West of England. An appeal is likely to be made by the railroad on an interesting legal point, as they draw water from a canal which they themselves own and which is filled from the Tone river by authority of an act of parliament.

The Laidlaw-Dunn-Gordon Company, of Cincinnati, Ohio, have issued their bulletin, L 601, which deals with Meyer gear pumping engines, cross compound, triplex compound, fork frames and rolling mill frame high-duty pumping engines. The various pumps made by this concern are illustrated by clear halftones with explanatory letter press accompanying. Methods of compounding, the valve gear, frame construction and details of parts are all taken up in due course, and a list of prominent manufacturers and others who use these pumps, together with the daily capacity of each pump, are given. Write the company if you would like a copy of the catalogue.

According to the *Engineer* a new process for hardening iron has been developed by two Prussian inventors. It

consists in adding to iron a small percentage of phosphorus combined with a large amount of carbon. The iron is heated in a tempering powder consisting of bone dust, to which is added 300 grains of yellow prussiate of potash, 250 grains of cyanide of potassium and 400 grains of phosphorus. The receptacle is closed with clay and the temperature is raised to a clear red or white heat. The material treated is then taken out and plunged, while still hot, into a warm bath. It is claimed that this will harden the surface of a piece of iron weighing 400 pounds to a depth of about 0.04 inch, and that the iron can neither be cut nor chipped by the best steel used and that it can be readily welded.

Jenkins Brothers, of New York, manufacturers of valves have just issued a neat little booklet called *Valve Troubles and How to Avoid Them*. The first part of the booklet is devoted to a summary of the difficulties—if any—commonly encountered in the installation and use of valves, together with some suggestions for the remedy of such difficulties. The latter part is devoted to the illustration and description of the principal types of valves manufactured by Jenkins Brothers. The first valve illustrated is the regular Jenkins Brothers brass globe valve, which is the type of valve most extensively used to-day. The extra heavy brass valves are next shown, these valves being designed for a working steam pressure of 150 to 300 lbs., or for hydraulic pressures up to 1,000 lbs. The booklet is illustrated with half tones throughout, and special attention is called to the transparent cut of the "Excelsior" straightway back pressure valve, showing at a glance the simplicity and advantages of this valve. The description of the Jenkins Brothers safety valves is also noteworthy. This little catalogue will be sent free to any address on application to Jenkins Brothers.

The National Electric Company, of Milwaukee, Wis., has just issued their Bulletin No. 350, in which stationary and portable motor driven air compressors are described and illustrated. These machines are for continuous or intermittent service, Types "H" and "L" being shown in excellent half tone illustrations first with motor removed, the motor separately and with both together in place, also with caps removed showing field and bearings. The automatic governor is illustrated and explained. Then comes portable types with compressor, motor and storage tanks carried on a handy truck which can easily be moved about a shop. Hose and wire connections can be attached as required. Write to the company for this bulletin if you desire to know something about these useful and handy machines.

COM-PRESSORS PNEUMATIC TOOLS ROCK DRILLS

CUT OUT

this Ad., fill in your name and mail to us, and we will send you printed matter from time to time as it comes off the presses. It may be convenient for you to be among the first posted.

Mr. _____

RAND DRILL CO. 128 BROADWAY N.Y.

A. O. Norton, manufacturer of ball-bearing ratchet screw jacks and sure drop track jacks, has issued a neat little folder, on the front page of which is a picture of a pretty girl in the act of putting a ring on the third finger of her left hand, and the title of the folder is "An Attractive Proposition." On the next page some good half tone illustrations of the Norton ball bearing jacks are given and a few words concerning the length of trial allowed and the amount of discount given. The folder sets forth and illustrates an attractive proposition in more ways than one.

The Pennsylvania Railroad is about to return to the "one man one engine" system on the middle division, and thus be enabled to draw conclusions between the cost of operation of engines so run and the cost under the pooling system. Many prominent motive power men throughout the country do not believe that the time allowed to engines at terminals is as long as it ought to be, and that therefore the roundhouse force, always on the rush, is not able to do work as thoroughly as it should be done and although the rapid turning of engines looks remarkably well on paper, yet the record between shoppings often shows that much has been sacrificed in order to reduce the "lay over" time to the lowest possible number of minutes.

A little booklet bearing the words "About Plastic Metallic Packing," from the Plastic Metallic Packing Company, of Pittsburgh, Pa., has recently come to hand. It explains what plastic packing is, how it is used and how sold, and a list of letters of endorsement from prominent firms who have tried the packing, are given. Write to this Pittsburgh firm for a copy of the little pamphlet if you are interested, and the company will be happy to communicate with you.

New sleeping cars, bought at an expense of \$700,000 and placed in service on the Twentieth Century Limited of the New York Central-Lake Shore route, embody the latest design and improvements of the Pullman Company. These include the changing of seats so as to give storage room for satchels and packages, reduction of space for upper berths, and the enlargement of the dressing room. From a hygienic standpoint the new sleeping cars are a great improvement over the former models. The manner in which the upper berths fold up increases the area of the car to a marked extent. An idea rigidly adhered to in finishing any furnishing of the cars was to eliminate everything which might collect dirt or germs.

Huxley's dominant note was the love of knowledge, an ever present, never satisfied desire to know.—*Sir M. Foster.*

Portable Frame Forge.

A very interesting portable frame forge is used in the Pittsburgh repair shop of the Pennsylvania Lines West. It is intended for localizing the heat when welding a broken frame in position, the idea being that in doing such work the smaller the area heated the better, and consequently the less expansion produced the better.

The forge is about 2 ft. square and the upper portion marked A in our illustration is hinged at the back and notched out so as to enclose the frame. It can be tilted up when it is desired to place it over a broken frame. It is not possible to reach every portion of a locomotive frame with this forge, but there has been enough use for this crane to justify its existence.

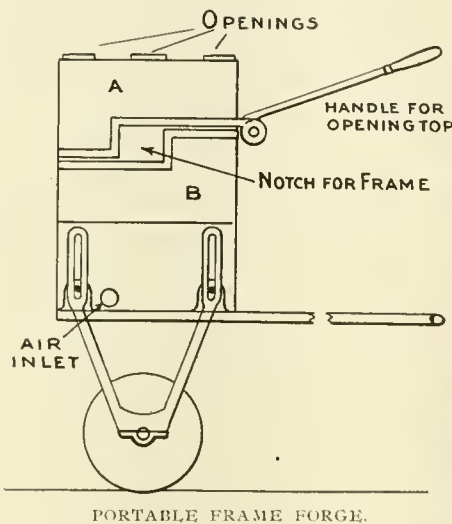

PORTABLE FRAME FORGE.

The forge is made of fire brick bound with flat iron and the interior is lined with fire clay. Grate bars extend across the full width of the lower chamber B, but part of these can be covered with fire brick when it is desired to reduce the heated surface to a minimum. Openings on top permit the gases of combustion to escape, and as the notch in the furnace closely fits the frame, there is not much flame and gas blown out sideways.

The whole forge can be raised or lowered to suit circumstances, as it is supported by four studs which slide in the slots of the upright carrying bars which rest upon the axle. Air is supplied through a suitable opening and a connection is in place to which the shop air hose can be applied. The air jet is made on the injector principle and, therefore, only a small quantity of compressed air is actually used while atmospheric air is drawn in all round the central jet.

The shop men and the officials say that this is a most useful shop appliance and that it can do its business thoroughly wherever it can be applied.

**The BARRETT
GEARED RATCHET CAR
JACKS**

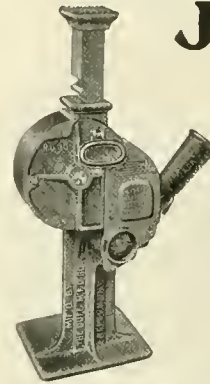

No. 29 25 Tons Capacity.
No. 30 35 Tons Capacity.

IMPROVED QUICK ACTING JACKS

for the rapid handling of Empty Cars and Coaches and for Locomotives.

Easy to Operate. and they have no intricate parts or complicated features. Have all the simplicity of the ordinary Lever Jack, and are more reliable and better adapted to car work than either Hydraulic or Screw Jacks.

Send for Special Bulletin "L"

MADE ONLY BY

THE DUFF MANUFACTURING CO.

Works: Allegheny, Pa. PITTSBURG, PA.
FAIRBANKS, MORSE & Co., Chicago,
Agents for Railroad Dept.

**Handy Folding
PILOT COUPLER**

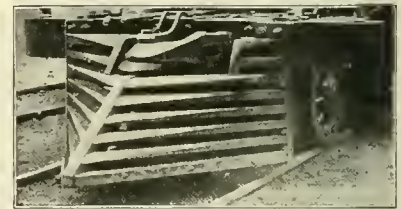

A safe and neat construction for front ends of road locomotives

Handy Car Equipment Co.
Old Colony Building
Chicago

CONTENTS.

	PAGE.
Air Brake Department.....	457
*Boiler Tube, The Coming Cold Drawn.....	469
*Cylinder Saddle Repair Job.....	474
*Drop Forge, A Handy.....	466
Editorial.....	
American Railway Appliances Exhibition at International Railway Congress.....	452
*Piston Packing.....	452
Prof. Goss on Compound Locomotives.....	450
Proposed 100-mile-an-Hour Railway.....	452
Value of Newspaper "News".....	453
Victory for the Brotherhoods.....	451
Firemen's Convention at Buffalo.....	456
*Forge, Portable, for Frames.....	480
General Correspondence.....	441
*Lathe, New Car Wheel, Pond.....	468
Locomotive:—	
*Growth of the, by Angus Sinclair.....	437
Improvements on.....	470
*Instruction Car, N. Y. Interborough.....	447
*2-6-2 for Lake Shore.....	440
*4-4-2 Balanced Comp. for the "O".....	465
*4-4-1 for the Prince Edward Island Railway.....	471
*Mount Pilatus Railway.....	435
*Oil Delivery Valve, A Positive, by J. A. B.....	462
Personals.....	467
Pop. and Relief Valve Tester.....	466
*Russia's Only Building at St. Louis.....	475
*Screw Thread Rolling Machine.....	477
*Shop Turntable, A Handy.....	472
*Signals and Signaling, by Geo. S. Hodgins.....	455
Stories and Narratives:—	
*Expensive Conflict of Authority.....	448
*Stud, Extracting Broken, by J. Kennedy.....	471
Traveling Engineers' Convention.....	476
Volume of Air to Sustain Combustion.....	464

Railway and Locomotive Engineering

Copyright by Angus Sinciair Co.—1904

A Practical Journal of Railway Motive Power and Rolling Stock

Vol. XVII.

136 Liberty Street, New York, November, 1904

No. 11

The Simplon Tunnel.

The Simplon tunnel in Switzerland, when within a few months of completion, received a serious though temporary setback. The tunnel was flooded

workmen were leaving the tunnel and had not been fully relieved by the day force. The heat coming from the boiling water is so intense as to be dangerous to the workmen. It is only by

and when completed it will shorten the rail journey between Paris and Milan by eight hours. The tunnel is 1,500 ft nearer the sea level than the St. Gothard tunnel and is 2,000 ft lower than



VIADUCT SAINTE MARIE ON CHAMONIX RAILWAY, SWITZERLAND.

by the bursting forth in its interior of a subterranean spring of boiling water which was estimated to be flowing at the rate of 1,500 gallons a minute.

That fearful loss of life did not take place was due to the fact that inundation occurred when several hundred

sprinkling them constantly with ice water that work can be carried on at all, and although a constant flow of fresh air is of course maintained, work is very slow, and many of the tunnelers have succumbed.

The Simplon tunnel is 12 miles long.

the Mont Cenis, and this helps to account for the Simplon's greater length, as it is 2,312 ft. above sea level. The St. Gothard is something over 9 miles and the Mont Cenis is slightly less than 8 miles long. In point of construction the shorter tunnels took longer to drive,

This is no doubt owing to the greater perfection of modern tunneling machinery and appliances and to the general advance in engineering methods. The Mont Cenis tunnel took 13 years, the St. Gothard seven and the Simplon, with greater mileage and probably offering more obstacles than either of the others, has been driven through in five and a half years.

The rate of progress in the Simplon pass was on the northern side, about 20 ft. daily, and 16 ft. on the southern

side, the rock at the southern end being much harder than that at the north. The total amount of dynamite used is estimated at over 2,000,000 lbs. What we constantly speak of as the Simplon tunnel is really two parallel single track tunnels about sixty feet apart. In the center for a distance of about 425 ft. the intervening portion of rock between the tunnels has been broken away and the huge subterranean hallway between them has been used to facilitate the ventilation of both tubes. The comparatively low level of the tunnel has permitted the approaches to be made of easy grade, which in time to come will have a marked effect on the cost of transportation on the Jura-Simplon Railway. The bursting of the boiling spring in the tunnel will probably delay its opening several months or until the water has all been drained off.

The Canadian Pacific have been contemplating the training of guides capable of taking hunting and camping parties in hand. Mr. L. O. Armstrong, colonization agent for the Canadian Pacific Railroad, recently said when speaking of the kind of man suited for this particular kind of work: "Not only must the guide be a good canoeist, but he must be able to cook for and cater to the wants of wealthy people. The Hudson Bay Company has trained many such men, and many have become expert in this line through caring for the wants of railway men during periods of construction. But these do not constitute sufficient numbers."

The men who notice things have been a powerful element in moving the progress of civilization. One day many years ago a young man was attending church in an Italian city and he noticed that a lamp hanging by a long cord was oscillating steadily from side to side. The

youth, whose name was Galileo, got cogitating about the possibility of utilizing the synchronous movement in mechanics and therefrom he conceived the idea which led to the invention of the pendulum and all the resulting improvements on clocks.

A Quick Lunch Car.

"Circumstances alter cases" is an old adage, and the realization of its true meaning has led the general passenger agent of the Pere Marquette Railroad,

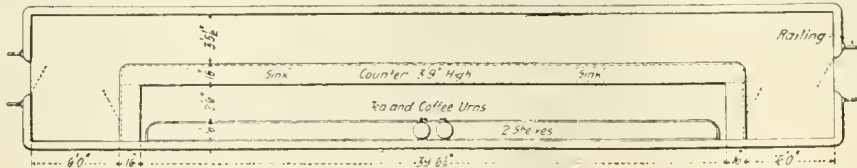

PLAN OF PERE MARQUETTE LUNCH COUNTER CAR.

Mr. H. F. Moeller, to introduce a lunch counter car on certain trains running on the road with which he is connected. The car is reported to be a complete success.

In the summer months the Pere Marquette have to handle a heavy passenger traffic out of Chicago to the various popular resorts in Michigan. Mid-day trains out of Chicago on Fridays and Saturdays are well patronized, the return traffic on Sunday being quite heavy. Formerly café cars in which a meal was

car and leaves a passage 3 ft. 5 1/2 ins. between it and the side of the car. A space of 6 ft. is left at each end and the space behind the counter is closed off by two end counters facing the doors. The length of the line along the outside of the counter, together with its two end extensions, gives a little under 50 ft. where patrons may stand. It seems to us that this 50 feet of length might not inappropriately be called the "feeding surface" of the cars and at present it appears to be able to fill a long felt want. About sixty persons can stand along and about the counter, and the car will hold from about 150 to 200 people.

All the woodwork is pine, stained and finished to match the rest of the car. The top of the counter is walnut, and all the usual dairy lunch counter accessories are present, and prices are moderate. The cars run from Chicago to Hartford, Mich., giving nearly three and a half hours in which business is rushing, not only along the track of the Pere Marquette, but over the counter of the quick lunch restaurant on wheels.

At the recent annual convention of the Master Car and Locomotive Painters' Association the following officers were elected: President, Mr. J. F. Lanferseik, Pennsylvania Railroad, Columbus, O.; first vice-president, Mr. H. M. Betts, New York Central, West Albany,



PERE MARQUETTE LUNCH COUNTER CAR

served à la carte were run on these trains, but during the week end rush traffic it was found impossible to serve all those who sought refreshment while traveling.

To meet this emergency which was the circumstance which altered the case, an old passenger car was converted into a traveling restaurant in which a dairy lunch is quickly and satisfactorily served. A counter 3 ft. 9 ins. high, 16 ins. wide and about 42 ft. long occupies one side of the

N. Y.; second vice-president, Mr. J. H. Kahler, Erie Railroad, Meadville, Pa.; secretary-treasurer, Mr. Robert McKeon, Erie Railroad, Kent, O.

Cotton weaving has done more for the United States within the last century than any one other industry. The Indians of Central and South America have for centuries used a loom so elaborate that ours is, comparatively speaking, but a slight improvement upon it.

4-6-2 Engine for the Missouri Pacific.

The engine here illustrated is an example of a 4-6-2 type engine belonging to the Missouri Pacific Railroad System, of which Mr. J. W. Luttrell is superintendent of locomotive and car department. It was built at the Brooks shops of the American Locomotive Company, and is at present on exhibition at the Louisiana Purchase Exposition.

The cylinders are 20x26 ins., and the diameter of the driving wheels is 69 ins., and, with 200 lbs. working pressure, the maximum tractive power is 25,625 lbs. The total weight of the engine is 183,200 lbs., of which the drivers carry 122,000 lbs., the engine truck 35,200 lbs., and the rear carrying wheels 26,000 lbs. The driving wheels and those of the rear truck are all equalized together, with cast steel equalizers between each pair.

The pistons drive on the center pair, and the valve motion, which is direct, actuates 11-in. piston valves. The shifting links are made of cast steel. The driving wheels are counterbalanced after

proportioned. A few of the principal dimensions are appended for reference:

General Dimensions—Weight engine and tender in working order, 290,200 lbs.; wheel base, driving, 12 ft. 4 ins.; wheel base, total, 31 ft. 8 ins.; wheel base, total, engine and tender, 55 ft. 1½ ins.

Cylinders—Size of steam ports, 1½ ins. x 25½ ins.; size of exhaust ports 50 ins.; size of bridges, 3 ins.

Valves—Greatest travel of valves, 5½ ins.; outside lap of valves, 1½ ins.; inside lap of valves, 0 in.; lead of valves in full gear, ½ neg.

Wheels, etc.—Dia. and length of driving journals, 9 ins. dia. x 12 ins.; dia. and length of main crank pin journals, 6¼ ins. dia. x 6½ ins.; dia. and length of side rod crank pin journals, 7 ins. dia. x 4½ ins.

Boiler—Thickness of plates in barrel and outside of fire box, ⅜, ¼, ¼, ⅞, ½, ½ in.; fire box, length, 78 ins., width, 80 ins.; depth, front, 74 ins., back, 63 ins.; plates, thickness, sides, ⅜; back, ⅜; crown, ⅜; tube sheet, ⅝ in.; fire box, water space, front, 1 ins.; sides, 3¼ ins.; back, 3¼ ins.

American Locomotive Company's Report.

The third annual report of the American Locomotive Company for the year ending June 30, 1904, has just been issued. It is

manufacture of thirty electric locomotives, to be delivered by 1906. The American Locomotive Company will construct the mechanical parts of the locomotive, the General Electric Company supplying all the electrical apparatus.

Primitive Elevators.

The practice of climbing up telegraph poles by means of a spur-like arrangement attached to the shoes of repairers was practiced in a modified form long before the electric telegraph was invented. The same mechanical principle has been followed for centuries by the bee hunters of the Island of Timor and others of the Malay Archipelago.

To get at a honeycomb seventy feet overhead, with nothing between it and the ground but a smooth and branchless trunk, seems at first sight impossible without ladders or ropes. It is a simple matter to the Polynesian. He cuts a few yards from the tough stem of a creeper and forms of it a bush rope. With this he makes a loop around the trunk and



J. W. Luttrell, Supt. Loco. and Car Dept.

4-6-2 LOCOMOTIVE FOR THE MISSOURI PACIFIC.

American Locomotive Co., Builder.

the Davis system, the main driver necessarily having the heaviest weight.

The boiler is of the radial stay type with wide fire box. It measures 64 ins. outside diameter at the smoke box end. The crown and roof sheets are level with steam and water space of about 22 ins. The back sheet slopes 22½ ins. and the throat sheet slopes 17¼ ins. The heating surface in the tubes amounts to 2,778 sq. ft., and the fire box contributes 152 sq. ft., making a total heating surface of 2,930 sq. ft. The grate area is 42.9 sq. ft. There are 256 tubes in the boilers, each 18 ft. 6½ ins. long. The boiler is supplied with water by two No. 10 Monitor injectors.

The tender weighs, when empty, 44,720 lbs., and has a steel channel frame. The tender trucks are of the ordinary arch bar type with Player holsters. The tank capacity is 5,000 U. S. gallons of water and 10 tons of coal. The engine presents a very symmetrical appearance, and is well

printed in standard pamphlet form. The views of the different shops of the company's works are most artistically represented, the artist employed has been at much pains to reproduce a bird's-eye view giving an accurate and comprehensive view of the several properties. The latest types of engines turned out by this company are given in excellent half-tones. An obituary notice of S. R. Calloway, late president of the company, appears on the last page.

During the past year the mechanical and electrical engineers of this company have been in frequent consultation, not only as to the general problem of the possible future application of electric power to steam surface railroads, but also in regard to a specific proposition for an electric locomotive suitable for use in the suburban traffic of one of the great trunk lines. After much study and in co-operation with the General Electric Company, agreements have been entered into for the

his body. Jerking the loop a little above his head, he leans back and begins walking up, his bare feet pressed against the trunk. Repeating the operation he gradually gains the top. The whole ascent is made without exhausting use of muscles by utilizing the principle of friction

We should never have had the Panama hat but for the quick fingered Indians of the Isthmus of Panama. Even to-day their secret process of seasoning the grass blades used in weaving these hats remains unrivaled. Basket makers of the same region make baskets which hold water without leaking—another invention which is quite beyond us

It is easy to be good when there is no temptation to be bad. Many a saintly life follows the path of righteousness because the entrance to the other path was never encountered

Growth of the Locomotive.

BY ANGUS SINCLAIR.

(Continued from page 439.)

INCREASING THE WEIGHT AND POWER OF LOCOMOTIVES.

Ever since the first section of railway was put in operation, there has been a steady movement towards making the locomotive equipment more powerful. The tendency has at times paused for a few years, people claiming that the economical limit of weight and power had been reached, then it would start again and a belief now prevails that the final limit is an engine that fits the restricting gauge of bridges and tunnels and cannot be made any larger unless the openings through which it has to pass are made wider and higher.

RESTRICTIONS OF THE IRON RAIL.

The first restriction encountered to the growth of the locomotive was the comparatively fragile iron rail. The iron rail wore so rapidly and laminated so badly under heavy or sharp wheel impact, that the prudent railroad manager generally restrained other officials in their zeal to increase the hauling power and, therefore, the weight of locomotives. Motive power officers would argue that they could make heavy engines that would impose no more weight or force of impact upon the rails than lighter ones because more wheels were employed in carrying them; but the

could afford to build and maintain very substantial permanent way and very heavy rails, but this was not the case with ordinary railways.

Until steel rails were introduced the subject of wear of rails was one of ex-

laden iron rails prepared the way for the rapid introduction of steel when its day arrived.

RELATIVE WEAR OF IRON AND STEEL RAILS.

Engineers who have made the subject of rail material a special study, say that under the same conditions of road bed and rail section, a good steel rail is about 20 times more durable than a good iron rail of the same section and is less liable to breakage during the whole of its life.

POLITICAL EFFECT OF CHEAP RAILS AND HEAVY LOCOMOTIVES.

The invention of cheap methods of making steel rails has exerted a tremendous effect upon railroad transportation, and has created social revolutions in certain parts of the world. It brought the cereals of regions west of the Missouri river, and of the remote northwest, into competition with the grain raising districts of the Eastern States and with those of Europe and Asia. It threw many farms in New England and along the Atlantic seaboard out of cultivation; it caused a semi-revolution in farming business in the British Isles, and strongly affected the condition and fortunes of millions of people in other countries. Irish peasants used to go in thousands to England and Scotland to work in the harvesting of the grain crops and thereby earned enough money to pay the rent of their small holdings. Steel rails and



DR. COLEMAN SELLERS,
Pioneer Locomotive Builder. Was Superintendent of Niles Locomotive Works, Cincinnati.

traordinary solicitude to railway managers.

INTRODUCTION OF STEEL RAILS.

Steel rails began to come into use in the United States about 1867 and they very quickly pushed iron rails out of demand. This was not so much that the first steel rails had proved decidedly superior to good iron, but because the makers of iron rails had come habitually to lower the quality of their product. An expert rail maker testified before a committee of the House of Commons, which was investigating complaints about inferior rails being supplied to the railways of India, that the first question asked him by the chief di-

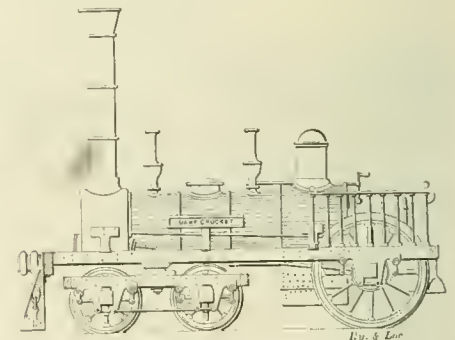

FIRST ENGINE ON SCHUYLKILL & SARATOGA RAILROAD.
Built by R. Stephenson & Co.

Consolidation locomotives stopped the cultivation of so many wheat fields in the British Isles, that the help of the Irish worker was no longer needed, and the suffering and discontent arising therefrom led to the vigorous agitation for home rule in Ireland.

The woes of Ireland were merely the preliminary manifestations of hardships inflicted through the grim ordeal of competition worked out by our cheapened methods of land transportation. The locomotive, now becoming common, that hauls a train weighing 3,500 tons containing 90,000 bushels of wheat, the product of 3,000 acres, is steadily forcing more grain raising farms of Europe out of cultivation and is raising a demand for protection against cheap land, just as our

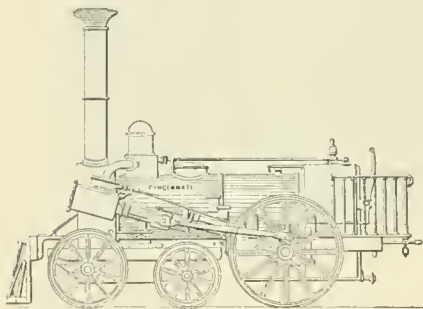

NILES LOCOMOTIVE WORKS, ABOUT 1845.

permanent way department complained habitually about the destructive effects of heavy locomotives, no matter how many wheels they might have, and the roadmaster's complaint was listened to more readily than the master mechanic's theories about the action of lightly loaded driving wheels.

THE INFERIOR IRON RAIL.

There were cases where the demands for moving a heavy volume of freight business were so imperative that the rapid wear of rails received little consideration. The coal carrying railroads of Pennsylvania, Maryland and New York, which frequently received more business than their motive power could handle, began about the middle of last century to use engines which were extraordinarily heavy and powerful for that time. The companies using such engines

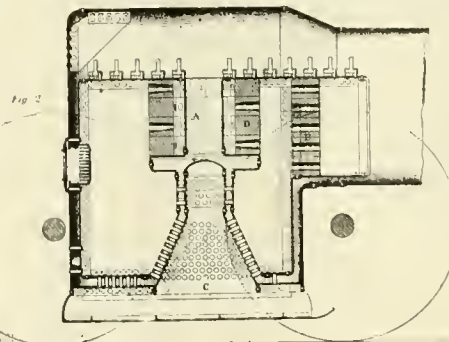

YATES FIRE BOX. FIG. 73.
Used on Buffalo & Lake Huron Railway.

rector of a rail making company with which he was negotiating to take the position of superintendent was: "How much slag can you work into a rail?" The slag

politicians have so long urged the necessity for protection against the cheap labor of Europe.

About 60 years ago Great Britain abolished all duties on grain which was the most important action towards free trade. By curious reasoning the statesmen believed that this policy would not only make the British Isles the manufacturers of the world, but that it would increase the prosperity of the agricultural

RATES IN CENTS PER BUSHEL OF WHEAT AND CORN FROM CHICAGO TO NEW YORK.

Year.	WHEAT.		CORN.	
	By rail.	By rail and water.	By rail.	By rail and water.
1870.....	26.11	19.58	24.37	19.32
1880.....	19.8	15.8	17.48	14.43
1890.....	14.3	8.52	11.36	7.32
1900.....	10.8	...	10.1	...
1904.....	11.4	...	10.6	...

The effect of that cheapening of transportation in the United States has been

a multitude of people, but their misfortune has been small compared to the benefits conferred upon the many by the invention of Bessemer steel and the development of the hundred ton locomotive.

(To be continued.)

Traveling Engineers' Convention.

SECOND DAY.

The first paper presented was that on the water tube, and upon request of Mr. F. P. Roesch, the author, the paper was read by Mr. Wallace. A lengthy discussion followed the reading of this paper, and the general opinion seemed to be that the water tube, as far as it applied in supporting the brick arch, was a good thing, providing it was kept clear of sediment and tight in the sheets. Several instances were cited where the arch supporting water tubes had burst, severely injuring the fireman and in a few cases blowing him from the engine and resulting in his death. The paper gradually drifted into the discussion of the merits of the brick arch which was pretty thoroughly aired and the discussion closed with the consensus of opinion that both the brick arch and the water tube, while susceptible of improvements, was a good thing in fire boxes properly designed to carry a brick arch.

There seemed to be a difference of opinion in the advantage of the brick arch, members on one division getting splendid results from the brick arch and water tube while members on an ad-

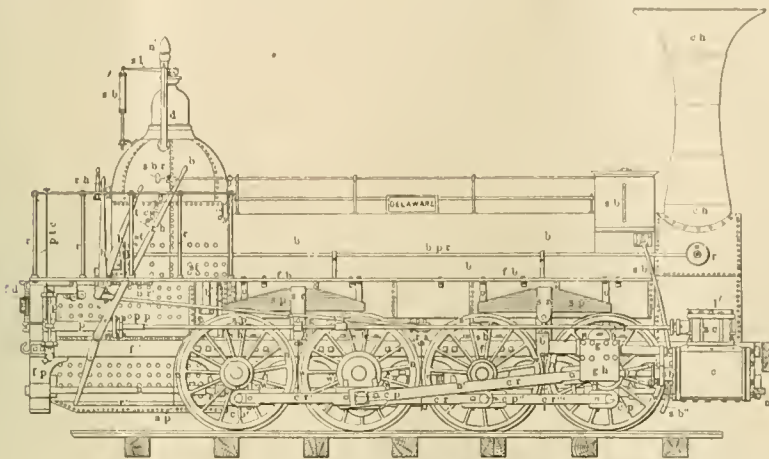

WINANS' DELAWARE.

communities as well. The first thirty years' experience of free corn did not seriously challenge the correctness of the free trade theory, for most of the American wheat lands were yet unbroken prairie or virgin forests, and our steel rail makers and locomotive builders were merely getting ready.

In 1850, shortly after the British corn laws were abolished, the leading agricultural States of the Union raised 63½ million bushels of wheat and 281 million bushels of corn and there were 8,571 miles of railways. In 1870 the principal wheat raising States produced 141 million bushels of wheat, and the leading corn States raised 383½ million bushels of corn. The railroad mileage was 49,168. One decade later the wheat raised in one year was 214½ million bushels and 1,030½ million bushels of corn. The railway mileage had increased to 87,724. In 1899 the wheat produced in the leading States was 234 millions of bushels; the corn amounted to 1,114 millions of bushels.

EFFECT OF STEEL RAILS ON FREIGHT RATES.

Freight rates have been steadily reduced with the improvements in railroad rolling stock and permanent way. In 1858 the rate per bushel of wheat from Chicago to New York was 38.61 cents. The rate to-day is 11.4 cents. The distance from Chicago to New York is about one thousand miles. The following table will give an idea of rail rates per 1,000 miles haul, and it applies to the whole American continent:

very disastrous to Great Britain, for during the last thirty years there had been a shrinkage of 3,000,000 acres in wheat and another of 750,000 acres in green crops; an enormous amount of land had reverted to pasturage; the diminution of stock had been 2,000,000 head; the reduction of farming capital

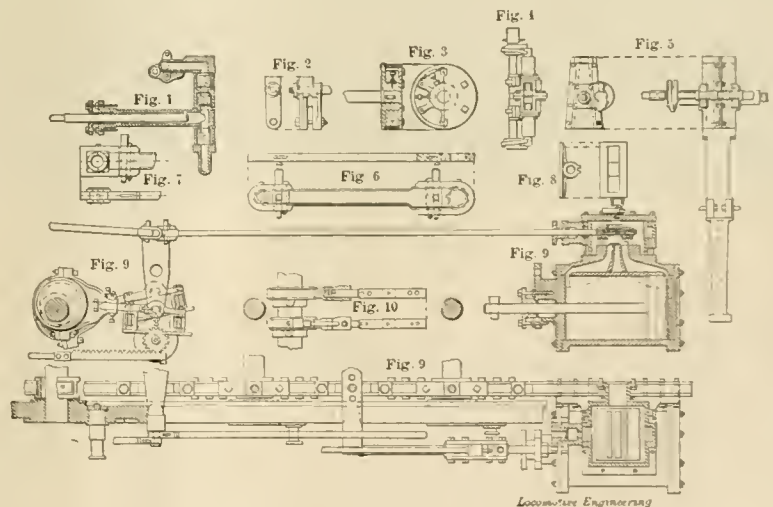

DETAILS OF WINANS' DELAWARE.

had been \$200,000,000; and the number of cultivators of the soil had declined 600,000 in thirty years—1,000,000 in fifty years.

That is a high price to pay for the devotion to a theory which fails to work out as expected.

The cheapening process represented by these figures involved changes that caused terrible affliction and suffering to

joining division on the same engine equipped with an arch had entirely satisfactory results when the arch was removed. One member had achieved a gain of 11 pounds of coal per 100 ton mile with the tubes and arch removed. Another member had effected a saving in fuel of about 10 per cent. with the engine equipped with water tubes and brick arch over the same engine with

the water tubes and brick arch removed. It seemed that different sections of the country required brick arches, while others did better without them.

Some members believed that the use of the brick arch prevented the cracking of the door sheet and the honeycombing of the flue sheets. One member was quite decided in his views on the advantages of the brick arch, and described at length how it caused the gases to mingle more perfectly with the admission of the air, resulting in better combustion and the consumption of the fire box gases, which otherwise pass through the flues and out the stack, a dead loss. One member complained that on his road considerable difficulty was experienced with the water tube arch bars pulling out of the sheets, although the tubes had been well rolled in the sheets. One member believed that the honeycombing of the flue sheet was due more to the fireman than to the use or the non-use of the arch. Another member found that the flue sheets had to be cleaned oftener when the brick arch was not used than when it was used. Another member believed that honeycombing was due to imperceptible small leaking.

Mr. Hubbell then presented his paper on the Hubbell Valve Motion, after which the members were invited to ask such questions regarding the device as they might wish, and Mr. Hubbell answered them. A number of questions were submitted and cheerfully and effectively answered by Mr. Hubbell. The whole discussion brought out the fact that in abolishing clearance in the steam ports of the cylinder a much better performance of the engine would be had as well as a better use and distribution of steam, due to the peculiarities of Mr. Hubbell's gear.

A member from the Pierre Marquette stated that three engines equipped with Mr. Hubbell's valve gear had been running on that line since November 1, and during that time all three engines had not been out of service more than two weeks altogether. He further reported that the engines run 20 per cent. farther with the same load on one tank of water. He firmly believed there was a saving of 20 per cent. in fuel and water. The company and engineers of these engines seemed very well pleased and satisfied with their performance.

After the session the members participated in a tally-ho ride round the city and reported a very enjoyable time.

THIRD DAY.

The secretary read a dispatch from Mr. Angus Sinclair of RAILWAY AND LOCOMOTIVE ENGINEERING, expressing regret on his inability to be present at this meeting, his presence being needed elsewhere on account of pressure of business matters. A letter from Mr. W. H. Whalen, superintendent of the Iowa

division of the Chicago & North Western Railroad was read. He mentioned the importance of the road foreman of engines being thoroughly familiar with the practical conditions of the equipment, road operations, etc. He urged that the recommendations of the road foreman be recognized by the higher officials.

A paper on "High Speed Brakes" was read by the author, Mr. L. M. Carlton, general air brake inspector of the Chicago & Northwestern Railway. The question of higher train line pressure was also discussed. The past year had developed the fact that better lubrication was necessary for triple valves in high speed brake service than was required for the 70 pound brake. It was also brought out that greater care in the piping of air pumps and main reservoirs on locomotives was necessary with particular view to eliminating the moisture from the train pipe and valves, the moisture gathering in the triple valve and freezing the slide valve to its seat, thus resulting in undesired quick action. Mr. Carlton laid great stress on the importance of the two application method of making stops, thereby producing smoother stops and lessening the number of slid flat wheels.

Mr. Meadows then read the report of the committee, which attended the Master Mechanics' Convention in Saratoga Springs last June. This paper was a report of the proceedings of the Master Mechanics' Convention briefly and concisely arranged.

The paper on "Electric Head Lights," by Mr. A. L. Beardsley, of the Santa Fe road, was then read by the author. A spirited discussion followed the reading of this paper and the subject of electric headlights was thoroughly aired.

The question of confining the electric ray to a narrow portion of the track ahead was discussed. Some believed that the rail should be distinctly visible, and that a certain portion of the right of way on the side of the track should also be distinguishable, also that the ray, while carrying as far distant as possible, should strike the track as near the front of the engine as consistent, for better illumination on curves and in railroad yards. The location of the dynamos for the headlight brought forth considerable discussion and recommendations for its location between the stack and the headlight, and between the cab and the dome, were nearly equally divided, but preference lying slightly with the position directly in front of the cab, owing to the accumulation of less dirt and the necessity for the shorter length of steam pipe.

The breaking of the headlight glass was another subject which consumed a considerable portion of the discussion. The various methods of fastening the glass to the headlight box by rubber at-

tachments, wooden attachments, etc., were discussed. One man believed that the breakage of the glass was largely reduced by the use of separate strips of glass in the headlight. Other members had experimented with the setting forward or setting back the arc with a view of reducing the heat upon the center of the glass which was believed to be the direct cause of the greater number of glass breakages. It was believed that a better quality of glass was necessary for electric headlights, as the ray striking the center of the glass would heat it to a high temperature, while the outer edges of the glass would remain cool, thus causing a breakage.

FOURTH DAY.

The discussion of electric headlights was resumed along the same lines as that of the preceding day and after a short discussion the paper was accepted and the room prepared for a stereopticon lecture on the Baldwin Compound Engine, by Mr. Carroll. Much attention was given to the Baldwin Balanced Compound, which is now superseding the older form of Vauclain type. The lecture was very interesting and instructive. Following Mr. Carroll, Mr. Vauclain took up the same subject and went more into detail than Mr. Carroll had done. This exceedingly interesting lecture closed the business of the convention with the exception of the election of officers which resulted as follows:

President, J. D. Benjamin, Chicago & Northwestern Railway.

First Vice-President, A. L. Beardsley, Santa Fe Railway.

Second Vice-President, W. J. Hurley, N. Y. C. & H. R. Railroad.

Third Vice-President, A. M. Bickell, Lake Shore & Michigan Southern Railway.

Secretary, W. O. Thompson, N. Y. C. & H. R. Railroad.

Treasurer, C. B. Conger, International Correspondence School.

Executive Committee—J. A. Talty, Delaware, Lackawanna & Western Railroad; W. H. Corbitt, Mexican Central Railway; W. P. Steele, W. G. Wallace, Denver & Inter-Mountain Railway.

The Constitution was changed to give the Executive Committee the selection of the next meeting place of the convention. In order to guide the Executive Committee in this selection a vote of the members was taken as follows:

Denver, 31; Chicago, 16; Detroit, 8; Chattanooga, 8; Norfolk, 7.

It is probable that Denver will be the next place of meeting.

He that hath wife and children hath given hostages to fortune; for they are implements to great enterprises, either of virtue or mischief.—*Bacon*.

A New Indian Train de Luxe.

On Saturday, July 30, the Great Indian Peninsula Railway commenced running a special limited express or "train de luxe" between Bombay, the commercial capital of British India, and the favorite hill resort of Poona, the chief military center of the Empire. The putting into service of this train is the most startling innovation in Indian railway travel which has been introduced since railroading commenced in the country. Hitherto the majority of carriages in operation have left much to be desired; they are small, built on the compartment system and lack the many conveniences one is accustomed to when traveling under the modern conditions prevailing in Europe and America, and they are generally freely cursed by visitors from the West whether Brit-

have a free passageway throughout. The ugly sun awning of the ordinary Indian cars has been abandoned and a portion of the space gained in width thrown into the interior. There is an intermediate lining of nonconducting material introduced between the double roofs and sides to protect the interior from the heat of the sun. The form of roof adopted is similar to our standards but is lower in the "deck" owing to the present limited dimensions of the numerous tunnels on the mountain section which has to be traversed by all trains shortly after leaving Bombay city.

Restaurant car No. 2019 has gas cooking stove capable of supplying 50 dinners. A commodious kitchen, a compartment for native servants, store and pantry. The dining room seats 24 and is finished

falo hide, and a lady's boudoir equipped with sofas and easy chairs covered with blue morocco. The decoration throughout is in harmony with the furnishings.

The restaurant car is 56 ft. 10 ins. long and 9 ft. 6 ins. wide, while the parlor car is 62 ft. long over end sills and 10 ft. wide with doors set in to 9 ft. 6 ins. The large windows are balanced and all shutters and screens have automatic catches. Electric lights and fans are fitted in the parlor car the same as in the restaurant and a small gas stove is installed for tea and coffee, etc.

The distance between Bombay and Poona is 119½ miles and the train is scheduled to do the run in 3 hours. The course is divided into three sections owing to the interception of the Ghat inclines where the railway ascends the



4-6-0 ENGINE ON THE GREAT INDIAN PENINSULA RAILWAY.

ons or Yankees. In the new train all is altered; it consists entirely of first class cars and includes new vehicles just built at the Paul Shops, Bombay, from the designs and under the direction of our friend, Mr. A. Morton Bell, M. I. Mech. Eng., whose appointment to the post of carriage and wagon superintendent or master car builder we recorded in our February issue. In the arrangement of the new cars and in the general outline, Mr. Bell has been largely guided by our American practice of which he is an enthusiastic admirer, having "done" the States from East to West and North to South. The cars are, however, built on the British system, with an independent steel underframe with side buffers, draft gear and of the road's standard.

The cars are vestibuled together and

in teak and blackwood with maroon leather upholstery. The side and end panels are filled with large views of striking Indian scenery and types of the country people. The car is illuminated by electric light and the same process operates the ceiling fans which render the interior so comfortable during the tropical heat of an Indian day.

Next to the restaurant car and vestibuled to it by vestibules of novel form designed by Mr. A. M. Bell, the carriage department superintendent, runs parlor car No. 1898, built very much on the lines of the Pullman buffet cars. It has a smoke room with observation end, furnished with easy chairs in figured brown leather, a central saloon or parlor with "armed" seats and tables, finished in polished teak and upholstered in maroon buf-

mountainous and precipitous sides of the central plateau nearly 2,000 ft. high. From Bombay (Victoria) to Karjat at the foot of the grades, the 62 miles is covered in 74 minutes, the train being hauled by one of the large new 6 coupled engines with a leading truck recently introduced by the popular locomotive superintendent, Mr. S. J. Sargant. These engines have cylinders 21x26 ins. and drivers 74 ins. diameter; the boiler carries steam at 180 lbs. per sq. in., and the fire grate has an area of 30.75 sq. ft. The weight in running approximates 224,000 lbs. with tender.

From Kayat to Lanovli, the climb is continuous, the ruling grade being 1 in 40 and up this the train is hauled by two eight coupled saddle tank locomotives with cylinders 18x26 ins. and drivers 48 ins. diam-

eter. There is a reversing station at $7\frac{1}{4}$ miles, necessitating a stop of 4 minutes, while the engines run round the train and attach at the rear to continue the journey to the summit. The time allowed on this section is 50 minutes, and the distance 17 miles.

Locomotives are again changed at

lected, and this fight with the elements caused an extra outlay to get trains over the road in the hard weather. It has since taxed the resources of the motive power and car departments to put the rolling stock in good shape again, and at the same time do the ordinary business of the summer months. In many

of its kind, has a "hump" in the center from which tracks slope in both directions. There are to be twenty-three classification tracks on the east and eighteen on the west. Cars are pushed in the desired direction over the hump and descend into the classification tracks by gravity. The main line switches and signals for this yard will be operated from a signal tower which has lately been installed. The yard will be equipped with all necessary buildings and appliances for doing work rapidly and economically.

Mortar was made by the people of Tahiti when our ancestors were shivering in holes in the rocks. They dived into the sea, brought up lumps of coral, burned them in pits, using wood as fuel, and mixed the lime they got in this fashion with sharp sand and water. With this mixture the ingenious savage plastered the walls and floors of his house, and a better mortar could not be obtained.

The Delaware & Hudson Railroad are building a car repair shop at Troy, N. Y., and work on the new plant is being rapidly pushed ahead. Part of the car repairing now done at Green Island will be done at Troy when the new shops are opened.

Savages sometimes produced ingenious inventions. One of them, which is perhaps the most familiar object of modern life, is the tobacco pipe—not only the common clay which the North American

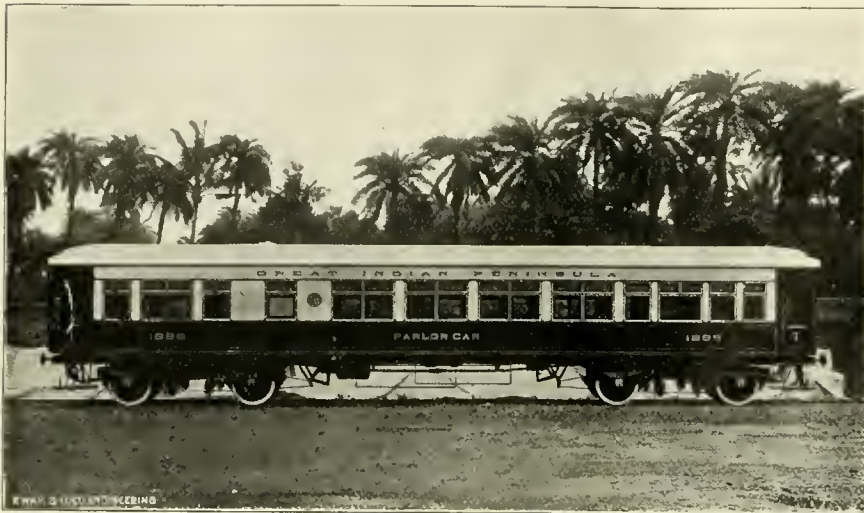

PARLOR CAR—GREAT INDIAN PENINSULA RAILWAY.

Lanovli and a four coupled bogie express backs on with cylinders 18x26 and drivers 79 ins. diameter for the finishing spin to Poona. An intermediate stop at Telegoan a mountain resort, absorbs nearly 6 minutes and spoils the through run. Considering this detention, the 51 minutes allowed from Lanovli to Poona, 40 miles, is not too much time for a run over a single track with numerous stations and passing places where line clear tablets have to be exchanged. The locomotives pick these up automatically on the fact through trains.

The energetic management of the "G. I. P." has made a decided "hit," and secured the appreciation of the traveling public in India by the introduction of these new, up to date cars. The ever increasing multitude of American tourists visiting the Orient during the cold weather of each year will be able to enjoy the comforts of their home railroading on the new vestibuled trains of India's pioneer section of her transcontinental railway system.

During the last year the cost of operating railways or as it is often called conducting transportation has risen very considerably above that of the previous years. This is not due to any increase in the volume of business done but is rather the result of the higher prices of coal and of larger expenditures for wages. Last spring the railways emerged from a particularly trying winter in which repairs in the motive power and maintenance of way departments had, generally speaking, been seriously neg-

lected, and this fight with the elements caused an extra outlay to get trains over the road in the hard weather. It has since taxed the resources of the motive power and car departments to put the rolling stock in good shape again, and at the same time do the ordinary business of the summer months. In many

The New York Central yard at De Witt, N. Y., is probably the largest of

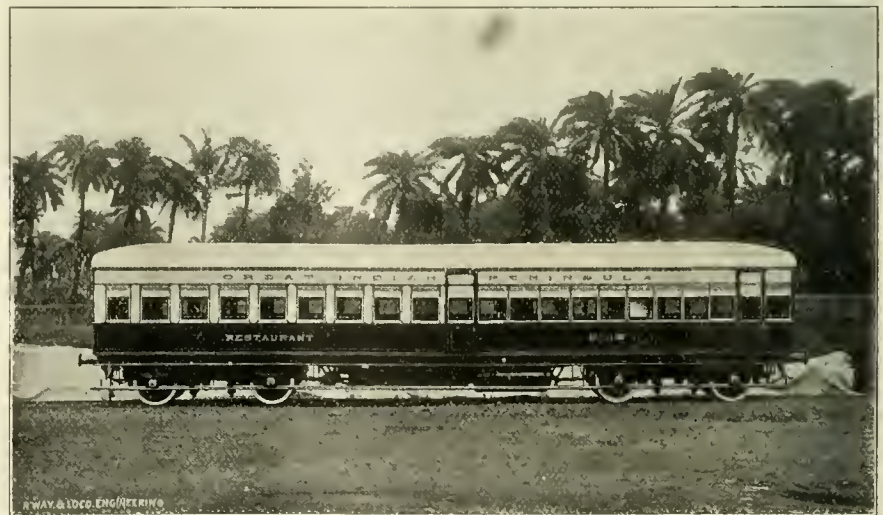

RESTAURANT CAR—GREAT INDIAN PENINSULA RAILWAY.

its kind in the world. It stretches from De Witt to beyond the village of Minoa, a distance of over four miles, and will contain about 75 miles of track. There is storage capacity for about 7,000 cars and it is expected that upwards of 4,000 cars can be handled there every day. The yard, like others

Indians moulded centuries ago out of the red sandstone of Colorado, but the wooden pipe, the prototype of the everyday briar.

It is difficulties, not facilities, that nourish bodily and mental energy.—*John Stuart Mill.*

General Correspondence.

A Letter of Appreciation and of Advice.

The following list of "Dont's" has been sent us by a traveling engineer in Mexico who says that he is living in what is supposed to be a country isolated from the rest of the world, yet he says that it does not seem so to him when RAILWAY AND LOCOMOTIVE ENGINEERING comes to hand about the 7th of each month.

He says that in that country they have to deal with a class of men or boys who come to Mexico and expect rapid promotion. Many others appear whose physical condition is such that they could not pass on most of the roads in the United States, and that too many are intemperate. The dont's are as follows:

DONT'S FOR ENGINEERS.

1. Don't hire out as an engineer and then ask us what to do.
2. Don't tell us your troubles or what you know. We know that, but get in on time.
3. Don't keep the wires hot telling your troubles to the brass founders and the management.
4. Don't do your work like a Scranton School graduate.
5. Don't do any work on the engine you are running, as she can run without it; so can your stomach.
6. Don't tell your troubles to the roundhouse foreman—he has none—but put them on the book.
7. Don't report any work; you might get into disfavor and receive no favors for not so doing.
8. Don't leave an engine in condition to go out; it might delay you next trip if you have nothing to do.
9. Don't take the pounds out of the engine, but pound the take out of her.
10. Don't miss any stitches in time, it might save nine.
11. Don't miss the miles and payday once in 30 days.
12. Don't leave terminals short on time with supplies.
13. Don't observe company rules. Rule 7, it's for you.
14. Don't forget there are other trains on the road beside the one you are pulling.
15. Don't hold the main line at meeting points because you are there first and have that right.
16. Don't assist any train over the road without orders.
17. Don't do any switching on the train ahead, it might get you over the road and save an hour's delay.

18. Don't think overtime is paid for cigarette smoking. With a little forethought you might get in on time.

19. Don't jump out and leave the company to pay your bills; they have lots of men.

20. Don't ask for credit and expect some one to foot the bills; some brother stood good for that.

21. Don't forget to tell all you know, as you are the only "windy" on the road.

F. C. I.

Hard at Work.

"A Well Kept Compound Hard at Work" is the caption under a reproduction of a photograph which was taken when the train was going at

Southern Pacific Shop Notes.

To one mechanically inclined a trip through the East Los Angeles shops of the Southern Pacific amply repays the effort. The shops are up to date, the machinery being of the latest improved motor-driven type. While all popular makes of machines are used here, the Niles-Bement-Pond tools and machines are decidedly in the majority. The placing of these machines has been so arranged as to use all available space and still allow plenty of elbow room to the operator.

On the erecting side racks are provided for all of the furnishings necessary on a locomotive. These racks oc-



A WELL KEPT COMPOUND HARD AT WORK.

a speed of about 60 miles per hour. The glass plate used in the camera was about 8x10 ins. and was coated with a very sensitive solution which is powerfully acted upon by light even with so short an exposure as the 1-150 part of a second. The sensitive chemical used on the plate has also been specially prepared and has the property of preserving the relative effects of light and shade as seen by the eye. With an ordinary plate the blue color of the sky photographs white and the effect of white steam against a blue sky is practically as if there was little or no steam coming from the engine. In our photograph the color tones of earth, sky, train and the cloud of steam above are all reproduced with marked and interesting contrast.

Rachus, W'yom.

F. JUKES.

cupy the space between the various pits, and consequently the floor is kept scrupulously clean and clear of litter. Through the center and parallel with the length of the building is the transfer track connecting with all the pits. The transfer arrangement is something new. Instead of a transfer table there is at each intersection an air jack whose top, when not in use, is level with the floor. Driving wheels, truck wheels or anything to be moved from one part of the shop to the other can be turned on these jacks to the main track or its intersections.

Convenient 4 and 5-ton self-supporting cranes operated by compressed air are liberally distributed along the entire length of the shop to facilitate the rapid handling of work.

Novo tool steel is very much in evidence here and is giving excellent results.

When completed, the new extension to the blacksmith shop will make that department one of the best arranged smithshops in the country. The ground plan shows 6 steam hammers, 3 post hammers, 12 large forge fires and 6 self-supporting, 20 ft., 5-ton cranes for heavy frame work, 18 small forge fires for the lighter work, 2 bolt-headers, 1 bull-dozer, 1 large and 3 small oil furnaces.

The large lye vat is a novelty, and here, too, may be seen one of the numerous self-supporting cranes. Everything large or small, from a driving wheel to a globe valve, receives its baptism in this vat for the removal of grease or paint before being passed on to the mechanic.

Plainly the company has realized the fact that a contented employee does the best work, and with this fact in mind they are constructing two buildings, one for the use of the men in the machine shops and one for those in the car shops. Through the center and along the inner walls of each building are well-ventilated lockers of iron grating. Each man has his key and the foreman the duplicate. Next to the lockers along the walls are the lavatories, ten groups to a side and eight basins to a group. Then nearer the middle of the buildings come the long benches and tables for the noonday meal and rest. At the end of the building are bicycle racks. In all there are 160 wash basins, 372 lockers and 372 bicycle racks in each building.

The same care that is bestowed on the shops is given also to the roundhouse. Everything is clean. The same pride that was shown in the power when it was "my engine" is now displayed by the company in the care of the company's engines. Since the pooling of the engines the company has practiced what it formerly preached, "cleanliness." Many a road could get an object lesson from the Southern Pacific in this respect.

All their engines are washed out with hot water, and, as water is one of the great items of expense, they have found a means of turning the waste water from the pits into a well and thence they elevate it by compressed air and an automatic ejector, to a tank 70 ft. above the ground. This ejector is a novelty and in its two years' use has required no repairs.

This ejector and all the other labor-saving devices in use in these shops are the offspring of the fertile brains of Alexander Campbell, draughtsman, and P. Sheedy, superintendent of motive power, both of whom are old in the Southern Pacific service.

No wonder the delegates to the Engineers' Convention looked with wistful eyes at their Los Angeles brethren with their contented, satisfied expression of countenance. This contentment among the employees is due to Mr. H. J. Small, general superintendent of motive power and machinery, who has had the foresight to surround himself with able subordinates. He has the welfare of all at heart and realizes that contentment among employees is one of the chief factors in the company's success.

JOSEPH A. BAKER.

Extracting Broken Studs.

Mr. James Kennedy (on page 471, October number) gives a good way for removing broken studs, and as I have for years been practicing a better plan, wish to present it to your readers. He says: "In the event of the stud being broken

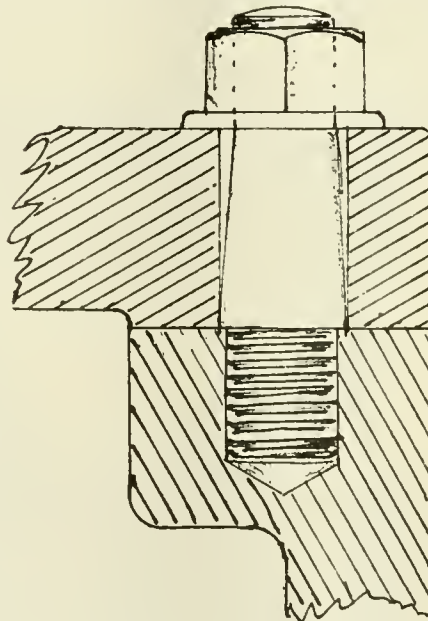

PROPOSED NEW FORM OF STUD

close to the metal into which it has been screwed." Did anyone ever see one broken anywhere else?

My remedy for the trouble is to avoid it by making all studs one size larger where they go into the casting. That is to say, a 1-in. stud is to be $1\frac{1}{8}$ ins. where it screws in and 1 in. where the nut goes on, for when such a stud is broken it will break at the bottom of the nut, and by chipping flats on the stub, the piece can be removed in as many minutes as it would take hours to drill out one of the ordinary sort. Of course, what we have now is what interests engineers, and the addition of a few dollars to a ten thousand dollar engine will probably prevent studs being made right for another generation or at least until some man like Cornelius Vanderbilt gets hold of it and relieves posterity of the present nuisance.

If master mechanics ordering engines

insisted upon the new form as shown in the cut, which form of stud I have demonstrated with 25 years' experience to be right, some of the present repair men would be likely to say something complimentary.

JOHN E. SWEET.

Ways of a Good Engineer.

For some time I have been an interested reader of your excellent magazine. I do not believe any one in railway service, no matter how efficient he may be at present, can fail to profit by a careful reading of its pages.

I have noticed in your pages much discussion in reference to running and management of the locomotive. During my service as fireman I have been both a careful reader, student and observer, and I have arrived at the conclusion that no set rule can be laid down that will suit every case and all situations. The only way that an engineer can hope to become really proficient in his work, and creditable to his vocation, is to study his machine, observe effects and study the causes that produce them.

To fire or run a locomotive properly there must be systematic work on the part of both engineer and fireman. There is but one correct method of handling a locomotive, but the advisability of using the correct method depends upon many considerations. To illustrate: We know ordinarily an engine with valves properly set should be "cut back" to cut off, say, at one-fourth of the piston stroke. But suppose we have an engine with excessive lead, or valves that are "off," then we know that the correct theoretical method of handling is the worst practically. Yet a careful man will have no trouble in finding the proper "working notch" even in these cases, and having found it, works the engine in a steady, systematic manner that enables the fireman to adapt his firing to the working of the engine.

I have worked with men who handled an engine in every conceivable manner both right and wrong, but of all the vices that I abhor in engine running is that of toying with the throttle. The man who practices it shouts his ignorance to the winds with every manipulation, puts himself on record as wasteful with his superiors, inspires every intelligent fireman with a nightmare of dread when called to work with him. The practice of continually pulling out and pushing in the throttle in ordinary working does not admit of any intelligent co-operation on the part of a fireman. The fireman can notice what is being done with the reverse lever, and can fire his engine heavy or light, as it is "hooked up" or "dropped," but the man who keeps the reverse lever five or six notches too low, and does all the rest with the throttle, goes it alone and al-

lows his assistant no choice but to cast brains aside and degenerate into a blind, unreasoning heaver of coal, for co-operation on the part of a fireman with an engineer who handles an engine in this way is out of the question.

My observation leads me to believe that in pulling an ordinary train over ordinary stretches of road a short cut-off and wide throttle should be used, but of course where the work can be done with proper cut-off and light throttle it should be done. I do not believe that in the interest of efficiency it is enough that a man know that an engine must be "hooked up." He should be required to know *why* it is done, what is accomplished by it. Unless he does, his success is accidental and hangs by a very slender thread.

Another very galling vice in engineers is that of slipping drivers unnecessarily. This practice makes many a bad trip out of what might have been a good one but for a ruined fire, for no fireman can put in a fire in such a manner as to make it "fool proof." We know that no matter how careful an engineer may be drivers will slip, but to practice slipping them is little short of crime, viewed in any light. It certainly argues grossest ignorance of the laws of adhesion for a man trying to start a train to continually slip the drivers of an engine. A schoolboy should know that adhesion practically is gone when the wheel slips, and the object therefore should be to supply steam to the cylinders sufficient to exert all the power on the piston that the adhesion of the drivers will hold without slipping. In this way the engine exerts its maximum power. The worst feature of slipping the drivers of an engine is that the more one is slipped the more it wants to slip. The tire becomes glazed and glassy, and its adhesion impaired by the practice. This is beyond dispute.

In conclusion I may say that for the man whose intentions are good, but whose skill or knowledge is deficient, I have but feelings of kindness and sympathy. But with the means of instruction and improvement now within easy reach of every ambitious man, is there any excuse? Nothing but deficiency latent in the individual himself is responsible. To be a good engineer means much. If the life of an engineer has charm for one he could not have a worthier aim than to become what is called a good engineer, and it is an end that one should be proud to attain, and for which he should be willing to consecrate his mind, and give his best thought and effort through life. For changes come so rapidly that when a man ceases to be a student and a willing and zealous learner he becomes a back number very quickly. The unambitious man in railway service is a nuisance in

whatever capacity, but the ignorant, unambitious engineer is the greatest butcher of efficiency in the entire list.

WM. WESTERFIELD.

Charleston, Ill.

Signals Showing Condition of Bridges.

While the verdict of the officials of the Denver & Rio Grande Railroad, relating to the great disaster on their road at Eden, Colorado, on the 7th of August was "unavoidable," is that really the case?

Why is it not a practical proposition to place the regular railway danger signal on all of these acknowledged danger points, and then so arrange it that the "forces" that destroy the safety of the roadbed will be made to set and display the danger signals? Is the fact understood that these "forces" that destroy the roadbed of a railroad can be made to set a signal with as great a degree of certainty as is now obtained by the use of electricity, etc., etc., to set signals?

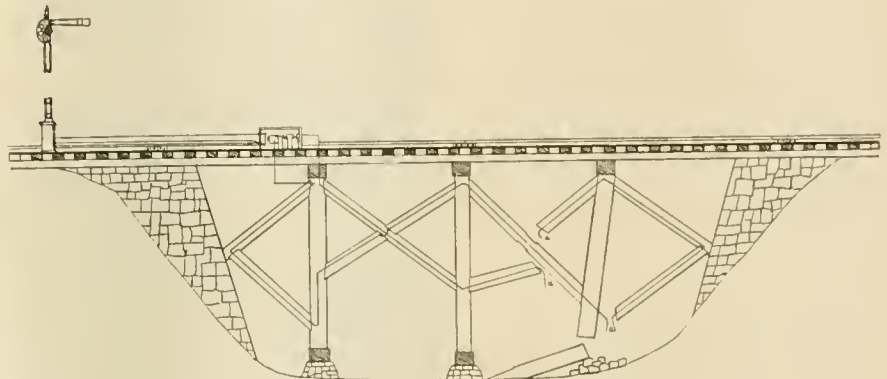

AUTOMATIC ELECTRIC BRIDGE PROTECTION.

Would not the amount of protection afforded a railway company by utilizing this "force or power" justify them in protecting these danger points with this system—virtually placing a watchman on duty, where danger lurked, without the expense attached to the regular form of watchman?

The displaying of all railroad signals at the present time is done by power controlled by the mind of man.

I affirm that signals can be displayed by the "power" that cannot be controlled by the mind of man, and this in a practical manner. CHARLES MENGES.

Los Angeles, Cal.

Behavior of Elevated Train Men.

There is at the Sullivan Square terminal of the Boston elevated railroad an instruction room fitted with the necessary electrical and air brake apparatus, and motor men, conductors, guards, etc., are given object lessons and lectures and are made to qualify by handling the apparatus and by answering questions.

There is, however, another feature in

the instruction given to the Boston elevated employees which is decidedly novel and the results of which are plainly evident to any observant person who patronizes the road. The men are instructed in manners, and are taught to behave as the company wishes their employees to behave when dealing with the traveling public. The Boston elevated railroad officials have fully realized, that because a man or woman has handed over 5 cents for his or her transportation, that fact does not entitle a paid representative of the company to rudely or offensively shout some rule at the man or woman who patronizes the road, and the company desire that their men shall so understand it.

The instruction given in the Boston school of manners for elevated trainmen is based on common sense and is regarded as an aid to the prompt and orderly transaction of the business the company is engaged in, which is the transportation of human beings. The lecturer points out to his class that nine-

tenths of the big thoughtless public are all right and mean to conform to the rules, but they may not know them or may not grasp their significance, and that many people become confused when traveling and would be thankful to be quietly set right, but who become still more confused or angry when spoken to in an insolent manner, and when thus rendered undesirably conspicuous may become stubborn and argumentative, and so delay the prompt transaction of business, which is transportation for a price paid.

The lecturer recognizes the existence of the person who is "looking for trouble" and warns his hearers that this man, is not singling an elevated trainman out for his sole attention, he is distributing trouble to all who are compelled to deal with him in any way, and the instructor advises the elevated trainmen not to get down to the trouble seeker's level by becoming angry. The trouble seeker wants to have a row, therefore don't let him have it, because that is not a legitimate demand on the time and energies

of the employees of a public service corporation. A first class trouble seeker who cannot disturb anybody is a trouble seeker pretty nearly put out of business. The men are told that "when a passenger takes your number, you know whether you've done wrong or not. If you haven't, then's the time to keep from doing wrong by holding your tongue. He likes to take your number. You know he likes to take it. We know he likes to take it. Your business is to get the train in and out of the station and to be polite while doing it."

There is one supremely simple principle which runs through this Boston elevated idea of doing business. Politeness pays because ninety-nine times out of a hundred it saves time, and by the way it is very pleasant for all concerned. The crying evil on many a road to-day, both steam and electric, is that employees who are called upon to enforce a rule forget that it is the company's rule and not their own rule, and insolently say "I will not have this," instead of "the company does not permit."

This Boston company have taken the trouble to teach their men manners, and the good results are apparent, for the old adage still holds true, "like master, like man." In thus instructing their employees and in strictly maintaining discipline, they have managed to secure the services of "elevated" trainmen in more senses than one. H.

Care of Reverse Lever.

The condition of the reverse lever is usually a fair sample of the general condition of the engine, for it is, as a rule, safe to assume that the man who can sit contentedly beside a rattling pounding reverse lever without making the trifling effort usually necessary to correct the evil, is not likely to be worried much by knocking rods or pounding boxes, or a hard riding engine, that call for some labor as well as skill to apply the remedy. To the lack of care as to adjustment may be added the neglect of oiling reach rod and lever connections, which naturally follows, not only causing excessive wear of same, but for the reason that the lever fails to hold the links firmly in the position for which it is set, hastens the wear of nearly every connection of the valve gear to such an extent as to require refitting of those parts long before it should be necessary.

T. P. WHELAN.

The Pullman Palace Car Company follow a very uniform policy in their dealings with States that assess for taxation the company's property. Their able lawyers always enter protests against the assessments being excessive and in many cases succeed in having reductions made.

Signals and Signaling.

BY GEORGE SHERWOOD HODGINS.

(Continued from page 456)

THE TRAIN STAFF SYSTEM.

There is probably no system of train operation, adapted to single track roads, which is so completely safe as that known as the train staff system. This system, when properly worked, not only becomes an absolute block signal arrangement, but it becomes also the train dispatcher for the time being, and it eliminates all forgetfulness, all chance of misunderstanding and all hasty and confused action on the part of trainmen and operator.

The system is, briefly, that each block is supplied with two train staff instruments, one placed at the entrance of the block and the other at the leav-

rights, may be briefly stated as follows: Train No. 1, southbound, at the entrance to block *A*, desires to proceed to block *B*, and in order to do so under this system, the engineer of the train must have in his possession a train staff from the instrument at *A*. In order to get this staff, the operator, by means of an electric bell system and a signal code, asks the operator at *B* to unlock the train staff instrument at *A*. If there be no train in the block between *A* and *B*, the operator at *B*, in the ordinary course of events, complies with the request by pressing an electric button in tower *B*, which unlocks the instrument at *A*, and at the same time he completely prevents *A* from unlocking the instrument at *B*. The operator at *A* is thus enabled to withdraw only one train staff from his instrument, which, when given to those in charge of train No. 1, constitutes their undisputed right to proceed south. While this staff is out of the instrument at *A*, it is absolutely impossible for either operator to effect the withdrawal of a second staff. A second staff may be asked for, it is true, but an effort to comply with such a request would prove abortive, for so long as there is one staff out in the block no other staff can be removed from the instruments at either end. In this way trains making opposing movements cannot possibly be in the block at the same time and no train can follow southbound No. 1 until it has arrived at *B* and the staff has been placed in the instrument at *B*.

One may liken the train staff to a ferryboat crossing a river, for it there be but one boat, it is obvious that as soon as she has left one wharf, all movement of people or freight other than those which she carries must be suspended until her arrival at the other side. The train staff system, while it is as absolute in safety as regards collisions as is the single ferryboat on a river, yet possesses more flexibility, if one may say so, than the single ferry system could possibly possess.

If after the staff for train No. 1, southbound, had been correctly withdrawn from the instrument at *A* and before train No. 1 had started, it was found that it would be more desirable to move train No. 2, northbound, through the block, the operator at *B* could, by means of telephone or telegraph, so inform the operator at *A* of the new arrangement, giving authority from the train dispatcher. On any well-regulated railroad *A* would have no option but to comply with this order, but it would be necessary for him to first secure possession of the staff from those in charge of train No. 1, and return it safely to his own instru-

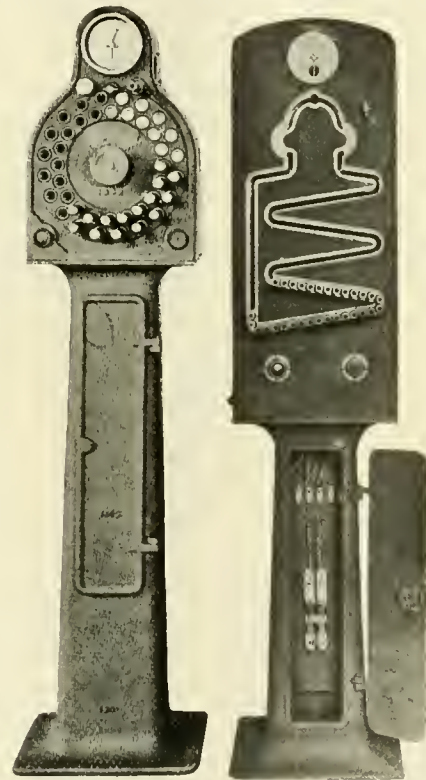

ORIGINAL STAFF MACHINE.

LATEST FORM OF STAFF MACHINE.

ing end. These instruments contain each a certain number of what are called train staffs. The handles of these staffs project from the instrument, but an electrically controlled lock prevents the removal of any of them from either instrument, and it is only by the performance of certain predetermined acts by one operator, with the full knowledge and consent of the other, that a staff can be withdrawn from one of the instruments.

The staff, when in possession of a locomotive engineer, constitutes his right to proceed, and the method of obtaining this right, which at the same time effectually bars out all other train

ment, and it would then only become possible for him to unlock *B*'s instrument for the withdrawal of a staff at *B* for train No. 2, northbound. Thus it is evident that two train staffs cannot be out at the same time.

If, however, it became necessary to allow train No. 3, southbound, to follow train No. 1, the same procedure would be followed. The staff carried by No. 1 from *A* would have to be actually placed in the instrument at *B* before the operator at *B* could again electrically unlock the instrument at *A* for the correct withdrawal of a second staff at *A*.

The continuous movement of traffic in one direction for a certain number of hours might exhaust the number of staffs contained in, say, the instrument at *A*, and the method employed would then be for the operator at *A*, when his instrument was becoming depleted, to apply to some designated person, supplied by the company with a key capable of opening both instruments, and request him to open the instrument at *B*, and bring back the requisite number of staffs to *A*, which, when entered in the receiving instrument, at once become locked in, and capable of withdrawal only by the authorized method.

We have thus far considered the train staff system without reference to the signals displayed at either end of the block, but there are further modifications of this system which increase its value as a safety appliance. The train staff as made by the Union Switch & Signal Company, of Swissvale, Pa., may, when desired, be used as a key by which permission to proceed is not only absolutely secured, but the right to do so may be indicated by signal as well. As soon as the operator at *A* has legitimately withdrawn the staff for train No. 1, southbound, and before he has delivered it into the custody of those in charge of that train he is compelled on some roads to use it as a key by which only he can unlock the home signal governing all southbound movement entering the block, and having thus cleared his stop signal, he gives the staff to those in charge of the train. The possession of the staff by the crew of train No. 1, gives them the right to proceed south, and the operator having cleared his stop signal, lets the train go. The lowering of the stop signal at *A* has, however, broken all electrical connection between himself and the operator at *B*, and after the train has left, he is unable to ask for or receive an "unlock," and has in the language of the day put his station "out of business," and it remains out of business until he puts the protecting signal to the stop position behind the train which he has thus authorized to proceed. A slotted

signal may be used which automatically returns to the stop position after the train has passed it.

The Union Switch & Signal Company's train staff instrument has a small indicating dial on top, and this is made to indicate on both instruments whether all the staffs are in, though distributed between the two instruments, or if a staff is out of instrument *A* or out of instrument *B*. The actual state of the case is therefore apparent in either tower at any time to anyone who examines one of the indicating dials. The safety feature of whole arrangement, however, lies in the fact that whether the indication given by the pointer on the dials be observed or not, the existing state of affairs would at once become apparent, if any endeavor was made to withdraw a staff from either instrument. The operators at *A* and *B* cannot simultaneously withdraw staffs



AUTOMATIC SIGNALS, LOWER AND SHORTER ARMS INDICATING THE DIVERGING ROUTE.

from their instruments, for the "unlock" given by *B* to *A* has most securely maintained the lock-up condition of *B*'s instrument and at the same time it prevents *A* from unlocking *B*'s instrument even if he had been requested to do so.

On some roads a still further precautionary measure is in vogue. On these roads the train staff is made in two equal parts, which screw together in the middle. It may be well to here remark that the train staff is really a key which is capable of being securely imprisoned in the staff instruments, and also of being used for releasing the signal lever lock at either end of the block. The two-part train staff therefore consists of what may be called a handle and a key. The key-end, when unscrewed from the handle, is of such a length that if pushed into the machine by itself, and when locked in, it practically disappears and cannot again be manipulated by the operator,

the presence of the handle being necessary to its further use.

The advantage of the two-part staff is that the handle-end can be given to the men on the engine and the key-end can be placed in charge of the conductor. It is obvious that when this is done if a break-in-two occurred in the block and the engine and some cars arrived at *B*, the handle-end would be useless in the train staff instrument and useless for unlocking signals and the actual clearing of the block by the arrival of the rear portion of the train with the conductor and the key-end of the staff would be essential for the subsequent movement of traffic in either direction.

The train staff system has been most successfully worked out, and safety, like the diapason in a church organ, is the fundamental stop to which the treble of rapid passenger train operation and the bass of slower freight movement have been tuned, and no note of discord can possibly mar the harmony of the whole.

The train staff instrument as at present made by the Union Switch & Signal Company has been recently very much simplified. The details have been modified and the new design has been patented by Mr. T. H. Patenall, an engineer of that company. The original staff instrument had separate holes for each staff, and each staff had a separate, though interdependent, locking mechanism. The new train staff instrument, while similar in general outline to the first one, has only one hole for entering or withdrawing a staff, and a zig-zag slot. It is so designed that when a staff is entered it passes but one lock, which may be called the neck of the bottle, and having once passed the locking point no reverse motion is possible, and the staff is held in the slot with the handle projecting by means of a shoulder which bears against the inner edges of the slot, which is narrowed from the entering point downward. The unlocking point is at the entering hole and cannot be passed by any staff until the electrical "unlock" has been asked for and received in the regular way. The new instrument compels the use of the staffs in rotation and thus distributes the wear equally among them all. There is, therefore, only one lock in the new machine, situated at the entrance and withdrawal hole, instead of an electrically operated lock for each individual staff.

The improvement here described is not only a more satisfactory design from a mechanical and electrical point of view, but it possesses the additional advantage of reduced cost of construction and maintenance without sacrificing any of the good features of the former design. This cost reduction is a feature which cannot fail to

appeal most strongly to railroad companies who are on the lookout for a most efficient and easily worked safety appliance for use on single track roads, where the possibilities of human failure must always be a silent though ever present source of serious anxiety.

The train staff in possession of a train crew is like the scepter of a king. It guarantees the absolute and authoritative right of way through the block over which it rules, and like the scepter in the hands of a monarch of old, none may even approach, until by the scepter the indication of the royal will has been made clear. No one may question, and none dare disobey. The simile is not forced, for the complete sovereignty of a train given right of way under this system remains unchallenged during its passage through the block for which it holds the staff, and by no combination of human forgetfulness, hasty action or misunderstanding can the lives of those who trust themselves to a properly operated train staff system be even momentarily jeopardized.

(To be continued.)

An amusing story was told not long ago of a freight brakeman who set out one bitterly cold night last February to flag the "flyer" which was following. He was exposed to the bleak winds of the Alleghany mountains for about an hour and a quarter, but he stopped the flyer all right. When he returned to his own train he was pretty badly frost bitten and his feet were in such a condition that his boots could not be pulled off by any ordinary means. The brakeman contended that the boots were entirely too high priced to be cut off and ruined and his friends were for some time at a loss what to do. At last it occurred to some bright individual that if the tractive effort of the locomotive could be applied to the high priced boots on the frozen feet something would have to give. The brakeman was taken out and coupled up to the locomotive by wedging the heels of the boots between the slats of the pilot. The train crew held the brakeman at an angle of 45° and the engineer cautiously backed away. There was a confused stumbling along the track for a few moments by the men when something let go and the crew found they were holding a half frozen and semi-recumbent man in their arms while the engine backed proudly away with a pair of high priced boots stuck in the pilot slats.

The sublime and the ridiculous are often so nearly related that it is difficult to class them separately. One step above the sublime makes the ridiculous, and one step above the ridiculous makes the sublime.—Paine.

Handy Shop Tools.

Fig. 1 in the illustration shows an expanding and beading tool used on the Erie. It is made up of eight parts and when applied to the tube expands and beads it with one application.

Fig. 2 shows a staybolt wrench for staybolts without the squared head. This tool is 3 ins. in diameter across the face and 1¼ ins. thick. There are three disks, of which the top one is part of the body of the tool itself, the middle one revolves in roller bearings and the bottom one is rigid, being secured to the body by two screws. It will be noted that these disks are similar to an eccentric, and the illustration shows the tool in the act of grasping a staybolt. It can

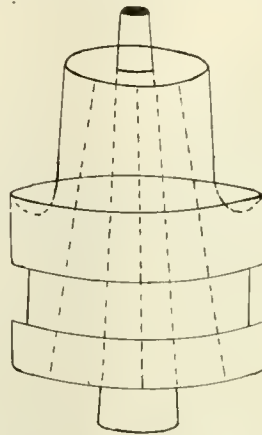

FIG. 1.—EXPANDING AND BEADING TOOL.—ERIE.

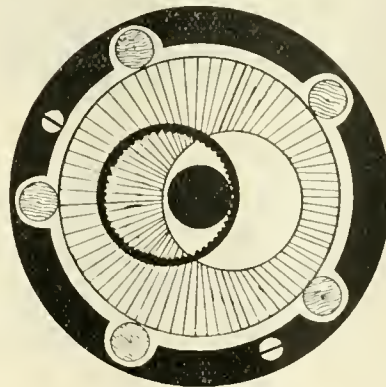

FIG. 2.—STUD EXTRACTOR.—L.V.R.R.

be attached to any motor, saves the expense of squaring the head and the consequent waste of material. It is one of the Lehigh Valley shop productions. Another handy little device that may be seen on the Lehigh is a speed recorder for measuring the feet of work a tool accomplishes in a given time. They take an ordinary McConnell adometer and to its stem secure a metal disk, the diameter of which measures 1¾ ins. This gives a circumference of 6 ins. If at any time they wish to know the exact speed the tool is cutting at, the disk is placed against the work, and as each revolution of the disk represents 6 ins., it will be found that, if correctly timed, each ½

minute registers the exact number of feet per minute the machine is speeded at.

Still another good thing on the Lehigh was the appliance used for revolving driving wheels when setting valves. Instead of making an elaborate tool they simply take the gearing from a cylinder boring bar. There is nothing now required excepting a sleeve to secure the gearing to the revolving rod under the driver, and an Imperial drill motor does the rest.

On their little shunting engine which they call the "Puff," they have an automatic uncoupling device which is operated from the engine cab and saves the switchman much leg work. A small air cylinder about the size of a brass torch is screwed to the running board. In this cylinder is a plunger which operates a rod that connects with the draw bar attachment, and if it is desired to cut the engine loose from the train the engineer opens the air valve, thereby forcing the plunger to the other end of the cylinder. This causes the rod to raise the lock and the knuckle is forced open. It has been found a great convenience and time saver to the yard brakeman who otherwise has to take many steps to the engine to uncouple her and then as many back again to some other track.

Some very live topics were discussed by the International Railway Boilermakers' Association at its last annual convention. Among the papers read were: Leaky Flues and Cracked Side Sheets; Some Points on the Care of the Modern Locomotive Boiler; Is It Necessary to Have so Many Flues in Our Locomotive Boilers, and on Copper Ferrules? An interesting discussion followed each of these papers. Some of the other papers dealt with method of staying the various parts of boilers; why direct stays leak in horizontal tubular boilers; steam boilers vs. feed-water heating and purification, and why not have a standard size fire door in locomotives.

The Atlantic Coast Line Railroad are building a large machine shop, 100x214 ft., at Rocky Mount, N. C. It is a brick structure, and when it is completed the capacity of the shops at that point will be practically doubled. The building of a large foundry is also contemplated, and when these improvements have been made there will be a very substantial increase in the company's payrolls, a condition which the townspeople regard with much satisfaction.

The imputation of inconsistency is one to which sound politicians and every honest thinker must sooner or later subject himself. The foolish and the dead alone never change their opinion.—Abraham Lincoln.

Fast Freight Engine for the Lehigh Valley.

The Baldwin Locomotive Works have recently completed for the Lehigh Valley Railroad an order for some fast freight ten-wheel engines, one of which appears in our illustration.

The cylinders are 21x28 ins. and the driving wheels measure 68½ ins. in diameter. The valve is an ordinary D-slide, balanced, and the rocker arm operates the valve rod by means of a crosshead arrangement. All the wheels under this engine are flanged, the rigid wheel base being 13 ft. 4 ins. The spring gear is arranged with overhung springs on the leading pair of drivers and springs between the upper and lower frame bars connected by driving box equalizers. There are eight driving springs in all, the rear pair being behind the trailing driver. The main drivers are the center pair, and as

The tender is of the ordinary U-shape and has a water capacity of 7,500 gallons. The weight of engine and tender in working order is 333,000 lbs., the engine itself weighing 183,000 lbs. A few of the principal dimensions are as follows:

Boiler—Dia. 69½ ins.; thickness of sheets, 1¼ in.; working pressure, 205 lbs.; staying, radial.
 Fire Box—Depth, front, 63½ ins.; back, 50½ ins.; thickness of sheets, sides, ¾ in.; back, ¾ in.; crown, ¾ in.; tube, ½ in.; water space, front, 5 ins.; sides, 3½ ins.; back, 3 ½ ins.
 Driving Journals—Main, 10x12 ins.; others, 9½x12 ins.
 Engine Truck Wheels—Journals, 5½x10½ ins.
 Wheel Base—Total engine 25 ft. 4 ins.; total engine and tender, 57 ft. 7 ins.
 Weight—On driving wheels, 144,000 lbs.; on truck front, 39,000 lbs.

The Interstate Commerce Commission's Report.

The recent report of the Interstate Commerce Commission relating to ac-

us to do is not to find fault with the report or with the Interstate Commerce Commission. Our clear duty is for every single employee in this great country to set it before him to always take the safe course in all railway operation in which he is concerned and to discourage by word and deed all recklessness or that which tends in any to weaken railroad discipline. The matter is entirely too serious to be set aside lightly, and proving that the average length of travel per head is longer here, and for less money than it is in other countries does not answer the question, nor does it bring back the dead to life. Eternal vigilance is the price of safety.

The Brotherhood of Locomotive Engineers is in a highly prosperous condition and new divisions are steadily formed. The latest on the list is Divi-



TEN-WHEEL ENGINE FOR THE LEHIGH VALLEY RAILROAD.

A. E. Mitchell, Supt. of Motive Power

Baldwin Locomotive Works, Builder

the eccentrics are on the main driving axle, the transmission bar passes over the leading axle in the form of an inverted Ω and the open ends are bolted together with a spacer below the axle.

The boiler is a straight top one with wide fire box and grates suitable for burning anthracite pea coal or finer fuel. The box is 102 ins. wide and 120¼ ins. long. This gives a grate area of 85 sq. ft. It is a fire box something after the Zera Colburn type and differs from the Wootten fire box in that it, the Colburn box, had no combustion chamber. The heating surface in this box is 198 sq. ft., which, when added to that of the flues, 3,084 sq. ft., gives a total of 3,282 sq. ft. The flues are 378 in number and are 15 ft. 8 ins. long. The Vaucrain triangular welt is used on the horizontal seams and as a stiffening piece for the dome.

idents on the railways of the United States does not make pleasant reading. Last year 9,984 persons lost their lives in railway wrecks and 78,247 were injured. In these totals employees are largely in the majority. The commissioners compare English with American railway operation, much to the advantage of the former. They say, "We have received reports from England which are as remarkable as the killings here. Approximately, the English average less than fifty thousand miles of track to our two hundred thousand, yet they do a greater per mile business than we do, they haul more passengers than we do, yet not one passenger was killed there last year."

Truth and candor may not always be pleasant, but in matters like this, they are certainly wholesome. The way for

Division No. 659, lately formed in Buffalo, N. Y. It will be composed of Pennsylvania Railroad engineers and starts with a membership of about thirty, many of whom have been members of Division No. 15. George Howell, chief engineer of Division No. 15, assisted by J. H. Horner, inspector in the Bureau of Building, formed the new lodge. The officers of the division are: Frank Goodenough, engineer; Joseph Parker, first engineer; Frank Ramsburg, second engineer; George Pfeiffer, first assistant engineer; Frank Watkins, second assistant engineer; Frank Kuhn, third assistant engineer; R. Chadwick, guide, and John C. Reese, chaplain.

The true worth of man is to be measured by the objects he pursues—*Marcus Aurelius.*

Railway and Locomotive Engineering

A Practical Journal of Railway Motive Power and Rolling Stock.

Published Monthly by
ANGUS SINCLAIR CO.,
136 Liberty Street, New York.

Telephone, 984 Cortlandt.
Cable Address, "Loceng," N. Y.
Glasgow, "Locanto."

Business Department:

ANGUS SINCLAIR, President.
FRED M. NELLIS, Vice-President.
JAMES R. PATERSON, Sec'y and Treas.

Editorial Department:

ANGUS SINCLAIR, Editor.
F. M. NELLIS,
GEO. S. HODGINS, } Associate Editors.
JOS. A. BAKER,

Advertising Department:

Eastern Representative, S. I. CARPENTER, 170 Summer St., Boston, Masa.

Western Representatives:

JOS. A. BAKER and F. B. LAWSON, 1204 Monadnock Block, Chicago, Ill.

British Representative:

THE LOCOMOTIVE PUBLISHING CO., Ltd., Amen Corner, Paternoster Row, E. C., London.

Glasgow Representative:

A. F. SINCLAIR, 15 Manor Road, Bellahouston, Glasgow.

South African Representative:

E. MILLS, P.O. Box 1477, Cape Town, S.A.

SUBSCRIPTION PRICE.

\$2.00 per year, \$1.00 for six months, postage paid to the United States, Canada and Mexico. For other parts of the world, \$2.50 or ten shillings. Single copies, 20 cents. Remit by Express Money Order, Draft, Post Office Order or Registered Letter. Mailing address can be changed as often as necessary—always give old and new address, and if you subscribed in a club, state who got it up. Please give prompt notice when your paper fails to reach you properly.

Entered at Post Office, New York, as Second-class mail matter.

Copyright by Angus Sinclair Co., 1904.

For Sale by Newdealers Everywhere.

Modern Methods of Steel Making.

An educational advantage which the members of railway clubs derive from the mixed membership, is the contribution of scientific papers from specialists outside of railway service. The information conveyed in such papers is frequently very valuable to railway men as directly bearing upon their business, although railway employees rarely have the training or opportunity to acquire the knowledge on which such papers are founded.

The latest example of this kind of paper, which has come to our notice, lately, is one on Steel Castings, presented to the Pittsburgh Railway Club by Mr. W. A. Herron, president of the Duquesne Steel Foundry Co. A question frequently sent to us by correspondents is, "What is the difference between cast steel that tools are made from, and cast steel used for making wheels?" Knowledge even of common processes spreads very slowly, for we find that the majority of reading mechanics and engineers labor under the impression that all cast steel is made by the old process discovered by Benjamin Hunts-

man, an Englishman, born 200 years ago. Steel was made long before Huntsman's time, but it was produced by what is known as the cementation process, in which a good quality of iron was intensely heated in a bed of charcoal until it absorbed the necessary quantity of carbon to convert it into steel. This was known as blistered steel from the appearance of the bars so converted. It was the only quality of steel used in Christendom, until Huntsman discovered that a highly superior article could be produced by cutting up the blistered steel and melting the mass in a crucible. The ancient Hindoos were celebrated for the production of a very fine quality of steel called wootz, which was made in very small pieces by a melting process. It had, however, no influence on the improvements of steel making that have done so much to promote the material interests of the industrial world.

Mr. Herron tells that, in modern steel making, there are three processes: the crucible, the Bessemer and the open hearth. In the crucible process, the metal is melted in pots or crucibles made of fire clay or plumbago and holding one hundred pounds or less. These pots are placed in melting holes on chambers about three feet deep and two feet square, lined with fire brick. The tops of the chambers are about level with the floor of the casting room and they are covered with iron lids, also lined with fire brick. Several of these chambers are placed in line, each communicating by means of a flue with a single stack which serves them all. Various mixtures are used in the crucibles to produce steels of the required qualities. For highest grades, blister steel, or steel made of Swedish iron bars heated to redness in a bed of charcoal, is melted in the crucible; or Swedish iron bars may be melted and brought to the required temper by putting charcoal in the pot; or blister steel may be melted with mild steel scrap; or broken pig iron of pure quality may be melted with Swedish iron. The latter is the usual practice in the foundry. Little Swedish iron is now used in this country in the manufacture of crucible steel, a pure wrought iron of domestic make being substituted.

The Bessemer process, famous for having effected a revolution in steel making, consists of blowing air through molten iron for the purpose of oxidizing or driving out the impurities or superfluous elements of carbon, silicon and manganese. When this has been done ferro manganese or spiegeleisen compounds, rich in carbon and manganese, are added in the proportions that are required to convert the charge of iron into steel. Bessemer steel besides iron contains about .15 to .2 of 1 per cent. of carbon, about 1.15 of 1 per cent. of man-

ganese, and a small quantity of silicon, all of which are desirable elements, but it also contains impurities in the form of sulphur, phosphorus and other undesirable elements.

The usual process of making Bessemer steel is to charge the converter with a mixture of pig iron and scrap which has been melted in a cupola, or blast furnace, and blow air through it until all the foreign elements that can be oxidized are discharged. The converter is a huge pear shaped vessel holding about 10 tons of metal hung on trunnions one of which is hollow providing a passage through which the air is blown. It is lined with some highly refractory substance such as ganister or fire brick and is open only at the top or small end through which the gases are forced through tuyeres in the bottom which keep the molten metal floating upon a bed of air. The condition of the charge is judged by the color of the flame passing from the mouth of the converter. When the flame drops, the carbon, silicon and manganese have been burned out. A charge of ferro-manganese or spiegeleisen is then added for the same purpose as it is put into the crucible in the crucible process. The charge is then ready for pouring into the molds which is done by tipping the converter by hydraulic machinery.

The Bessemer process is little used for making castings, the open hearth process producing a steel better adapted for castings. A modified form of Bessemer process such as the Tropenas is sometimes used. The Tropenas is a small converter with a capacity of about two tons.

The greater part of the steel castings used by railroad companies are made by the acid open hearth process in which pig iron and steel scrap is melted on the bottom or hearth of the furnace without contact with any solid fuel. The hearth is covered with very pure silica sand. Underneath the furnace proper are four large chambers, two at either end, called regenerators, which are filled with fire brick laid loosely in rows with an air space between each two rows, and each course is laid at right angles to the course below, forming checkerwork. Two of these regenerators, one at either end of the furnace, are for air and the other two for gas. The usual fuel is producer gas, but natural gas is also used. When producer gas is used the gas passes through a pipe, or flue, from the producers to the bottom of the gas regenerator at one end of the furnace and up through the checkerwork, through ports, into the furnace, where it mingles with the air coming up through the air regenerator, and combustion then takes place. The products of this combustion pass out of the furnace through the ports at the other end, into the regenerators and thence to the furnace stack.

The checkerwork is thus heated to a great heat and it in turn heats the air and gas as they enter the furnace when the flow is reversed, as it is every fifteen or twenty minutes. When natural gas is used it enters at the ends of the furnace proper, where it mingles with the heated air coming through the ports, and all four regenerators are used for air. By this method sufficient heat is generated to oxidize the silicon, manganese and carbon, and when that has been effected Ferro-silicon and Ferro-manganese are added. Pig iron is sometimes added to increase the carbon, or ore to reduce it, as the tests may show to be necessary.

In all of these processes the phosphorus and sulphur are not affected, and the materials used should contain somewhat less of these elements than is desired in the steel.

The regeneration furnace mentioned above was invented by Sir William Siemens for the purpose of conserving the heat passing out of the furnace in the shape of fuel gases and represents a very wide grasping invention. When Siemens applied to the German government for a patent on his invention, it was refused on the ridiculous ground that in the Middle Ages stones were heated and thrown into cellars of town halls to warm them. Hence these patent official lunkheads held that the principal of utilizing heat stored in bricks was old.

There is another method of steel making known as the Basic Open Hearth Process in which the phosphorus and sulphur present in the iron charge is eliminated or trapped out. This process was originally worked out by Thomas and Gilchrist, two Scotch metallurgical chemists. A very striking description of the process is given in one of Andrew Carnegie's books. It reads: "In making steel ten tons of molten pig iron is run into a big pot called a converter, and hundreds of jets of air are blown up through the mass to burn out the silicon and carbon and finally to make it steel. Now, phosphorus has a greater affinity for lime than for iron when it reaches a certain temperature, and when the air blast brings the mass to the required heat, the million particles of phosphorus, like as many ants disturbed, run hither and thither quite ready to leave the iron for the time. These clever young men (Thomas and Gilchrist) first put a lot of lime in the bottom of the pot as a bait, and into this fly the ants, perfectly delighted with their new home. The lime and slag float to the top and are drawn off—but, mark you, let the temperature fall and the new home get too cold to suit these Salamanders, back into the steel they go, although the temperature may be over 2,000 degrees, hot enough to melt a bar of steel in a moment if

thrown into the pot. No, they must have 2,500 degrees in the lime or they will rush back to the metal.

"But now comes a difficulty; 2,500 degrees is so very hot that no ordinary pot burning will stand it; of course the iron pot itself will not last a moment. If ganister or fire brick is used, it just crumbles away and besides then the plaguey particles of phosphorus will rush into it and tear it all to pieces. The great point is to get a basic lining that is one free from silica. This has at last been accomplished, and now the basic process is destined to revolutionize the manufacture of steel, for out of the poorest ones, steel or iron much poorer than any now made for rails or bridges can be obtained."

The lining material which proved a success was dolomite an intensely refractory compound of lime and magnesia. In the basic process of steel making this material is successfully employed for making the bottom of the furnace and the sides above the level reached by the molten metal. Magnesite, a magnesium carbonate, is sometimes used. The lining made from both these compounds has more affinity for phosphorus, that bane of steel, than iron and on that account the basic produces a very pure steel.

Basic steel is not so liquid as acid steel which detracts from its usefulness for some purposes.

We recommend our readers to obtain from the secretary of the Pittsburgh Railway Club a copy of the paper from which most of the foregoing facts have been gathered. They will find it well worthy of careful study.

Increase the Interest in Brotherhood Meetings.

Most of the railway clubs scattered throughout this continent have their doors of admission open enough to take in practically all railway men, and there are many workers in the operating force who are members; but their voices are too seldom heard. Men who are actively engaged in train, signal and road service could often give valuable information to the managing classes if they were encouraged to do so.

In this connection a valuable suggestion was made by Mr. James Osborne, general superintendent East Div. Canadian Pacific Railway, to a meeting of the Brotherhood of Locomotive Engineers at the time they held their Union meeting in Montreal. Taking up the question of train men making themselves prepared to pass the examinations now exacted by railway companies, he proposed that brotherhood meetings should consider and discuss the various subjects that were of value and interest to them as railway men.

From our experience of brotherhood meetings, we are aware that difficulty is frequently experienced in bringing out the members for the reason that the meetings are not made interesting or attractive. We would suggest that the trainmen take up the code of questions that many companies are now providing as a basis of examination for promotion. It is easy enough acquiring in a routine fashion the answers that will enable a candidate to pass these examinations, but at the same time the man might be deficient in real knowledge of the subjects. If lodges generally would take up the code of questions and thoroughly discuss the meaning and intention of each they would widen the knowledge of the members and increase their value as trainmen. A course of that character would be of the greatest value to the members and would make the meetings so attractive that complaints about absentees would no longer be heard.

There are many other lines of investigation which trainmen could profitably take up. The understanding of train rules is not universally so clear that they could not be discussed with profitable interest. Ambiguous train orders and specimens of illegible handwriting would provide matter for interchange of thought which would be more than a pastime. The question box, which has proved so good for some clubs, might be called into use generally by brotherhood men, who in fact originated that practical way of getting puzzling questions answered, but have ignored it lately. When people display a disposition to find interest in discussing things relating to their daily work there is no need of seasonable themes.

Overtime in Train Operation.

The most prolific causes of overtime in train operation outside unexpected mishaps, is terminal detention, meeting trains and local work. Thus in effect spoke Mr. F. W. Quimby, trainmaster on the C. I. & L. Ry. at the annual meeting of the Central Association of Railroad Officers.

Terminal yards on many roads are simply groups of tracks of irregular lengths laid from time to time to increase facilities, but the net result of these irregularly constructed yards is congested traffic and slow movement in making up trains. A yard planned in two sections and intended to deal with trains moving in opposite directions would do away with overtime for train crews before starting out and at the end of a trip, which costs money.

On single track roads where traffic has steadily increased conditions difficult to deal with arise and even with good dispatching delays to inferior trains out of all proportion to what is

expected, take place. Train detention on sidings, waiting for superior trains, often amounts to 35 per cent. of the total time on the road, the consequent overtime money paid to the crews ready to move but standing still may well form a subject for the consideration of the directors, who would do well to weigh the interest on the outlay for the remedy as against the steady cash payments for overtime the year round.

Where single track conditions cannot be altered the situation may be relieved by a certain reduction of the tonnage hauled, which permits quicker movement and less fuel burned and fewer hours of overtime to be paid for. To economically handle freight it must be kept moving; unprofitable expense begins the moment it comes to a halt on a siding. Train crews are no more anxious to make overtime than the company is willing to pay for it.

Local trains, handling way freight and constantly doing switching is a source of overtime hard to deal with, as the business fluctuates from day to day. It has, however, been found advantageous, on a long local run where business is heavy to drop the work at some convenient station, at night, and have the local train make a straight run from that point to the terminal. This reduces the overtime of that crew. Where there is heavy way freight business all the time, it has been found that to run two switching trains from each terminal to a central point and return will greatly reduce, if not entirely do away with, local train overtime. It is cheaper to hold a few operators on overtime pay so as to enable the dispatcher to move delayed trains than to pay overtime to perhaps six men lying in a siding and who are entitled to higher pay than the operators. The whole question is capable of statement in very short terms, excessive overtime breeds disaster, and such overtime is thoroughly unprofitable.

Power of Organization.

The training that might best prepare a man to become successful at the head of a railroad mechanical department was for long years a matter of experiment, and there still continues to be diversity of opinion about the practical education likely to produce the most satisfactory results. The early practice was to select foremen from the most expert mechanics in shops; the foremen became master mechanics and the heads of their departments. This was varied slightly by putting locomotive engineers in the line of promotion, and they frequently reached the top. The men raised by that method of selection performed their duties as successfully as any other railway officials, their marked strength or weakness depending to a great extent

upon the personal equation. A few years ago a demand arose for college graduates to enter upon the line of service that would land them expeditiously in the chair of the superintendent of motive power. Perhaps too much was expected of these men, and that they proved less efficient than their friends anticipated. At any rate they are no longer conspicuously in demand. The present tendency is to look for men with sound practical training combined with some technical knowledge as candidates for prominent mechanical positions.

The writer has frequently heard railroad managers express themselves as badly disappointed with mechanical men who come to them with the highest recommendations. In the course of talk the listener would learn that the recommendations had been given for the person's mechanical ability as a mechanical engineer or as a strenuous individual, likely to push business. Only a few railway managers have come to realize that ability as a mechanical engineer or personal energy are of small importance in a superintendent of motive power, compared with capacity for business management. A good business man will make more of a success at the head of the department than a first class mechanic or engineer, unless the mechanical training is combined with sound executive ability. The best shop foreman we have ever met was not a mechanic at all. He learned his business through being shop timekeeper, and learned it well. The experience as timekeeper gave him the information of what different men could and would do; and habits of observation informed him how men could be managed in a way that kept them happy and contented while giving their employer a fair equivalent in work for the wages paid them. Apart from the ability for organization which all persons in charge of departments must have to be successful, the intimate knowledge of men and their ways is of the greatest importance.

In a paper presented to the North-Western Railway Club by Mr. L. A. Larson on Systematic Methods in Mechanical Departments, there are many highly sensible ideas that deserve the attention of all concerned. The pith of the subject is given in the following sentences:

"The superintendent motive power, more than any other railway official, because of the entrance at every point of diverse personal elements, finds himself facing this problem of effective organization. His success or failure will be foreshadowed by the methods he adopts. A systematic control of details does not necessarily imply a personal acquaintance extending to all such details—this is manifestly impossible—but does mean an organization, theoretically effective, which has been made practically effective, one that brings results as the clock

counts the seconds—the man who winds the clock may leave it, assured that it will do its work; so the superintendent motive power, having his department properly organized, may leave it for periods of considerable length, assured that it will run properly because he has wound it up."

Prevent Train Collisions.

Train collisions with terrible loss of life are dreadfully common on our railroads. Within three weeks two dreadfully sanguinary disasters happened and accidents with the loss of a few lives are of almost daily occurrence. The daily papers which represent public opinion denounce the recklessness of railway companies for a day or two after an unusually fatal accident happens; make more or less impractical recommendations of preventions and then fall into silent apathy. That probably is a faithful reflection of the public conscience in regard to the constant killing and maiming of human beings. The blood of the martyrs is said to be the seed of the church, but it seems to take an awful measure of bloodshed to rouse public opinion into demanding the general introduction of safety appliances for the prevention of train collisions.

When the killing of trainmen had gone on for many years through the use of the crude appliances that were brought into use with the first locomotives and cars, public sentiment became sufficiently aroused to demand the introduction of certain safety appliances, and these have undoubtedly reduced the carnage they were designed to prevent. Efficient and effectual means can be introduced upon railroads that will entirely prevent collisions of trains if the companies will only go to the expense of installing the necessary apparatus.

When a bad railroad collision happens and the press tries to agitate for a remedy that will prevent loss of life from that source of recklessness, they nearly always demand changes that would be no remedy at all. Almost invariably the cry is for cars that will be strong enough to resist the shocks of coming violently together. If people during an epidemic of typhoid fever kept demanding more doctors and more hospitals instead of calling for the removal of the seeds of the malady, their efforts would be no less senseless and impracticable than the persons who demand stronger cars to prevent passengers from getting killed when collisions happen. The proper and practical remedy is in preventing collisions. This can be done by the general introduction of the block system, which prevents more than one train from being present on a guarded portion of track. The system is no untried experiment. It is in use on thousands of miles of track and there are no collisions where it restricts train movements.

The Board of Interstate Commerce Commissioners are to some extent responsible for so little being done to check terrible railway accidents that result from absence of protective apparatus. In Great Britain, where officials belonging to the Board of Trade exercise supervision over railways, with powers similar to those of our Interstate Commerce Commission, an investigation of every accident involving the loss of life is promptly carried out and the blame placed where it belongs. The reports of these investigations are published before the public have time to forget about the details, with the result that punishment is likely to be inflicted upon those responsible for the loss of life. Our Interstate Commerce Commission make reports of railroad accidents, and in some cases point out where the blame rested; but these reports are given out so long after the event they deal with that they are practically ancient history.

If this influential body, the Interstate Commerce Commission, which always has the ear of Congress, were to investigate every serious accident and report the finding of their experts within a month, there would soon be sufficient public sentiment excited to compel railroad companies to introduce proper means for preventing train collisions.

First Aid to the Injured.

The Pennsylvania Railroad has arranged for a series of lectures to be given to passenger, freight and work train men, engineers and firemen, yard masters, shop foremen, etc., on First Aid to the Injured. About fifty employees will be instructed at each lecture as to what to do in case of accident to any of their number or to passengers. This preliminary aid and care for the injured is to be given until the arrival of a properly qualified physician.

Baggage, mail, express, wrecking cars and work train cabooses will be supplied with standard stretchers. All these cars and the cabs of locomotives will be equipped with first aid boxes containing six anti-septic packets of bandages, etc., which the men are instructed how to use.

We venture to say that this excellent first aid instruction course will have in it some very emphatic "Don'ts." It is only natural that kindly and humane men will make some effort to aid a sufferer while waiting for a doctor, and it is of almost more importance to instruct such men as to the things they ought not and must not do, to a sufferer than to tell them what should be done. A properly conducted first aid course does not make railway employees into amateur surgeons. It gives them common sense rules of action, and bars out a lot of well

meant but dangerous practices in dealing with those who cannot help themselves

Book Review.

Self-Propelled Vehicles. By James E. Homans. Publishers, T. Audel & Co. New York, 1904. Price, \$2.00.

This book is now in its second edition and has been largely rewritten and revised. It is well illustrated throughout; contains 644 pages.

The general principles of automobile construction and operation, including steering devices, underframes, wheels, tires, bearings, lubricators are included in the opening chapters. Then follows an exhaustive account of the theory, construction and operation of gas engines, occupying over 100 pages. Several typical engines are taken up and discussed separately. The explanations of the governing devices are clear, while the dissertation on ignition, including the hot tube, and on primary and secondary sparks, cannot fail to prove of value.

Probably the most interesting feature of the work is the chapter devoted to the description of the leading types of gasoline vehicles, including the most important of American build. In this chapter the reader is informed as to the details of the transmission and control apparatus in each case. The book closes with a chapter on "Gasoline Vehicle Management;" another chapter on gasoline cycles covers the general principles involved in this type of motor. A full index at the close of the book puts its contents into ready reference form.

Traction Power Chart.

A new graphic traction power chart has just been published by the Derry-Collard Company, New York, which will be found a particularly useful reference for people interested in finding out the power of locomotives. It gives cylinder diameter by half inches from 15 to 45 ins., and strokes by 2 ins. from 20 to 36 ins. It also gives the cylinder volume in cubic feet for those who desire it. The directions give full instructions for use.

It will be seen by an examination of the chart that all diameters and strokes which intersect on any of the curves show cylinders of equal value and consequently equal power. In the same way, the relation between wheel diameters and steam pressure is also shown. This gives boiler pressure and mean effective pressure at the usually adopted 85 per cent. Alternate lines are made dotted for ease in following.

The charts are for sale by the publishers or in this office; price, 50 cents.

Danger from Overworked Trainmen.

In a public address, Lucius Tuttle, the able president of the Boston & Maine Railroad, recently discussed the prevalence of railroad accidents and their causes. An impression prevails that many of the accidents are caused by trainmen being overworked, which Mr. Tuttle said was not correct, so far as eastern railroads are concerned. In the West it is different. He said that the American railroads are largely operated on the mileage system, which offers the greatest incentive to employees to make as many trips as they may be permitted to make in order to increase their wages. This requires not the greatest coercion to induce them to run, but the greatest watchfulness to see they they do not run more than they ought to.

Canada's Railway Commission.

The Railway Commission of Canada is to a certain extent modeled after a department of the British Board of Trade, which is a government board having jurisdiction over all matters pertaining to land transportation. The Canadian Commissioners have power to not only ask for statistical information concerning any railroad accident in the Dominion, but they conduct a government investigation themselves on each disaster, and place the blame and prescribe the punishment and the remedy. The commissioners hold permanent appointments and report directly to the government, and their findings can be reviewed by parliament.

They are at present carrying on several investigations in order to ascertain the cause of some recent railway accidents in Canada, and they have lately called together a joint committee composed of representatives from all the Canadian railroads to agree on uniform running rules for all the roads, and when the commission approve of such uniform regulations, the regulations will have the force of statute law.

It is stated that the commission will insist that men running trains shall be compelled to take a certain amount of rest every day. The commission also contemplates compelling the installation of the block system on lines where traffic is, in their opinion, heavy enough to require the use of this kind of safety appliance. They will also order the installation of such a form of switch signal or route indication, that a switch cannot be thrown until after the semaphore signal has been appropriately set, indicating at a sufficient distance from the point of track divergence, which route has been "made" for an oncoming train. The Canadian Railway Commission are endeavoring to replace the haphazard idea by introducing the certain knowledge plan in railroad operation.

Direct and Indirect Valve Motion.

The introduction of the piston valve was largely due to gradual evolution of the locomotive from the comparatively light machine of former days to the heavy and powerful types used to-day. Larger cylinders and higher pressures required increased steam passages and more perfectly balanced valves.

With the advent of the piston valve the use of direct valve motion not only became possible but was advantageous. Our illustration, Fig. 1, shows a good example of direct motion, taken from the pages of the American Locomotive Company's recently issued catalogue.

valve the lines through the bulge of eccentrics lie on the same side of the vertical center line of the axle as the crank pin does. In other words, if the crank pin be represented by the figure IX on a clock dial, the eccentric center lines will read about twenty-five minutes to eleven, but if direct motion be applied to the outside admission piston valve or the D-slide, the crank pin still being IX, the eccentric clock would read about five minutes past five.

Our illustration, Fig. 2, shows the ordinary indirect valve motion with D-slide valve. The double-ended rocker is in evidence and the feature of this

Trans-Siberian Railway.

Russia's great Trans-Siberian Railway was begun May 19, 1891. It is as everybody knows the longest railroad in the world. It extends in an easterly direction from Moscow to the Manchurian border, where it connects with the Chinese Eastern, which crosses Manchuria. At Harbin the line branches, one branch going to Port Arthur and the other to Nikolsk. From here the road runs to Vladivostok. The distance from Moscow to Port Arthur is about 5,388 miles. That from Moscow to Vladivostok is 5,180 miles. Moscow to Harbin, 4,780 miles, and from Moscow to the station

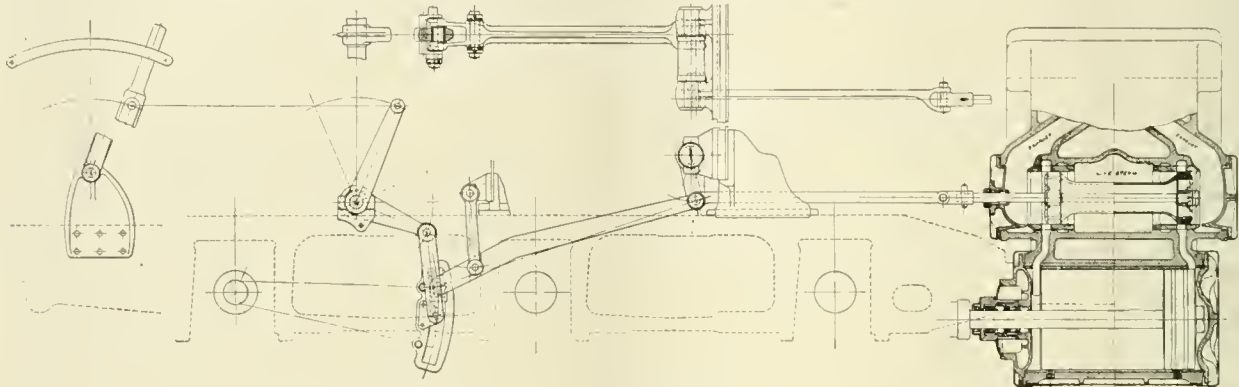

FIG. 1. DIRECT VALVE MOTION, WITH INSIDE ADMISSION PISTON VALVE.

It will be seen that the valve is one of the inside admission type. The double-ended rocker has been eliminated, the transmission bar passes over the axle of the second pair of drivers, and the

motion is that if the link block moves forward the valve will move backward and vice versa. If this motion be applied to an outside admission piston valve or a D-slide the eccentric clock

at the border of Manchuria, 4,197 miles. These lines were built in about ten years, but the construction was so poor that no sort of speed could be made. The government has therefore been forced to re-grade the line, lay heavier rails and substitute steel for wooden bridges, and, generally speaking, do the work over again. At one portion of the line Lake Baikal interposes a water stretch over which cars are ferried on an ice breaking boat. The lake is about 50 miles across at its widest part. A railway line will eventually be built around the southern end of this lake which will give uninterrupted rail communication. There will be some heavy tunneling on this link in the road.

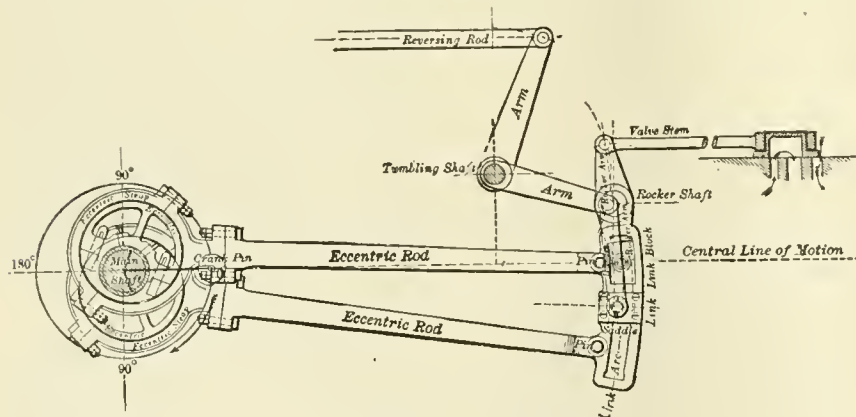

FIG. 2. INDIRECT VALVE MOTION.

central suspension feature, all taken together, justifies the name of direct connection.

With direct motion valve gear it must be remembered that if the link block moves forward the valve will do the same. In other words, link block and valve, move in the same direction at the same time. Direct motion can be applied to either an inside admission piston valve or to an outside admission piston valve, which, as far as setting is concerned, may be treated as the ordinary D-slide. When direct motion is applied to an inside admission piston

of which we have been speaking would show twenty-five minutes to eleven, as will be seen in the illustration, but if applied to the inside admission piston valve the lines of eccentrics and crank pin would mark five minutes past five. The direct motion has this much advantage over the indirect, that the indirect can usually be placed wholly within the frames and the piston valve chamber naturally comes in the cylinder saddle. In the inside admission piston valve the stuffing box is only subjected to the intermittent exhaust pressure and not to that of the live steam.

The famous Horace Greeley was a pious man but he acquired profanity in his boyhood while acting as operator at a way station and he never overcome the habit. One day when he was editor of the *Tribune* a reporter who attended a meeting of a farmers' club made fun of the proceedings and his account was duly printed in the paper. Greeley sent for him next morning and said, "You reported that farmers' club meeting and made them out to be a set of damned fools. That was entirely correct, but you oughtn't to have done it. They are a lot of fools, but it mustn't be said in the *Tribune*. Young man, I'm president of that Farmers' Club."

Our Correspondence School.

In this department we propose giving the information that will enable trainmen to pass the examinations they are subjected to before being promoted. If any of our students fail to understand any part of the instructions, we will gladly try to make them plainer if they write to us. When a student wishes to receive a private answer, he is reminded that it is usual to send a stamped envelope for the return letter. We will be glad to answer any question relating to railway matters, but prefer that they be suitable for our question and answer department. All letters intended for Our Correspondence School ought to be addressed to Department E.

Getting Ready for Promotion.

Railroad companies in general are introducing systems of examination of candidates for employment in train service and progressive examinations for promotion. We are here publishing a section of the questions in the third series of examinations submitted by a prominent railroad company and the answers required. The other questions will be answered monthly until the whole series is finished.

These questions are evidently made up with a few changes from different published works containing questions and answers for firemen, as a test of their fitness for promotion, and in some cases the selection has been so clumsily done that the questions seem vague and ambiguous.

By referring to question 21 our meaning will be clear. This question on its face refers merely to the keying of rod brasses, while the real intent and purpose is to ascertain the correct position of the engine in keying up the main rod, since question 23 refers to the keying of side rods.

Question 36 is open to a similar objection, since it may mean the changing of the eccentric rods to a longer or shorter radius affecting the lead, or it may mean the shifting of the eccentric rod to secure the correct travel of the valve over its seat.

We have before us pamphlets issued by several railroad companies containing examination questions, and they are all substantially the same with the questions arranged in a different order. Nearly all of the questions are answered in Sinclair's *Locomotive Engine Running and Management*, which was the basis of the instructions imparted by correspondence schools.

We are establishing an educational department in *RAILWAY AND LOCOMOTIVE ENGINEERING* which will contain answers to the railway companies' pamphlets until they are exhausted. We will then proceed with examinations of our own that will be as good as anything given by correspondence schools and will cost our readers nothing more than their yearly subscription to the paper.

Questions.

1. What are the duties of an engine-man before attaching the locomotive to the train?
2. What tools should there be on the locomotive?

3. What examination should be made after any work or repairs have been done on valves, brasses, etc.?

4. How can it be known whether a boiler is carrying the proper steam pressure?

5. What attention should be given to boiler attachments, such as gauge cocks, water glasses, etc.?

6. Is smokeless firing practicable?

7. Trace the steam from the boiler through the cylinders to the atmosphere, and explain how it transmits power?

8. How much power have the piston and crosshead on one side to turn the crank pin, when the center of the wrist pin, the crank pin, and the main driving axle on the same side are in a straight line?

9. How then is the engine kept going?

10. What is meant by "working steam expansively"?

11. How should the locomotive be started to avoid jerks and what train signals should be looked for immediately after starting?

12. After a locomotive has been started, how can it be run most economically?

13. If you discovered that a fixed signal was missing or was imperfectly displayed, what should you do?

14. How rapidly should the water be supplied to the boiler?

15. What is the difference between priming and foaming of a locomotive boiler?

16. What should you do in case of foaming in the boiler?

17. What danger is there when the water foams badly?

18. What work about a locomotive should be done by the engine-man?

19. How should the work of setting up the wedges be done?

20. How should rod brasses be keyed?

21. How should an engine be placed for the purpose of keying rod brasses?

22. What is the necessity of keeping brasses keyed up properly?

23. How should the side rods on mogul and consolidation locomotives be keyed?

24. What is meant by "engine out of tram"?

25. Why is it important that there be no holes through smoke box sheets or front and none in the smoke box seams or joints?

26. Describe a piston valve.

27. What is a balance slide valve? How is it balanced and why? For what reason is the hole drilled through the top of the valve?

28. What is meant by inside and outside admission valves?

29. What is the relative motion of main piston and valve for inside admission valve and for outside admission valve?

30. What is the difference in the valve motion for outside admission valves and inside admission valves?

31. What is a direct motion valve gear? What is an indirect motion valve gear?

32. What is meant by lead?

33. What is meant by steam side lap?

34. What is meant by exhaust side lap and by exhaust side clearance?

35. With an indirect valve motion, what would be the position of the eccentric relative to the crank pins? With direct motion valve gear? Why?

36. What effect would be produced upon the lap and lead by changing the length of the eccentric rods?

37. Why are eccentric rods made adjustable?

Answers.

BY JOSEPH A. BAKER.

1. The duty of the engine-man is to thoroughly inspect his engine for possible defects of machinery. He should know the condition of the fire box, grate bars, etc.; that gauge and water glass cocks are open and working freely, and that the crown sheet is covered with sufficient water to protect it from injury, and that the tender has been supplied with water. He should also know the condition of the engineer's brake valve and air pump, and take such other precautions as would prevent an engine failure.

2. The engine should be provided with such tools as are found necessary in every day work. This includes also tools with which to make repairs in case of accident. Rake, coal pick and shovel are classed as tools.

3. A man should satisfy himself by personal inspection that the work has been properly done, that all movable parts have been returned to place and properly secured by set screws or otherwise.

4. By the safety valves and steam gauge, which should correspond with the prescribed pressure as established by the company and posted in the engine cab.

5. It should be known that they are open and working freely at all times.

6. Not without the co-operation of the company in providing proper draft appliances and perfect condition of the fire box.

7. Steam enters from the main throttle located in the dome into the dry pipe, thence to the steam pipe and into the steam chest. From the chest it passes through the admission port into one end of the cylinder and forces the piston to the opposite end. When the piston has very nearly completed the stroke, the movement of the valve, which is in the opposite direction to the movement of the piston, establishes communication with the exhaust passage and permits the steam to pass through the exhaust passage into the stack and thence to the atmosphere.

8. None whatever.

9. Since a locomotive consists of two complete engines whose main rods transmit their power to the same driving shaft

tion in which the locomotive is expected to move, and a gradual admission of steam.

Signals should be carefully looked for towards the rear end of the train to make sure that the entire train has been started.

12. By working steam expansively, that is, with the reverse lever cut back to a point where the engine will handle her train with a full throttle.

13. Stop. Ascertain the cause and report to the proper official from the first telegraph station as per standard or special rules covering this subject.

14. Water should be delivered to the boiler steadily and in just sufficient quantity to replace the water which has been evaporated in doing work.

15. Priming is produced by certain

crowns sheet to the intense heat and liability of burning it.

18. He should set up the wedges and key up the rod brasses.

19. The engine should be placed with the crank pin of the right side on the upper, forward eighth, which brings the crank pin of the left side on the back, upper eighth. Block the wheels, and with the reverse lever in the forward motion, apply a small quantity of steam. As the action of the steam against the piston has a tendency to move it forward, the strain is thrown against the shoes, permitting a free movement of the wedges. The wedges should be set up with an ordinary wrench as far as possible and then pulled down again about one-eighth of an inch to prevent the box from sticking either from overheating of the box or defective lubrication of the wedge.

20. The key should be driven down just enough to bring together brass to brass. Any greater force would spring the crown of the brass against the pin and cause it to heat.

21. That depends entirely on which rods are to be keyed. If the main rod is to be keyed, place the side of the engine upon which the work is to be done either on the upper, forward eighth or the lower, back eighth, as these positions present the greatest diameter of the pin to the rod brass and guarantee a free movement at all points without binding.

22. To prevent unnecessary shocks and heating of rod brasses and pounding in driving boxes, which in time cause undue strain on the entire motion with disastrous consequences.

23. Place the engine on the dead center either forward or back. First key the middle connection, next the ends of rods and observe that the rod moves freely on the pin. Now place the engine on the opposite dead center and notice if the rods move freely at this point also. This is particularly necessary with rod brasses having keys on both sides of pin and which are apt to be made either too long or too short, throwing the rods out of tram and causing undue strain on rods and driving boxes, and also danger of broken rods or pins.

24. By an engine out of tram is meant one whose distance from center to center of axle or rod on one side does not coincide with the similar distance on the opposite side; or it may mean that the distance between two connected crank pins is not the same as the distance between the two axles to which the crank pins belong.

25. There should be no possible chance for the admission of air to any part of the smoke box, because it tends to destroy the vacuum necessary to create a perfect draft on the fire and also fans fires in the smoke box that warp and destroy the sheets or front end.

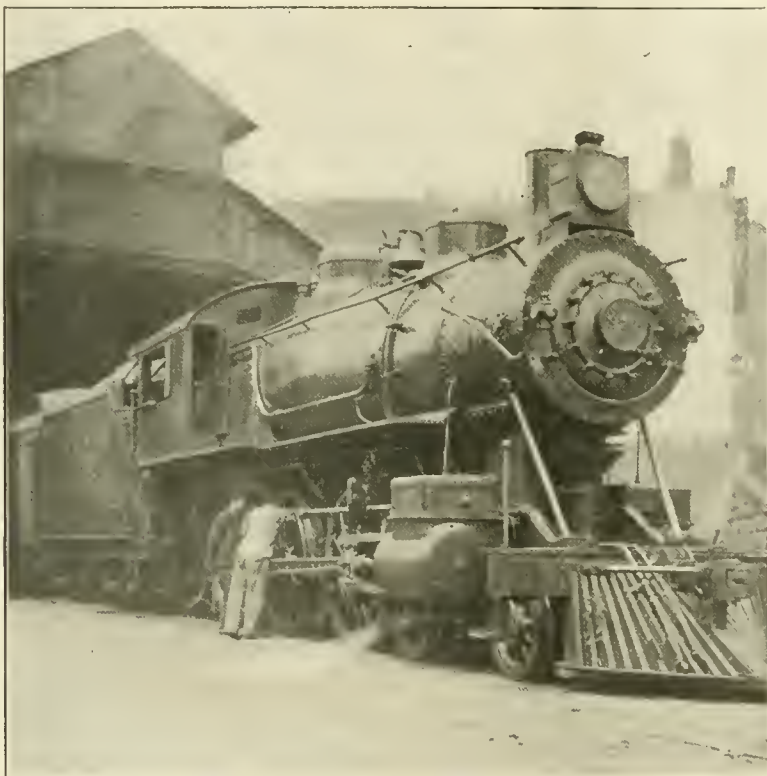

'LOCOMOTIVE ENGINEERING' SAYS IT'S THAT WAY, AND YOU SEE IT IS.'

upon which the main pins are at right angles to one another, it follows that the engine whose main pin is on either the top or bottom quarter exerts sufficient power to cause the wheel to rotate, carrying the pin on the opposite side past the dead center to a point where the steam becomes effective to move the engine on that side.

10. By working steam expansively is meant the process by which steam is let into the cylinder and cut off before the piston has finished its full stroke, thereby allowing the expansive force of the steam to exert a certain amount of energy on the piston from the time that cut-off took place up to the point where release occurs.

11. The engine should be started with the reverse lever in full gear in the direc-

conditions of the water and has a tendency to raise the water in a solid mass, while foaming consists of an aggregation of bubbles which carry the sediment to the surface. In both cases water is carried with the steam to the cylinder. To the ordinary observer priming and foaming are the same thing.

16. The throttle should be either partly or entirely closed for a few moments to ascertain the water level in the boiler. Where surface cocks are used, they should be used while the engine is at work, because they will then carry away the scum which has been driven to the surface. When recourse is had to the blow-off cock, it can best be done when the engine has been shut off, as the sediment then settles to the bottom.

17. There is danger of exposing the

26. A piston valve is a cylindrical, spool-shaped device having cast iron packing rings spring into place on the valve, and operating in a cylinder of equal diameter. The valve cylinder is provided with suitable admission and discharge ports and permits the valve to perform the same functions as an ordinary slide valve.

27. A balance slide valve is one where a certain percentage of the steam pressure exerted on the top of the ordinary slide valve has been removed.

The balancing feature is obtained by a steam table extending beyond the extreme travel of the valve, and either bolted to the steam chest cover or cast in one piece with it. The Allen-Richardson valve has its valve grooved for the reception of four snugly fitting strips, which are supported against the table by semi-elliptic springs, which make a steam-tight joint, and prevent any pressure reaching the enclosed part of the valve. The American balance valve obtains the same results but uses circular, tapering rings supported by coiled springs.

The small hole in the top of the valve is for the express purpose of allowing any pressure or water which may have accumulated on the top of the valve from whatever cause to escape to the exhaust port.

28. By inside admission valve is meant one where the steam enters the steam port of the cylinder from the inside edge of the valve and is exhausted from the outer edge of the valve; by outside admission is meant one where steam enters the steam port from the outer edge and is exhausted from the inner edge, similarly to our common slide valve, which is an outside admission valve.

29. With inside admission the motion of the valve is in the opposite direction to the piston's motion at the beginning of the stroke. With outside admission the movement of the valve is in the same direction as the piston at the beginning of the stroke.

30. Both may have either direct or indirect motion, according to the position of the eccentrics on the shaft and the type of rocker arm used.

31. A direct motion valve gear is one that transmits the motion of the eccentric to the valve direct by means of a transmission bar or a rocker shaft upon which both rocker arms hang suspended in the same direction.

An indirect motion valve gear is one where the power is transmitted from the eccentric to the lower rocker arm, which by its motion forward forces the upper arm backward, so that the travel of the eccentric is diametrically opposite to the travel of the valve.

32. Lead is the amount of opening a valve has when the piston is at the beginning of the stroke.

33. By steam side lap is meant the amount of the valve overlaps the steam

ports, when the valve is on the middle of the seat.

34. Exhaust side lap is the amount the inner edge of the valve overlaps the steam ports when the valve is in the middle of the seat.

Exhaust side clearance is the amount the inside edge of the valve comes short of covering the ports when the valve is in the middle of the seat.

35. If the valves are the inside admission indirect, necessitating a rocker shaft, the eccentrics would lean toward

when the crank pin is on the forward dead center; the eccentrics rods with the outside admission direct are also crossed when the crank pin is on the forward dead center.

These positions of the eccentrics are necessary with the corresponding valve motions to secure correct movement of the valves.

36. Changing the length of the eccentric rods will either increase or decrease the travel or produce an uneven travel of the valve over the ports, causing either



MOUNT PILATUS RAILWAY, SWITZERLAND, PASSING THE WOLFORT GORGE.
(Courtesy of the *Scientific American*)

the fire box when the main pin is on the forward dead center; while an outside admission indirect has the belly of the eccentrics leaning toward the main pin.

With an inside admission direct and a transmission bar, both eccentrics lean toward the pin; while with the outside admission direct the eccentrics have the same position as with the inside admission indirect. With the inside admission indirect the eccentric rods are crossed,

or a too early or too late admission and release. It depends entirely on whether one or both rods have been shortened or lengthened. It affects the engine in that a too early admission on one end would give a too early release, and a too late admission a too late release on the other end. Changing the length of the eccentric rods does not affect the valve lead. Positive lead can only be obtained by advancing the eccentric toward the pin with the ordi-

nary slide valve and indirect motion, while negative lead under similar conditions requires the eccentric to be turned from the pin.

37. To allow for adjustment of the valve travel so that even steam admission may be made at both steam ports.

(To be continued.)

GENERAL

Questions Answered

SUSPENSION OF THE LINK.

(72) M. P. B. R., Gainesville, Mo., writes:

What is the purpose of hanging the link on a stud set behind the center? Would it not be better balanced if placed on the exact center? A.—The irregularity of the connecting rod tends to delay the cut-off during the backward stroke of the piston and accelerates it during the forward stroke. Hanging the link back of the center corrects the irregularity of cut-off. You ought to study Halsey's book on Locomotive Link Motion.

BROKEN RAIL JOINTS.

(73) R. Y. B., St. Louis, writes:

Why do some railroad companies lay the rails so that the joints on one side come in the middle of the opposite rail? That causes the locomotive to have a rolling side motion very disagreeable, and to my belief dangerous. Why not always put the joints opposite each other? A.—The so-called broken plan is very well adapted for a solid track and distributes the weight of the shocks imparted by the wheels to the joints. It is not adapted to a yielding track and ought not to be used on such a roadbed as the rolling motion given to the engine is sometimes positively dangerous.

WHAT GAUGE PRESSURE MEANS.

(74) A. M. S., Winona, Minn., writes:

We have been having a little dispute about the pressure shown on a steam gauge. One side of the engine says it is absolute pressure and the other side says it is the pressure above the atmosphere. Which side is right? A.—The steam gauge shows the pressure above the atmosphere, which is 14.7 pounds above vacuum. Absolute pressure counts above vacuum.

CHANGES ON WATER.

(75) Apprentice, Brooklyn, N. Y., writes:

I think it would be helpful to young readers if you would describe the changes that can be made on water by heat and cold and tell something more about it than most of us know. A.—Water known to chemistry as hydrogen monoxide (H₂O) is the most abundant substance in Nature. The composition is 8 parts by weight of oxygen to 1 of hydrogen or by bulk 1 of O to 2 of H. Water

becomes ice at 32° F., and its greatest density is at 39 F. When it falls to the freezing point it expands, and has its greatest bulk at the freezing point, which accounts for vessels being broken where water freezes. Water boils at 212° F. at sea level, where the atmospheric pressure is 14.7 pounds to the square inch, and the boiling point falls as the pressure decreases, and rises as it is increased. At an atmospheric pressure of 10 pounds the boiling point is 193.2 F., and with a steam gauge pressure of 100 pounds the boiling point is 337.5 F.

VALVE GEAR AND LOCOMOTIVE SPEED.

(76) F. S. F., Mattoon, Ill., asks:

1. Will a valve with a 3 in. travel have the same power and speed as a valve with a 6 in. travel—cylinders 24x26 ins., 1¼ in. ports? A.—No, the valve with the 3 in. travel will open slower and to a less amount, and will close slower and earlier.

2. Does not large valve travel have a tendency to retard the speed of a locomotive? A.—No, it tends to accelerate the speed by giving freer access and exit to the steam.

3. Does compression exist in the cylinder when the slide valve is working? A.—Yes; compression begins in the cylinder when the valve shuts off the flow of steam from the port when exhausting. This point on an indicator diagram would be called "point of compression" or point of exhaust closure.

4. What do you think are the very essential parts for a very high speed locomotive? A.—Well designed valve gear, large boiler capacity, properly proportioned cylinders and suitable wheels and the largest exhaust tip that can be used.

5. Could a driving wheel with a diameter of 10 ft. be used on a locomotive? A.—Yes; wheels of that size have been used in Great Britain and in Germany, such wheels being usually single drivers. Other things being equal, the larger the wheel the less the tractive effort; very large wheels are not usually satisfactory.

6. Do you think it possible for a locomotive to attain the speed of 3 miles per minute? A.—No. Read the description of Pennsylvania Lines' engine, 8478, in the August, 1904, issue of RAILWAY AND LOCOMOTIVE ENGINEERING.

Pyle Headlight—Why Some Electric Headlights Fail.

First—Scale may have formed on the point of the copper electrode. As scale is a non-conductor, it prevents the current from passing through carbon point to electrode. The scale must be removed or there will be no light.

Second—Tension spring may be too loose. This will draw down magnet too far, cause a breakage of current and lamp will flash and go out. The spring

should be so adjusted that arc will not be broken when locomotive is standing still to insure a perfect light when locomotive is under speed.

Third—There may be a short circuit caused by defective insulation and contact of wires leading to the incandescent lamps. This will cause the light to go out. It will very much reduce the speed of the dynamo and produce a heavy current. Disconnect one of the small wires leading to the incandescent lamps and if the "short" is in the incandescent wires the light will burn.

Fourth—If there is a greenish light, the main wires from dynamo to the lamp have been connected up wrongly or the dynamo is speeded too fast. If throttling the steam and reducing speed of dynamo has no effect, change the main wires, because that is where the trouble lies.

Fifth—If light goes out when running fast, tension spring is too tight or clutch spring is too weak and prevents solenoid from separating carbon points sufficiently to form the proper arc.

Edwards Headlight—Failures, Cause and Remedy.

1st. If the light goes out, examine the leads to the dynamo and the connections at the lamp terminals, also the negative holder; if these connections are loose the light will fail.

2d. A dirty commutator. This prevents proper contact of the carbon brushes. Clean it by applying No. 0 sand paper while commutator is revolving slowly. The mica insulation between segments of commutator should never come above surface of commutator.

3d. Dynamo brushes out of position. See that the top brushes bear on the commutator and so placed that they are directly under middle bolt of dynamo frame.

4th. Lamp not feeding properly; carbon may be crooked or lamp rods dirty. Rods after cleaning should be left perfectly dry.

5th. Carbon not fastened securely. Drops out and often burns out carbon holder itself.

6th. Improper tension of springs to brush holder of dynamo. If springs are weak they should be taken up. Suitable notches are provided for that purpose.

7th. Imperfect light. Probably speed of turbine is insufficient. Speed should be about 1,850 r. p. m., and can be easily adjusted by increasing or decreasing tension of governor adjusting spring. A special adjusting nut is provided for that purpose.

8th. These are the causes of 90 per cent. of headlight failures, and by learning them and the remedies here given you can in a short time help yourself out of an emergency.

J. A. B.

Air Brake Department.

CONDUCTED BY F. M. NELLIS.

CORRESPONDENCE

Improved Oil Cup Cap.

I send you herewith a sketch of an improved cap for the automatic air cylinder oil cup, recently illustrated in your paper. This improved cap was designed with a view of determining whether we could not control the rate of feed better than with the style cup as first sent out. Practical experiment seems to verify our belief that the arrangement shown in this

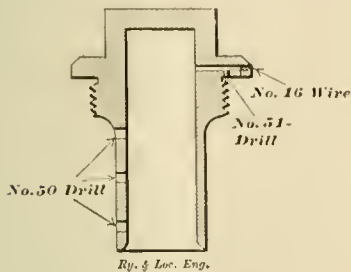

IMPROVED OIL CUP CAP.

sketch gives practically a uniform feed of oil and a much larger degree of economy in the use of oil for the air cylinder. It will be noted that these additional ports give a larger opening for the air from the cylinder of the air pump to reach the oil chamber of the air pump, thus giving a better result in lubricating effect.

J. P. KELLY.

Watertown, N. Y.

Adjustable Target Gauge Tester.

The accompanying drawing represents a dial to be used on a gauge tester for

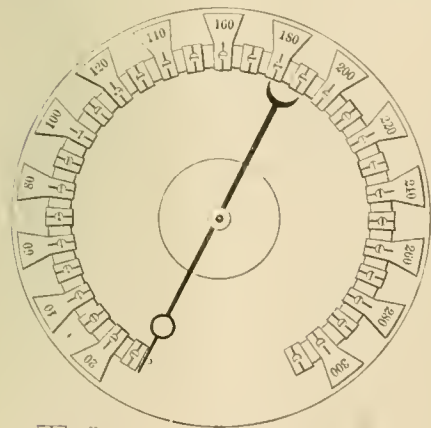

Ry. Loc. & Eng.

ADJUSTABLE TARGET GAUGE TESTER.

general use. The targets are adjustable, to allow for the variations liable to occur in most styles of test gauges.

This dial was designed at the Pennsylvania Railroad machine shops at this place, and has been in daily use for some time, giving perfect satisfaction.

The idea of the targets being adjustable, is, that the dial can be made correct at all points, by comparison with a mercury column, or with a weight tester.

R. N. MARTIN,
A. B. Repr. P. R. R.

Renoza, Pa.

Train Pipe Leakage, and Speed of Air Pump.

Since the introduction of very heavy motive power and the increased number of cars in trains, also the Interstate Commerce Commission, which pass laws that govern the safe handling of these trains, it has brought the attention of some railroad officials to the importance of properly maintaining the air brakes on their engines and cars. The general air brake inspector, to whom the officials look for the proper care of brakes, must therefore receive the support of his superior officers to bring about the best results which can be given. If he is given this support there can be no question as to the good results he will obtain.

Air brake instruction to enginemen and trainmen goes for naught unless the equipment is properly maintained. An engineman may thoroughly understand the brake system, but if the brakes are not in proper condition it will be impossible for him to handle long, heavy trains without doing serious damage to the equipment.

It has recently come to my notice that a number of roads are having considerable trouble due to air pump failures, which are chargeable to engine failures. One general air brake inspector on a certain road reports that he can't keep the reversing plate screws from breaking off. The nuts come off air piston. The piston rod is broken off in the steam end. Discharge valves are broken. Discharge valve seats are badly worn. These are common defects, and all caused by fast running of the air pump.

I feel safe in saying that in less than two years, all railroads hauling long trains of from fifty to one hundred cars, all air brake, will place a speed limit on the pump, not to exceed 140 single, or 70 up and 70 down strokes per minute. To do this it will be necessary to have enginemen instructed to time their

pumps for ten seconds or so. If the speed does not exceed 22 to 24 single strokes in ten seconds, it is running at a proper and economical speed.

Fast running overheats pumps, breaks discharge valves, piston rods, reversing valve plate screws, evaporates lubrication, and destroys that for which it was made—compression—in so short a time that the expense of maintenance is enormous. When the officials decree that a limit of speed (140 strokes I have found to be the best limit) shall be placed on air pumps, it is up to the general air brake inspector to get the car brakes in proper condition. This can easily be done by the installation of plants at terminals, giving the inspectors a chance to adjust piston travel and reduce train pipe leakage before the road engine couples to the train. I find that the following instructions to enginemen cover the points in question nicely:

Engines having 50,000 cubic inches main reservoir capacity, with brake valve handle on lap position, should charge main reservoir from zero to 100 lbs. pressure in 4 to 4½ minutes, with a pump speed of 130 strokes per minute. An air pump which will do this is capable of handling 100 cars of air with a train pipe leakage of 4 lbs. per minute, the pump not exceeding 140 strokes per minute. Enginemen when coupling to 50, 75 or 100 cars of air, must not allow the pump to exceed 140 single strokes per minute at any time.

A 9½ inch pump, running at 140 single strokes per minute, will not, if properly lubricated, become overheated, and will charge a 50 car train in 12 to 15 minutes, with a train pipe leakage of 5 lbs. per minute, having main reservoir charged, of course, before coupling to the train. If this leakage is increased to 9 lbs. per minute, it is impossible, with this speed, to properly maintain above 60 lbs. pressure. It is also impossible for an engineman to handle a train without breaking knuckles and drawheads with this amount of leakage. Why, then, should we increase the speed of the air pump when, with bad leakage existing, we are increasing the liability of damage to equipment? Why should we invite stuck brakes, due to train pipe leakage, as all railroad men are aware of the fact that in these long trains, train pipe leakage increases after the train has been stretched, or been stopped and started a few times, after leaving the terminal?

If a pump won't supply a train at 140 single strokes per minute, either the pump is in poor condition, and should be removed from the engine, or the train pipe leakage is excessive and should be properly inspected and repaired, before leaving the terminal yard.

If train pipes leak badly, don't try to maintain the pressure by running the pump at an excessively high rate of speed, but instruct the enginemen to refuse to leave the terminal yard until the train is in proper condition to safely handle without damage.

Three years ago, before the "Lackawanna" put this system in practice, it was impossible to keep sufficient pumps on hand to supply those that failed. To-day you can find an ample number of spare pumps on hand, and less men repairing same. All trains are being handled exclusively by air brakes, and all due to the enginemen not over speeding the pump and the train pipe leakage being reduced by the assistance of the yard testing plant.

There is no use asking enginemen to handle trains that cannot be handled properly, or that you would not attempt to handle yourself, or for suspending men for 10, 20 or 30 days for accidents for which they are in no way responsible. As enginemen feel that they are required to handle trains in a bad, leaky condition, they will naturally run their pumps to their full limit, and there will be pump failures, broken knuckles and drawheads for which the enginemen are really not to blame.

Satisfy yourself on what you consider the best limit of pump speed (I have found 140 to meet the requirements on our system), get in yard testing plants to reduce train pipe leakage, save delays on inspection, and also relieve the pump. In many cases the pump is overheated before the train line and auxiliaries are fully charged. Reduce train pipe leakage to suit an honest amount of work by the pump, instead of requiring the pump to suit itself to the excessive leakage found in the train pipe. This will entirely eliminate all the defects which I have mentioned.

P. J. LANGAN,

Genl. A. B. I.,—D., L. & W. Ry.,
Scranton, Pa.

Service Test of the Automatic Slack Adjuster.

The automatic slack adjuster that is now being generally adopted by railroads throughout the country, for the purpose of taking care of brake shoe wear, and relieving the air brake men of that strenuous duty, is a device whose operation is generally familiar to all air brake men. However, there has been a question in the minds of some as to whether the

adjuster operated each time the brake was applied, and whether the $\frac{1}{8}$ in. take-up at each operation was sufficient to care for the increase piston travel, which follows each brake application.

In order to gather some reliable data on this subject, whereby this question could be answered with some degree of intelligence, a perhaps crude but interesting test of this feature was recently made on a western limited train. The results showed that the adjuster was equal to the work required of it.

The test was made on two cars in the same train, fitted with six wheel trucks, diamond "S" brake shoes, and braking at 90 per cent. The two cars were of different weights. The total leverage on one was 7.25 to 1, while the other had leverage of 10.28 to 1, a Crosby air brake recording gauge was attached to one of the brake cylinders, and tell-tales attached to the adjuster nuts on each car which registered the turns that were made.

During a run of 200 miles, in which 54 brake applications were made (with a mean cylinder pressure of 34 lbs.), and the train brought to rest 35 times, it was found that the adjuster nut on the car with the total leverage of 7.25 to 1 had made $2\frac{1}{2}$ complete turns, or 20 operations of the device. As a total of 54 brake applications were made, it indicates that it required approximately 2.7 applications of the brake to wear the shoes sufficiently to allow the piston travel to increase $\frac{1}{8}$ in.

On the car with the leverage of 10.28 to 1, the adjuster made $2\frac{3}{4}$ complete turns, or 22 operations, wherein the adjuster operated once to every 2.45 brake applications. It will, of course, be unnecessary to explain here why the adjuster on the car with the highest leverage operated more frequently than was the case on the lower leveraged one.

While it is true that the performance of the slack adjuster, in regard to brake applications, will vary in different kinds of service, particularly so in high speed brake service, it is believed that the conditions met with during this test are about the general average. As it was shown that approximately only 50 per cent. of the adjuster capacity was required to maintain standard piston travel on these cars, it would appear that $\frac{3}{8}$ in. take-up is sufficient to meet the most severe conditions.

As the mean cylinder pressure during the run was about 34 lbs., which is in excess of that required to compress the adjuster spring, there can be no doubt as to the operation of the adjuster each time the piston travel exceeds 8 ins.

I offer this, as it may be information to some of your readers.

GEO. S. DAVIDSON.

Minneapolis, Minn.

QUESTIONS AND ANSWERS ON AIR BRAKE SUBJECTS.

(79) W. E. W., Cincinnati, O., asks:

In changing your foundation brake gear from low pressure brake to the high speed brake, would you still use your pull rods which are $\frac{7}{8}$ in. in diameter, or should the rod be made 1 in.? A.—The Master Car Builders' Committee on High Speed Brakes recommends that no rods be used with the high speed brakes that are less than $\frac{7}{8}$ in. diameter.

(80) E. R. B., Columbus, O., asks:

What makes the low pressure piston of the New York pump rebound, or kind of flutter, at the end of the stroke, when it should stand still? A.—The air passage leading from the low pressure cylinder to the high pressure is either obstructed, causing the exit of the air from the low pressure cylinder to go through very slowly, or else there is leakage from the high pressure cylinder, back through the intermediate valve, into the low pressure cylinder.

(81) W. E. W., Cincinnati, O., writes:

In changing the foundation brake gear of a car with rods and levers, to operate with the high speed brake, should the levers and rods for a six wheel truck car be made lighter than the rigging for another six wheel truck car weighing over 100,000 lbs.? A.—This matter has been looked into very carefully by the Master Car Builders, who appointed a committee to develop the subject, and that committee found that there was so little difference in weight and strength of foundation brake gear required for six wheel truck cars weighing 80,000 lbs. and heavier six wheel truck cars weighing 135,000 lbs., that a compromise rigging was decided upon which would be strong enough for the heavy car and not unduly strong for the lighter car. This was done with a view of avoiding two sets of levers, rods, jaws and pins for the two classes of cars.

(82) J. McS., Syracuse, N. Y., writes:

I have noticed on some of our cars that the brake beams are too long, and allow the brake shoes to lap over the outside of the wheels. Often a flange is worn on the outside edge of the shoe, due to this lapping over. I also observe that some brake beams are bent in the middle, some being bent up, others bent down and others bent toward the direction of the pull on the beam. A.—Undoubtedly many of these beams are unfit for the service in which they are placed, being entirely too light and unable to withstand the stresses they are subjected to. The Master Car Builders at their last convention appointed a committee to look into the subject of metal beams and to reconsider the different dimensions of the beam. This should result in the building up of a stronger and more satisfactory brake beam.

A Southern Pacific Oil Burner.

The Southern Pacific Company have recently received from the American Locomotive Company some passenger and freight engines. The accompanying illustration shows a consolidation type of engine adapted for burning oil, built at the Schenectady shops. The Southern Pacific lines tap the oil regions of Texas and Southern California, and as the price of coal is high in that part of the country, the economical use of fuel oil on that system has long passed the experimental stage.

These 2-8-0 engines have cylinders 22x30 ins. and 57 in. driving wheels. The calculated tractive effort is about 43,300 lbs. The total weight is 203,500 lbs., of which 181,000 lbs. rest on the drivers. Engine and tender in working order weigh 338,600 lbs. All the wheels are flanged, and the weight distribution is arranged so that the two leading pair of drivers and the pony truck are equalized together with overhung springs and the

trucks are of the ordinary arch bar type. A few of the principal dimensions are as follows:

General Dimensions—Wheel base, driving, 15 ft. 8 ins.; total, 24 ft. 4 ins.; total engine and tender, 55 ft. 8 $\frac{3}{4}$ ins.

Valves—Greatest travel, 6 ins.; outside lap of slide valves, 1 in.; inside clearance, $\frac{1}{8}$ in.; lead of valves in full gear, $\frac{3}{8}$ in.

Wheels, Etc—Dia. and length of driving journals, 9 ins. & 10 ins. dia. x 12 ins.; main crank pin journals (main side 8 ins. x 6 $\frac{1}{4}$ ins.), 6 $\frac{1}{4}$ ins. dia. x 7 ins.; side rod crank pin journals, 1 F. & B. 5 $\frac{1}{2}$ ins. dia. x 4 ins.; engine truck, journals, 6 ins. dia. x 10 ins.

Boiler—Working pressure, 200 lbs.; thickness of plates in barrel and outside of fire box, $\frac{3}{4}$ in., $\frac{1}{2}$ in. & $\frac{5}{8}$ in.; fire box, length, 108 ins.; width, 66 ins.; depth, front, 74 ins.; back, 70 ins.; plates, thickness, sides, $\frac{3}{8}$ in.; back, $\frac{3}{8}$ in.; crown, $\frac{3}{4}$ in.; tube sheet, $\frac{1}{2}$ in.; water space, 5 ins. front, 5 ins. sides, 5 ins. back; crown staying, crown bars.

Tender—Journals, dia. and length, 5 $\frac{1}{2}$ ins. dia. x 10 ins.; wheel base, 18 ft. 0 in.

Old Time Railroad Reminiscences.

BY S. J. KIDDER.

MAKING ENGINES SMART.

I never thought it quite the proper

to make an engine "smart." To be sure, the said M. M. was not impelled to make such changes with a view of reducing coal consumption or to get other motives of economy but, rather, as a demonstration of talent in the direction of apparent improvement in the engine's performance. These efforts, however, not infrequently bore forbidden fruit, for when the master mechanic's favorite had demonstrated its superior qualities and started a rivalry it acted as an incentive and invitation to engineers whose engines were less favored in valve motion to duplicate or excel the work of the banner engine of the division or road. Of course, an engineer harboring such ideas of emulation usually labored under a disadvantage if he tampered with the valve gear, even were his abilities competent to make the desired changes, as his standing with the master mechanic might be jeopardized and as a result a higher boiler pressure was usually resorted to either by increasing the ten-

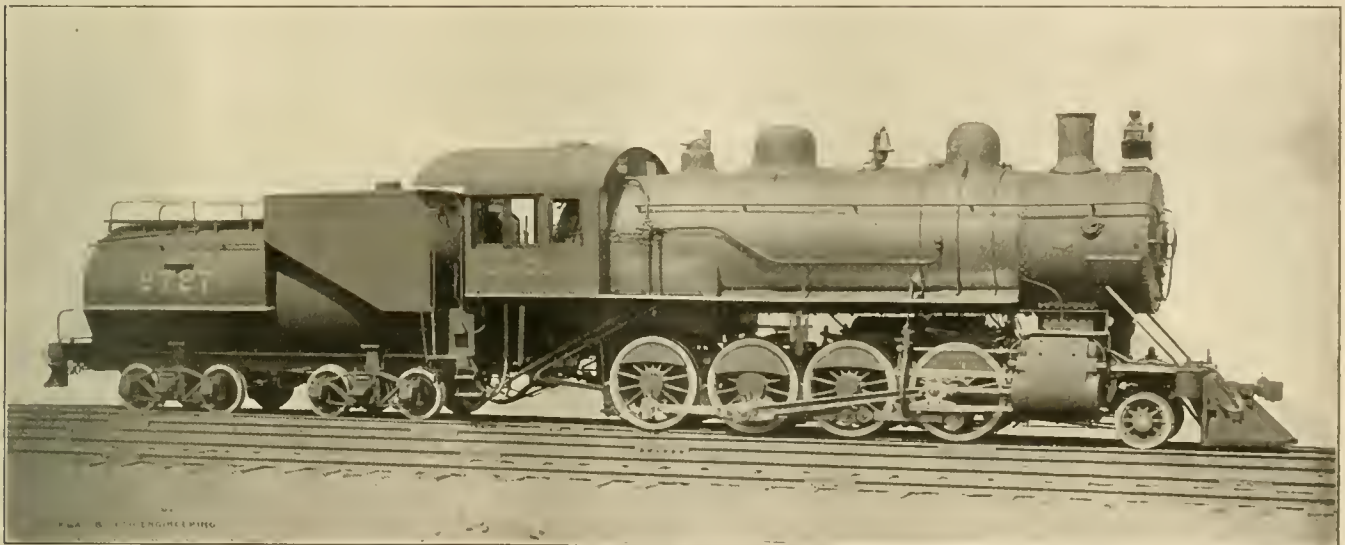

OIL BURNING ENGINE WITH VANDERBILT TANK FOR THE SOUTHERN PACIFIC.

H. J. Small, Gen'l Supt. of Motive Power.

American Locomotive Co., Builders

two rear pair of drivers are equalized together. The valve gear is indirect and actuates piston valves 12 ins. in diameter.

The boiler is of the straight top type, though the roof and crown sheets slope slightly toward the back. The gauge cocks are placed at a pitch of 3 ins., and the highest point of the crown sheet is 3 ins. below the center of the lowest gauge cock. Crown bars are used in staying the crown sheet. The diameter of the first boiler course is 80 ins., and the grate area is 49.5 sq. ft. The heating surface is 3,410.3 sq. ft. in all, there being 184.6 sq. ft. in the fire box and 3,225.7 sq. ft. in the tubes. The tubes are 15 ft. long and there are 413 of them.

The tender is the Vanderbilt cylindrical style and has a water capacity of 7,000 U. S. gallons and an oil capacity of 2,940 gallons. The tender frame is made of two 4x6 in. angle irons and the

thing for the mechanical department of a railroad to provoke rivalry between engineers running engines of supposedly the same type or class with a view of demonstrating that one engine under apparently identical conditions could pull more cars or run faster than another; neither did I believe that one man was getting a fair show when the valve gear of the other fellow's engine had been changed from an established standard resulting in making her "smarter than chain lightning." Many of my old time engineer friends can, no doubt, recall instances where the valve motion of a pet engine of some master mechanic—the old man always had his pet in those days as well as the engineer—surreptiously or otherwise received a few touches with a view of giving her the best of the others and at the same time prove to his superior officers his ability

on the scales and levers of the old-fashioned safety valves or tightening down the pop springs and rearranging the steam gauge so that the pointer registered the proper pressure allowable.

HOLDING DOWN THE SAFETY VALVES.

These thoughts are the result of observations during my early days of running an engine, and while I never cared to ride behind a boiler head withstanding an abnormal pressure, or had occasion to screw down the pops for the purpose of attempting a record against another engine on the road with which I was connected, there was, once upon a time, a temptation when prudence was temporarily thrown to the four winds, and I rode behind a boiler pressure the efficiency of which the deponent has never been able to determine as the pointer on the steam gauge had de-

scribed a complete circle and impinged the opposite of the pin against which it normally registered zero.

At the time referred to, Dan Scullen was pulling the Atlantic and Pacific express on the West End, between Creston and Council Bluffs, and might possibly have been running it now had he not pared a corn so deep with a razor that Nature failed to repair the rent, while I handled the same train on the Middle Division, we relieving each other at the former station. Dan had the "J. C. Hall," a new 16x24 engine. The old Hall, 14x22 Schenectady, or "Dutch Wagon," as they were known at that time, had been consigned to the scrap heap with nothing left of the defunct rattle-trap but the throttle lever, bell, driving wheels and name. These parts of the old machine had been utilized, however, to make possible the assumption that the engine had been rebuilt, which avoided the payment of a heavy government tax then imposed on new locomotives. To utilize the old driving wheel centers the Gen. M. M. had used eccentric crank pins which provided 24 in. stroke for the new cylinders, the side rods still retaining their original travel. It was about the first attempt of the old man to build a locomotive and he had made special efforts to turn out a superior article; but, as was common in old times, he built a 14 in. boiler with small fire box to supply 16 in. cylinders, and as a consequence the Hall always lagged for steam when Scullen was most desirous of securing it.

TRAIN RACING.

On the Middle Division, too, the passenger engines with 16x24 cylinders and 5½ ft. wheels were also shy of heating surface and to avoid occasional delays, a result of these express trains slowly creeping up or doubling the heavy grades, it was determined to convert the largest freight locomotive we had into a passenger engine and the "Winona," a nearly new 16x24 Manchester, was chosen for the purpose. Her boiler shell was originally intended for a wide gauge engine, but on a rush order the builder had finished it up with a large standard gauge fire box, resulting in making the Winona an excellent steamer, and with her 5 ft. wheels she proved a decided improvement over the cold water and big wheel "Arizona," which she superseded.

In the early '70s, three roads, the Chicago & North-Western; C., R. I. & P.; and Chicago, Burlington & Quincy paralleled each other from the Union Pacific Transfer to the outskirts of Council Bluffs, some three miles, but before reaching that city parted, the former turning to the left, the Rock Island bearing somewhat to the right, while the C., B. & Q. described a long curve as it

approached the depot, and, perhaps, a half mile beyond crossed the Rock Island at nearly a right angle. As the trains on the three roads were scheduled to leave the Transfer at the same time, it afforded an opportunity for some exciting races, but poor, old Dan, with the Hall, generally got the worst of it, for just so sure as he entered the race either the highly embellished McKay & Aldus, pulling the North-Western train, or the old Rogers, Ketchum & Grosvenor, of the Rock Island, or both, left him to bring up the rear. No one questioned Dan's nerve or skill, and when he related some of his encounters, during which the expletives rolled from his mouth nearly as rapid as the exhausts from the Hall's stack when running for a hill, it was clearly beyond question that the lost conflicts were a result of the want of steam rather than any lack of effort on the part of Dan.

Having frequently listened to Dan's recitals, and knowing I had an engine to be depended on for fog and a valve gear well approaching perfection, I got to wishing something would turn up whereby I might drop into Council Bluffs and get a pull-off against Dan's antagonists, believing, if afforded the opportunity, I could retrieve the fallen fortunes of the J. C. Hall. In course of time the hoped for occasion presented itself, and I permitted no obstacle to stand in the way of getting mixed up in one of those races. Coming into Creston one morning I turned the Winona over to the hostler and went to the hotel for the purpose of removing the accumulation of coal dust en route and had hardly set about so doing when the call boy rushed precipitately into the wash room and announced that the Hall had broken a link hanger in backing down to the train and my engine would have to go through to the Bluffs, ending up by saying the roundhouse foreman wanted to know if I would take the train to its destination. To this I readily assented and a few moments later was back to and hurriedly oiling the engine, which meantime was at the roundhouse taking coal and water. Preliminaries being disposed of, we returned to the train, coupled up and, a few minutes behind time, were soon rapidly passing over the blue grass prairies of Southwestern Iowa. Much of the division was over heavy grades with which I was familiar only to the extent of hearing the West End men discuss them, but the way was found with little trouble and we finally brought up at the Transfer at the hour designated in the time table.

During the trip considerable thought had been given to the race I expected would take place later in the day, and as our train was frequently heavier than those of the opposing engines, ways and means were considered looking to such

preparation as would meet any possible contingency that might be presented.

As to the Winona being able to keep up with the procession under equal conditions, I had no doubt, but regardless of such state of affairs, I proposed to win the heat if we got started off from the pole together. Accordingly, that noon, while the men about the engine house were eating their mid-day meal, I procured a pair of large bridge spikes, cut them off to proper length and inserted them in a vertical position with their bottom ends resting on top of the respective pop valves, the other under the yoke above, rendering the valves and their springs, set at 135 lbs., non-operative, regardless of the pressure in the boiler, after which my fireman and I sauntered off up town in search of dinner.

In those days it was the custom for the road engine to back its train from the yard near the city to the Transfer, and at the proper hour I got out of the roundhouse, took the train to the Transfer station, then waited for further developments and the time to arrive for our departure. While standing at the station the other trains backed down and took their places at the platforms and soon after our neighbors were sizing up the Winona and myself with apparently considerable interest, it being our first visit to the Missouri River Valley. Not long before leaving time I noticed the blowers were energetically working on the other engines and black smoke was beginning to roll in clouds from the smoke stacks; so, summoning Dan Smith, my fireman—Dan had gone over to the McKay and Aldus a few moments before to scrape acquaintance with the fuel agitator of that engine. I told him to put in a fire and get her hot. That Dan obeyed instructions was apparent, for when we got the signal to pull out, the North-Western engine having already started with a lead of two baggage car lengths, the steam guage pointer registered 172 lbs. and was still soaring in a skyward direction. For a short time the Winona failed to hold her own with the gorgeously embellished band wagon of the North-Western, gradually dropping behind until another car length intervened between the two big engines, the engineer of the J. M. Burke meantime smiling, and with his arm extended far out of the cab window motioning us to come on. The Winona by this time was settling down to business, and before the first mile was covered had overtaken her competitor and attained a slight lead, continuing her gain slowly but surely, every turn of the wheels.

As we gradually pulled away from them I occasionally increased the lazy cock opening—injectors were a luxury not afforded at that time—for the coal

my fireman had put into the fire box presaged that upon shutting off, as must soon be done, a superabundance of steam would be generated that, for the time being, those spikes would effectively prevent escaping to the ether above. Before reaching the point where the roads diverged the race had been fairly won, the word "fairly" being used advisedly—at least we had well distanced the Burke, though the Rogers with the lightest train of all was following a reasonably close second, and as the Winona struck the curve I closed the throttle, Dan put on the left hand pump, and to the time of bringing up at the station my attention was fully occupied in watching ahead and manipulating the brake valve.

Upon stopping, my first glance was toward the water glass; the next at the steam gauge, the pointer of which had passed the 200 figure and rested against the zero pin. Excitability is not one of my strong characteristics, but at that moment I got quickly and anxiously busy. Picking up a hammer I dove through the cab window, gave one of

two minutes," and as no apparent notice was taken of the numerous races over the rough mud ballasted track referred to, of course the master mechanic or other officers knew little or nothing of what was taking place there, though if such be true, it is somewhat significant that not long after my sortie at the Bluffs the old man called Scullen and myself into his private office, and, following some general conversation, said I could change by belongs to the 120, which he thought would make a good engine for my run, as he believed the Winona could be used to better advantage on the West End than the Middle Division; then, as he turned to his desk, he looked at Dan and remarked that if he saw anybody racing from the U. P. Transfer he would give him thirty days.

A prominent daily paper recently published a long editorial headed "The Locomotion End Seems in Sight." The article told about the acquisition of a number of electric railways by the Vanderbilt interests and of the movement

Advance in Locomotive Boiler Maintenance.

Locomotive boiler maintenance is an important subject to all persons connected with the management of railroads. In this connection we may mention that an instalment put in by the Pittsburgh & Lake Erie Railroad at its McKees Rocks, Pa., roundhouse, is producing valuable results, a brief description of which may be of interest. It is taken from the paper by Mr. A. R. Raymer, assistant chief engineer of the P. & L. E., which was recently read before the Western Railway Club.

This plant, he said, has been in successful operation since November, 1903, and by it foul water is removed from locomotive boilers; the heat is saved, and used in heating the water for refilling, and the boiler is refilled with water having a temperature of about 300° F.; the whole operation requiring only about 20 or 35 minutes, the time depending on the size of the boiler. If the condition of the boiler at the commencement of the operation showed steam pressure of 100

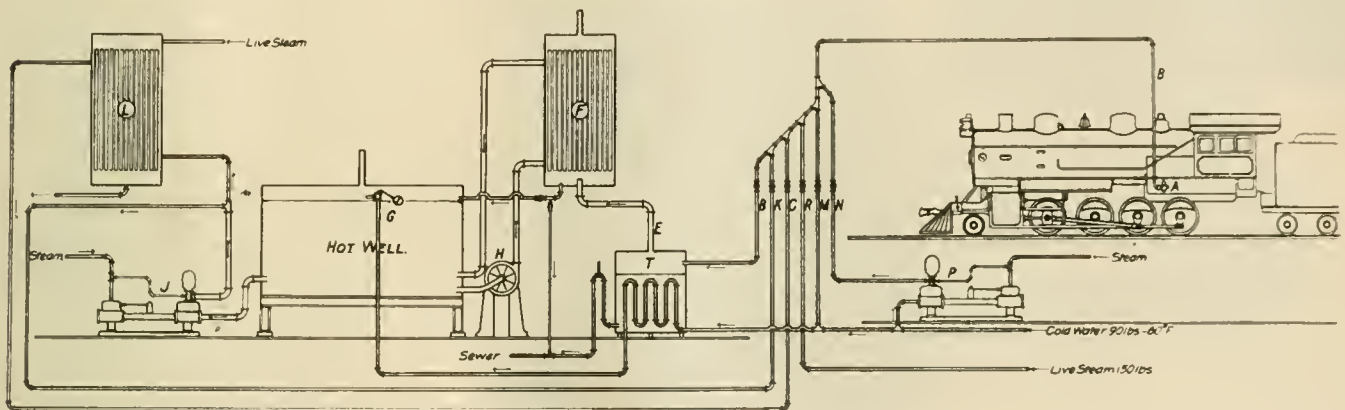

FIG. 4. DIAGRAM OF WATER CHANGING APPARATUS, P. & L. E. RAILROAD, MCKEES ROCKS SHOPS.

the spikes a sharp blow, which dislodged it, and the violent rush of steam through a pop set at 135 can better be imagined than described, and if there ever was a time when I was over anxious to get a go-ahead signal it was when I got back into that cab. The water in the glass was fluctuating spasmodically up and down, dropping lower and lower with each downward movement, while in my anxiety the length of the stop seemed to me to be never ending. Things, however, are not always what they seem, as in this instance the time was probably not more than a minute before Conductor Sam Childs gave us the "high ball," immediately following which there was a wild pull out and before reaching the Rock Island crossing the internal condition of the Winona, as well as my nervous system, had again resumed their normals. Among the time card rules displayed in conspicuous letters was one to the effect that "Under no circumstances must passenger trains exceed 30 miles an hour, or a mile in

to run passenger trains by electricity out of New York on the New York Central. The most extraordinary thing to us about that article is the number of marked copies sent to this office. If the people who were kind enough to do this intended to warn us that our occupation was nearly gone, they missed the mark. The steam locomotion has still a long life of usefulness ahead, and the end is far from being in sight.

The purpose of investigating smoke box devices is to find out what arrangements will best prevent spark throwing and at the same time call for as little restriction as possible to the draft and to the passage of steam from the cylinders. Investigations made by the aid of testing plants have demonstrated what combinations and proportions will give the best results under certain conditions; but they will not always help a run down engine using inferior coal to make steam so freely as certain other adjustments will.

to 125 lbs. per sq. in., and if the fire was banked, the steam pressure during the process will not fall below about 75 lbs. per sq. in. This water change is made without allowing any steam to escape into the atmosphere, and also without discharging any water on the floor of the roundhouse or into the pits. While this work is being done the changes of temperature in the boiler are very slight, being not more than 30°—say, from 350° F. to 320° F.

On many roads there exist conditions which make it desirable to "change" the water oftener than it is necessary to wash out mud or scale. A list of these roads include those which use water having alkaline or other soluble compounds that are not precipitated in the form of scale in the boilers. Other roads use waters which make a small quantity of scale that does not adhere to the metal, and lastly, the rapidly increasing number that have awakened to the importance and the economy of purifying water, by removing all scale-forming solids, and

mud in suspension, before the water is delivered to the locomotive boilers.

In all these cases there is a concentration in the boiler of the soluble compounds as evaporation continues, which results in "foaming" or "priming." The necessity for changing the water varies in time, depending on the condition of the waters used and the amount evaporated. The condition of the water on the P. & L. E. is such that it is necessary

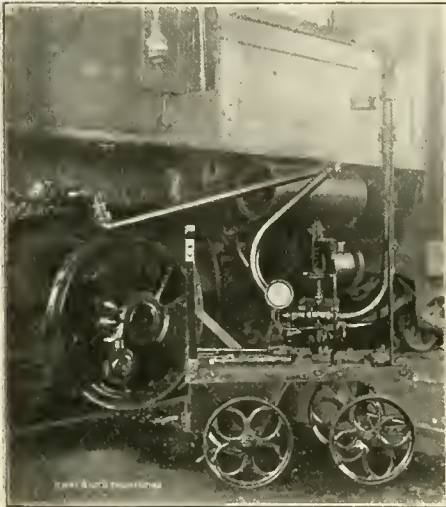

FIG. 1. WATER CHANGING APPARATUS CONNECTED TO LOCOMOTIVE BOILER.

to remove the plugs for washing only once in from 20 to 45 days; but during this time the water is changed on an average of about once every five days.

The benefits resulting from the use of treated water, in comparison with the conditions existing when raw locomotive feed water was used as pumped from the rivers, are clearly shown by a few facts taken from the records of this railroad. Comparing results in August, 1902, with those of August, 1904, raw water having been used during the former, and treated water during the later period, we find that the number of trains given up on the road on account of leaking boilers during August, 1902, was twenty-seven, while the number given up for the same cause in August, 1904, was two. The number of trains setting out cars, on account of boilers leaking, during August, 1902, was thirteen, while for August, 1904, no train did this. The number of through trains, during August, 1902, with delays of one hour or more, which had locomotives changed at McKees Rocks, on account of leaky boilers was thirty-one; while the corresponding number for August, 1904, was only three. Similar comparisons can be made from results already attained which show enormous advantages in favor of using purified water, in the increased life of flues, and of fire boxes, etc., and in the reduction of boiler maker's wages—in the increased service obtained from the locomotives and the reduction of

fuel necessary, on account of the removal of scale.

Locomotives requiring a change of water, have their fires cleaned in usual way and are sent to roundhouse preferably with fires banked and steam pressure about 100 to 125 lbs. Blow-off cocks have been placed in the left side of the fire box near the bottom as shown in Fig. 1. An overhead $2\frac{1}{2}$ in. blow-off pipe is located between the engine pits, with a pipe coupling placed about $6\frac{1}{2}$ ft. above the floor, opposite the blow-off cock in boiler, when the locomotive is in position in the roundhouse. The other end of the blow-off pipe connects with a manifold on the wall of roundhouse, shown in Fig. 2. A flexible pipe with necessary joints, gauge, drip cock and extension pipes for reaching blow-off cocks, is mounted on a light truck for convenience of operation, and is shown in Fig. 3. This flexible pipe truck is connected to the blow-off cock, and also with the blow-off pipe overhead, after which the valves

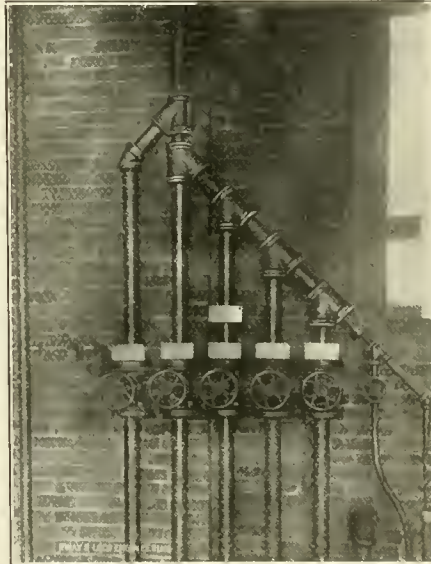

FIG. 2. "MANIFOLD" PIPE ARRANGEMENT FOR WATER CHANGING APPARATUS.

are opened and the water in the boiler is forced out by the steam pressure in 10 to 20 minutes. When water is all blown from boiler the blow-off valve in the manifold is closed and the "superheated" water valve is opened in the same manifold and the boiler is quickly refilled through the blow-off cock with this pure water at 300° F. and under 125 lbs. pressure, after which the valves are closed and the flexible pipe truck is disconnected. During this process there remained in the boiler a steam pressure of about 75 lbs. after foul water had been fully removed and the pure water was forced in against this pressure.

Manifolds, as shown by Fig. 2, are placed on the roundhouse wall, one for each of as many pits as it may be desired to serve; pipe mains are laid un-

der the floor in an accessible trench, one for each branch of the manifold. It has been found desirable to have the manifold include the following service pipes: Live steam, at about 150 lbs. pressure. Blow-off pipe, superheated water, at temperature of about 300° F. and with pressure of about 125 lbs. Hot water, at a temperature of about 200° F.; that is, the hot well temperature, and with a pressure of about 125 lbs. Cold water, at supply temperature, say, about 50° F., and at about 90 lbs. pressure. Test water, at supply temperature and at any desired pressure up to 300 lbs. per sq. in.

Live steam is used for heating up cold empty boilers; which can be safely done, in about ten minutes, bringing them up to about 300° F. The action of the steam on the empty boiler shell is uniform throughout and does not cause unequal expansion. Live steam is also used for increasing the temperature and pressure in a boiler full of water and under low steam pressure. The blow-off pipe from the manifold is used to convey blown-off water and steam to the blow-off tank. "Superheated" water is used for refilling boilers when water is "changed" for filling empty boilers after they have been "warmed up" by use of live steam. Hot water is used for filling boilers when hydrostatic test is to be made; hot water is also used to cool boiler shells quickly and safely. Cold water is used for removing mud, scale, etc., when necessary, by old way of washing. Test water is used for making hydrostatic pressure in boilers; this is furnished by a pump set to the pressure wanted, which pressure can be held as long as may be desired.

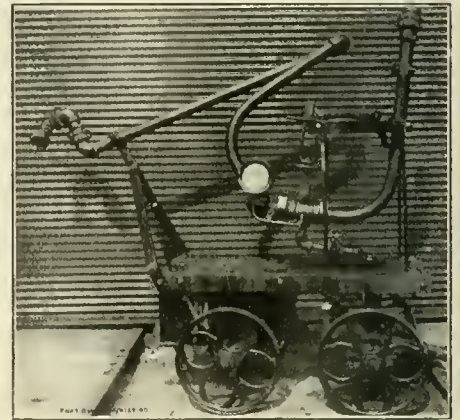

FIG. 3. TRUCK WITH PORTABLE CONNECTION FOR WATER CHANGING APPARATUS.

Fig. 4 shows a diagrammatic view of the whole plant. The blow-off pipe B, attached to blow-off cock A, conveys water and steam from boilers to blow-off tank T, which tank is closed and furnished with a pipe E to convey steam to condenser F, and if in excess to the atmosphere there will, therefore, be atmospheric pressure in the blow-off tank

T; consequently, the superheated water and steam blown from the boilers will immediately on arrival at blow-off tank drop to a temperature of 212° and all heat above that amount will pass in form of steam through pipe E to condenser.

A hot well is placed below the condenser; it is kept full of pure water by means of the float valve G. This supply water for hot well flows through coil in the blow-off tank, thereby extracting considerable heat from the foul water left therein, and reducing its temperature below 212° . A centrifugal pump H draws water from the hot well, and circulates it through the condenser F and back to the hot well, thereby condensing the steam and transferring heat to water in the hot well. The water of condensation also flows from the condenser to the hot well, or to the sewer as may be desired.

A hot water pump J is located below the hot well level, and draws water from it and forces it through the pipe K to the hot water valve in the manifold, and by pipe C through a live steam heater L to the "superheated" valve in the manifold. This pump is set for a constant pressure of 125 lbs. and is controlled by a steam pressure regulator. The test pump P is of the usual steam pressure regulated type easily adjusted for the pressures wanted, up to 300 lbs. per sq. in.

An ordinary freight locomotive boiler holds in working order about 2,500 gallons of water. This amount of water with steam at 100 lbs. has in it an amount of available heat above 212° F. equal to 2,600,000 British Thermal Units, and nearly an equal amount in the metal of the boiler shell and connected parts. The amount of heat blown from such a boiler at 100 lbs. pressure will evaporate about 2,700 lbs. of water at 212° F., and this amount of heat along with that saved from the foul water is sufficient to raise the refilling water from an initial temperature of, say, 60° F. up to 200° F. In delivering this refilling water to the boiler at, say, 300° F., the additional heat above that of the hot well, which is at about 200° F., is furnished by live steam from stationary boilers. No one will question the economy of drawing heat from a modern power house with mechanical stokers and high efficiency boilers, rather than trying to heat up locomotive boilers in the old way with smoky fires, with expensive artificial draught furnished by compressed air or steam.

The pumps, the blow-off tank, the condensers, and all of the plant, excepting the parts located in the roundhouse, are under the care of the power house men. One man in the roundhouse, at 18 cents per hour, does the work of changing water, heating and filling boilers, testing, etc. He can handle two locomotives in

an hour, if they are delivered to him so that he can operate on two or more at one time. At McKees Rocks roundhouse there are ten stalls equipped for the use of this plant, and four trucks are used in making the connections to the boilers.

The Andrews "Solid" Steel Truck.

Our illustration clearly shows the tendency of modern freight car construction towards simple and durable designs for trucks. This truck has been placed upon the market by Mr. J. S. Andrews, 114 Liberty street, New York, and is certainly an improvement over the arch bar type of truck. It is made of cast steel and embodies in its design all the important features of the arch bar truck without its defects.

In the engraving, one journal box and wheel are shown in position with the bolts securing them at the ends of what is really a steel girder with hinge strap at the bottom. The end of the truck to the right shows the wheel rolled out from the truck side and it will be no-

only in operation when a pair of wheels is being removed and the design obviates the use of a bolt or pin which could wear or cut or drop out.

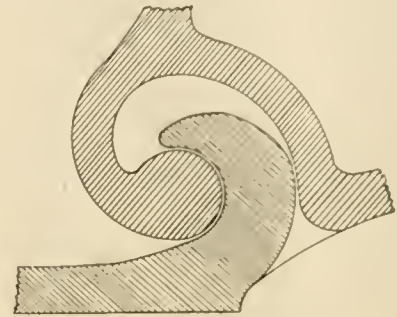

DETAIL OF HINGE FOR STRAP IN ANDREWS CAR TRUCK.

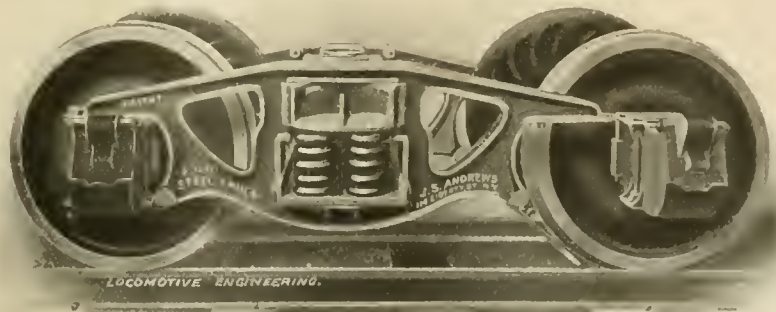

ANDREWS "SOLID" STEEL CAR TRUCK.

ticed that there are two dowels, one in the top member and one in the hinge strap, corresponding to the usual position of the inside bolt through the journal box. When the box is in position and the lower hinged portion is thrown up, these two dowels hold the box in position as ordinary arch bar bolts would hold it. When it becomes necessary to remove a wheel the work can be done in exactly the same manner as with the arch bar truck, and in case a single oil box has to be removed, it is obvious that it can be taken out with less labor as there is only one bolt to loosen. The central portion of the truck is arranged so that the bolster can be removed by taking out the springs and dropping it down into the wider space usually occupied by the springs.

The weight of this truck is considerably less than that of the ordinary arch bar type and its adoption by railroads will no doubt tend to lessen car truck repair bills.

The strap which passes under axle

A Close Call.

A dispatch to the *New York World* from Sharon, Pa., reads:

J. Chalmers Fox, a railroad fireman, was leaning from the window of his locomotive while crossing the Perryville Bridge last night and he was struck by some of the timbers and rendered unconscious. His body was dragged half way from the engine cab and he hung face downward.

Everyone thought he was dead, and when an undertaker from the lower part of the town took charge of the body, he rushed it to his rooms and stripped the "corpse" immediately for embalming. As he plunged the embalming needle into the flesh the arm of Fox gave a twitch. Fox an instant later rose from the marble slab and swore loudly at the undertaker who was so hasty about embalming him.

In speaking of his experience Fox said it was the jab of the embalming needle that roused him to consciousness.

Road Just As Wide.

G. Otto Krupp was the owner of an eight mile railroad, and a person of considerable local importance in the Pennsylvania German settlement where he resided. One morning it occurred to Mr. Krupp that by sending passes over his road to the presidents of the big railroads of the country he might receive complimentary passes in return. This would enable him to see something of the world at comparatively small expense, and such passes as he could not use personally he could dispose of advantageously. Mr. Krupp lost no time in getting letter heads printed, with his own name in large type, as president. Then he sent "R. and A." passes broadcast and awaited results.

One hot afternoon a flushed representative of a big western road walked into

Air Operated Rail Loader.

The American rail loader is an air operated machine which, as its name implies, is used for loading and unloading rails anywhere along the line. The loader consists of a small four-wheel truck with an upright post carrying an air cylinder and a jib from which hangs the steel cable and the tackle necessary for grasping the rails.

When in use the loader is anchored to a flat car and the jib projects as far as the center of the next flat car in front. Air to operate the hoist is obtained from the train pipe by means of a suitable rubber hose pipe. It is operated by a man who stands on the loader truck, and three other men make up the necessary "gang" to use the loader. An average of two weeks' work showed that the machine picked up, on

Newspaper "News" Concerning Railroads.

"About one hundred miles of the Long Island Railroad system will be operated by electricity early next spring." These words are the opening of an article in the *New York Tribune* of October 6. Enquiry at the head office of the Long Island Railroad elicited the information that although they are building a large power house at Long Island City for use in the proposed Pennsylvania tunnel system, the Long Island intend to operate a little more than twenty miles of their line by electric power. The portions of line to be thus equipped are Jamaica to Flatbush avenue, a distance of 9.65 miles, and from Woodhaven Junction to Far Rockaway, a distance of 11.76 miles, according to the Long Island time table, making a total of 21.41 miles. This is not quite such an extensive program as that mapped out by our esteemed contemporary.

Fortieth Anniversary.

Elaborate preparations are in progress by the Erie engineers at Galion, O., for the celebration of the fortieth anniversary of Division 16 of the B. of L. E.

Early in November, 1864, Mr. John Brunton, an engineer on the old Bee Line, now a part of the Big Four System, applied to the Grand Division of the Brotherhood for a charter, and on December 12 of the same year, Sub-Division 16 was organized at Galion. Most of the charter members have either passed away or moved to other parts of the continent, Mr. Brunton now being located on the D. & R. G., at Pueblo, Col. The members of 16 are very proud of the division's long life, since few of the old lodges are still in existence, the older numbers being in most cases borne by young lodges that have taken the surrendered charters of the original lodges.

The program of entertainment is to include a public meeting in the afternoon in which prominent railroad officials, public speakers and Grand Chief Stone will take part. In the evening there is to be a banquet and reception. An enjoyable musical program will be given by a chorus of trained female voices.

The Eric boys have never done things by halves, and all who attend this meeting are assured of a royal good time and cordial welcome.

Carlyle, the noted philosopher, was a very successful university graduate, but he had a very poor opinion of college education. One of his sayings was: "The true university of these days is a collection of books." The most direct help a young workman can have is some one who will tell him what books to select. We will always be glad to give our advice regarding books.

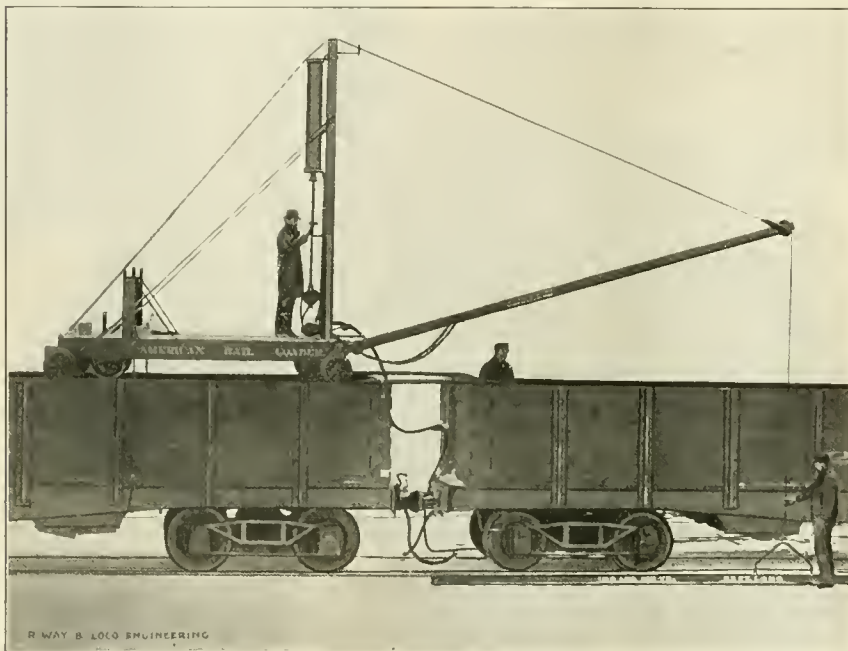

AIR OPERATED RAIL LOADER.

Mr. Krupp's office and said he had been all over town looking for the "R. and A." Railroad and could not find it. He said he was sent from Philadelphia to investigate before the company issued a pass over its entire line.

"It is chust outside of town—five minutes' walk," explained Mr. Krupp, suavely.

"How long is your road?" asked the railroad's representative.

"About eight miles, I t'ink."

"What! You don't expect us to exchange passes with a road like that, do you?" the representative demanded, angrily. "Why, we have eight thousand miles of road."

"Vell," answered Mr. Krupp, drawing himself up with an air of offended dignity, "maybe my road ain't so long as yours, but it's chust as wide."—*Lippincott's Magazine*.

the average, seventy rails per hour, for every working hour in that time.

The loader begins at one end of a train and clears the car in front of it. When that is accomplished the loader is moved forward onto the car it has just cleared, and so on over the entire train. This operation is reversed when a train is being loaded. The stroke of the cylinder and the pulleys employed give just the required lift and fall to raise the rail off the flat car and lower it to the ground, without any undue work and without loss of time, and the chances of injury to those engaged in handling the rails are very materially reduced. The United Supply and Manufacturing Company, of Chicago, handle the rail loader.

In this world none of us can have everything our own way.—*Little Dorrit*.

Of Personal Interest.

"Locomotive Engineering" in New Quarters.

Our many friends and correspondents would save time when they try to find us in New York, or when they write to us if they would bear in mind that our new address is 136 Liberty street. We have been compelled to move into more commodious quarters, as the constantly expanding business of RAILWAY AND LOCOMOTIVE ENGINEERING and of *The Automobile Magazine* have rendered this move imperative. Our offices are on the fifth floor of the New York Electrical Exchange building, on the corner of Liberty and Washington streets, but 136 Liberty street will always find us.

One of the most popular officials to be met with for years at the headquarters of the Illinois Central Railroad was Mr. Albert W. Sullivan, assistant second vice-president of the company. When any information was wanted Mr. Sullivan seemed always ready to give it, and favors were accorded with a cheerful grace that made them doubly valued. Mr. Sullivan entered the service of the Illinois Central in 1870, as an apprentice in the machine shops, and he gradually worked up to be assistant second vice-president, which he has just left to be

knowledge of useful things about railroad operations. His own class of railroad officials several years ago elected Mr. Sullivan president of the American Railway Association, an organization of which he is a very active member. We feel moved to offer congratulations on behalf of the mechanical department that another graduate through that school has moved to the top.

In November, 1903, we had the pleasure of recording the advancement of



MR. BENJAMIN L. WINCHELL.

Mr. Benjamin L. Winchell to be the third vice-president and general manager of the Chicago, Rock Island & Pacific Railway. He has lately taken another step upward and is now the president of this important system. Mr. Winchell has had a wide range of railroad experience; he began as a clerk in the office of the master mechanic on the Hannibal & St. Joseph Railroad, after which he passed through the auditor's office and entered the passenger department, and twelve years after he had entered railway service he became assistant general passenger agent of the Kansas City, Fort Scott & Memphis. Later on he became president of that system and when in time it was absorbed by the St. Louis & San Francisco, he was at once elected vice-president of this company. Mr. Winchell's well-known characteristics are fair and impartial dealing between man and man, clear headedness, untiring energy and the ability to select competent assistants. He is an old and valued friend of RAILWAY AND LOCOMOTIVE ENGINEERING, and his well-earned success

is a matter of pride and pleasure to his many friends.

Mr. Frank Hedley, formerly general superintendent of the Interborough Rapid Transit Company, of New York, has recently been promoted to the position of general manager of the same company. Mr. Hedley is a native of Maidstone, in the county of Kent, England, having been born there in 1851. He began practical work as an apprentice when 13 years old and when he had completed his time he came to the United States, where he worked in the Jersey City shops of the Erie Railroad. He went from there to the New York Central; after a short time he left that road to become an inspector on the Third Avenue division of the Manhattan Elevated Railroad in New York; later he became general foreman of the West Side division of the same road. Then he was appointed master mechanic on the Kings County Elevated Railroad in Brooklyn. His next move was to Chicago where he took charge of the Lake Street Elevated Railroad in that city. When the Interborough Company adopted electricity as a motive power on the New York Elevated, Mr. Hedley was offered and accepted the position of general superintendent, and he has now been



MR. ALBERT W. SULLIVAN.

general manager of the Missouri Pacific. He rose rapidly through the positions of draughtsman, chief clerk of the mechanical department, superintendent and general superintendent. His steady advancement was due to special fitness for the positions, and his own native energy coupled with the faculty in acquiring



MR. FRANK HEDLEY.

made general manager of the Interborough Company, the position of general superintendent having been abolished. He is the grand-nephew of William Hedley, who was the first man to make a practical locomotive, the famous "Puffing Billy," which was built in England in 1813. Mr. Frank Hedley is an-

other railroad manager who comes from the motive power department and by hard work and ability has won his spurs and has honorably kept up the traditions of his family.

Mr. Geo. R. Balch has resigned his position as purchasing agent on the Cincinnati, Hamilton & Dayton.

Mr. Fred W. Walker, has been appointed general foreman, Baltimore & Ohio Railway, C., L. & W. Division, at Holloway, Ohio.

Mr. Roger Atkinson, master mechanic in charge of the Philadelphia & Reading Railway repair shops at Reading, Pa., has resigned his position.

Mr. T. Hamilton has been appointed assistant master mechanic on the Pennsylvania Railroad, with office at Verona, Pa., vice Mr. J. B. Diven, transferred.

Mr. C. H. Bowers has been appointed assistant master car builder on the Canadian Pacific Railway for lines east of Port Arthur. His office is in Montreal.

Mr. Charles S. Clark has been appointed vice-president of the St. Louis, Iron Mountain & Southern Railway Company, in charge of its general operations and affairs.

Mr. William White has resigned as master mechanic on the Lake Erie & Western Railroad, at Lima, Ohio, to accept a position with the Chicago Pneumatic Tool Company.

Mr. Alexander G. Cochran has been appointed vice-president of the St. Louis, Iron Mountain & Southern Railway Company, in charge of the legal affairs and general contract relations.

Mr. G. Navarro, formerly master mechanic on the Ferrocarril Nacional de Mexico, at Acambaro, has been appointed superintendent of motive power on the Ferrocarril Vera Cruz & Pacific at Tierra Blanca, Est. de Vera Cruz.

Mr. G. H. Bussing, formerly assistant superintendent of motive power of the Evansville & Terre Haute Railroad, has been advanced to the position of superintendent of motive power of the same road with office at Evansville, Ind.

Mr. H. E. Herr, formerly master mechanic on the Norfolk & Western Railway at Roanoke, Va., has been appointed to the position of assistant to the vice-president of the Denver & Rio Grande, with headquarters at Denver, Col.

Mr. Alfred Price, formerly superintendent of the first district Central Division of the Canadian Pacific, has been appointed superintendent of transportation of the western lines of the same company, with office in Winnipeg, Man.

Mr. H. Osborne, formerly master mechanic of the Delorimier Avenue shops

of the Canadian Pacific Railway, in Montreal, has been appointed superintendent of the Angus shops of the same company, which are situated at Hochelaga.

Mr. John Hill, general foreman of the Kankakee shops of the Indiana, Illinois & Iowa Railroad, has been appointed master mechanic on the Lake Erie & Western Railroad, with headquarters at Lima, Ohio, vice Mr. W. White, resigned.

Mr. J. J. Scully, formerly assistant superintendent of the third district, Central Division of the Canadian Pacific Railway, has been appointed superintendent of the same district, with office at Brandon, Man. Mr. Scully came from the mechanical department.

Mr. F. B. Smith, formerly general master mechanic on the New York, New Haven & Hartford, at New Haven, Conn., was, on the occasion of his leaving that road, presented with a handsome and costly diamond ring. It was given to him by master mechanics and shop foremen of the road as a small token of their esteem and regard.

Mr. Ira C. Hubbell was elected president of the Locomotive Appliance Company, of St. Louis, at a recent meeting of the board of directors. Messrs. W. C. C. Squire, C. H. Howard and J. J. McCarthy were elected vice-presidents; Mr. J. B. Allfree was elected consulting engineer, Mr. W. H. England secretary, and Mr. E. B. Lathrop treasurer, of the company.

Mr. P. M. Cheney, for some months roundhouse foreman on the Atchison, Topeka & Santa Fe at Ratoon, N. M., has been appointed road foreman of engines on the same road with headquarters at Needles, Cal. Mr. Cheney at one time held a similar position on the Pere Marquette and he was also with the American Locomotive Company. His many friends will be glad to know of his success.

Mr. A. H. Gairns, formerly master mechanic on the Chicago, Rock Island & Pacific, at Omaha, Neb., has been appointed general foreman of the San Bernardino (Cal.) shops of the Atchison, Topeka & Santa Fe Coast Lines. Mr. Gairns entered railway service as general utility boy in the master mechanic's office of the Burlington, Cedar Rapids & Northern. Then he learned the machinist trade in the Cedar Rapids shops and has been moving upwards ever since.

Mr. D. A. Sweet has been appointed road foreman of equipment on the Chicago, Rock Island & Pacific Railway, of the Oklahoma Division, with headquarters at Chickasha. Mr. Sweet began his railroad career on the C., J. & M. Ry., now the Cincinnati Northern, as fireman, later took service with the F. Ft.

W. & W. Ry., now the Fort Wayne Division of the C., H. & D.-Pere Marquette System, where he ran a passenger engine for some years. He later took service with the C., O. & W. Ry., out in the territories. This line was absorbed by the C., R. I. & P. Ry. After about three years' service there he has been promoted to the position named. Mr. Sweet, while on the F., Ft. W. & W. Ry., took a leave of absence at his own expense, spent one month on the Westinghouse Instruction Car, while it was on the Erie Ry.; later, while it was on the Missouri Pacific Ry., he spent an additional week in the same manner.

Appointments to the Allis-Chalmers Company.

Mr. S. H. Sharpsteen, for a number of years with the General Electric Company as salesman at New York, has accepted a similar position with the Allis-Chalmers Company in their New York office.

Mr. James Ashworth, until recently engineer of the City of Chicago, in the department of water supply, has entered the employ of the Allis-Chalmers Company as salesman in their pumping engine department.

Mr. R. L. Richardson, for a number of years in the Pittsburgh sales office of the Westinghouse Electric & Mfg. Co., has become a member of the Pittsburgh selling force of the Allis-Chalmers Company.

Mr. John V. Redfield, after some years in the works and in the Chicago sales office of the Westinghouse Electric & Mfg. Co., has been appointed to the sales staff of the Allis-Chalmers-Bullock interests at their Chicago office.

Mr. Chas. S. Buell, mechanical engineer, who, until recently, represented the Westinghouse Machine Company in Chicago, has entered the employ of the Allis-Chalmers Company as salesman and engineer in their Power Department.

Mr. G. Fred Collins, who has a very extensive acquaintance throughout the East among officials and engineers of large railroad and steel companies, has recently entered the employ of the Allis-Chalmers Company as special representative at their New York office.

Mr. Chas. F. Ade, for several years in the employ of the Westinghouse Electric & Mfg. Co., Pittsburgh, Pa., and lately manager of the Pittsburgh office of the C. Lee Cook Company, has been appointed to the selling force of the Allis-Chalmers Co., at their New York office.

Mr. M. C. Miller, one of the leading men in the alternating current department of the Westinghouse Electric & Mfg. Co., Pittsburgh, Pa., has resigned his position with that company to accept a similar position with the Allis-

Chalmers Company in their electrical department.

Mr. Otto Clyde Ross, for several years employed with the Westinghouse Machine Company as engineer and salesman, and lately in the employ of the Hartford Lead, Zinc, Mining & Smelting Company as engineer, has accepted an appointment with the Allis-Chalmers Company as engineer and salesman.

Mr. John F. Burke, for a number of years with the Westinghouse Electric & Mfg. Co., in Omaha, Neb., has joined the selling force of the Allis-Chalmers Company with headquarters in Omaha, Neb., and will engage in the sale of Corliss engines, electrical apparatus and crushing and cement machinery for the latter concern.

Mr. Wilbur M. Ruth, an engineer of wide experience in both steam and electrical work and until recently assistant to the president of the Mesta Machine Company, Pittsburgh, Pa., and previously employed on the engineering staff of the E. P. Allis Company, has accepted a position as salesman and engineer for the Allis-Chalmers Company at their Pittsburgh office.

Mr. W. M. S. Miller, who was in the employ of the Westinghouse Electric & Mfg. Co., in the manufacturing, production and detail correspondence departments, and until lately in the detail and supply department, covering in all a period of some fourteen years, has joined the staff of the Allis-Chalmers Company with headquarters in Chicago.

We have a copy of that famous book, Clark's Railway Machinery, for sale in the Book Department of LOCOMOTIVE ENGINEERING. The book is now very scarce.

Neglecting the Stitch.

The writer fails to connect the lameness of the 49 and the lost cylinder head. What made the engine lame? It is evident the engine was using steam right along, and if so, and the cylinder head was giving way, why did not steam blow out? There is a missing link wanted in that story.

W. DE SANNO.

San Francisco.

The editor of LOCOMOTIVE ENGINEERING wishes to acknowledge warm courtesies received from Mr. John J. Hannahan, Grand Master of the Brotherhood of Locomotive Firemen, during the Buffalo convention. Mr. Hannahan invited us to address the convention, which was quite a privilege for a newspaper man to receive. The delegates received us with vociferous cordiality and listened to an address with manifest interest.

A Trip on the Big 2700.

BY ANGUS SINCLAIR.

Enginemens as a rule do not become enthusiastic readily concerning new designs of locomotives or over radical changes on old forms. They are inclined to cling persistently to the forms and mechanism that they have found by experience to produce a comfortable working engine and to look with misgiving at novelties, no matter how warmly the latter may have been praised even by the highest mechanical authorities.

With this knowledge of the conservative propriety of the men who run locomotives, I was surprised during a western tour to accidentally meet enginemens who talked quite enthusiastically of balanced four cylinder compounds. This was the more surprising owing to the well known dislike which locomotive enginemens as a class entertain for all kinds of compound locomotives. The praises of the four cylinder balanced compounds had been so earnestly repeated by different men on different railroads, that I determined on arriving at St. Louis to make an effort to enjoy the privilege of riding on one of these engines, and judging for myself the merits which had excited so much genuine enthusiasm.

By good fortune I discovered that engine No. 2700 belonging to the Chicago, Burlington & Quincy, which was illustrated and described in the October number of LOCOMOTIVE ENGINEERING, was pulling passenger trains out of St. Louis on the Hannibal division of the Chicago, Burlington & Quincy. Through the courtesy of Mr. F. H. Clark, superintendent of motive power, I received permission to ride on the engine from St. Louis to Hannibal. People interested in this account will better appreciate the work done, by examining the illustration and reading the description of the engine that appeared on page 465 of our October number.

The engine was built by the Baldwin Locomotive Works and is of the 4-4-2 type with wide fire box extending over the trailing wheels. The cylinders are 15 and 25x26 inches and the driving wheels are 78 inches diameter. The high pressure cylinders are inside and transmit the power to the forward axle which is cranked and the low pressure cylinders drive the back pair of driving wheels. This arrangement has been worked out admirably by slightly elongating the piston rods of the low pressure cylinders. One set of piston valves distributes the steam to two cylinders—high and low pressure.

It seems very desirable in a four cylinder balanced engine that only one pair of cylinders should transmit the power to one pair of driving wheels. In this engine the division of power has been carried out, while keeping the mechan-

ism so convenient that every moving part and bearing can be readily seen and reached. The advantages claimed for the de Glehn type of locomotive are obtained without placing a pair of cylinders back outside the frames where securing with proper rigidity is almost impracticable.

One bright day towards the end of September I found engine 2700 on the front of a long train of passenger cars getting ready to start with the 1 P. M. train. The engineer, Mr. J. P. Murphy, one of the brightest of his class, was oiling round and giving the engine final affectionate attention. In the few minutes' talk I had with him he expressed the warmest kind of admiration for the engine, saying that he had handled many good ones but never any of them touched the 2700.

The pull out of St. Louis is extremely hard, round various sharp curves and up to an elevated structure, that carries the railroad over the city streets. As I looked back and counted the cars in the train, I found that there were fifteen of them, three being sleepers and all heavily loaded. Yet the engine started that train which weighed over 650 tons with scarcely a slip and within a mile had reached a speed of thirty miles an hour. A particularly noticeable thing about the performance was the entire absence of knocking so common when engines working hard pushing into speed are turning over the centers. This, of course, was due in a great measure to the engine having eight centers to pass during each revolution of the wheel instead of the ordinary four, and it accounts for such engines being particularly light on repairs.

The run from St. Louis to Hannibal, 120 miles, is up the Mississippi Valley and the track, which follows the river bank a considerable part of the way, is fairly level. For the first twenty miles of the way nothing unusual was done, the running speed having been about 50 miles an hour. But after we left West Alton, Engineer Murphy seemed bent on making up the seven minutes that the train was late in starting. In a very little time we were running along at about 70 miles an hour and I am under the impression that it reached 80 miles an hour, a particularly notable performance with nearly 700 tons behind the tender. A thing that made a man, who had not quite lost the locomotive engineer inspiration, feel good was the way the engine steamed. The steam gauge needle seemed fastened to the 220 pounds' figure, the blowing off point being 225 pounds. Before the train started one of the railroad officials expressed a fear that the engine would not be found at its best, because the fireman, Mr. O. B. Waters, had been on her but a short time. Mr. Waters need-

ed no excuses. I received the impression that he was as good a fireman as I ever watched. He not only kept the engine hot but did the work so judiciously that there was no waste from blowing off and no fluctuation of steam. I also noted that engineer and fireman worked carefully together, a condition of harmony that always promotes the best results in the performance of every locomotive.

While carefully watching the little drama in the cab with first class actors doing their best, we were speeding along with such success that 48 miles were run over in 45 minutes, which included one slow down to catch orders and a three minute stop to pick up a sick fireman. The 48 miles were run in 40 minutes, an average of 72 miles an hour. While putting the heavy train at this high velocity the engine rode as smoothly as a parlor car and there was entire absence of the hammer-like blows that seem always to strike upwards at very high speed producing a succession of uncomfortable jars.

We made several stops in the run of 120 miles. I had never before seen such running made when the engineer failed to jump down and feel the bearings when the opportunity came, but Mr. Murphy did not leave the cab. Said it was no use, the engine would go through in as good shape as when the train started and she did. It is needless to add that the train reached Hannibal on time.

An official connected with the Atchison, Topeka & Santa Fe Railway at Fort Madison told me that they have a group of Baldwin balanced compounds there which are making a most enviable record. Their excellent riding qualities make them popular with the enginemen, the engines are the most sparing on the coal pile of any locomotives doing similar work and they are remarkably light on repairs.

These lines seem to constitute a high testimonial of good character but they are a faithful record of the words told to me.

High Steam Pressure and Superheating Produce Wonderful Results.

Ever since the steam engine came into use many of the brightest minds of the world have devoted intense labor and far grasping thought to the working out of improvements that would increase the efficiency of the engine as a prime mover. Originally there was great waste of heat between the burning of the fuel and the exhaust of the steam from the cylinder, but great improvements have been effected although the steam engine is yet very wasteful of heat, since in most engines little more than ten per cent. of the potential energy in the fuel used is converted into work. That, however, is much more than what was utilized for many years.

One pound of coal evaporates about ten pounds of water and one and a quarter pounds of coal generating sufficient steam for one horse power per hour is considered an extraordinary performance. One pound of good coal is reckoned to produce about 14,500 thermal units, each of which, according to the science of thermodynamics, is equal to 778.3 foot-pounds of work. Therefore, $14,500 \times 778.3 = 11,285,350$ foot pounds, or about 5.7 horse power per hour.

We have been accustomed to regard the perfected classes of marine engines with quadruple cylinders exhausting into condensers as the most economical converters of steam into work, but we have recently seen reports of the performance of steam automobile engines which produce the horse power unit on less steam than anything recorded of the most efficient marine engines, and that with an engine exhausting into the atmospheric heater. About the highest efficiency claimed for the quadruple expansion condensing marine engine is about $1\frac{1}{4}$ pounds of coal per horse power per hour representing about 13 pounds of steam. Figured from the total energy in the coal, the efficiency of such a marine engine is .175, being far above the average.

The performance of the automobile steam engine which we refer to, was recorded by Professor C. B. Benjamin, of Case School of Applied Science. He made exhaustive tests of the engines of a White automobile and reported that work was done on a steam consumption varying from 10.8 to 14 pounds per indicated horse power. The engine was very small, being a compound with cylinders 3 and 5 inches diameter and $3\frac{1}{2}$ inches stroke. The small size of the engine makes the phenomenally economical consumption of steam all the more extraordinary. There were eight tests made, the average steam pressure in the boiler being 329.75 pounds and the average steam temperature in the engine 710 degrees F. The White automobile uses a flash boiler which accounts for the very high steam pressure and temperature. The high degree of superheat in the steam accounts for the small volume used.

The performance is so extraordinary that it unsettles our preconceived notion of steam engine economy. The high standing of the gentleman who made the tests precludes any suspicion of deception; but we should like to receive the record of more tests before we accept without doubting the new teaching that a very small engine can be made to work more economically than a large one equipped with the most approved appliances for economical operation.

That which we are we shall teach, not voluntarily but involuntarily.—Emerson.

Westinghouse Awards at the St. Louis Exposition.

The Westinghouse Electric and Manufacturing Company have received an award for "alternating current generators and motors, alternating current turbo-generator installation, static transformers, and rotary converters," also one for "direct current generators and motors," and one for "electric railway motors, alternating current and direct current, and control systems for single and multiple unit operation and for mining and industrial locomotives"—all in Group 67.

The Westinghouse Machine Company were the recipients of an award for "Horizontal gas engines and steam turbines"—Groups 62 and 63.

The Westinghouse Air Brake Company were given an award for "Air brakes and friction draw gears." and the Westinghouse Traction Brake Company one for "Brakes for electric cars." The American Brake Company, one for "Driver brakes." The Westinghouse Automatic Air and Steam Coupler Company, one for "Air and steam couplers." The Westinghouse Brake Company, Limited, London, England, one for "Air brakes and accessories." The Westinghouse Company, Limited, of St. Petersburg, Russia, one for "Air brakes and accessories." The Union Switch & Signal Company, one for "Signal system"—all these are in Group 74.

The Cooper Hewitt Electric Company received an award for "The development of the mercury vapor arc lamp"—Group 69.

Gold medals were awarded as follows: one to the Westinghouse Electric and Manufacturing Company for "Complete switchboards and controlling apparatus, and the application of electric motors for mechanical purposes" in Group 67; also another for "Alternating current, direct current, and Bremer arc lamps and arc lighting systems" in Group 69; another for "Electric measuring instruments" in Group 71. One was given to the Westinghouse Air Brake Company for "The housing of the working classes" in Group 136.

The Nernst Lamp Company, one for "Nernst lamps"—Group 69; one to the Cooper Hewitt Electric Company for "Vapor lamps for photo-engraving" in Group 15; one to the Pittsburg Meter Company, for "Water and gas meters" in Group 64. And another for "Industrial betterment work" in Group 138.

Four silver medals were awarded, one to the Westinghouse Electric and Manufacturing Company for "Switches, fuses and wiring appliances" in Group 69; also one to the Sawyer-Man Electric Company for "Incandescent lamps" in Group 69; another to the Bryant Electric Company, for "Electric light fittings" in Group 60; and the fourth to the Société An-

nyme Westinghouse, Havre, France, for "Gasoline Automobiles" in Group 72.

One bronze medal was awarded to the Perkins Electric Switch Manufacturing Company for "Electric switches" in Group 60.

The General Manager Thinks Hard—Very Hard.

That the General Manager was not quite himself that morning was evident the moment he entered the office. His usual calm, dignified solidity had given way to a nervous, absent mindedness of manner, so entirely foreign to the steady-going man, that even Phil, the office boy, observed it, and remarked upon it with all the precociousness of youth.

"Hully Chee," he said, "de boss is bug-house, fer fair, dis mornin'. Why, he nearly knocked out me lamps when he t'rowed me his dicer and eane fer de hat rack."

Burns, the head clerk, also observed the change in his chief. He followed him through the green, swinging door to the inner office where the "referred" mail had been taken as usual for that official's personal attention. This morning, however, the General Manager did not immediately plunge into the correspondence, as was his usual custom, but left it untouched, and, after lighting a cigar, paced the room, puffing dense clouds of smoke at each step.

Burns coughed a bit to delicately announce his presence; but it was to no purpose, for the General Manager continued his pacing and puffing.

"He's thinking hard—very hard," said Burns to himself. "Guess I'd better leave him alone," so withdrew, softly.

Phil's eye had curiously sought the crack of the green, swinging door, and

"That'll do you, kid," said Burns sharply, coming out through the green, swinging door; "cut it out!"

Phil took the rebuke meekly, and quickly resumed his copying work at the letter press. So quiet was he for a moment that Burns was almost ready to accuse the boy of thinking hard.

"Br-r-r-r," sounded the electric buzzer at Burns' desk. It was the General Manager's call—one of those hurry up-I want-you-quick kind of calls.

Manager's inner office. "The boss" had resumed pacing and puffing, and was evidently thinking hard. He turned suddenly, and said:

"Anderson, did you appoint that air brake man—Jennings—or whatever his name is?"

"Well er-er," hesitated the General Superintendent, calling quickly into exercise that premier requisite of railroad diplomacy, technically known as "shifting the responsibility," and more or less

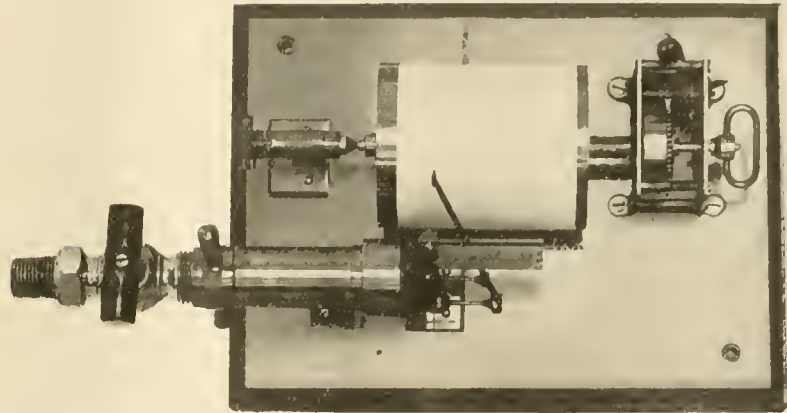

INDICATOR MACHINE FOR TAKING CARDS OF BRAKE CYLINDER PRESSURES.
(TOP VIEW.)

Burns pushed through the green, swinging door and faced the General Manager, who was still pacing the floor and blowing clouds of smoke. "Haven't we an air brake man on this road?" asked the General Manager. "I mean one who supervises all air brake matters, and is responsible for them. Didn't we appoint such a man some time ago?"

"Yes, sir—two years ago. Jennings is his name—T. L. Jennings. I'll get his appointment circular, sir," said Burns, making a move toward the green, swinging door.

used by shrewd persons. "I didn't exactly appoint him. I guess I approved his appointment, after it had been made by Jones, the Division Superintendent, or Burke, the Superintendent of Motive Power, I don't know which."

The General Manager ordered Burns to produce Messrs. Jones and Burke, and both made their appearance without delay.

"Yes, sir, I believe I appointed Jennings," replied Jones in response to the General Manager's question. "That is, I believe I appointed him after Mr. Burke recommended him. I thought we ought to have an air brake man, as all the other roads were getting one, and we couldn't afford to be behind. So I asked Mr. Burke to recommend a man. He recommended Jennings, and I guess I must have appointed him."

"Well, it's up to you two, anyhow," replied the General Manager. "I wish I had him here; is he anywhere about?"

Mr. Burke advised that he had left Jennings in the outside office, waiting to get a pass for his sister to New York. Burns was again called and ordered to produce Jennings.

"What does the General Manager want of me?" asked Jennings in surprise. "He never saw me, and wouldn't know me from Adam's off ox."

"He wants to give youse yer bumps," whispered Phil, mischievously.

"I don't know what he wants," replied Burns. "He's been thinking hard all morning." Then adding facetiously, "But I hardly think it's to give you a

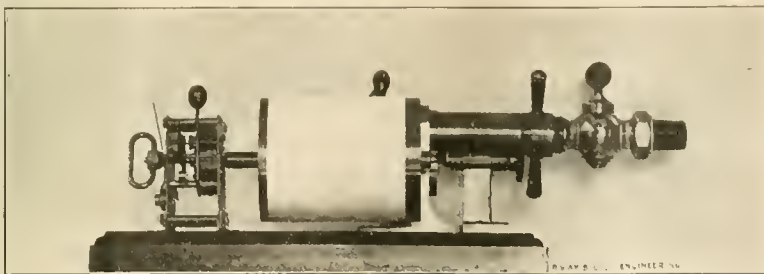

INDICATOR MACHINE FOR TAKING CARDS OF BRAKE CYLINDER PRESSURES.
(SIDE VIEW.)

quickly took in one important feature of the situation. "The boss" was infringing office rules. The almost sacred and rigorously enforced rule, "No smoking," was being fractured into numerous chunks by "the boss," the most rigid of disciplinarians. Phil was quick to take boyish advantage of the situation and was parading the outer office with a cigarette in his lips, cocked at a sharp angle upwards, taking a "dry smoke."

"Not necessary. Don't bother," quickly spoke the General Manager. "Who appointed him?"

"The General Superintendent, Mr. Anderson, I believe, sir."

"Call Mr. Anderson—tell him I wish to see him at once," jerked the General Manager, nervously.

Mr. Anderson responded to Burns' telephone message and passed through the green, swinging door to the General

two weeks' vacation at the World's Fair at the company's expense, or a fat expense account. Maybe he wants to look you over before giving you a raise. Who knows? But come on in, and take your medicine."

Burns led the way through the green, swinging door, carrying in his hand the

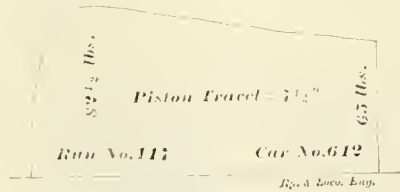

(Jennings called the attention of the group in the General Manager's office to this card.)

**QUICK ACTION APPLICATION STOP,
110 LBS. TRAIN LINE PRESSURE.**

The highest, or initial, pressure of this brake cylinder card is 82½ lbs., producing a maximum braking power of 124 per cent., and the lower, or terminal, pressure is 65 lbs., giving a braking power of 96 per cent., the braking power reducing during the stop from 124 per cent. to 96 per cent., thus supplying a differential in braking power of 28 per cent. during the stop.

circular announcement of Jennings' appointment.

The sight Jennings saw upon entering will probably be remembered as long as he lives. There sat the General Manager, leaning back in his office chair, looking across his flat-topped desk toward the green, swinging door. Messrs. Anderson, Jones and Burke all sat in a line along the side of the desk at the General Manager's right, in the big, leather-cushioned arm chairs, which they all would have gladly exchanged at that moment for a seat box on a locomotive or in a freight caboose. The light from the two large windows, back of the General Manager's chair, fell fairly on their faces, which showed that the luxury of the big, leather upholstered chairs at that moment was entirely lost upon these individuals. This light struck Jennings full in the face as Burns led him up to the desk, opposite to the General Manager. "This is Mr. Jennings, sir," said Burns, and laying the circular on the desk before the General Manager, "this is his announcement circular."

The General Manager picked it up and read:

THE GREAT MIDLAND RAILROAD.
Chicago, Ill., September 4, 1902.

Mr. T. L. Jennings is hereby appointed General Air Brake Inspector of this system, to take effect this date.

(Signed) R. L. ANDERSON,

Approved Gen'l Supt.

H. H. ALEXANDER,
Gen'l Mgr.

"Why, Anderson, you and I appointed Jennings!" exclaimed the General Manager.

"Y-yes, sir," stammered the General Superintendent, a trifle abashed. Messrs. Jones and Burke breathed more freely,

and Mr. Anderson prepared himself for a hard drop.

"Well, it doesn't matter much, just yet," said the General Manager, looking up at Jennings, who was decidedly confused and frightened.

"Mr. Jennings," said he, somewhat sternly, I came west on No. 7 this morning. At Centreville I went forward from my private car on the rear of the train, leaving my wife and daughter preparing for breakfast. I passed through four Pullman sleeping cars and stepped into the dining car. No sooner had I got in than the dining car began to jerk and pull. The car ahead seemed to be in distress. Suddenly the dining car began to plunge and roll and dishes were thrown crashing from the tables and pantry. The car was filled with women and children. They became panic stricken. They huddled together in the aisle and screamed. They were tossed this way and that. They were clutching at everything and at each other. No one could keep their feet. I was thrown against

and above all, the thought went rushing through my brain: 'Why don't those air brakes stop this train?' The situation grew worse. The dining car plunged and rolled like a little Lake Michigan boat in a storm. It tossed like a cork. It darted sidewise like a runaway automobile. It did everything horrible. If ever passengers faced death, those in that car did."

"That's no lie," interrupted Jennings. "That was the narrowest escape No. 7 ever had."

"How do you know?" asked the General Manager, looking up.

"Pardon me, sir, I did not mean to interrupt you, or to talk just that way," apologized Jennings, very meekly. "I was on the train. I had been riding on the engine, and had just gone back to the dining car to get some breakfast, when the accident happened."

A gasp of surprise escaped from the three officials lined up on the right of the General Manager's desk. They had heard of the accident, but did not

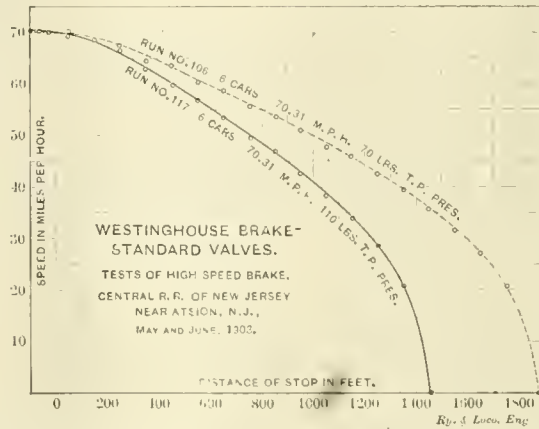

(Another card which the group discussed in the General Manager's office.)

WESTINGHOUSE, QUICK ACTION APPLICATION STOPS.

This diagram shows the superiority of the high speed brake over the 70 lbs. brake, a betterment of about 450 feet in favor of the former in stops from speeds of 70 miles per hour.

a window, which was shattered. The sound of the broken glass added to the din of broken dishes. From the grinding of the car underneath I realized that we were off the track. The river, about thirty feet below on the right side, seemed to look up to us, dark and terrible. On our left, the hill above frowned down and threatened to fall on top of us. Everything looked fiercely threatening and unfriendly. The brakeman, after several attempts, pulled the conductor's cord, but that did no good. The train kept going. I thought it would never stop. I thought of my wife and daughter back in the private car. Gentlemen, I am speaking the truth when I say that I would have given all my possessions on earth and mortgaged my chances on the hereafter to stop that train. I expected every minute that the couplings between the dining car and the car ahead would break, and we would all roll in a heap into the river below. Through it all,

know before that the General Manager and Jennings were in it.

"But, Jennings, why did those brakes fail to work?" asked the General Manager. "It took an eternity to stop that train."

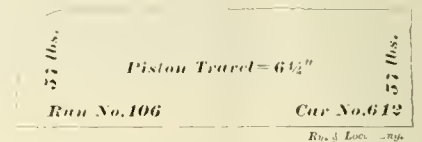

(Another card discussed.)

WESTINGHOUSE, QUICK ACTION APPLICATION STOP, 70 LBS. TRAIN LINE PRESSURE.

This brake cylinder pressure card shows both the initial and terminal pressure to be 57 lbs., or an average of 57 lbs. pressure during the stop.

"The brakes didn't fail, sir," replied Jennings. "They worked just as well as usual. We can't expect to stop our trains as quick with our ordinary brakes as some of the other roads can with their

high speed brakes. The stop, maybe, seemed longer to you, as you were in the midst of the accident, and your lady folks were also on the train."

"Do you mean that we haven't as good brakes as our neighbors and competitors?" quickly retorted the General Manager.

"Our brakes, sir," interrupted Mr. Burke quietly, "are as good as the brakes on any other road, so far as conditions go, but they are not as modern and powerful as some of the other roads have."

"Why is that? Do you mean to say that the Midland is behind its neighbors and competitors?"

"I am sorry to say it is, sir, in respect to brakes," replied Burke.

"Do you—you, the Superintendent of Motive Power of this great line—this great Midland Railroad—you, to whom our motive power is intrusted, do you admit, right here, that you have neglected your business—that you have allowed competing lines to have better air brakes than we have?"

"No, sir," replied Burke, just a bit disconcerted, for the General Manager's eyes were shining now. "I have not been neglectful, sir; I have had high speed brakes specified on each month's order for material, but somehow they never come."

The General Manager stared for a moment, then looked at the General Superintendent and asked, "How is that, Mr. Anderson?"

"It is just as Mr. Burke says," replied Mr. Anderson. "High speed brakes are ordered each month. The requisition passes through my hands all right, but the brakes are cancelled somewhere above my office."

The General Manager stared for a moment at the three in the leather cushioned chairs, then at Jennings, still standing before him. "I wonder," said the General Manager, "passing his hand reflectively across his brow into his hair, "I wonder—"

"Br-r-r-r" went Burns' buzzer, and he again passed inward through the green, swinging door.

"Burns," said the General Manager, thinking hard, "bring me last month's requisition sheet."

It was laid before him in a moment and the General Manager scrutinized it carefully.

"High speed brakes—high speed brakes," he mused, audibly. "Ah, here it is—high speed brakes. But there is a red line drawn through this item. Why is that, Burns? Who did that?"

"That is your order, sir," replied Burns. "You did that to complete the 25 per cent. cut in supply material the first of the year. We've had to economize, sir.

(Continued on page 527.)

Electric Locomotive for the P. & R.

The Philadelphia & Reading Railway have recently purchased from the Baldwin Locomotive Works an electric locomotive which has been named "Reading No. 1."

This locomotive is intended for the haulage of freight on the Cape May, Delaware Bay & Sewell's Point Railroad, which is a small road controlled by the Philadelphia & Reading. The machine is mounted on two trucks, and has a motor on every axle. The driving wheels are 30 ins. in diameter, and the total weight of the whole is 40,000 lbs. The starting draw bar pull on the level with clean dry rails is 8,000 lbs. The full load speed is about 10 miles per hour, and the full load draw bar pull when running is about 6,000 lbs.

The equipment consists of four 500 volt Westinghouse 38-B street railway motors of 50 h.p. each. There is one Westinghouse K-14 magnetic blowout

punching and shearing machinery. The catalogue is well illustrated and contains 100 pages, and there is in it practically all the types of machines of this class which are made. The book opens with a copious index, and this is followed by a series of illustrations and descriptions of the various kinds of machines made from the bloom and billet—steam driven shears to the machines for punching tender plates with automatic and hand spacing tables. There are also riveting machines and wheel riveting machines, armature disk notching machines, punch and shears with cranes, horizontal punch and bender capable of bending the ends of 24 in. I beams, beam coping machines, plate splitting machines, horizontal bending or forming machines, heavy drop hammers, adjustable cushioned helve hammers, bending rolls, side grinding machines and many others. Write to the company if you would like a copy of this most interest-



ELECTRIC LOCOMOTIVE FOR C. M. D. B. & S. P. RAILWAY.

controller, and the cab is fitted with electric heaters. The Westinghouse automatic air brake is used. Air sanders are also in evidence. The length of the frame over all is 23 ft. Each truck has a 6 ft. base, while the total wheel base is 18 ft. The width of the locomotive is 9 ft.

Standard M. C. B. car couplings are used, but as will be seen from our illustration, a pair of street car couplings have also been supplied, for the shifting of trolley cars, if such becomes necessary. The locomotive draws its current from an overhead wire, which is suspended alongside of and not directly over the center of the track. The height of the engine to the top of the cab is 11 ft., and the total weight is 47,000 lbs.

The Long & Allstatter Company, of Hamilton, Ohio, have just issued catalogue No. 20, dated October, 1904, and it is devoted to the consideration of

ing catalogue or are in any way interested in the subject.

Nearly all young enginemen are ambitious to learn all they can about valve motion, for to talk intelligently on that subject implies the possession of useful knowledge. To the men willing to study valve motion we would cordially recommend "Locomotive Link Motion," by F. A. Halsey. It costs only one dollar and tells the whole story.

The people of Portland, Oregon, are preparing to hold a world's fair next year. The world's fair is a line of money making that is a little overdone. It makes us melancholy to think that a sense of duty might call us to another exhibition within a year.

Don't do what you are sure to be sorry for.—Our Mutual Friend.

A Cheap Shop Crane.

The Southern Railway shop people at Atlanta, Ga., have made for themselves a crane which is suitable for use in machine or smith shops. It may almost be said to be composed of scrap material.

To begin with, an old car wheel embedded in the ground forms the base or foundation, and the opening for the axle is used to receive the end of the upright post, and the post being fitted with a collar revolves easily upon the hub of the wheel. The post is a length of pipe 4 ins. in diameter, standing 19 ft. 3 ins. above the floor line. Roller bearings are provided in a suitable cap at the top. The jib is a piece of timber 2 ins. wide and 15 ins. deep. This jib is made either 18 or 20 ft. long, as required, and stands with upper surface 12 ft. 9 ins. above the floor. It is securely bolted to two plates, which pass on either side of the upright post, and which plates are held up by a stout bolt which passes through the 4 in. pipe post. The timber

ent. Mr. E. P. Bryan, vice-president of the company, and Mr. Frank Hedley, general manager, acted as hosts on this most notable occasion, and everything went off without a hitch of any kind.

The road at present begins at the city hall, and a loop at that point takes the road under Mail street, so that the Brooklyn Bridge station is practically the first station on the uptown line. The road runs up under Elm street and La Fayette place to 4th avenue, which it follows to 42d street, where the road curves to the left through a right angle and tunnels under 42d street to Broadway, up which it passes at present to 145th street. The run from the Brooklyn Bridge station to 96th street, a distance by the tunnel of about 7 miles, was done without a stop in 10 $\frac{3}{4}$ minutes. The total time to 145th street was made in 17 minutes.

There are four tracks from the City Hall to 96th street, at which point two are graded down and pass along under

illuminate the tunnel there is no direct light thrown into the eyes of a motor-man on an approaching train. The block and interlocking signal system is of the latest type, which will be more fully dealt with in a subsequent issue of our paper.

When it is considered that this immense system, the largest of its kind in the world, has to be in full operation every day within one hour and thirty minutes after the departure of the first train, and in the rush hours carrying thousands of passengers promptly and safely to their destinations, one can best appreciate the enormity of this great undertaking and form some idea of the great advance which has been made in the whole science of transportation, and which has been marked by the opening of the New York Subway.

We have received from the Smooth-On Manufacturing Company, of Jersey City, a new illustrated catalogue showing the different products of that concern. The first is smooth-on elastic cement. This is a metallic elastic cement for inside seams of marine and stationary boilers and is applied with a brush. Smooth-on joints is a silicated iron cement for connecting ball-and-spigot cast iron pipe in place of caulking lead, or may be used in combination with it. Smooth-On cement packing is a combination of smooth-on iron-cement and rubber, intended to withstand high temperatures and pressures. Smooth-On Scale is an anti-scale preparation for the prevention and removal of scale in steam boilers. Smooth-On Castings is an iron cement for repairing blemishes, blow-holes or defects in iron castings or steel, and Smooth-On compound is an iron cement for repairing leaks or making connections in steam or hydraulic work. Each of these forms of the product of this company is illustrated and the method of application of each is described. If you are interested in this matter write to the company and they will be happy to forward a copy of the illustrated catalogue.

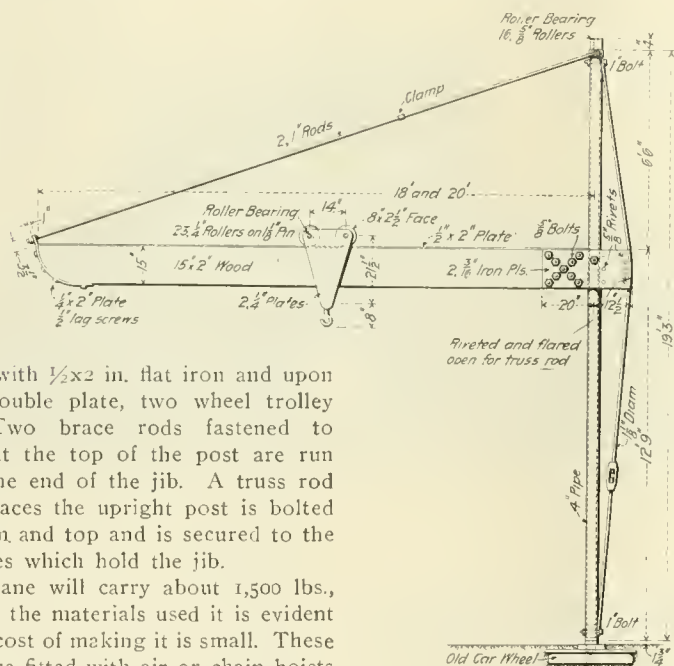

A CHEAP SHOP CRANE.

is faced with $\frac{1}{2} \times 2$ in. flat iron and upon this a double plate, two wheel trolley runs. Two brace rods fastened to clamps at the top of the post are run out to the end of the jib. A truss rod which braces the upright post is bolted at bottom, and top and is secured to the two plates which hold the jib.

The crane will carry about 1,500 lbs., and from the materials used it is evident that the cost of making it is small. These cranes are fitted with air or chain hoists and cover a circular area whose diameter may be 36 or 40 ft.

The Subway Division of the Interborough.

Some time before the opening of the Subway Division of the Interborough Rapid Transit Company in New York City, on October 3, to be exact, a special trip was given to the press representatives, both daily and technical, and a record run was made. A special train consisting of six cars was used on this occasion. The first and last cars were of the all-steel type which has lately been introduced on this road, and the four other cars were the copper sheeted type which had been in service for some time on the elevated division. About a hundred and fifty press representatives were pres-

ent. Mr. E. P. Bryan, vice-president of the company, and Mr. Frank Hedley, general manager, acted as hosts on this most notable occasion, and everything went off without a hitch of any kind.

104th street at a depth of 60 or 70 feet below the surface. The tunnel enters Central Park below 104th street and 8th avenue, and is driven diagonally under the park and again turns north on the east side at Lenox avenue, under which street it passes up to 141st street, where it curves to the right, and at 145th street, where the company's repair shops are located, the tunnel comes up into the sunlight, close to the Harlem river.

There are about 15 miles of tunnel comprised in the present subway division of the Interborough; most of it is from 8 to 10 or 12 ft. below the surface. It is lighted throughout by incandescent electric lights which are arranged on the posts in such a way that though they il-

The Crandall Packing Company, whose New York office is at 123 Liberty street, have issued a small folder which sets forth the merits of their locomotive air-pump and throttle-stem packing, and gives all kinds of information concerning the same. The Crandall Packing Company admit that on railroads the strenuous life is the only one possible, and they are also satisfied that this strenuousness extends to the service required of packing which is intended to withstand the heavy pressures and consequent high temperatures of the present day. They, therefore, invite an examination of their goods and are willing to send the folder to any address on application being made to them.

An effort was made lately by Chief of Transportation Smith of the St. Louis Exposition to bring together representatives of the railway clubs in the offices of the Transportation Building but it was not much of a success. The only one well represented was the Iowa Railway Club of Des Moines. President Wagner, of that club, delivered an interesting address in which he told that their club was noted for its democratic character for it was common to hear trackmen, brakemen and general managers taking part in discussions of subjects on which they could all throw light. Mr. Wagner said that he had brought all his family to visit the Fair and he considered that it would prove a valuable educational experience for the young people.

Some interesting facts are given by Mr. D. B. Mason, U. S. Vice-Consul at Berlin, concerning the use of superheated steam in locomotives in Germany. A record of the performance of a simple engine fitted with a superheater and of two similar compound engines using steam in the ordinary way, was kept and it was found that the engine with the superheater saved 10.9 per cent. of coal, and 25.8 per cent. of water. It also developed in the tests made with these three engines that the one using the superheated steam made quicker starts than the compounds, and it made better time climbing a steep grade. The conclusion drawn in this case is that even if there had been no economy in fuel, the fact that the compound engine can be surpassed in performance by a simple engine fitted with superheater, giving increased power and lower boiler pressure is enough to justify the use of the superheater.

The Allis-Chalmers Company, of Chicago, have issued an exceedingly artistic pamphlet which they call the Book of the Four Powers, in which are briefly set forth the scope of that company's manufactures. The four powers alluded to are, of course, steam, water, gas and electricity, and the engines using steam power are typified by the Allis-Chalmers instalment at the St. Louis Exposition, and in the huge power houses of our large cities and big hotels. Water power is first exemplified by the turbine plant at Niagara Falls, then by that at Shawinigan, Canada, and the East Jersey Water Company's pumping stations. Gas is represented by the Nurnberg double-acting four-cycle gas engine, and electricity is shown in the almost numberless uses to which it is now applied. The book throughout is illustrated with excellent half-tones printed each in one of two colors. The book will be sent to any

one who is interested enough to apply to the Allis-Chalmers Company for a copy.

New Patent Head Lathe.

We here illustrate a 16-in. motor driven patent-head lathe, manufactured by the Lodge & Shipley Machine Tool Company, of Cincinnati, Ohio. The motor is a 2 to 1. The patent head shown gives three changes—the two mechanical changes on the driving shaft make six mechanical changes; this, with the 2 to 1 motor, gives a very great range. The simplicity of this arrangement commends it to every mechanic. As regularly made, the controller is operated from the carriage, and not as shown. This lathe can be furnished with a pulley suitably supported in place of the motor, so that the lathe may be operated from the line shaft, with six changes of spindle speed. The claims made for this are especially its mechanical sim-

with a blunt point in the hands of a dentist can strike when driving the gold or amalgam filling home. In the Brown & Sharpe instrument the punch being "sharp" pointed makes a neat and clearly defined "dab." Write to the makers if you would like some more information on the subject.

Mixed by the Composer.

Editors of railway papers have their own share of embarrassment in finding plausible excuses for refusing poetic effusions, but their authors walk the paths of peace compared to the editors of country papers.

Before he began writing character sketches in dialect, Artemus Ward contributed various droll articles to the *Cleveland Plain Dealer*, among which was the following incident in the life of the editor of the *Baldinsville Eagle*:

"Are you the editor?" demanded a ferocious individual with long frizzled

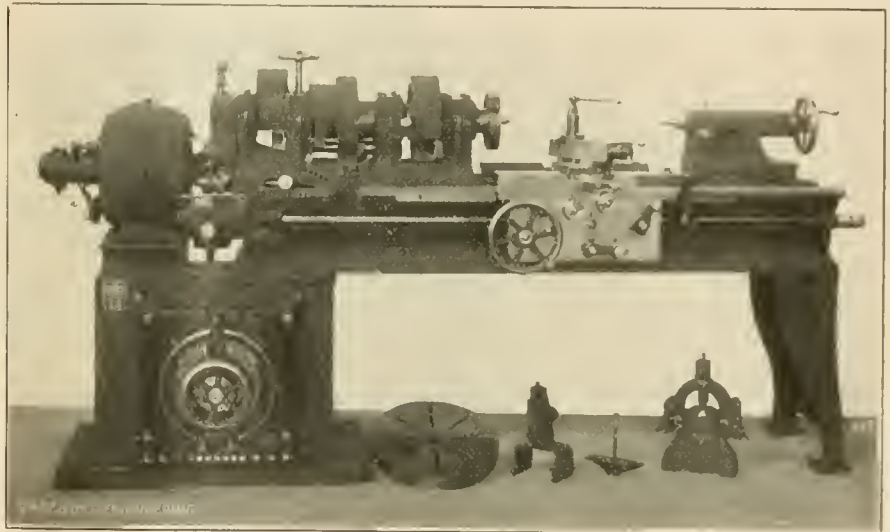

LODGE & SHIPLEY PATENT HEAD MOTOR DRIVEN LATHE.

licity and its neatness of appearance. In this, all the benefits of the Lodge & Shipley recently patented lathe head are contained by which high speeds with heavy cuts, heretofore impossible, are easily obtained.

The Brown & Sharpe Manufacturing Company, of Providence, R. I., have issued a little descriptive circular illustrating their automatic center punch which has been put on the market at \$1.50 each. The advantages claimed for this kind of center punch are that all the punch marks are of uniform depth, and that when a point has been found where it is desired to make a center punch mark the simple downward pressure of the handle releases the striking block and makes an impression. Anyone who has had his teeth filled knows what a sure blow a very similar instrument

hair and a mouth like a baker's oven.

"I am yours truly," replied the editor; "want to subscribe for the *Eagle*?"

"No, I want to know if you can read writing."

"Depends; can read some kinds."

"Read that, then," he said, thrusting at the editor an envelope with an inscription on it.

"B—," said the editor, trying to spell it.

"That's not a 'B'; it's an 'S,'" said the man.

"S? Oh, yes, I see. Well, it looks like 'Sal for Dinner,' or 'Souls of Sinners,'" said the editor.

"No, sir," replied the man; "nothing of the sort. That's my name—Samuel Brunner. I knew you couldn't read. I called to see about that poem of mine you printed the other day entitled 'The Surcease of Sorrow.'"

"I don't remember it," said the editor.

"Of course you don't, because it went into the paper under the villainous title of 'Smearcase To-morrow.'"

"A blunder of the compositor, I suppose."

"Yes, sir; and that's what I want to see you about. The way in which that poem was mutilated was simply scandalous. I haven't slept a night since. It exposed me to derision. People think I am an ass. [The editor coughed.] Let me show you. The first line, when I wrote it, read in this way: 'Lying by a weeping willow, underneath a gentle slope.' That is beautiful and poetic. Now, how did your vile sheet represent it to the public? 'Lying to a weeping widow, I induced her to elope.' Weeping widow, mind you. A widow! Oh, thunder and lightning! this is too much! But look at the fourth verse. That's worse yet. 'Cast thy pearls before swine, and lose them in the dirt.' He makes it read in this fashion: 'Cart thy pills before sunrise, and love them if they hurt.' Now, isn't that a cold-blooded outrage on a man's feelings? I'll leave it to you if it isn't."

"It's hard, sir; very hard," said the editor.

"Then take the fifth verse. In the original manuscript it said, plain as daylight: 'Take away the jingling money; it is only glittering dross.' In its printed form you made me say: 'Take away the tingling honey; put some flies in for the boss.' By George! I feel like attacking somebody with you fire shovel! But, oh! look at the sixth verse. I wrote: 'I'm weary of the tossing of the ocean as it heaves.' When I opened your paper and saw the line transformed into 'I'm wearing out my trousers till they're open at the knees,' I thought that was taking it an inch too far. I fancy I have a right to murder that compositor. Where is he?"

"He's out just now," said the editor. "Come in to-morrow."

"I will," said the poet; "and I shan't forget to bring a stout club along."

There are several good rules which we have no hesitation in recommending to our friends; for instance, the golden rule which, though of great antiquity, still holds its own. Another is the well known rule of three, which, as one might almost say, is one of the pillars of the science of mathematics. There is, however, another rule which though you cannot carry it in your head as you can the other two, yet can be very conveniently carried in your pocket. It is nothing more or less than a very neat little flexible celluloid six-inch rule, got out by George P. Nichols & Brother, Monadnock Building, Chicago, makers of electric drawbridge machinery, transfer tables and electric turntable attachments. This little rule is divided into inches and

fractions down to sixteenths. Write to the firm and get them to send you this rule if you desire to be able to "size up things" correctly.

The Ross Feed-Water Filter.

The function of this feed-water filter is to remove oil from feed water, where water from condensed steam is used over again. This oil separator is used

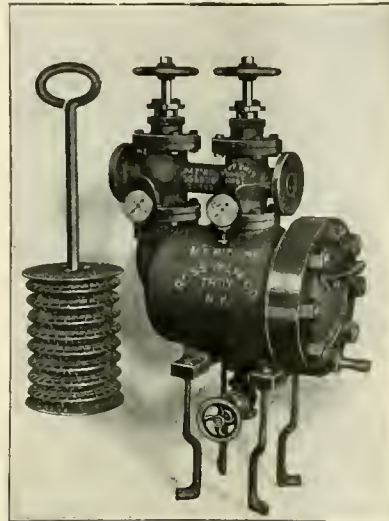

FIG. 1.—FILTER AND EXTERIOR CASE.

on transatlantic and other steamers and is serviceable for stationary engines. In Fig. 1 the exterior and the skeleton of the filter are shown, and Fig. 2 is a sectional view of the same. In this latter illustration the valves of the oil separator are shown open.

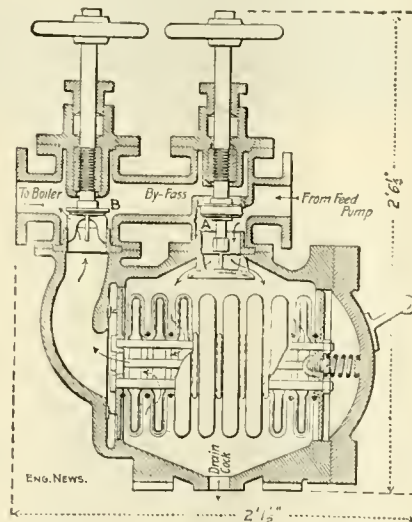

FIG. 2.—ROSS FEED-WATER FILTER.

Water on entering the right-hand pipe passes into the chamber below. In this chamber the filter is placed and is in a horizontal position, practically filling the chamber. The filtering material used is known as Turkish toweling. A section of the filter is shown in Fig. 2, and the filter itself is shown in Fig. 1.

Repairs or Lubrication

A well-known railroad paper recently called attention to this fact: "The locomotive is the only thing on a railroad that actually earns money. If 10% of the locomotives are out of service for any reason, that proportion of the earning power is unavailable. If 20% are in the shops or waiting to get in, the whole system begins to limp."

Poor lubrication will put a locomotive into the shop every time, to reface a cut valve, to rebore a scored cylinder and to reduce rod brasses or to return a cut pin. These repairs cost a road money and don't add any to the engineer's good record.

That's why locomotive engineers took to using

Dixon's Flake Graphite.

It cures many friction troubles, it prevents many friction troubles. It saves engines that would otherwise surely have to be shopped. It saves hundreds of dollars for railroad companies on repairs, tons of coal, gallons of oil, and a great deal of trouble and worry for the engineer.

The engineer is interested in graphite lubrication because better lubrication is a vital point in his work.

To all locomotive engineers we will gladly send a sample of Dixon's Pure Flake Graphite and a copy of our new 52-page booklet, GRAPHITE AS A LUBRICANT.

**JOSEPH DIXON
CRUCIBLE CO.
Jersey City, N. J.**

Please mention LOCOMOTIVE ENGINEERING.

H. S. PETERS' BROOKERHOOD OVERALLS

have gone to almost every part of the World where Overalls are worn and are everywhere conceded to be the **BEST**. Every point of material, cut, construction and finish is carefully looked after; the only way that superiority can be attained. Every garment is absolutely guaranteed. The Patented, Fleece-lined, Safety Watch Pocket is alone worth a whole suit of any other make.

I'll send sample suits, charges paid, to any place in the World where mail or express goes, where I have no retail agency; sample materials and full particulars for the asking.

UNION MADE
OF COURSE —
B.L.F. 3—H.S. PETERS—BLE. 171
DOVER, NEW JERSEY, U. S. A.

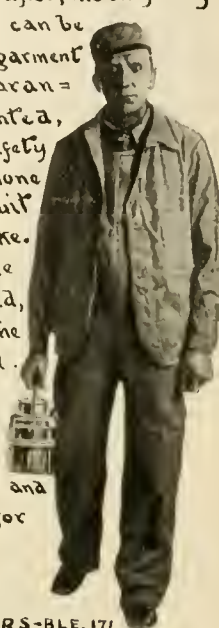

The Twentieth Century Master Mechanic

Won't use solid Mandrels. Cost too much, take up too much room and don't give satisfaction.

Nicholson Expanding Mandrels

Take everything from 1 to 7 inch holes. Take up little room—always ready and you can buy four sets for the cost of one of the solid kind.

Are You Using Them?

Catalogue tells you more about them.

W. H. Nicholson & Co.
Wilkesbarre, Pa.

The filter is made of light circular bronze sections of openwork held together by long bolts. The toweling is made in the form of a bag larger and longer than the skeleton, and it is drawn over the open lattice work and tied between each section so that the whole somewhat resembles a concertina drawn out. The filtering surface thus provided may be made from 250 to 1,000 times the area of the feed pipe as required by the service.

Water introduced into the large chamber passes slowly through the toweling into the inner cavity of the filter and thence to the boiler, while oil and other matter is collected on the outside of the toweling. After a time the accumulation on the outside of the toweling will offer an appreciable resistance to the flow of water, and this resistance will be indicated by the dif-

ference in the readings of the two gauges shown in Fig. 1. When this difference rises as high as 3 lbs., it is time to remove the toweling and wash it or apply a spare piece.

Valve *A*, Fig. 2, has a face on both its upper and lower corners which enables it to seat when in its upper or lower position. If the valve is screwed down the feed water passes direct to the boiler without going through the filter. If the valve *B* is then closed and the drain cock at the bottom be opened the head of the filter may be taken off and the clogged filtering material removed, new material applied and the head put on again, the whole operation takes about five minutes.

There is a method of partly washing out the filter, without disturbing anything. That is accomplished by screwing down valves *A* and *B* and opening the drain cock at the bottom, after which valve *A* is opened and the flow of water thus established washes the outside of the toweling. Shutting valve *A* and opening *B* causes the current of water to flow back and wash the interior of the filter and force its way from within out through the clogged toweling. The handle shown in Fig. 1 is only a handle for convenience in placing it, and can be unscrewed when not required. The filters are tested to 500 lbs. pressure. The Ross Valve Company, of Troy, N. Y., are the makers.

The Landis Bolt Cutter.

The die for this machine, made by the Landis Machine Company, of Waynesboro, Pa., has four chasers. They are made from flat pieces of steel and the teeth forming the threads are milled on their flat sides the entire length of same. The throat of the die is formed by bev-

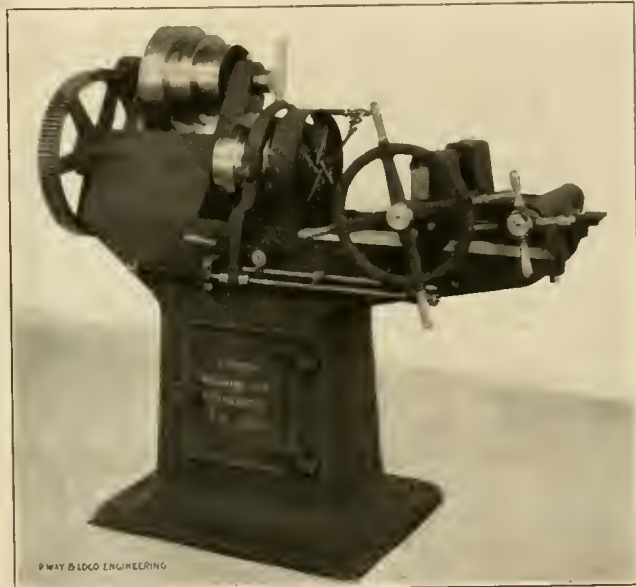

LANDIS BOLT CUTTER.

ference in the readings of the two gauges shown in Fig. 1. When this difference rises as high as 3 lbs., it is time to remove the toweling and wash it or apply a spare piece.

Valve *A*, Fig. 2, has a face on both its upper and lower corners which enables it to seat when in its upper or lower position. If the valve is screwed down the feed water passes direct to the boiler without going through the filter. If the valve *B* is then closed and the drain cock at the bottom be opened the head of the filter may be taken off and the clogged filtering material removed, new material applied and the head put on again, the whole operation takes about five minutes.

There is a method of partly washing out the filter, without disturbing anything. That is accomplished by screwing down valves *A* and *B* and opening the drain cock at the bottom, after which valve *A* is opened and the

flow of water thus established washes the outside of the toweling. Shutting valve *A* and opening *B* causes the current of water to flow back and wash the interior of the filter and force its way from within out through the clogged toweling. The handle shown in Fig. 1 is only a handle for convenience in placing it, and can be unscrewed when not required. The filters are tested to 500 lbs. pressure. The Ross Valve Company, of Troy, N. Y., are the makers.

clinging the edges of the chasers the entire length. This gives uniform shape so that the same results are obtained after each grinding until they are used to their limit, which leaves a very small piece unused.

The cutting and grinding are done on the ends of the chasers. These chasers are held in grooved blocks which are secured by four oscillating spindles, which are geared together in the head and are made to operate simultaneously to open and close the die and to adjust it to proper size. These blocks are interchangeable, fitted neatly to hardened pins, which are pressed in the spindle ends and are secured by screws to their ends which are quickly changed from one size to another.

There is a screw having an annular grooved head, to match the pitch of the chaser, said grooves engage the teeth of the chaser and draw them to a seat in the bottom of the slot as well as press

it against the sides of same, by the angle of the threads on the chaser, making it rigid with the block. The spindles are connected by a central pinion, having a hole through its center, to admit the passage of rods or bolts to be cut. The faces of the teeth on the spindles and pinion are very wide, giving great strength and durability. The central pinion has a wheel secured to it, which engages with a rack seated in a ring encircling the wheel. A screw runs through the rack which can be moved by a key to set the die to the proper size. When the die is closed the links are on a straight line with each other and make a positive lock of the die, without any tension whatever on the sliding or wearing surfaces, thus assuring durability.

The racks, pinion, link and gearing are all inclosed within the head and it is impossible for cutting-scale or grit to get to them. The sliding ring in the head is moved by a yoke engaging segmental blocks by screws, which blocks engage the ring by its groove. This yoke is pivoted to the bed and is arranged for opening and closing the die by hand or automatically by the movements of the carriage. A rod having adjustable stops enables the proper setting for opening and closing the dies when desired.

The carriage is of improved form. The vise has guides centralized over the bolt and securely being held, eliminate side thrust. The rack is central on the machine and immediately below the line of the bolt being cut. The machine is furnished with positive oil pump of rotary type, the oil tank with cuttings pan and screen are located inside the base, both of which can readily be removed for emptying and cleaning. When desired pipe dies will be furnished at the same price as the bolt dies. They can be used on the same heads. The whole machine has been carefully designed with a view to convenience, durability and efficiency.

Mr. A. B. Landis, the patentee of this machine, has spent several years in developing it and has given close attention in connection with the shop work which it is expected to do.

The Falls Hollow Staybolt Company, of Cuyahoga Falls, Ohio, have sent us a little leaflet in which they set forth seven claims for their hollow staybolt iron and they give the explanation for each claim made. In this little folder Dr. Croker, of McGill University, is quoted as saying: "The recovery of over-strained iron and steel is greatly accelerated when exposed to a moderate heat," he mentions a test in which he heated a specimen for four minutes at the temperature of boiling water, "and then tested, with the remarkable result that a practically perfect recov-

ery resulted, accompanied by a greatly raised yield point." The leaflet is well worth reading, and the Falls Hollow Staybolt people will be glad to send you a copy if you write them for one.

"Climax" Regulating Valve.

The "Climax" Regulating Valve has lately been put on the market by the John Davis Company, of Chicago. It is intended for railway train heating service and high pressure work generally. Its action may briefly be described as follows: Steam enters the valve through the Port "A," passing around the valve "B" into the chamber above, forcing "B" open. The steam passes around "B" into the chamber above, marked "F" in our illustration, and escapes through the port "E," down through the channel marked "K" into the low pressure

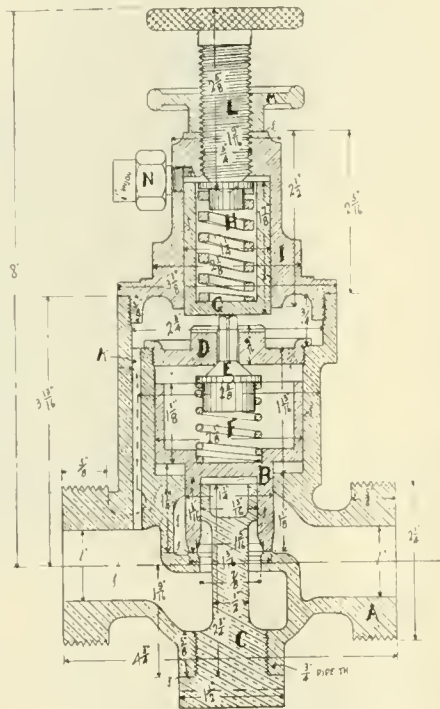

THIS



BOOK

on pumping, air-compressing and condensing machinery is

Given Away

by each of the following companies:

Henry R. Worthington
Laidlaw-Dunn-Gordon-Co.
Blake-Knowles Steam Pump Works
Deane Steam Pump Works
Clayton Air Compressor Works

114-118 Liberty Street, New York

Flexible Spout

Vertically in straight line. Also laterally. The latest Improvement to

Poage Water Columns

American Valve and Meter Company
CINCINNATI, OHIO.

SEND FOR CATALOGUE

steam to pass through the port into the low pressure side until the steam on the low pressure side reaches the point at which the valve is set. This works on the spring "B," closing the valve "E" and again shutting off the valve "B." The piston "C" fits inside of the disk and above the flow of steam, thereby preventing any grit or sediment getting into the dash-pot or pipe. The valve "E" is so constructed that it shuts off the flow of steam gradually, thereby preventing any hammering or chattering in the valve. You can place your ear on the top screw when it is working, and it is almost impossible to hear the valve open and shut. The union "N" is for running a pipe to the air and must be kept open. The condensation which passes by the spring "H" housing is very slight, but it is better to pipe it away than to leave it wide open. This must be left open to the air. This valve has no diaphragm, and there is no liability of it being laid up owing to a broken diaphragm.

Physics.

Charles Kingsley says: "In learning true knowledge we also learn our own ignorance, and the vastness, the complexity, and the mystery of Nature." Now, "Nature" here does not mean simply mountain, river, lake and plain, it means what would be called at college "physics," and this a department of science which is concerned with the properties of natural bodies, and the laws which govern them. It is, in fact, these laws of Nature with which engineers of all kinds have to deal, and in learning true knowledge about such matters we have to accept and study the records of experience which have been given to us by special workers in any particular field of research, and this record of experience is nowadays contained in books. In the particular department of work which embraces railway and also locomotive engineering as well as general engineering we have a stock of selected books to which we invite your attention.

The first on the list is, of course, RAILWAY AND LOCOMOTIVE ENGINEERING, a practical journal of railway motive power and rolling stock. It costs only \$2.00 a year, and is well worth the money, and besides the paper is a welcome visitor in every household. Let your wife and children see it.

"Twentieth Century Locomotives." Angus Sinclair Co., deals comprehensively with the design, construction, repairing and operating of locomotives and railway machinery. First principles are explained. Steam and motive power is dealt with; workshop operations described, valve motion, care and management of

locomotive boilers, operating locomotives, road repairs to engines, blows, pounds in simple and compound engines, how to calculate power, train resistance, resistances on grades, etc. Shop tools explained. Shop receipts, definitions of technical terms, tables, etc. Descriptions and dimensions of the various types of standard locomotives. The book is well and clearly illustrated and is thoroughly up to date in all particulars, fully indexed. Just off the press. Price, \$3.00.

"Locomotive Engine Running and Management," by Angus Sinclair, is an old and universal favorite. A well-known general manager remarked in a meeting of railroad men lately, "I attribute much of my success in life to the inspiration of that book. It was my pocket companion for years." We sell it for \$2.00.

"Practical Shop Talks." Colvin. This is a very helpful book, combining instruction with amusement. It is a particularly useful book to the young mechanic. It has a stimulating effect in inducing him to study his business. The price of it is 50 cents.

"Examination Questions for Promotion." Thompson. This book is used by many master mechanics and traveling engineers in the examination of firemen for promotion and of engineers likely to be hired. It contains in small compass a large amount of information about the locomotive. Convenient pocket size. We cordially recommend this book. The price is 75 cents.

The 1904 Air Brake Catechism. Conger. Convenient size, 202 pages, well illustrated. Up to date information concerning the whole air brake problem, in question and answer form. Instructs on the operation of the Westinghouse and the New York Air Brakes, and has a list of examination questions for enginemen and trainmen. Bound only in cloth. Price, \$1.00.

"Compound Locomotives." Colvin. This book instructs a man so that he will understand the construction and operation of a compound locomotive as well as he now understands a simple engine. Tells all about running, breakdowns and repairs. Convenient pocket size, bound in leather. \$1.00.

"Catechism of the Steam Plant." Hemenway. Contains information that will enable a man to take out a license to run a stationary engine. Tells about boilers, heating surface, horse power, condensers, feed water heaters, air pumps, engines, strength of boilers, testing boiler performances, etc., etc. This is only a partial list of its contents. It is in the question and answer style. 128 pages. Pocket size. 50 cents.

"Care and Management of Locomotive Boilers." Raps. This is a book that ought to be in the hands of every person who is in any way interested in keeping boilers in safe working order. Written by a foreman boilermaker. Also contains

several chapters on oil burning locomotives. Price, 50 cents.

"Locomotive Link Motion." Halsey. Any person who gives a little study to this book ceases to find link motion a puzzle. Explains about valves and valve motion in plain language, easily understood. Price, \$1.00.

"Machine Shop Arithmetic." Colvin and Cheney. This is a book that no person engaged in mechanical occupations can afford to do without. Enables any workman to figure out all the shop and machine problems which are so puzzling for want of a little knowledge. We sell it for 50 cents.

"Firing Locomotives." Sinclair. Treats in any easy way the principles of combustion. While treating on the chemistry of heat and combustion, it is easily understood by every intelligent fireman. The price is 50 cents.

"Skeevers' Object Lessons." Hill. A collection of the famous object lesson stories which appeared in this paper several years ago. They are interesting, laughable, and, best of all, they are of practical value to-day. \$1.00.

"Stories of the Railroad." Hill. Best railroad stories ever written. Those who have not read these stories have missed a great literary treat. \$1.50.

"Standard Train Rules." This is the code of Train Rules prepared by the American Railway Association, for the operating of all trains on single or double track. Used by nearly all railroads. Study of this book would prevent many collisions. Price, 50 cents.

"Mechanical Engineers' Pocket Book." Kent. This book contains 1,100 pages 6x3¼ inches of closely printed minion type, containing mechanical engineering matter. It ought to be in the bookcase of every engineer who takes an interest in engineering questions. We use it constantly as a reference for questions sent to us to be answered. Full of tables and illustrations. Morocco leather, \$5.00.

"Locomotives, Simple, Compound and Electric." Reagan. An excellent book for people interested in any kind of locomotive. It will be found particularly useful to men handling or repairing compound locomotives. It is the real locomotive up to date. \$2.50.

RAILWAY AND LOCOMOTIVE ENGINEERING. Bound volumes. \$3.00.

The L. S. Starrett Company, of Athol, Mass., recently got out a small, white metal badge which is a representation of their trademark. It consists of a pair of outside calipers crossed with the square, the space between them being occupied by a micrometer gauge. This little badge was designed for their salesmen to wear as an appropriate emblem of the firm which makes all kinds of small tools, rules, squares, gauges, saws, calipers, compasses, etc., but there arose

such a demand for it among mechanics, shopmen, hardware men and others that the firm decided to put the little emblem on the market in the form of a pin or watch charm or brooch. They are made of hard, white metal, not plated, but which will not tarnish, and are sold for 15 cents each. The badges are about 7/8 in. wide and are what some people would designate as decidedly "cute." If you want to get a charming little charm write to the Starrett Company and send them 15 cents.

22-Inch Crank Slotting Machine.

The very powerful crank slotting machine here shown is made by the Bement & Niles shops, belonging to the Niles-Bement-Pond Company. The cutter bar is counterbalanced and has the Whitworth drive, with quick return and adjustment for any length or position of stroke. It is provided with spring relief tool apron, having both vertical and horizontal clamping sur-

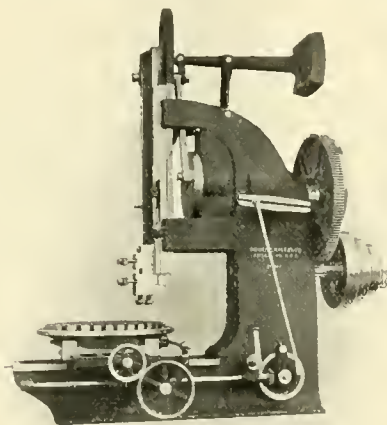

22-INCH CRANK SLOTTING MACHINE.
Niles-Bement-Pond Co.

faces. Directly behind the cutter bar is a reinforcing slide which is adjustable vertically by hand. Maximum stroke, 22 ins. The table is circular, 40 ins. diameter, with pan on circumference for collecting lubricant.

It is provided with hand or power longitudinal feed of 48 ins., cross feed of 41½ ins., also circular feed; all variable and operated by a cam at the upper end of the stroke and controlled from one convenient position. Height of frame above surface of table, 24 ins. Distance from front of tool apron to frame, 36 ins.

The Michigan Central Railroad recently sustained the loss by fire of their roundhouse at Windsor, Ontario. All the engines except two moguls were safely taken out of the burning building. The loss is estimated at \$40,000.

The TAYLOR-NEWBOLD Saw

Cuts easily a .35 carbon forging 9 ins. by 14 ins. in 17 minutes.

Inserted cutters treated by the Taylor-White process under exclusive rights.

30 Cutters in 36 in Saw may be changed in 12 minutes.

A set of cutters hardly dulled in two weeks' continuous cutting night and day.



THE TABOR MFG. CO.

18th and Hamilton Sts.
PHILA., PA.

30-32 South Canal Street
CHICAGO, ILL.

84 Mason Building,
BOSTON, MASS.

49 Deansgate
MANCHESTER, ENG.

Fenwick Freres
PARIS

Schuecardt & Schutte
BERLIN

Patents.

GEO. P. WHITTLESEY

McGILL BUILDING WASHINGTON, D. C.
Terms Reasonable. Pamphlet Sent

The Union Switch & Signal Co.

Consulting and Manufacturing
Signal Engineers.

GENERAL OFFICES AND WORKS AT
SWISSVALE, PA.

DISTRICT OFFICES:

New York: Central Building, 143
Liberty Street.

Chicago: 1536 Monadnock Building.
St. Louis: Terminal Station.

**Keep
Your
Mind
On
It**



**CRANDALL'S HELIOS
AIR PUMP and
THROTTLE VALVE**

PACKING

**Put Up in Sets
Exact Fit to Rod and Box**

Send Trial Order

The Crandall Pkg. Co.

123 Liberty Street
N. Y. CITY

Chicago Office, 30 La Salle St.

FOR SALE

Back numbers of LOCOMOTIVE ENGINEERING from January, 1899, to December, 1903. Bound Volume for 1903. All in first class condition. No reasonable offer refused.

Address BREED.

Care of LOCOMOTIVE ENGINEERING,
136 Liberty Street. NEW YORK

**The General Manager Thinks Hard—
Very Hard.**

(Continued from page 519.)

and that item was cut out to help the general reduction of operating expenses."

"Well—well—well," mused the General Manager, reflectively. After thinking hard for several minutes, he said:

"Well, I guess it is up to me. I'm the guilty fellow. I called you all in to give you a washing out—particularly Jennings—but I guess I'll have to turn the hose on myself. Yes," he continued, "that's one on me."

"Mr. Alexander," said Mr. Burke, regaining confidence, "ten years ago our engines had 18 in. cylinders, carried 160 lbs. steam pressure, and weighed but 40 tons. To-day, our 'Atlantics' have cylinders 20x26 ins., carry 210 lbs. steam pressure, and weigh nearly 100 tons. Then our speed was 40 miles per hour, and now it is 60 and 65. We have the same brakes as ten years ago—no change. So well have they done their work that we

economy, but the air brake part is a poor end to begin on. How much shorter stop would that train have made had it been equipped with high speed brakes, Jennings?"

"I counted eighty rail lengths, sir, from where the broken side rod poked a hole in the ground, to where the back drivers stopped. Allowing 30 ft. to the rail, the stop was made in about 2,400 ft. Judging the speed at 50 miles per hour, which, I think, is a fair estimate, the stop is only fair. But probably the stop was lengthened by the brake rigging on some of the cars being damaged. The dining car and one ahead were both off the track, and this had its effect. The plunging and rocking of the dining car was caused by a gas tank being knocked off by one of the broken-off cab brackets falling under the train."

"Whew," whistled the General Manager. "Imagine a six wheel truck riding on a Pintsch gas tank at forty miles an hour. That's about as safe as riding on a car of dynamite."



(This card told the General Manager something he could scarcely believe).

STOPS MADE TO DETERMINE VALUE OF ENGINE TRUCK BRAKE.

This diagram illustrates two runs with an engine tender and three-car train to determine the value of the engine brake, the speed being about 75 miles per hour. In this stop a betterment of 200 feet was had in favor of the truck brake.

have overlooked them, only giving attention to things that worry and trouble us. The brake still makes good enough stops at stations, but it is inadequate in high speed emergencies."

"You mean," interrupted the General Manager, "that while we have been going ahead in other things, we've been standing still in air brake matters?"

"Exactly, sir," replied Burke. "Our power and equipment have been growing heavier and our speeds higher, but our brakes remain the same, regardless of the fact that brake development has progressed and kept pace with modern railroading. Only we haven't those modern developments."

"We'll get them, and get them quick," asserted the General Manager, positively. "We must, of course, practice

Jennings pulled a January number of RAILWAY AND LOCOMOTIVE ENGINEERING from his pocket, and soon all hands were interested in high speed brake stops. Fifty mile per hour stops were made in 600 ft., 60 mile stops in 1,000 feet, and 70 mile stops in 1,400 ft. Finally, the General Manager spoke.

"I want to say this," he said slowly and deliberately: "I may not have appreciated this air brake situation as I should, perhaps, but I had an object lesson yesterday which has made me think hard—very hard. I want it thoroughly understood from now on that I stand for good brakes—best brakes—'good enough' brakes won't do. We want the best brakes obtainable, and will have them, and have them right away. Herefore we have thought only of heavy

power, good cars and fine roadbed to move trains swiftly. Henceforth, we shall attend more to stopping them. Passengers pay big money to ride fast. What would they pay, in a pinch like I was in yesterday, to stop quickly? I tell you, we have been looking cross-eyed at this thing. It used to be that you couldn't wheel them too fast for me, but since yesterday's experience, you cannot stop them too quickly. When a man's personal pocketbook or his family is concerned, he is liable to think hard—very hard. That's what I've been doing. That's all, gentlemen. Good morning."

The luxurious leather cushioned chairs were emptied so quickly that Jennings was the last to get out through the green, swinging door.

"Did you get your 'bumps,' Jennings?" asked Burns, smiling.

"No, 'the boss' took the 'bumps' himself."

Catalogue No. 100 of the Crane Company, of Chicago, has come to our office. There are 94 pages of illustrations and descriptions of valves of all kinds, pop safety valves for stationary, marine, locomotive and portable boilers, also water relief valves, cylinder relief and snifting valves, hydraulic relief valves, boiler trimmings, globe, angle, straight-way and check valves for standard, medium and high pressures. This company also makes steam gauges, siphons, siphon cocks, water gauges, horizontal and angle check valves, pipe bends, etc., etc. A good index is included in the catalogue. The book may be had by anyone interested enough to write to the Crane Company and ask for a copy. The company have also issued a neat little pamphlet illustrating their exhibit at the Louisiana Purchase Exposition at St. Louis, which they will be happy to send to anyone interested enough to reply.

Under the head of Lubrication of Axles, the Joseph Dixon Crucible Company, of Jersey City, N. J., give, in a little pamphlet, three facts which they consider to be worthy of thought. The first fact is that the smoother the bearing surfaces the easier they will be to lubricate; the second is that all metal surfaces, no matter how they may appear, are full of irregularities, and the third is that Ticonderoga flake graphite is a substance which, when used on a bearing, fills up the microscopic irregularities and makes a very smooth surface. Some further explanation of it is given and some particulars concerning Dixon's Everlasting Graphite Axle Grease. Drop a post card to the Dixon people for a copy of the pamphlet if you are interested.

Circular No. Fourteen is the latest folder issued by the Rand Drill Company, of 128 Broadway, New York, and it deals with Imperial Pneumatic Tools, among which are the "Imperial" hammers, made in seven sizes; the "Imperial" piston air drills; the "Imperial" reversible wood boring machine, and the "Imperial" piston air motor hoist. All are illustrated and the various types of compressors are shown and described. If you would like to get a copy of this circular, write to the company.

Felting was invented by Polynesian savages and brought by the Hawaiian natives to a perfection we have never excelled. They not only make coverings for their houses and blankets out of the felt, but by pounding the inner bark of certain trees succeeded in producing soft and comfortable seamless garments of this material, such as sleeveless coats and cloaks.

The latest feat for the electric current to perform is the extermination of worms and obnoxious forms of life that have a habitat under ground. Brass electrodes are buried in the earth at intervals and a current turned on. No search for the remains is necessary.

The world's railroad mileage at the close of the year 1902 was 520,995 miles, representing an investment of \$34,964,342,000. In the first seven months of this year America exported 350 locomotives, against only 146 for the same period in 1903.

The Northern Pacific has received new tourist cars of the eighteen-section pattern, the largest ever built for an American railway, which have been under construction during the past few months at the Pullman shops, at Chicago.

Exudive Accident.

Mechanical Explanation.—The engineer, seeing a specimen of the Mephitis Americana on the track ahead, hastily applied the air brakes and stopped the train.

But he was not quick enough. The locomotive ran the little animal down.

The conductor went forward hastily. He returned even more hastily.

"What is the matter, conductor?" asked an anxious passenger. "Is anything wrong with the engine?"

"Only temporarily, ma'am," he replied. "It's—er—on a dead scenter."—*Chicago Tribune.*

That is the darkest day in a man's career when he first thinks there is an easier way of getting a dollar than by squarely earning it.—*Horace Greeley.*



Hurry Up with the

GILMAN BROWN

EMERGENCY KNUCKLE

The Trainman's Friend



RAILWAY APPLIANCES COMPANY

Succeeding Q & C CO.

General Offices: Old Colony Bldg.
New York Office: 114 Liberty St.

THE ROBERT W. HUNT & CO.
Bureau of Inspection, Tests and Consultation,
1137 THE ROOKERY, CHICAGO.
66 Broadway, New York. Park Building, Pittsburgh.
31 Norfolk House, London, Eng.

Inspection of Steel Rails, Splice Bars, Railroad Cars, Wheels, Axles, etc. CHEMICAL LABORATORY—Analysis of Ores, Iron, Steel, Oils, Water, etc. PHYSICAL LABORATORY—Test of Metals, Drop and Pulling Test of Couplers, Draw Bars, etc.

Efficiency Tests of Boilers, Engines and Locomotives.

A Thoroughly "Practical" Book

Deals with boiler work of all kinds, from the



**LAYING OUT
OF SHEETS
TO THE
COMPLETED
BOILER**

Best book of its kind.

COMPLETE
MODERN
COMPREHENSIVE

420 Pages. Price, \$3.00

Railway and Locomotive Engineering
ONE MAIDEN LANE NEW YORK

Computers

Train Resistance Computer and Locomotive Tractive-Power Computer

Each Computer is in a neat folding, leather-covered case. One side gives formula and directions for use. The other side has a graduated circle upon which turns a graduated card disc.

Can be Adjusted in a Moment to Give Result Without Calculation

Price, \$1.00 Each

Why Should I?

Ask yourself the question, "Why should I read the SCIENTIFIC AMERICAN?" Because you cannot keep abreast with the world's progress without it. To keep in touch with the great, throbbing life of to-day—industrial and commercial—you must be familiar with the things that are published *only* in the SCIENTIFIC AMERICAN.

The world's progress in science, mechanics, engineering, industry, the latest inventions and discoveries; wireless telegraphy, automobiles, naval progress—in fact everything new to the world appears from week to week in the

Scientific American

Its sharp, accurate, popular articles open the mysteries of science; show how men have made dreams realities; mirror the ingenuity and inventive genius of the American workman; give an outlook on the world of the unknown; and bring the reader in touch with the great inventors of the age.

The subscription price is \$3.00 a year. In addition we offer to *new* subscribers, for a short time only

Scientific American Reference Book FREE With One Year's Subscription.



This Reference Book contains 50,000 facts—accurate, down-to-date, complete. Condensed from great encyclopedias and over a ton of government reports, it is the most reliable and exhaustive book ever published. Anything you want to know, on any subject in any part of the world, can be referred to instantly. Handsomely bound, it will not be sold for less than \$1.50 a copy. Subscribe now to the SCIENTIFIC AMERICAN and get the Reference Book free, and in addition 52 numbers of the brightest, most interesting paper published. Sample sheets of the Reference Book and a copy of the SCIENTIFIC AMERICAN sent on request to any address. Write to-

day. Address Subscription Departments.
Remit \$3.00.

MUNN & CO., Publishers,
355 Broadway, N. Y.

Twentieth Century Locomotives

By ANGUS SINCLAIR COMPANY

It has 670 pages dealing with the designing, constructing, repairing and operating of modern locomotives. Workshop operations, care and management of engines. Quick repairs on the road, shop tools, shop receipts, train resistance and power calculations, definitions and tables. Standard types of engines illustrated and described. Fully indexed. Most all round useful modern compendium of the locomotive. **Price, \$3.00.**

THIS OFFICE.

Entirely New Mortiser.

We here illustrate a machine especially designed and built to supply the demand of railroad and street railway car shops, agricultural implement, wagon and carriage shops, contractors and furniture factories, for a thoroughly reliable hollow chisel mortiser, which is at once easy of adjustment and operation, strong and rigid, and at the same time free from complicated mechanism. It was patented April 5, 1904. It embodies new and important advantages never before presented to the trade, and it is highly recommended where clean cut and accurate mortises are required. This mortiser is designed for chisels up to 1½ ins. square.

The main column is cast in one piece, with broad floor base, making it steady and free from jar or vibration. The upper part is carried on friction rollers, making it easy of adjustment for mortises out of

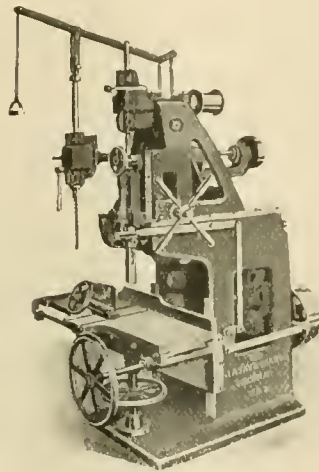

No. III VERTICAL HOLLOW CHISEL MORTISER

line. The pilot wheel for moving the upper column travels back and forth with it, keeping it always in convenient position for the operator. Stops are provided for the transverse movement of the upper column, the extent of which is 11 ins. The chisel ram is mounted in a dovetail slide and has a stroke of 6 ins. It is counterweighted, making it easy of adjustment, and it can be quickly set to the different depths of mortise desired or compensate for thickness of material. The boring spindle in the chisel is driven by miter gears, which permit of belting it from above or directly below the center of the machine.

The feed mechanism is contained in the lower column and gives two speeds to the chisel. The chisel has return stroke of "three to one," accomplished by means of elliptical gears. The feed is controlled by lever within convenient reach of the operator, and is so arranged as to instantly stop the chisel at any point of its stroke. The table, which is mounted on the lower column, forms a take up for all

wear, and is 1x4 ft. It is raised and lowered 12 ins. by means of screws, and has a lateral movement of 18 ins. by means of rack and pinion, and has stops for gauging the length of the mortise. It will accommodate material 17 ins. high and 12 ins. thick. An adjustable clamp is provided for holding any thickness of mortise, and goes clear to the fence.

The auxiliary boring attachments are placed on one or each side of the frame at such a distance from the chisel as will permit of adjusting them to the an angle of 30 degrees in either direction. These are convenient for joint bolt boring, and save much handling of material. The depth of stroke of these boring attachments is 12 ins. and the transverse movement 11 ins.

Further particulars and catalogue of woodworking machinery free on sending a postal card to the makers, J. A. Fay & Egan Co., of No. 445 W. Front street, Cincinnati, Ohio.

Souvenir Spoons.

That the exact extent is not known to which the hotels and railway dining cars are contributing to souvenir spoon collections is attested by the following conversation between two little playmates:

"My mamma has a San Francisco souvenir spoon," boasted the western little girl.

"So's mine," promptly replied the eastern little girl, not to be outdone.

"Mine has a New Orleans spoon," persisted the western little girl.

"So's mine," quickly rejoined the eastern little girl, beaming. Then followed the naming of different cities, without the advantage resting with either of the contestants.

"My mamma has one, yours hasn't," said the eastern little girl, evidently bent on victory. "It's a Waldorf-Astoria spoon from New York."

"That's nothing," rejoined the western little girl, "mine has one, too. And she has an Auditorium spoon from Chicago, and one from the Lehigh Valley, a Black Diamond spoon," she piped triumphantly. "Has yours?"

"N-o-o," reluctantly and hesitatingly replied the eastern little girl, yielding to that terrible broadside.

The controversy was over and supremacy established.

That the B. F. Sturtevant Company, of Boston, who have recently moved to their new office and works at Hyde Park, Mass., are to press the sale of their economizers is evidenced by the new economizer catalogue which they have recently issued. This catalogue contains the details of the Sturtevant Standard and Pony types of economizers, the advantages, sizes, weights, accessibility, repairing, are compared with other makes. It also treats of the subject of

mechanical draft and natural draft, and is of interest to all steam users. It may be obtained by any one interested in the subject on application to the Sturtevant Company.

New Car Coupler.

The McConway & Torley Company, of Pittsburgh, have recently put on the market a new coupler named the "Pitt," having as features a "lock-to-the-lock" and a "lock-set" conforming to the recommended practice of the M. C. B. Association, and having also a "knuckle-opener."

The feature here called the lock-to-the-lock was recommended by the M. C. B. Association two or three years ago, after an investigation by a special committee which developed the fact that with the present day rate of speed and weight of freight trains it is quite possible for the lock of an automatic coupler, not having this special feature, to work upward or creep, and to such an extent can this happen as to frequently cause uncoupling. This feature was applied to the Janney coupler by the McConway & Torley Company before action was taken by the Association, and the inclusion of it in the new coupler simply conforms to past practice and recognizes the fact that such a feature is indispensable in an up-to-date coupler. In principle the lock-to-the-lock as used in the new Pitt coupler is similar to that used successfully in the Janney coupler.

Combined with this is the more recent feature, the lock-set, in favor of which the M. C. B. Association has lately declared. This is an ingenious arrangement by which the lock of the coupler after having been raised to the unlocked position, is sustained in the unlocked position without the necessity of locking up the uncoupling lever by means of a bracket or lock on the end of the car. It allows the knuckle to swing free and to open as the cars part. This device is positive in its action and cannot be shaken down or easily dislodged so as to allow the coupler to relock before the cars separate. This is accomplished by a bell crank-shaped drop forging standing vertically on one arm within the coupler-head back of the tail of the knuckle with the other arm extended horizontally to the right to the locking block or pin. When the locking block or pin is raised to the unlocked position the end of the horizontal arm of this bell crank drops by gravity into a notch in the side of the locking block sustaining it firmly in the unlocked position. It is automatically set for recoupling by the opening of the knuckle as the cars part.

The same member which acts as a lock set, as above described, also acts as a knuckle opener. An upward movement

of the lock beyond the point of unlocking rotates the bell crank, by the engagement of the horizontal arm within the notch of the lock and causes the vertical section to move in a nearly horizontal plane to the right and push the knuckle open. Its action on the knuckle is positive and it pushes the knuckle fully open to the limit of its movement, from either a fully closed position or from any partially open position.

In addition to the above mentioned features the locking mechanism is so arranged that should the coupler break or the draw gear fail, the coupler will not pull out and fall on the track, instead, it will automatically unlock and allow the cars to uncouple, thus removing a very frequent cause of wrecks.

At the annual 'stockholders' meeting of the American Steel Foundries, the outgoing directors were re-elected and Mr. Thomas K. Niedringhaus was elected a director to fill a vacancy, and at a meeting of the Board of Directors of this company held recently the following officers were elected: Mr. Charles Miller, president and chairman of the board; Mr. Geo. B. Leighton, 1st vice-president; Mr. W. D. Sargent, 2d vice-president; Mr. F. E. Patterson, treasurer and secretary; Mr. Max Pam, general counsel. All of those elected had previously held the same offices, except Mr. W. D. Sargent, formerly president of the American Brake Shoe & Foundry Company, who was elected 2d vice-president in charge of manufacturing. An executive committee was also elected consisting of Messrs. Geo. B. Leighton, Edward F. Goltra, W. D. Sargent, E. B. Thomas, Max Pam and Charles Miller.

The fire which recently damaged one of the Fay erecting shops of the great Fay & Egan woodworking machinery plant at Cincinnati, Ohio, will cause no detriment or delay in filling their orders as usual. A large part of the force of men employed in these shops have already resumed work and the remainder have been transferred to the Egan shops and their regular work continued as if nothing of the kind had occurred. Provision for just such a possibility had been made under the business-like system by which this company is handled.

They are constructing a cable traction power on the Argentine Northern Railway, which will extend down the side of the Andes Mountains 32 miles. Its terminal at top will be about 15,000 feet above sea level.

The BARRETT GEARED RATCHET CAR JACKS

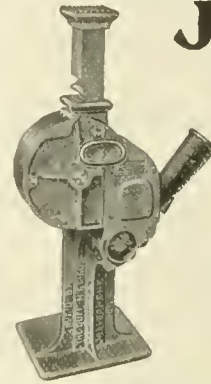

No. 29. 25 Tons Capacity.
No. 30. 35 Tons Capacity.

IMPROVED QUICK ACTING JACKS

for the rapid handling of Empty or Loaded Cars and Coaches and for Locomotives.

Easy to Operate, and they have no intricate parts or complicated features. Have all the simplicity of the ordinary Lever Jack, and are more reliable and better adapted to car work than either Hydraulic or Screw Jacks.

Send for Special Bulletin "L"

MADE ONLY BY

THE DUFF MANUFACTURING CO.

Works: Allegheny, Pa.

PITTSBURG, PA.

FAIRBANKS, MORSE & Co., Chicago,
Agents for Railroad Dept.

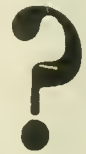

Did it ever occur to you that the reason for the vast passenger business done by the Lake Shore is due to the excellent accommodations which it furnishes?

Unexcelled for travel between Chicago, Toledo, Cleveland, Buffalo, New York, Boston and all points east and west.

Insist on the agent furnishing you a ticket reading over Lake Shore.

You will be pleased with your journey.

Ask for copy of "Book of Trains."

J. SMITH, G. P. and T. A., Cleveland, O.

CONTENTS.

	PAGE.
Air Brake Department.....	505
Balanced Compound, Ride on.....	515
Boiler, Advance in Locomotive, Maintenance	509
Brotherhood Meetings, Increased Interest in.....	497
*Car, Lunch, for Pere Marquette.....	482
Collisions, Prevent Train.....	498
Convention, Traveling Engineers'.....	485
Correspondence, General	489
Correspondence School	501
Editorial	496
Headlights, Electric	504
*Locomotive:—	
Growth of the, By Angus Sinclair.....	484
2-8-0 for Southern Pacific.....	507
4-6-0 for Lehigh Valley.....	495
4-6-2 for Missouri Pacific.....	483
Organization, Power of.....	498
Personals	513
*Rail Loader, Air Operated.....	512
*Railway, Great Indian.....	487
*Shop Appliances:—	
Crane	520
Expanding and Bending Tool.....	494
Stud Extractor	494
*Signals and Signaling, By Geo. S. Hodgins.....	492
Steam Pressure, High.....	516
Steel, Modern Methods of, Making.....	496
*Suds, Extracting Broken.....	490
Train Operation, Overtime in.....	497
Tunnel, Stimpson	481
*Valve Motion, Direct and Indirect.....	500

Railway and Locomotive Engineering

Copyright by Angus Sinclair Co.—1904

A Practical Journal of Railway Motive Power and Rolling Stock

Vol. XVII.

136 Liberty Street, New York, December, 1904

No. 12

High Speed Electric Locomotive for the N. Y. C.

The official exhibition and trial of the powerful high speed electric locomotive, designed and built for the New York Central & Hudson River R. R., by the

York, to Croton, and for 24 miles on the Harlem Division as far as White Plains. It is the intention to handle all the traffic within this district or zone electrically and the locomotive just given trial is one of thirty to fifty which will

weight of train with no complication in operation and with uniform make-up of train crew. A single electric locomotive will be able to maintain the schedule with a 450 ton train, two locomotives being coupled together for heavier trains.



ELECTRIC LOCOMOTIVE AND TRAIN FOR SUBURBAN AND TERMINAL SERVICE ON THE NEW YORK CENTRAL.

General Electric Company and American Locomotive Works, took place at Schenectady, N. Y., on Saturday, November 12, 1904, for the Electric Traction Commission of the railroad company and their guests.

The New York Central & Hudson River Railroad are now electrically equipping their New York Terminal for a distance of 34 miles on the main line, from the Grand Central Station, in New

York, to Croton, and for 24 miles on the Harlem Division as far as White Plains. It is the intention to handle all the traffic within this district or zone electrically and the locomotive just given trial is one of thirty to fifty which will

be used in the haulage of the through passenger trains, the heaviest of which trains weigh about 875 tons, and are to be hauled at maximum speed of 60 to 65 miles per hour. By the use of the Sprague-General Electric multiple unit system of control, two or more locomotives can be coupled together and operated from the leading cab as a single unit. The motive power may, therefore, be easily adapted to

The locomotive consists of four driving axles on each of which is mounted without intermediate gearing, the armature of an electric motor having a normal rating of 550 h.p. The total rated capacity of the locomotive is 2,200 h.p., although for short periods a considerably greater power may be developed, making it more powerful than the largest steam locomotive in existence. The motor has two poles with flat faces so as

to permit a large relative vertical movement between armature and poles as the latter move up and down with the riding of the frame upon the springs.

A longitudinal section of the locomotive frame is shown in Fig. 1. The main frame is of cast steel, and forms not only the mechanical frame of the locomotive, but also part of the magnetic circuit of the electric motors. The armatures are arranged in tandem, the end pole pieces being cast as part of the end frames and the double pole pieces between the armatures being carried by heavy steel transoms bolted to the side frame and forming part of the magnetic circuit as well as cross braces for the truck. The field coils are wound upon metal spools which are bolted upon the pole pieces. Proper distribution and division of the weight of the locomotive among the axles has been accomplished by suspending the main frame and superstructure from a system of half elliptic springs and equalized levers of forged steel, the whole being so arranged as to cross-equalize the load and to furnish three points of support. This

ing, sanding, whistling and bell ringing devices. This apparatus is furnished in duplicate, one set on each side of the cab, and is arranged so as to be easily manipulated from the operator's seat. There is a central corridor extending through the cab so as to permit access from the locomotive to the cars behind, and the contactors, rheostats and reversers are arranged along the sides of these corridors in boxes of sheet steel which are sheathed on the inside with fireproof insulating material. All of these appliances are therefore easily accessible for repairs or inspection.

The control system permits three running connections, namely, four motors in series, two groups of two in parallel series, all four motors in parallel. The motor reverser, contactors, rheostats and other controlling appliances are all of the well-known Sprague-General Electric multiple unit type. The master controller, however, is fitted with a special operating lever about 24 ins. long and capable of being moved through an angle of about 75 degrees, and the motion when turning on current is like that of

journal box. There are four of these shoes on each side of the locomotive. In the yards at the terminal the large number of switches and crossings necessitates an overhead construction in places and additional contacts are, therefore, mounted on the top of the locomotive for collecting current when the locomotive is passing over these points. This device may be raised and lowered by air pressure controlled from the engineer's cab. A magnetic ribbon fuse is placed in circuit with each shoe and overhead contact device so as to secure protection in case of accidental short circuit.

The electric locomotive has been designed to do what any steam locomotive now does. The cab is heated by a flash boiler, which also supplies steam for cars equipped with steam heating apparatus.

Power for operating the locomotive is furnished by the General Electric Company, and for this purpose there has been installed in the new power house at the Schenectady plant a 2,000 Kw, three-phase, 25 cycle, Curtis turbo-generator, delivering 11,000 volts to the line. A special high tension transmission line has been constructed from the power station for a distance of five miles to the sub-station at Wyatts.

The power station, transmission line, sub-station equipment and six miles of track is undoubtedly the most complete testing plant ever provided for trial of electric railroad motive power, and with the facilities afforded in addition to testing the new locomotives much interesting and valuable electric railroad information will unquestionably be obtained.

The general dimensions and data of the locomotive are as follows:

No. of driving wheels, 8; No. of pony trucks, 2
total weight of locomotive, 95 tons; weight on drivers, 69 tons; rigid wheel base, 13 ft.; total wheel base, 27 ft.; length over buffer platforms, 37 ft.; extreme width, 10 ft.; height to top of cab, 14 ft. 4 ins.; diameter of drivers, 44 ins.; diameter of pony truck wheels, 36 ins.; diameter of driving axles, 8.5 ins. normal rated horse power of locomotive 2,200; maximum horse power, 3,000; normal draw bar pull, 20,400 lbs.; maximum starting draw bar pull, 32,000 lbs.; speed with 500 ton train, 60 m. p. h.; voltage of current supply, 600; normal full load current, 3,050 amperes; maximum full load current, 4,300 amperes; No. of motors, 4; type of motor, GE-S4-A rating of each motor, 550 HP.

The Victorian Railways of Australia.

The report of the Victorian Railways Commissioners for the fiscal year ending June, 1904, has come to hand, and a perusal of its pages shows that a very gratifying improvement has been made. The reports says: "Notwithstanding the very large reduction in passenger and mixed train mileage, the revenue from passenger traffic exceeded the average revenue from that source during the preceding years. Excluding belated re-

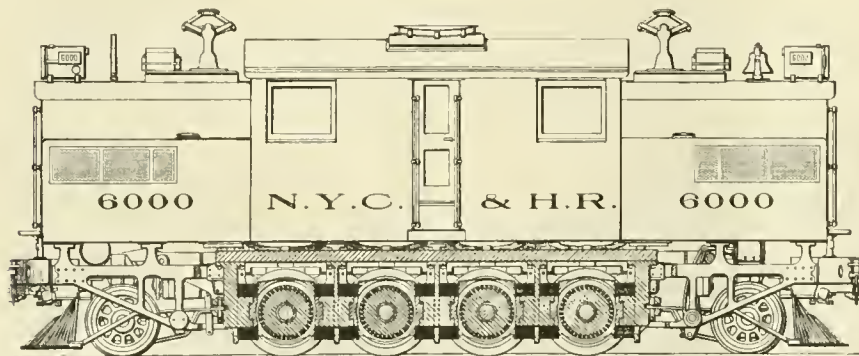

SECTION OF ELECTRIC LOCOMOTIVE FOR N. Y. C.

construction beside being strong and simple in design greatly facilitates repairs and renewals, as an armature with its wheels and axle may be removed by lowering the complete element without distributing the fields of any other part of the locomotive and a new element inserted in its place. All parts are also especially accessible for inspection and cleaning.

The pony trucks are of the radial type and are pivoted by means of radius bars to the end frame of the main truck. The design is similar to the standard construction adopted by the New York Central & Hudson River Railroad for their steam locomotives.

The dead weight on the axle is not materially greater than is customary with steam locomotives and in addition there is no unbalanced weight to produce vibration with attendant injuries to track and roadbed construction.

The superstructure consists of a central cab for the operator containing master controllers, engineers' valves and switches and valves required for operat-

an engineer pulling back the throttle lever. A current limiting device is provided in the master controller. As long as the current is not turned on too fast and does not exceed the desired limit, the automatic feature is not in operation.

In the operator's cab there is placed a General Electric motor driven air compressor having capacity of 75 cubic feet of free air per minute. The compressor is controlled by a governor which automatically cuts the motors in and out of circuit when the air pressure falls below 125 lbs. or rises about 135 lbs. A reduction in air pressure sufficient to actuate any governor, simultaneously starts up the air compressors in both locomotives when running double-header and likewise when the air pressure has been raised and any one air compressor is closed down the other will also be cut out of service.

Current is collected from the third rail by multiple-contact spring actuated third rail shoes whose supports are carried on channel irons attached to the

pairs and reconps of funds advanced in previous years by the Treasury, the percentage of working expenses to gross revenue was 52.61, the lowest since 1879, and, if these extraordinary charges be included in the working expenses, the percentage was 55.9, the lowest since 1885-6."

The general comparative statement for the past 19 years shows that although the general expenses per train mile run

is an electric resistance material for heating purposes to which has been given the name "kryptol," reports United States Consul General Mason, of Berlin. The exact method of its preparation and the proportions of its ingredients employed are not disclosed by the specifications of its patent, but it is a mixture of graphite, carborundum and clay so combined as to form a loose granular mass or powder of four grades

is thus heated directly, or the current may be transmitted through a conductor that offers enough resistance to generate heat, which is imparted to other substances by contact. This is the indirect electrical heating system, of which kryptol offers the latest and most interesting example.

The annual meeting of the American Society of Mechanical Engineers will be



REPRESENTATIVES OF DAILY AND TECHNICAL PRESS AT THE TRIAL OF THE GENERAL ELECTRIC COMPANY'S SINGLE PHASE COMPENSATED MOTOR EQUIPMENT. PHOTOGRAPHED AT BALLSTON LAKE, N. Y.

has been steadily increasing, the present year is the first in fifteen years that a surplus has appeared. The other years have been the record of heavy deficits and the present board of commissioners have been able to turn a difficult corner very neatly. Although they have been called upon to pay a large amount for pensions and gratuities last year, yet they have so managed the road as to put it on a paying basis, and the appearance of figures in the almost empty surplus column of the statement is a silent testimony to the efficient and economical management of the commission.

Mr. Thomas Tait, the chief commissioner, to whom the credit of this great improvement is mainly due, will be remembered by readers of RAILWAY AND LOCOMOTIVE ENGINEERING as having been the manager of transportation on the Canadian Pacific before he took charge of the Victorian Railways of Australia.

or degrees of coarseness, which are severally best adapted to different heating operations.

held at the society's headquarters, 12 West Thirty-first street, New York, beginning Tuesday, December 6, and last-



- | | | | |
|-------------------|--------------------|---------------------|---------------------|
| 1 A. H. Armstrong | 16 M. L. Godkin | 31 W. I. Slichter | 40 J. G. Barry |
| 2 W. B. Potter | 17 W. J. Harvie | 32 Ray Stearns | 47 J. N. Shannahan |
| 3 Theo. Merching | 18 H. W. Blake | 33 A. S. McAllister | 48 O. P. Liscomb |
| 4 Harry Farquhar | 19 J. K. LeBaron | 34 E. A. Baldwin | 49 F. G. Sykes |
| 5 F. H. Fayant | 20 F. E. Schmidt | 35 J. G. Baukat | 50 A. V. Wright |
| 6 S. F. Cole | 21 P. P. Spaulding | 36 C. Ducas | 51 Frederic Smith |
| 7 General Griffin | 22 G. P. Loughlin | 37 E. D. Priest | 52 B. J. Beebe |
| 8 C. H. Fairchild | 23 Ike White | 38 C. Loomis Allen | 53 A. P. Jenks |
| 9 M. P. Rice | 24 John Hill | 39 W. G. Bushnell | 54 G. E. Emmons |
| 10 A. E. Averill | 25 W. Hand Browne | 40 E. S. Fassett | 55 Hinsdill Parsons |
| 11 C. E. Eveleth | 26 A. G. Davis | 41 E. F. Peck | 56 C. C. Lewis |
| 12 E. J. Berg | 27 M. Milch | 42 G. De B. Greene | 57 W. B. Efler |
| 13 Harry Estcourt | 28 E. H. Anderson | 43 G. H. Hill | |
| 14 Angus Sinclair | 29 C. P. Steinmetz | 44 J. S. Pevear | |
| 15 H. D. Voght | 30 E. H. Mullin | 45 C. E. Barry | |

Improvement for Electric Heating.
Among the notable recent German inventions in the field of applied science

Electric heat may be developed by two general methods: The electric circuit may be broken, so that a voltaic arc is formed, and the charge in the furnace

ing until Friday of the same week. A number of valuable papers have been prepared and the meeting promises to be one of special interest and profit.

Walschäert Valve Motion.

The Walschäert link motion has long been popular in France and Germany, and is standard on the Belgian State Railways. In France it is extensively used on balanced compound engines intended for high speed. There were two examples of this form of valve gear shown at the St. Louis Exposition. One was on the B. & O. Mallet articulated engine, illustrated on page 283 of the June, 1904, issue of RAILWAY AND LOCOMOTIVE ENGINEERING, and the other is on the De Glehn four cylinder compound built in France for the Pennsylvania Railroad.

The Walschäert gear makes use of, and combines two motions, one from a crank arm, which is equivalent to an eccentric, and the other from the crosshead. The main crank pin is fitted on the outside with what is called a return crank; this is an arm which extends back from the main pin toward the axle, but is offset from the center of the axle a distance equal to half the throw,

The connection from the crosshead is made by what is called a combination lever attached at its lower end to a short union bar which has one of its ends secured by pin connection to the crosshead. The eccentric and crosshead motions are, therefore, combined and together influence the motion of what may be called the valve rod crosshead and this combined motion is, therefore, imparted to the valve.

The effect of this combined eccentric and crosshead movement on the valve is that it produces a valve movement equivalent to that given by an eccentric having angular advance, but in this case the lead is constant and does not alter as the reverse lever is notched up or down.

This valve gear has one obvious advantage, being outside, it is easy to get at, and as it does away with heavy eccentrics and straps and can be made with comparatively light parts, it should be adapted to American locomotive practice as a welcome alternative from

Double forges, the speaker said, in his opinion were preferable, as they are economical of floor space when at an angle of 45° with 15 ft. from wall to center of stack and 20 ft. from center of stack to center of shop. These two forges and their working room will cover about 525 sq. ft. of floor space and will be good for any kind of work except frames or furnace work.

If smoke stacks are not employed the shop cannot be called ideal. The throat of the forge hood at the stack connection and the stack itself should be large enough to take away all the smoke and nearly all the heated air above the forge level.

In designing forges thought should be given to proper dimensions for heating qualities, storage of fuel, convenience, cleanliness and economy in fuel and shop space. Many times there is much space occupied for coal and coke boxes as that occupied by the forge itself. Large forges should be made cir-

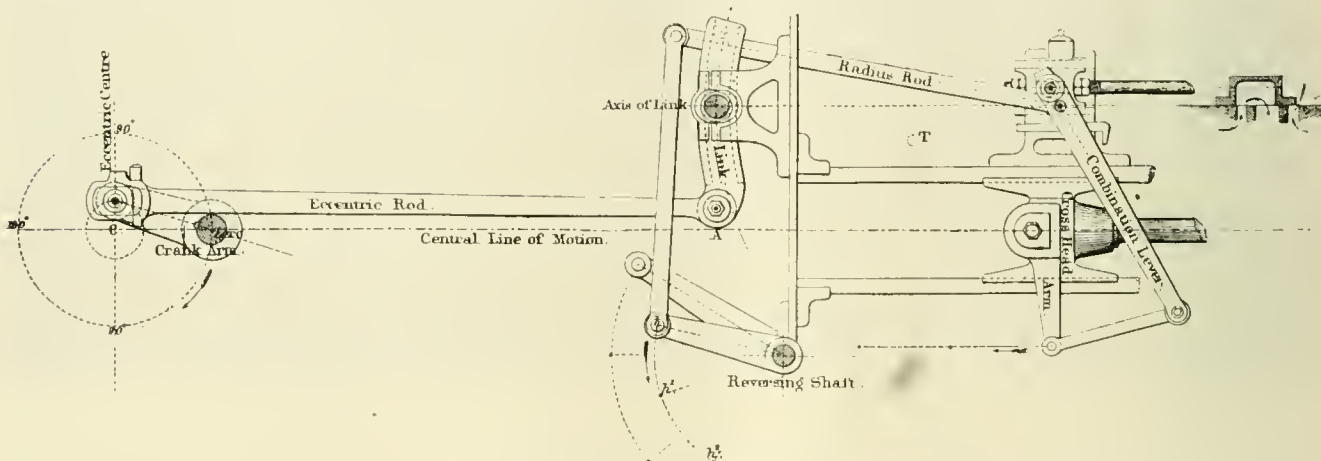

WALSCHÄERT VALVE GEAR
Illustration from *Link and Valve Motions*—Auchincloss.

and the center of this eccentric is placed on a line at right angles to that joining the center of the axle and the crank pin. There is, therefore, no angular advance and, as far as the valve is concerned, it can have no lead given to it by such an eccentric.

The Walschäert link is pivoted on a central fixed point and oscillates freely about it. The radius rod carries the link block, and this block is moved up and down in the link by an extension of the radius rod and a connection with the lifting arms of the reversing shaft. It is evident that when the link block is above the pivot point of the link it will move backward when the eccentric rod moves forward, and vice versa, thus resembling indirect valve motion. When the link block is below the pivot point of the link it moves forward or backward with the eccentric rod and in this particular resembles direct valve motion. The curve of the link is that swept out by the radius rod.

some of the heavy shifting link gears which our modern monsters of the rail have been compelled to use.

The Ideal Blacksmith's Shop.

The ideal blacksmith shop of to-day is one built of structural steel incased in brick, the roof of which has been designed to stand the constant jarring caused by the large steam hammers and to have a large factor of safety after this, and the requirements of the supports of the masts for the large jib cranes have been satisfied.

This, in effect, is how Mr. A. W. McCaslin, master blacksmith of the Pittsburgh & Lake Erie, approached the subject in his paper recently read before the National Railroad Blacksmiths' Association. The eaves should be about 30 ft. from the floor and the roof should be of monitor design with pivoted windows on sides and ends.

cular and should have sufficient space allotted to them for the convenient handling of heavy work.

Concerning volume and pressure of air, Mr. McCaslin gives it as his opinion, based on years of experience, that any volume of air with a constant pressure of from 14 to 16 ounces through an upright opening in the tuyere, equal in area to 2 or 2½ sq. ins., is about the proper thing for a railroad shop, and the tuyere should be at least 10 ins. below the top of the forge.

There should be special furnaces for special classes of work. The large, reverberatory furnace and the billet furnace, which latter may be of similar design, and if so, will also make it useful in heating for small forgings. These furnaces also answer for heating car work to be formed on machines. Others, such as case hardening and spring furnaces should be in the ideal shop, together with furnaces for heading and

bolt machines, blue welding furnaces, etc.

The installation of steam hammers today calls for greater consideration than it did some years ago. The introduction of steel for many heavy locomotive parts requires the use of heavier hammers, larger piston rods and better kept dies and more secure foundations. The number of cranes should be ample for all purposes and they should be placed so as to interchange loads, but should not interfere with each other.

A most necessary tool in the ideal shop is the bulldozer. Furnished with proper tools this machine will compare well with the steam hammer in money earning capability. The modern smithy has steam hammers, bulldozers, heading machines, forging machines, belt machines, punch and shears, etc., as mentioned above, and the foremen should inform his men that the tools were

4,000 Imperial gallons and 10 tons of coal.

There are several novel features in this machine. She is a Pacific type engine and the fire box, which is a Bel-paire, comes out over the journal of the small carrying wheels at the back. The corner of the slab frame with its stiffening ribs is something interesting. The reach rod has a knuckle and a lever support which is placed between the main and rear drivers. The valves are of the piston type, actuated by Walchäert valve motion. A noticeable feature of which is that the outer end of the main crank pin, where the return crank for the valve gear is attached, is finished square so that there is no chance of the return crank slipping and altering the point to which the eccentric rod is attached. The valve stem moves in two bracket guides, between which the radius rod

many in 1871 by Wohler to find out if there was anything in the theory. These experiments were followed by those conducted by Spangenburg and Martens and Bauschinger. In England in 1886 Sir Benjamin Baker gave a record of tests of material for the Forth Bridge, and the same subject has been most carefully investigated by Mr. J. E. Howard at the U. S. Government Testing Bureau at Watertown.

The speaker told his audience that the sum total of all these researches is that iron and steel are more amenable to the laws of nature than had previously been supposed. All steel will eventually break when subjected to recurring stresses. A fatigue break is only a matter of time, but when the recurring stresses are much below the elastic limit of the steel, the life of the metal is almost indefinite.

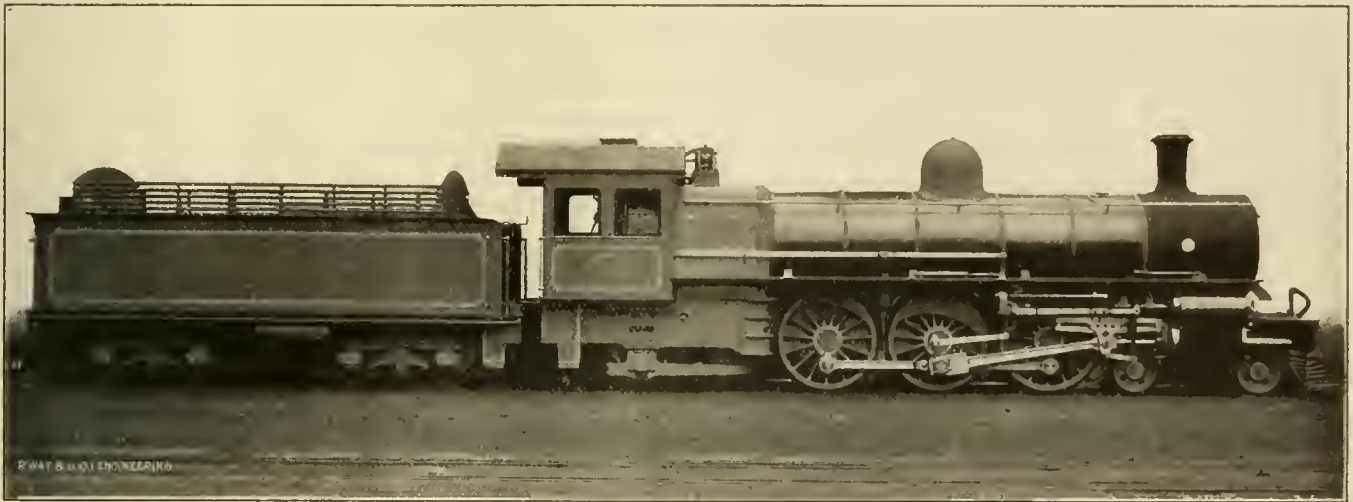

CENTRAL SOUTH AFRICAN 4-6-2 ENGINE WITH WALSCHÄERT VALVE, GEAR.

bought for a purpose, and should be used effectively and kept in proper repair.

A Central South African 4-6-2.

Our illustration is of an engine in passenger service in the "Dark Continent." She is known out there as belonging to class No. 10 and has cylinders 18½x28 ins. and 62-in. wheels. The weight of the engine in working order is 70 tons, 12 cwt., and that of the tender is 49 tons, 7 cwt., making a total of 119 tons, 19 cwt. The tons here referred to are what are called long tons of 2,240 lbs. each.

The tractive power is about 24,730 lbs., calculated on the assumption that the mean effective pressure in the cylinders is 80 per cent. of the boiler pressure, which is 200 lbs. The grate area of this engine is 35 sq. ft. and the heating surface is, in fire box, 128 sq. ft. and in the tubes 1,714, making 1,842 sq. ft. in all. The capacity of the tank is

and the combination levers are attached.

The tender trucks have equalizers on top of the axle boxes; to these equalizers springhangers are fastened. Although the machine was built in Great Britain, the axle box covers have a decidedly M. C. B. appearance, and the iron pilot and the cab are familiar objects to us. The photograph from which our half-tone was made was sent to us by our valued friend Mr. Philip A. Hyde, chief locomotive superintendent of the Central South African Railways.

Fatigue of Metals.

"What is this 'Fatigue of Metals' of which we have heard and still hear so much?" This is a question which Mr. Robert McF. Doble asks in the course of a most instructive paper recently read before the Pacific Coast Railway Club, and he then proceeds to answer it.

There were experiments made in Ger-

For example, if a bar of steel or iron be subjected to a tensile stress of 30,000 lbs. per sq. in., or if it be subjected to a 30,000-lb. compressive stress, and either of these be applied and relieved, the bar will stand a given number of them. The "range" of the stress is 30,000 lbs. If the same bar is subjected to 15,000 lbs. per sq. in. tensile stress and then to 15,000 lbs. compressive stress alternately, the "range" is the same as before, but the material will only last half as long as in the former cases, supposing the stresses to be continuously applied until the bar breaks down.

Wohler found that the rupture of a test bar of wrought iron could be accomplished by one application of 55,000 lbs. per sq. in. tensile strain, or by 210,000 applications of 38,000 lbs. per sq. in. A piece of spring steel subjected to bending broke under 81,000 applications of 95,000 lbs. per sq. in., but it took

1,165,000 applications of 53,000 lbs. per sq. in.

Consideration of the results of endurance tests point to the advisability of using a metal for forgings which has a very high elastic limit and so proportioned, if they are to stand frequent alternating, as to cause these stresses to come always well within the elastic limit. For such forgings modern practice has shown that steel should be used, and the higher the steel is in carbon, the longer its life will be, when other things are equal.

Helping Grand Trunk Apprentices.

A very successful experiment in the matter of practical education has been made in the Port Huron shops of the Grand Trunk Railway. There are between six and seven hundred men employed in the shops and of these about a hundred are apprentices. Mr. J. T. McGrath, the master mechanic, some time ago inaugurated a system under which the apprentices receive from competent men, instruction in mechanical drawing and other branches, calculated to assist them in their manual training in the shop. Soon after the classes had been formed and work had got under way, a literary and scientific institute was organized among these students, but the movement became so popular that full fledged mechanics and men who had worked at their trade for years joined in as well. Last winter a series of lectures was given by car and locomotive builders. The literary and scientific institute was given the use of a neighboring building, and a library was started. Branches of this institute were formed in the shape of an horticultural society and a camera club. The horticultural branch fully justified its existence by beautifying the shop grounds, and it is to be hoped that the camera club duly recorded their efforts. The shop "bosses" encourage the men in all this and a local paper says that no more satisfied body of workmen are to be found anywhere in the country than the Grand Trunk men at Port Huron, Mich.

Danger of Storing Coal.

There is one peculiarity about stored coal for railroad use, when it does get on fire that it is not very generally known. Coal stored in great heaps deteriorates in quality as time goes on; this deterioration is slow oxidation and oxidation slow or fast is always accompanied by the generation of heat. There is no way of preventing this action, but there is a way of avoiding serious results and that is to provide means for rapidly carrying off the heat, and that is best accomplished by the free circulation of air through and around the pile. The

peculiarity about the fire in the interior of a pile of coal is that it cokes a layer of coal all around the fire and this coked layer will not readily let water through, so that drenching the pile from the outside and expecting the water to soak in and put out the fire is an expectation which is not likely to be realized. The way to put out a fire in the center of a coal pile is to push a sharp pointed piece of perforated pipe into the burning mass, couple the piece of pipe to the shop hose and turn on the water.

Petrol Locomotive.

A narrow gauge petrol locomotive for industrial railway service has been put into service in the North of England. The motor is a horizontal type and is capable of developing 20 brake horse power at 600 revolutions. It has the general appearance of a locomotive, but the casing of the whole resembles the outside of a Belpaire fire box. The driving wheels are four in number and are 18 ins. in diameter and are driven from the motor by chain gear. The engine is fitted with a heavy flywheel, which is required for rail traction. Two speeds forward are provided and two for reverse motion. These are three and eight miles per hour. The novel little engine looks something like a miniature steam locomotive with a radiator coil in front of the "smoke box."

The Trackless Trolley.

What some people are pleased to call a "trackless trolley" is being put in operation by the people of Monheim, in Prussia. The road is about 2½ miles long and two overhead wires, made of hard copper, are suspended about 18 ft. above the middle of the road. These hang from cross wires carried on iron pillars. Two or more passenger cars and an electric locomotive make up the train, and freight cars may also be attached. Farmers and others may, on payment of a suitable fare be permitted to attach their wagons to the tail of the train. The cars are equipped with motors and rotary poles with sliding blocks on top of the vehicles connect with the overhead wires and at the same time allow the cars a certain amount of side motion. In fact, we expect some pretty dextrous steering will have to be done in order to prevent a great deal of what politicians call "wobbling" being observable in the motion of this train.

Lackawanna Locomotive for Cornell University.

The Delaware, Lackawanna & Western have loaned a locomotive to Cornell University for the purpose of allowing students of the department of railway mechanical engineering in that institution

to make various tests. The idea is to familiarize the students with the locomotive on the road and with actual service conditions. The engine will run between Ithaca and Owego. Indicator cards will be taken. Water consumed will be measured. Heat units lost or turned into useful work will be ascertained, and coal consumption will be noted. This form of practical instruction is open to any seniors or juniors who are taking the railway course. This engine is the fourth locomotive loaned to Cornell by the Lackawanna, and even after the experimental locomotive which the university is getting from the Baldwin Works is installed, Professor Hibbard says it is still hoped that they will be able each year to get a road engine for road service tests for a short time each year.

Race with Locomotive and Motor Car.

Press despatches say that a gasoline motor car recently built for the Jamestown, Chautauqua & Lake Erie Railway has proved to be a great success, when a preliminary test was made. The gasoline motor is a 150 h.p. engine, and when the initial trip was made by the officers and directors of the road, an ordinary steam locomotive was made to accompany its rival in case the gasoline machine failed. The steam locomotive ran along a track practically parallel to the one of which the motor car moved. A run of about 12 miles was made, from Jamestown to Bemus Point, along the shore of Chautauqua Lake. The distance was covered in 14 minutes, which included slowdowns for curves and poor track. The motor car traveled at about 60 miles an hour and incidentally ran away from the steam locomotive which was doing its best to see that the motor car did not come to grief. Everybody on the gasoline car was highly delighted but at the end of the run the crew of the steam locomotive were too far behind for anyone to learn what they thought of the performance.

A young farm hand in Vermont became touched with religion, and one night at a prayer meeting intimated that he would contribute \$2.00 to the mission box when he sold his calf. About that time he got a job firing on the Boston & Maine and went away without thinking of the contribution. Some months afterwards he returned to the village after evening service had begun, and as he entered the meeting house the congregation was singing, "The half was never told." His guilty conscience made him think the words were "The calf was never sold." As the singing ceased the fireman stood up and exclaimed, "The calf sold right enough and I've got the two dollars ready for you."

A Collision Baggage Car.

A man in Cleveland has recently invented a baggage or mail car especially designed for collisions, if we are to believe a statement in the *Philadelphia Record*. The car will consume the shock of a collision and thus not only save itself but prevent damage to the rest of the train.

The means for doing this most desirable thing is an arrangement of the under frame of the car which, we are told, is combined with a series of springs and a telescopic framework which permits the springs to act as a cushion and an absorbent of concussion. The platforms are of special design which permits them sliding under the car in case of accident.

Now this is all very well as far as it goes, but it does not go far enough.

Steel Car Company, of Pittsburgh, will be closely followed and that the Pressed Steel Car patents will be used by the Canadian builders. The shops will, when completed, be able to turn out about 10 passenger cars per month and about 20 freight cars per day, but the output is to be increased. The company have bought about 50 acres of land, which is close to the Lachine canal and is within easy connecting distance with the Grand Trunk and Intercolonial Railways. The president and general manager of the company is Mr. W. P. Coleman, whose office is in the Board of Trade Building, Montreal.

New Parlor Cars on the B. & A.

The Boston & Albany Railroad have recently put on some very beautiful parlor cars which were built at the Pullman

served. The observation room has twelve solid, heavy chairs covered with Spanish leather. Overhead the car is exceedingly plain, but the effect of what appears to be roof beams showing through and dividing the panels, is exceedingly rich. Modern sanitary practice has been followed and dust and germ collecting ornaments and heavy curtains have not been used. The other cars are named the Vanessa, Valkyrie and Vacuna. We are indebted to Mr. John Howard, superintendent of motive power and rolling stock of the N. Y. C. and the B. & A. for information concerning these cars.

Some Kinds of Railroad Evidence.

The style of evidence sometimes offered to a claim agent by employees of the road he is on was brought out in an



AN OBSERVATION PARLOR CAR ON THE BOSTON & ALBANY RAILROAD.

The body of this car has not been arranged to collapse in the stress of a collision, and it seems to us this is a serious oversight. Mail bags and pouches are soft and can stand a good, hard bang, but trunks are hard things, and they should also be designed on the concertina principle, for use in this car, and, moreover, readily collapsible baggage men only should be employed on this car. The whole thing ought to fold up into nearly nothing, and open out full size after the collision has taken place.

The Canada Car Company is the name of a new concern which is building shops at St. Henry, near Montreal. The company intend to begin with the manufacture of wooden cars, but steel cars will eventually be built there, and it is understood that the methods of Pressed

works. The car we illustrate is the Vashti, and it is in its own way probably as beautiful as was the queen of Ahasuerus, king of the Medes and Persians, for in the book of Esther we are told that "she was fair to look on."

This modern Vashti, however, is one of four cars which run between Boston and New York. They are finished in vermilion wood, rubbed to a dull finish, ornamented with light lines of various colored woods, inlaid. The style is what is called Colonial. The cars are furnished with revolving chairs upholstered in green tapestry, the carpets are also green in tone and the clearstory windows are filled with leaded art glass, which preserve the same tint.

The observation parlor cars, of which there are two, are equipped with a buffet where a light luncheon may be

anonymous paper read a short time ago before the St. Louis Railroad Club. The writer said a well-known claim agent was trying to locate the damage to a carload of threshers loaded on a flat car. The correspondence came in with the statement from one zealous employee: "Car passed here with no rough handling; side and end doors sealed; no evidence of leakage."

This kind of evidence reminds us of the inquiry from the office of a railroad superintendent which we once saw. It happened that a drawbar had been pulled out of some flat car used on construction or track repair work and a report had been duly sent in. The chief clerk of the superintendent was not a railroad man but had been in a lawyer's office, and he believed in collecting evidence in plenty before he let the matter go be-

fore his chief, so the correspondence was kept going until it was over half an inch thick and the original flat car and draw-bar had been long buried out of sight. When the bundle of papers came back to the office of the M. M. the burning question put with all the force which the superintendent's name could command, but initiated by the "law clerk" was, "Why had the man who skidded the

diately purchased a small claim, and having prospected it they found that they possessed a gold mine.

It may be remembered that Oliver Martin's pickax struck the famous \$30,000 nugget, the largest ever found in California, when he was digging his partner's grave; that the great mine of the Antilles was discovered through the accident of a rabbit running to earth,

Work of the Rayner Water Changing Apparatus on the P. & L. E.

According to the usually practiced method of washing out boilers, when the fire is drawn the flue sheet and the flues are exposed to cold currents of air, and unequal contraction follows which tends to cause leaks; steam is allowed to escape into roundhouse atmosphere, and water is spilled over the floor, depositing mud and scale on it; cold water is frequently put into hot boilers again causing unequal contraction; time is required to blow off steam, cool the boiler, wash it out, close it up, fill with water and fire up. All this results in considerable cost for labor; loss of the heat in the water and in the steam blown out; and locomotives kept out of service during the time required in doing the work. By the new method the above mentioned difficulties are largely overcome, and this results in an increased efficiency of the locomotives, a noticeable improvement in roundhouse conditions from a sanitary standpoint, and an appreciable economy in cost of roundhouse work.

Some of the different kinds of service rendered by the Rayner Water Charging apparatus at the McKees Rocks roundhouse on the Pittsburgh & Lake Erie Railroad, taken from actual practice, are as follows:

Locomotive No. 302, P. & L. E., Atlantic type passenger, with 115 lbs. steam and no fire, was emptied, and 18 minutes' work was done on empty boiler, afterwards boiler was filled, fired up and engine left roundhouse, all in 80 minutes.

Water Change.—Heavy freight locomotive, P. & L. E., No. 174, fire was banked with steam pressure at 112 lbs., water change was made in 37 minutes and steam pressure did not fall below 50 lbs.

Passenger engine No. 95, 4-4-0 type, was emptied for boiler work at 3.11 P. M., work was finished at 4.45 P. M., boiler was still warm but empty and under no pressure. From empty warm boiler to full boiler with fire and 100 lbs. steam pressure in twenty minutes.

Locomotive No. 792, L. S. & M. S., from shop. From cold, empty boiler to boiler filled, fired and with 90 lbs. steam pressure. 32 minutes.

Engine No. 89; no fire; steam pressure was 120 lbs. Engine was needed, and it was found necessary to pack throttle valve before allowing it to go out. In 46 minutes the pressure in boiler was reduced from 120 lbs. to zero, six minutes' work was done on boiler, and it was filled and heated up to 70 lbs. steam pressure.

Engine No. 199, class 2-8-0, steam pressure 118 lbs.; no fire; water changed in 39 minutes.

Engine No. 98, passenger; no fire;



INTERIOR OF OBSERVATION ROOM IN PARLOR CAR VASHTI.

wheel not been dealt with more promptly? Please explain."

Curious Discoveries of Riches.

It is said that a flagman waiting to protect a train on the weary track of a New Zealand railway began amusing himself throwing stones, and, noticing something glitter in a stone he was about to shy at a telegraph pole, he made an examination and found the glittering stuff was real gold.

He proceeded then to examine the ground on which he found it and he again remarked the existence of the same precious metal. He and a friend imme-

diately purchased a small claim, and having prospected it they found that they possessed a gold mine. And now a rich gold mine has been discovered at Tokio, capable, they say, of producing ten million dollars annually, at a time when the country needs all the gold it can amass.

And now a rich gold mine has been discovered at Tokio, capable, they say, of producing ten million dollars annually, at a time when the country needs all the gold it can amass.

steam pressure was 90 lbs. Water was changed in twenty-two minutes, and pressure in boiler did not drop below 65 lbs.

Engine No. 167; arrived at roundhouse with 95 lbs. steam and no fire; engine was marked up for repair shop; water was blown out and the steam pressure was allowed to drop to 65 lbs. in twenty-five minutes, after which the locomotive was moved to repair shop by its own steam at this pressure.

Engine No. 165, 2-8-0 class, was heated from empty, cold condition, by use of live steam to allow locomotive to be moved to another stall.

Passenger engine No. 301, Atlantic type; fire was banked; steam pressure 100 lbs.; 2 gauges water before commencing; water was changed in 37 minutes and pressure did not drop below 75 lbs.

M. C. B. Drop-Testing Machine at Purdue University.

Our illustration represents the Master Car Builders' drop-testing machine, as installed at the laboratory of Purdue University, Lafayette, Ind. Its drop weighs 1,640 lbs., and is of forged steel. Its weight meets the requirements of the M. C. B. specifications for coupler testing as well as those of the International Association for Testing Materials, with reference to axle testing. The drop is handled by a wire cable served by a reversible hoisting engine within the locomotive laboratory. The anvil or base of the machine weighs 17,000 lbs. and is carried by a nest of coiled springs which in turn are mounted upon a suitable foundation plate. The machine rises to a total height of 55 ft.

This apparatus was developed by the M. C. B. Association. At their annual meeting in 1898, the association appointed a committee to define fully the contour lines of M. C. B. couplers, and to propose specifications which might guide railroad companies in the purchase of new couplers. The report, which was subsequently presented, dealt with the coupler question very fully, recommending among other things that couplers be subjected to a series of tests under a drop machine. The committee not only defined the nature of these tests, but presented a design for a machine to be employed in carrying them out.

It was in the work of Mr. W. W. Atterbury's committee that the present M. C. B. drop-testing machine had its origin. As time went on the original drop-testing machine, which had been located at Altoona, was improved in matters of detail, and became useful not only in testing of couplers, but in testing of draw gears as well. Meantime, the chairmanship of the coupler committee had been transferred to Mr. R. N. Durborow, who in this manner became re-

sponsible for the later development of the machine.

"How Not To Do It."

There has been a spectacular head-on collision of two 60 ton Baldwin engines of the passenger type, at the Delmar race track, at St. Louis. The machines were said in the press dispatches to have 70 in. driving wheels and were let loose under full steam from opposite ends of a mile of temporary road.

This performance was dignified by the

trying to run past a danger signal and halted by a perfectly workable and simple stop mechanism, capable of doing business in the depth of winter—that would be a sight worth seeing. Then would be the time to call it a test and to bring along the corps of competent observers and all the rest of it.

Marshall P. Wilder at the Grand Cañon.

Everybody knows Marshall P. Wilder. His genial presence and funny stories

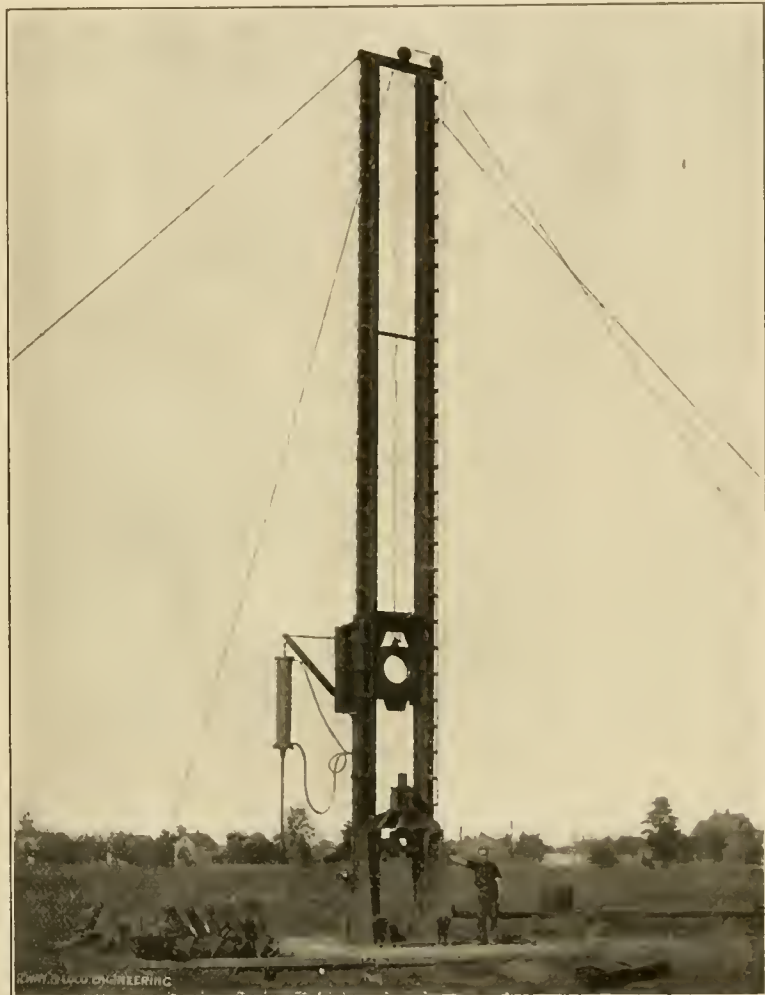

M. C. B. DROP TESTING MACHINE AT PURDUE UNIVERSITY.

name of "test," and we are told that a corps of competent men were present to ascertain by actual observation, and from a scientific and experimental standpoint what results would follow such a collision. Notes of the condition of the track were made, etc., etc., etc.

All this is pure bosh. It was not a test in any sense of the word, and no new facts concerning collisions or how to avoid them have been brought to light by it. A moving picture machine took photographs of the affair for reproduction in the various theaters of our large cities and that is about all the scientific record anyone will ever see or hear of.

The spectacle of a full sized locomotive

make him welcome in every newspaper office. On the stage he creates several laughs a minute. His magazine articles have been smilingly read by millions.

Wilder sails from San Francisco in October for a trip around the world. On the way he plans to spend a few days at the Grand Cañon of Arizona. With a twinkle in his eye he remarked, when a friend suggested the incongruity of a funny man appreciating so solemn a thing as this centuries-old world-wonder: "It's only a step, you know, from the sublime to the ridiculous. If it don't make the spirit of the cañon smile to see Marshall P. Wilder astride of a white mule, zig-zagging down the

trail, it will be because the said spirit is blindfolded or else it doesn't know a joke when it sees one on the trail."

If serious attempts to describe the Grand Cañon often excite mirth, why should not the sallies of the humorist interest the sober minded? Anyhow, what Wilder writes about the titan of chasms will be worth reading and will be read.

The Pratt Institute Free Library, Brooklyn, N. Y., has just opened to the public an Applied Science Reference Room, devoted to technical and trade literature. It is desired to make this department as useful as possible to the practical men engaged in the various trades and industries. The room contains books, bound periodicals and current periodicals. It is in charge of Mr. Herbert L. Cowing, a graduate of the mechanical engineering course of Cornell University. The room is open every day from two till six, and on Monday, Wednesday and Saturday evenings until 9.30. The library authorities desire to form a collection of trade catalogues and bulletins bearing upon all branches of industry. These catalogues will be accessible to the public, and the librarian informs us that they will be glad to receive such catalogues from any of the advertisers in, or readers of, RAILWAY AND LOCOMOTIVE ENGINEERING.

Ventilation of Passenger Cars.

A very interesting and successful experiment in passenger car ventilating has been carried out on the Pennsylvania, by Prof. C. B. Dudley. An ordinary coach holds approximately 4,000 cubic feet of air and seats about 60 persons. In order to have relatively pure air, the carbonic acid breathed out by human beings should not exceed 2 cu. ft. in 10,000 cu. ft., yet 6 cu. ft. in 10,000 may be present as a maximum and the ventilation be fairly described as good. This becomes apparent when it is stated that an ordinary closed coach often contains as much as from 15 to 20 cu. ft. per 10,000.

The amount of carbonic acid given off per passenger per hour is assumed to be .6 of one cubic foot, and with 60 persons in a car the total amount which they would produce in an hour would be 36 cu. ft. If the desirable minimum of 2 cu. ft. of carbonic acid per 10,000 cu. ft. is to be had under these circumstances, it would be necessary to supply the car with 180,000 cu. ft. of fresh air per hour. This means that the cubic contents of air in the car would have to be changed 45 times in the hour; or, to put it another way, a car full of air would have to be got rid of every $1\frac{1}{3}$ minutes.

That is the problem as it stands. It is, however, impossible to pass this quan-

tity of air through a car in the given time in cold weather without unduly chilling the occupants, and the efforts of Professor Dudley have been directed to securing the best possible ventilation consistent with proper maintenance of temperatures.

As the cars generally carry less than 60 persons on an average, and as the opening of the end doors at stations introduces fresh air, the Pennsylvania arranged for the passage of 60,000 cu. ft. of fresh air through the car per hour. This is equivalent to 10,000 cu. ft. of fresh air per passenger per hour, and reduces the cubic quantity of carbonic acid in the air of a car from 15 or 20 down to 10 cu. ft. This may not be ideal ventilation, but it is a very great improvement on ordinary conditions.

Outside air is taken in through two hoods on the roof of the car, placed on diagonally opposite corners. It passes down two pipes, each with an area of 100 sq. ins. and is delivered below the floor into the space between the outside and nearest intermediate sill. From

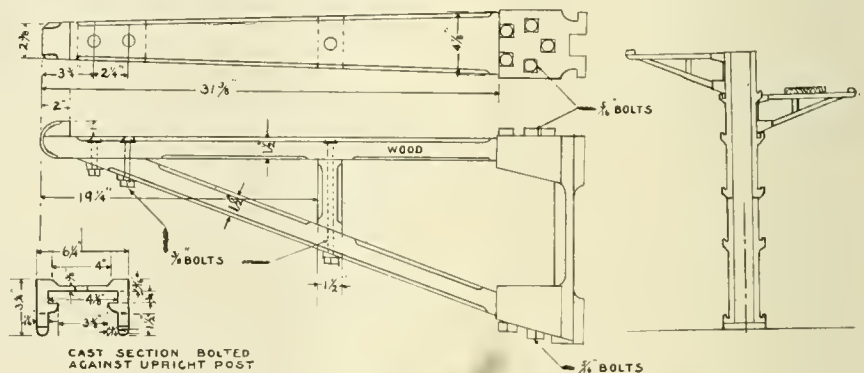

PAINT SHOP SCAFFOLDING, PENNSYLVANIA LINES.

these fresh air boxes the air passes up through ducts in the floor which compel it to encounter the heating pipes and thence it goes to the interior of the car. It is eventually drawn off and passes out through Globe ventilators placed on the center line of the clearstory. There is provided one square foot of heating surface for every 240 cu. ft. of fresh air drawn in per hour, and this has been found a most satisfactory allowance with from 20 to 30 lbs. steam pressure.

There are two ways in which the temperature of the car can be regulated. One is by altering the pressure of steam in the heater pipes and the other is by restricting the amount of air going out of the ventilators. Special lamp ventilators were provided which carried away the lamp gases only and did not draw off fresh warm air from the car. The deck sashes were made permanently tight with the advantages that locomotive smoke and cinders were kept out, cold draughts from above did not annoy passengers and the lamps burned with steadier flames.

Car Paint Shop Scaffolding.

A good form of paint shop scaffolding is to be seen in the shops of the Pennsylvania Lines (North-West System) at their Allegheny shops. Upright posts, $6\frac{1}{4} \times 7$ ins., are planted 3 ft. in the earth. On each side of the posts cast iron channels are bolted, made in two sections, and these channels have notched lugs cast on their sides spaced at varying intervals.

Our illustration shows the triangular form of scaffold bracket which is used. It is light and strong, being made of hard wood, the top and bottom members being fitted into cast iron sockets, which are joined together by a web. At the back of each socket there are two lipped projections made to fit in the grooves of the post channels.

When a triangular bracket has been entered at the top it can be slid up and down in the channel but cannot come out, except at the top and may be suitably secured at the desired height.

The notched lugs cast on the sides of the channels are spaced at odd intervals,

care having been taken to arrange them so that the workmen will be able to easily get at the woodwork of the cars; for example, one position puts the top of the windows within reach and another the bottom. The method of securing the triangular scaffold bracket is to place a piece of $\frac{3}{4}$ in. round iron across the lugs and in the notches. This piece of $\frac{3}{4}$ in. iron, or bale, as it may be called, has its ends turned down so that when lying in a pair of notched lugs it cannot work out endwise. The bottom of the bracket casting being made flat rests squarely on the round iron bale and holds the scaffold bracket in place. The whole arrangement is light and strong. It is easily and quickly manipulated.

Grand Prize at St. Louis Exposition.

The American Locomotive Company have been awarded a grand prize at the Louisiana Purchase Exposition for their exhibit, and the officers of the company were given collaborators' grand prize gold medals.

General Correspondence.

Modernizing an Ancient Shop.

Habit and custom are the strongest things to overcome in introducing new machinery and methods in railroad work, as I found to my vexation in trying to modernize a shop in the South that had been recently equipped with some new machinery in the wrought iron department, such as a bolt header, steam hammer, double end lathe and double screw cutter.

The master car builder, knowing my capacity as a machine man, offered me a good position to help his foreman get his new machines in working order, and to get up the necessary forms, dies and labor saving contrivances that are necessary in the general run of railroad work of which I had had long years of experience.

Now, it happened on this particular road, the shop I was assigned to had been in existence about 45 years, and from all appearances the same set of men who started with the first whistle that blew for work were the same set that I found there on my arrival, with the exception of a few sons and grandsons, who were endeavoring to learn how.

To see that these men were not favorably impressed with the advent of new machines and your humble servant, in particular, would have been easy to a night owl at high noon, but I consoled myself with the assurance that time would smooth this feature and reconcile them to the inevitable.

My foreman assigned me to the bolt heading machine. There was little work to do on that machine, which gave me ample time to chase around and scheme on different things that had to be improved on. By importing a man we soon got the new axle lathe started. An emery grinder for the heavy axle tools had also been set up, and after a few days grinding had to be trued up, and as I was supposed to keep things in shape, I went to the tool room and inquired for the tool to true the emery wheel. Now, I am quite sure the ancient artisan who presided over this division of the shop had children of his own when the shop was built; anyway, he had an astounding opinion of his own importance and had been there so long that he considered he was monarch of all he surveyed, and the small fry looked upon him as a Chinaman does on his dead ancestors—with a feeling of reverence and idolatry.

My reference to the tool to true the emery wheel brought the response that

they had a carbide there for that purpose, and as it was valued at \$65, a permit had to be got from the M. M. before I could have it, and if anything happened to it I would be responsible. This rather staggered me, and as I had not been used to handling such valuables on an emery wheel, I asked the venerable guardian of the jewels if they did not have something cheaper than that, for I could get along with a tool costing about two bits (25 cents), if they had it in stock. No! \$65 worth of carbide was all they had for the purpose. I did not propose to

washers, as in Fig. 3, this simple tool will do splendid work and last a long time with reasonable care.

All this time the M. C. B. was prodding the foreman to get up more improvements, and the latter's experience in the machine line being very limited, he advanced all kinds of wild schemes for forms and dies on the machines, and as the making of crown sheet bolts was a very costly process, he had dies made for the bolt machine as per sketch No. 4. I looked them over and saw at once that they would not work with a bead on

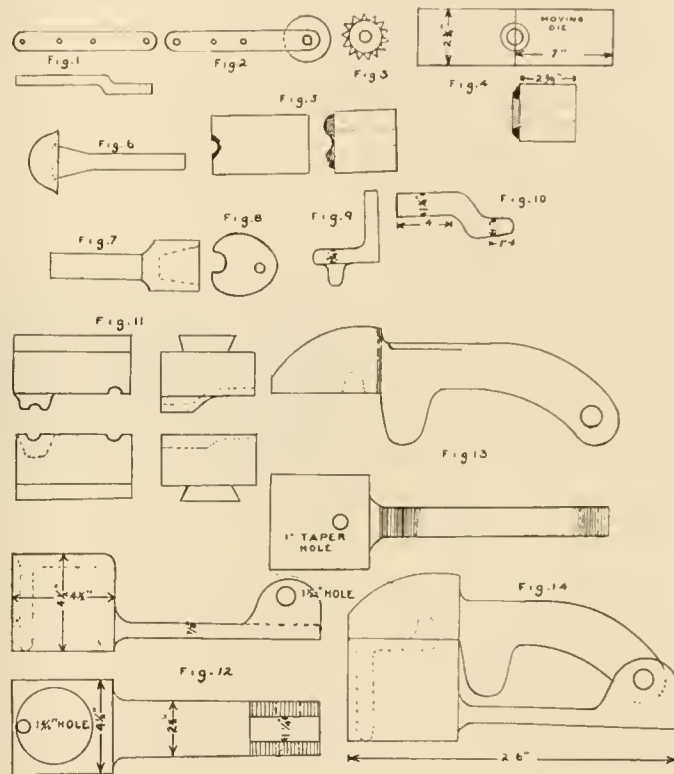

OLD AND NEW DEVICES USED IN MODERNIZING AN ANCIENT SHOP.

take any desperate chances. I went back to the shop, secured two pieces $\frac{1}{4} \times 1 \frac{1}{2} \times 12$ ins. long and offset them as in Fig. 1—five $\frac{1}{2}$ in. washers, one $\frac{1}{2} \times 2$ in. bolt and nut, and three $\frac{3}{8}$ in. rivets from the tinsmith constituted the outfit, and completed the tool as in Fig. 2. In 15 minutes' time I had the wheel nicely dressed. I had forgotten this incident when, the next day, a machinist came in and wanted to see the tool I had made for dressing the emery wheel, and after he went out I had calls all afternoon for the same purpose, and this feat alone caused quite a sensation, and the ancient one that sat on a pine stump and watched the first brick laid never recognized me after that, because I knocked his cherished carbide out of time. By using three steel

the moving side, and I told him so, and explained that the bead would catch the hot iron and tear off that side or would pull the bolt with it and tear off the other side, but he could not see it that way, so I put them in the machine and spent one and a half days trying to get them to work, but could not get a perfect bolt in that time, and finally got mad and gave it up and told him if he would let me fix the dies I could make them work, I was certain, but if not to put some one else at the machine and I would go ahead at something else.

He finally consented, and I proceeded to grind the bead on the moving die as per sketch No. 5, with the result that I was able to get out a set of as perfect crown sheet bolts as was ever seen at a

total cost of \$1.50 per set, as against about \$21 for the old way.

I was subjected to a great amount of "joshing" while I was trying to get these dies to work and this was not conducive to my peace of mind, but after I perfected them, as per sketch No. 6, I had "the smile that won't come off," and some of them were considering where they would get the next job at.

The bolt cutter was the next machine to attract attention, as the man running it—although he had grandchildren old enough to sleep alone—could not run both sides on short bolts, and, in fact, it was more than he could do to run the one side properly. The foreman, in talking the matter over with me, spoke of discharging him and putting on another man, but as the old fellow was faithful and tried to do his best, I told the foreman if he would have some sockets made according to my sketches I would guarantee the old fellow would keep up all right. The foreman consented, and I had two sockets of each size made, $3/8 \times 1/2$ and $5/8 \times 3/4$, as per sketch No. 7. A pair of these fastened in the jaws saved a world of trouble and work and was effective on bolts up to 10 ins. long, for all grandpa had to do was to throw the finished bolt out and put a new one in the socket and run it up to the dies and guide it in.

Care should be taken in such a case that the socket have plenty of taper, as the heads of the bolts vary and the sides are not always equal, but by making the socket $1/2$ ins. deep and $1/4$ in. larger at the front and just the size of the head at the back, will give plenty room for variations.

I derived satisfaction from the fact that I had the everlasting gratitude of grandpa, but this was the only case of this kind which was pronounced enough for my observation to discern while there, and I attribute this demonstration of feeling to the fact that a whole lot of manual labor was saved; and I found in that climate the natives could lay down at the side of hard work and go to sleep, which they often did when not closely watched.

It is well to leave the stem on this socket (made of soft steel) large enough to true up in the lathe with a wrought iron plug for the socket so it can be made as straight as possible; this gives perfect alignment when clamped in the machines.

This road built a great many of its own cars at these shops, and used the Wagner flush door, and as there was no means of getting out the eccentric rods except by hand, it kept two fires busy on this item alone, and they were always behind and very often some of the other fires had to help them, and when things came to this pass our foreman, who was

a Frenchman and very excitable, would take turns cussing in French-Creole and English to relieve his feelings, and when he got some of the high pressure worked off in this way he would come and tell his troubles to me, which caused me to put on my thinking cap and by a judicious overhauling of my brain pan, thereby starting in motion a few wheels in that receptacle that had lain dormant for some time, I evolved the following scheme to help matters out and save the State the expense of sending the Frenchman to its institution maintained for brain fag.

To give an idea of the difference in the ways of making these eccentrics, Fig. 8 shows the disk shaped by hand with the teat jumped on, and the back gouged out to weld the stub end of the rod on. Fig. 9 shows the completed eccentric. In my process we had a whole lot of stock to upset, so we used larger iron for the purpose, $1\frac{1}{4}$ in. round by 9 ins. long, one end reduced and offset by hammer dies, as per sketch No. 10. By placing the offsetting arrangement to one end of the dies, as per Fig. 11, I saved a change of dies and allowed us to finish the pieces up as we offset them, and this was a great advantage after we built a small portable coke furnace, which we could use in any part of the shop and get it out of the way when not needed.

The die for shaping the eccentric was made from a soft steel axle, and Fig. 12 shows the bottom part and flat view, Fig. 13 the top part side and flat view, and Fig. 14 the die put together ready for business. The two working faces were case hardened and plenty of taper given the holes and recess so it would release easily when the hot piece began to contract.

Our foreman was on nettles while I was getting this part done, and was very much afraid it would not work, but was worried more about the piece coming out of the die than anything else, and wanted to bet me a new hat the first would stick so tight we would have to cut it out, but by using reamers for the holes and filing off all sharp edges we had no trouble whatever, and with a furnace as mentioned before, were able to finish up from 150 to 200 per day, as against 12 to 15 for the old way for each fire.

I got quite a lot of compliments from the M. C. B. on this job and the foreman was so delighted he treated me to a bottle of home-made wine that made me see stars for a week after I drank it, and put me on to the fact that our foreman's special brand was an excellent thing to let alone if one did not want to be a past master in the art of cursing in three languages in one breath like our man from "Paree."

T. Toor.

Lubricator Incident.

I was running a No. 3 Detroit Lubricator on passenger, 160 miles per day; the steam pipe to lubricator broke, and I was obliged to take it off on the road, and leave at the shops; the shop was in the middle of division. I, of course, had to plug the lubricator at point where steam pipe joined the condensing chamber. It was a couple of days before I got the pipe back, and when I put it up it leaked worse than ever. I took it off and sent it back to shop; in about a week I saw the M. M.; he asked me how I was getting along without that steam pipe. I told him, first rate. I thought I was using less oil than when the pipe was in place. It was about two weeks before it was sent back to me. The cup was a triple feed. I lubricated the air pump, and valves in the usual way, through feed glasses without using hand oilers.

R. J. ELLIOT,
Coast Div., S. P.

Facts About Panama.

Having been a reader of your paper, LOCOMOTIVE ENGINEERING, for several years, and as I have been a resident of Panama for about twenty years, and as I was here during the construction of the canal by French company, a few words might be of benefit to the readers of your journal. The Panama canal is now supposed to be under construction by the American Government. People are coming here from all over the world; a great many from the U. S. A., expecting to find a boom. Engineers, machinists, boiler makers, coming here from the States, expecting to find plenty of work and big wages. They find that there is very little work going on here at present. Those who are working get about half the regular wages paid in the States, 18 to 23 cents an hour for boiler makers, machinists and engineers.

The conditions of living here are much worse than in any part of the U. S. A. The cost of living is high, and the climate one of the worst tropical climates known on the face of the earth. The records of Panama will show in the last twenty years there never has been ten days during that time without cases of yellow fever, besides other malarial fevers and tropical diseases, including smallpox, leprosy and elephantiasis. I would advise all mechanics contemplating coming here to have a "cast iron contract" with parties sending them here in regard to wages and conditions of living. Most of the buildings of the old Panama Canal Company are already overcrowded, and people coming here cannot find decent accommodations.

K. Y. Z.

Panama.

Laying Off Shoes and Wedges.

I noticed an article in RAILWAY AND LOCOMOTIVE ENGINEERING, of October, 1904, in regard to criticism on my method of laying off shoes and wedges, by Mr. E. O. Palmer. Now, if I understand Mr. Palmer rightly on his first criticism, he considers I have fallen short in my explanation, especially in the first part. Mr. Palmer is speaking of the accuracy of the length between centers especially after a frame has been broken and welded again. I was not speaking in particular of laying off frames in my article in the August number. I spoke of laying off the shoes and wedges. But I see the point of criticism in regard to the center behind the main jaw, and I omitted in my article to say that the centers of jaws, whether a frame had been broken or not, should be tried with long trams with the long points to see if they were the same distance apart as the centers of the rods.

I think this explains the trouble in having the centers the proper distance apart. Now, the other point Mr. Palmer criticizes is the placing of the pop mark at the bottom of the shoe where the lines intersect, described from points F and F to point G on drawing. Now, it does not seem any more difficult to me to place a pop where these two lines intersect than it would be to place a pop where the square line on shoe and cross line near top of shoe intersect in the old style way of laying off shoes and wedges. In laying off shoes the old way, after putting pops on main shoe, there is a short line drawn across the shoe on next jaw, the same distance from top and bottom as the two pops on the main shoe are. Now, when the one point of tram is placed into the pop on main shoe and a line scratched next shoe (back or forward) so as to cross the short line—and that is the place to put a pop; now, this is where I don't see that there should be any more difficulty in the plan Mr. Palmer speaks of, that in the place I am just speaking of, as when the lines are drawn across each other a pop is placed as near point of intersection as is possible by the machinist, and then the trams are again used and one point held against the first pop on main shoe and the other point allowed to slip gently into pop made at intersection of lines on the last shoe. Now, in my 15 years' experience taking off overalls, I have noticed several machinists that have not placed a pop at the exact intersection of lines and would draw the pop over a trifle by inclining the center punch and tapping lightly. Now, this same method can be used in the other case by trying point of tram into the pop at the bottom of shoe (as is shown at point G on the drawing), and if found not to be the proper length, draw the pop over until

it is the same distance from point F to G, as it is from the other point, F to G. I hope this explanation will remove the doubt of the accuracy of these points in the mind of Mr. Palmer or any other reader of the RAILWAY AND LOCOMOTIVE ENGINEERING.

JOHN W. PERCY.

South Tacoma, Wash.

Cars Used for Coaling Canal Boats.

I enclose a photograph of a small iron coal "hopper," which, I think, must be the original of all the pressed steel cars. These little cars are running on the Cumberland & Pennsylvania, and are used in coaling canal boats; the boats are run under a bridge and the coal is dumped into them. They (the cars) have three separate compartments, with a bottom dump for each. They look like three hat boxes on a flat car. The underframing is wood, and the only springs they have are big chunks of rubber placed over each equalizer. They were built for the Baltimore & Ohio, and in the early '70's were the only type of coal car the B. & O. had. They are now equipped with self couplers, but the car



CARS FOR COALING CANAL BOATS.

shown in the half-tone appears to have one drawhead pulled out.

I was very much interested in the Long Island locomotive, illustrated in your September issue, and I firmly believe that if 20 years ago, railroads had used suburban engines in suburban service, there would have been less trolley lines in the country to-day.

E. W. GREGORY.

Ridgeley, West Va.

Handling Leaky Engines.

Knowing how to get a leaky engine over the road, with or without a train, has in latter days become a matter of more real practical importance to the engineer than a knowledge of the finer points of valve motion or combustion. The latter are but theoretical problems, while the former is a real, live condition which sometimes tries all the nerve, skill and resource of the engine crew.

In relating experiences with leaky engines we sometimes hear the remark, "I did not have over eighty pounds of steam at any time during the trip," or "I ran her until the pressure was down to sixty pounds, when I stopped to blow up."

That is the wrong way. One should never have to stop for steam unless it is a case of die. Keep the steam pressure at or near the highest point. Stop only for water. High steam pressure is used with greater economy in working the engine, generates more steam than could be possible with lower pressure, because of the greater blast force on fire, and when shut off to gain water the full force of blower serves to keep temperature up while boiler is being refilled.

The process of refilling a boiler having a leaky fire box, with steam pressure down to sixty or eighty pounds is a decidedly slow one, and if an engine can possibly recover from such a condition at all it is pretty good evidence that with proper handling she would do pretty good work.

Of course, judgment must be exercised in making stops to refill boiler so train may be started from that point, or it may be advisable to run a little further even at the expense of steam to make a point where train will run on a favorable grade and water be regained without much loss of headway, and it may be absolutely necessary to run steam down to the lowest in order to keep out of the way of superior trains; but when left to his own choice in the matter, the engineer should be guided by the theory that it is an easy matter to get water when he has steam at high pressure, but a difficult and tedious task to get both water and steam when the pressure is low.

Engines will, of course, die on the road in spite of every effort on the part of the crew, but there is a right and a wrong way to do everything, and the writer believes that if the proper method be followed in handling a leaky engine she may often be brought to the terminal with whole or part of train, when otherwise she might fail completely out on the road.

T. P. WHELAN.

No. 49's Lost Cylinder Head.

In your November, 1904, number, Mr. W. De Sanno claims there is a missing link in the story of the 49 and the lost cylinder head.

I think he has made a mistake in not taking time to reflect on the subject. As the 49 evidently slipped an eccentric on the left side, and as soon as Dan "widened on her," the steam in the cylinder, not being able to raise the valve, has broken the head.

Owing to the area of the valve being about 7 times as large on the top as it is on the bottom, the steam pressure in the cylinder would have to be 7 times greater than it was at the time on the valve to raise it. Hence the broken cylinder head.

JAS. H. STRYKER.

Hibernia, N. J.

The Schenectady Superheater Locomotive.

The American Locomotive Company have brought out a new locomotive superheater, designed by Mr. F. J. Cole, mechanical engineer of the company, and which is known as the "Schenectady" superheater; it has been applied to New York Central Atlantic type (4-4-2) passenger engine 2915, now in regular service on the Mohawk Division, between Albany and Syracuse, N. Y.

The first new feature of construction is in the T-pipe. It is of special design, as shown in Figs. 1, 2, and 4. This T-pipe is subdivided into two compartments by a horizontal partition, and extends nearly across the smoke box; steam entering from the dry pipe is admitted to the upper compartment only. To the front side of the T-pipe are at-

tached eleven header castings; the joints being made with copper wire gaskets; each header casting is also subdivided into two compartments, but in this case by a vertical partition; five pipes or flues of 1 1/16 in. outside diameter are inserted through holes (subsequently closed by plugs) in the front wall of each header casting, these 1 1/16 in. tubes having first been expanded into special plugs, are firmly screwed into the vertical partition wall; these five 1 1/16 in. tubes are inclosed by five 1 3/4 in. tubes, which are expanded into the rear wall of the header casting in the usual way; each nest of two tubes (one 1 1/16 in. and one 1 3/4 in.) is incased by a regular 3 in. boiler tube, which is expanded into the front and back tube sheets as usual; the back end of each 1 1/16 in. tube is left open; the back end of each 1 3/4 in. tube

is closed; the back ends of the two tubes being located at a point about 36 ins. forward from the back flue sheet. The detail arrangement and grouping of the three flues are shown by Fig. 3. The back end of the 1 3/4 in. tube is closed by welding, and the tail is so formed as to support this tube in the upper part of the 3 in. tube, thus leaving a clear space below. Fig. 1 shows that the 1 1/16 in. tubes are concentric with the 1 3/4 in. tubes at their back ends, but the fact is, the 1 1/16 in. tube is allowed to drop and rest on the bottom of the 1 3/4 in. tube, as shown by Fig. 3.

Steam from the dry pipe enters the upper compartment of the T-pipe and thence enters the forward compartments of each of the 11 header castings, and then passes back through each of the 55 1 1/16 in. tubes, thence forward through

er casting, is completely inclosed by metal plates; the lower part of this inclosed box is provided with a damper which is automatic in its action. Whenever the throttle is opened and steam is admitted to the steam chests the piston of the automatic damper cylinder, shown in Fig. 2, is forced upwards, and the damper is held open, but when the throttle is closed the vertical spring immediately back of the automatic damper cylinder brings the damper to its closed position, so that heat is not drawn through the 3 in. tubes when the engine is not using steam. In this way the superheater tubes are effectively prevented from being burned. In introducing the group of 3 in. tubes and applying the superheater, there is a slight loss of heating surface, but it is more than offset as regards

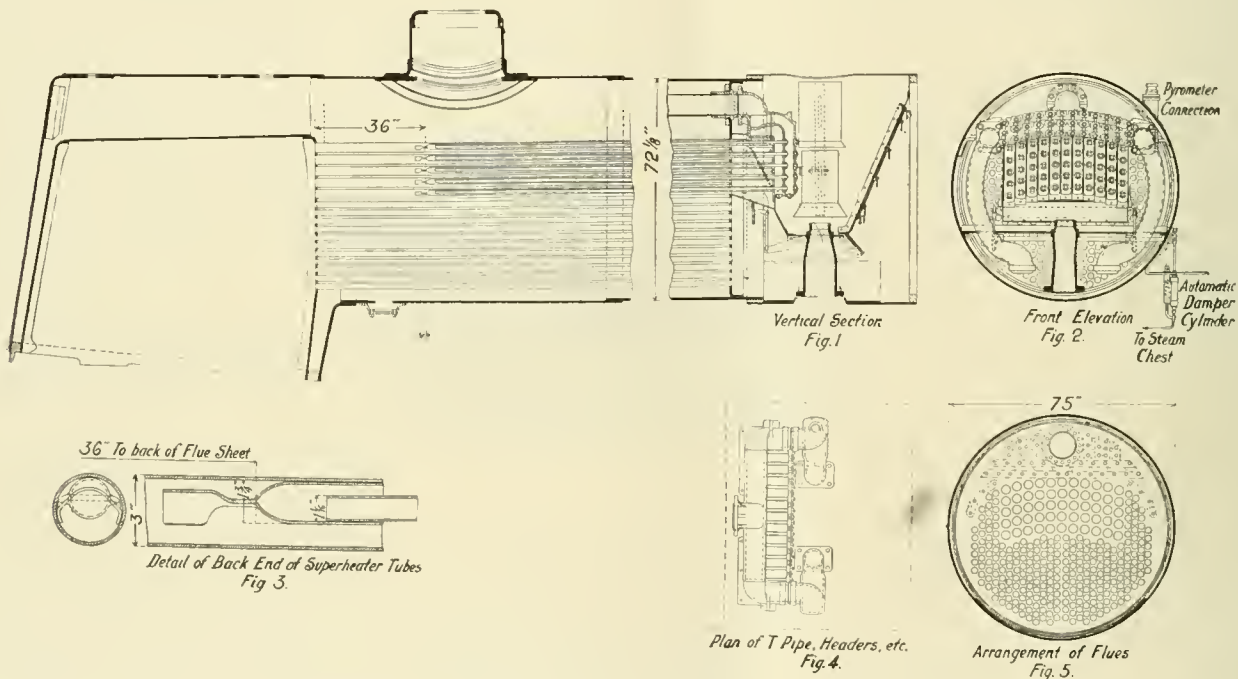

THE SCHENECTADY SUPERHEATER APPLIED TO A LOCOMOTIVE BOILER.

tached eleven header castings; the joints being made with copper wire gaskets; each header casting is also subdivided into two compartments, but in this case by a vertical partition; five pipes or flues of 1 1/16 in. outside diameter are inserted through holes (subsequently closed by plugs) in the front wall of each header casting, these 1 1/16 in. tubes having first been expanded into special plugs, are firmly screwed into the vertical partition wall; these five 1 1/16 in. tubes are inclosed by five 1 3/4 in. tubes, which are expanded into the rear wall of the header casting in the usual way; each nest of two tubes (one 1 1/16 in. and one 1 3/4 in.) is incased by a regular 3 in. boiler tube, which is expanded into the front and back tube sheets as usual; the back end of each 1 1/16 in. tube is left open; the back end of each 1 3/4 in. tube

is closed; the back ends of the two tubes being located at a point about 36 ins. forward from the back flue sheet. The detail arrangement and grouping of the three flues are shown by Fig. 3. The back end of the 1 3/4 in. tube is closed by welding, and the tail is so formed as to support this tube in the upper part of the 3 in. tube, thus leaving a clear space below. Fig. 1 shows that the 1 1/16 in. tubes are concentric with the 1 3/4 in. tubes at their back ends, but the fact is, the 1 1/16 in. tube is allowed to drop and rest on the bottom of the 1 3/4 in. tube, as shown by Fig. 3.

In this case, fifty-five 3 in. tubes are inserted in the upper part of the flue sheets, thus displacing as many of the regular smaller tubes as would occupy the same space, shown by Fig. 5.

In this design the superheater tubes are protected from excessive heat when steam is not passing through them by an automatic damper, as shown in Figs. 1 and 2. That portion of the smoke box below the T-pipe and back of the head-

er casting, is completely inclosed by metal plates; the lower part of this inclosed box is provided with a damper which is automatic in its action.

Whenever the throttle is opened and steam is admitted to the steam chests the piston of the automatic damper cylinder, shown in Fig. 2, is forced upwards, and the damper is held open, but when the throttle is closed the vertical spring immediately back of the automatic damper cylinder brings the damper to its closed position, so that heat is not drawn through the 3 in. tubes when the engine is not using steam. In this way the superheater tubes are effectively prevented from being burned. In introducing the group of 3 in. tubes and applying the superheater, there is a slight loss of heating surface, but it is more than offset as regards

economical results by the superheating process. The application of the superheater reduces the heating surface of the fire tubes by 12.6 per cent., and reduces the total heating surface by 11.9 per cent. The actual superheating surface is 301 sq. ft., which is 10.6 per cent. of the fire tube heating surface, and 9.9 per cent. of the total heating surface of the superheater engine.

A pyrometer is inserted in the left steam pipe, and readings from it show that the average temperature is about 517° F.; the boiler pressure being 200 lbs. per square inch, and the corresponding temperature being 387° F., a superheating of 130° is accomplished. The piston rod metallic packings are made of a special mixture (which, in this particular case is a mixture melt-

ing at about 1,200° F.) in order that they will not be unfavorably affected by the excess heat in the cylinder.

When the superheated steam is used no chances can be taken as regards lubrication of the cylinders, and, therefore, forced feed is resorted to instead of the usual gravity feed. Although the maximum steam temperature is about 517°, as stated, yet the constant temperature of the cylinder walls is probably something above the mean of 517°, and the average temperature (perhaps 230°) of the exhaust; it is, therefore, probable that the constant temperature of the cylinder walls, when steam is being used, is in the neighborhood of 385°, which, however, is considerably higher than the corresponding temperature would be in the case of an engine not equipped with a superheater.

The particular forced feed lubricator which is used in this case is of German make, and embodies four reservoirs which are filled with oil before the he-

wheels 57 ins. in diameter. Eleven-inch inside admission piston valves distribute steam, which has a boiler pressure of 200 lbs.

The weight of this machine in working order is 186,200 lbs., of which 163,675 lbs. rests on the drivers. The calculated tractive effort is about 36,800 lbs. The valve gear is direct motion with transmission bar passing over the second driving axle with double arm, hanging rocker between first and second drivers. All the wheels of this engine are flanged.

The boiler is of the wide fire box type and is radially stayed. It is 69 ins. inside diameter at the smoke box end and the sand box stands on the taper course. There are 244 tubes 2 ins. in diameter and 22 ft. 5 ins. long. The heating surface is made up as follows: 2,216 sq. ft. in the tubes, 165 sq. ft. in the fire box and 280 sq. ft. in the superheater tubes.

The main reservoir is under the running board, which is raised up to carry

Weight of tender, loaded, 130,000 lbs., kind of wheel, cast iron, chilled, double plate, 750 lbs.; dia. and length of journal, M. C. B., 5½x10 ins.; brake beams, "Simplex."

Prizes for Baldwins.

The Baldwin Locomotive Works and their collaborators have received the following prizes: Grand prize for locomotive exhibit. Gold medal for electric locomotives and electric trucks, and one for compressed air locomotives, and another for the Standard Steel Works' exhibit. Mr. William P. Henszey received a gold medal for development and improvements in trailer trucks. Mr. S. M. Vauclain also received a gold medal for development and simplification of the balanced compound locomotive, and Mr. Cornelius Vanderbilt received a gold medal for development of the cylindrical tender.

The Canada Foundry Company, of Toronto, Ont., are building some engines for the Canadian Pacific Railway. This



CANADIAN PACIFIC 2-8-0 WITH SCHMIDT SUPERHEATER.

H. H. Vaughan, Supt. of Motive Power.

Canadian Locomotive Works, Builders

ginning of the run, the oil being forced out of these reservoirs through connecting pipes to the cylinders, by plungers which receive a gradual but constant downward impulse by a screw motion, which is actuated by a system of levers connected with a return crank on one of the rear driving wheels; in this case two oil pipes are led forward from the lubricator to either side of the engine; one of each pair of oil pipes enters the live steam passage through the cylinder saddle, and the other is led directly into the cylinder at the middle of the stroke.

A Canadian Pacific 2-8-0 Engine.

The Canadian Pacific Railway have recently received from the Canadian Locomotive Company, Ltd., of Kingston, Ontario, some heavy consolidation engines, which form the subject of our present illustration. The engines are simple, having cylinders 21x28 ins., and driving

it out of the way. The Ritter oil pump is used, which supplies oil to the valve chamber and direct to the cylinders as well. This pump is driven by an attachment to the crank pin of the left rear driver. The engine is supplied with a Schmidt superheater, and a Crosby vertical reading dial steam gauge is in the cab.

The tender tank is of the U-shaped type with sloping back inside; it contains 5,000 Imperial gallons of water. The coal capacity is 12 tons. The tender frame is made of structural steel and the whole is carried on arch bar trucks with "Simplex" bolsters. A few of the principal dimensions are as follows:

Wheel base of engine, rigid, 15 ft. 10 ins.; total, 24 ft. 4½ ins., and tender, 53 ft. 3¼ ins.; length over all, engine and tender, 63 ft. ¾ in.; width, 10 ft. 1 in.; height, 15 ft. ¾ in.; length of fire box, 96 ins.; width, 65¾ ins.; injectors, Hancock with Sellers' check.

concern has lately been equipped to do this kind of work. No engines have been built in that city for about 40 years. Some of the oldest inhabitants are believed to have seen an engine built in Toronto for the Northern Railway somewhere in the sixties. There are now three locomotive building establishments in Canada. Both the Canadian Pacific and the Grand Trunk Railways have shops suitable for building locomotives, but lately these shops have been almost entirely occupied with repair work.

An enemy can partly ruin a man, but it takes a good-natured injudicious friend to complete the thing and make it perfect.—*Clemens.*

The secret of success is concentration; wherever there has been a great life or a great work, that has gone before.—*Olive Schreiner.*

Railway and Locomotive Engineering

A Practical Journal of Railway Motive Power and Rolling Stock.

Published Monthly by

ANGUS SINCLAIR CO.,

136 Liberty Street, New York.

Telephone, 984 Cortlandt.

Cable Address, "Loceng," N. Y.
Glasgow, "Locauto."

Business Department:

ANGUS SINCLAIR, President.
FRED M. NELLIS, Vice-President.
JAMES R. PATERSON, Sec'y and Treas.

Editorial Department:

ANGUS SINCLAIR, Editor.
F. M. NELLIS,
GEO. S. HODGINS, } Associate Editors.
JOS. A. BAKER,

Advertising Department:

Eastern Representative, S. I. CARPENTER, 170 Summer St., Boston, Mass.

Western Representatives:

JOS. A. BAKER and F. B. LAWSON, 1204 Monadnock Block, Chicago, Ill.

British Representative:

THE LOCOMOTIVE PUBLISHING CO., Ltd., Amen Corner, Paternoster Row, E. C., London.

Glasgow Representative:

A. F. SINCLAIR, 15 Manor Road, Bellahouston, Glasgow.

South African Representative:

E. MILLS, P.O. Box 1477, Cape Town, S.A.

SUBSCRIPTION PRICE.

\$2.00 per year, \$1.00 for six months, postage paid to the United States, Canada and Mexico. For other parts of the world, \$2.50 or ten shillings. Single copies, 20 cents. Remit by Express Money Order, Draft, Post Office Order or Registered Letter. Mailing address can be changed as often as necessary—always give old and new address, and if you subscribed in a club, state who got it up. Please give prompt notice when your paper fails to reach you properly.

Entered at Post Office, New York, as Second-class mail matter.

Copyright by Angus Sinclair Co., 1904.

For Sale by Newsdealers Everywhere.

Merry Christmas to Our Club Raisers.

We desire to call the attention of our club raisers to two important things. The first is, that in order to facilitate business, the names of our subscribers ought to be sent in to us by December 15. When this is done it gives us a chance to get our mailing lists finished in good time to insure early delivery in January. In other words, come early and avoid the rush. We also wish to caution our friends about sending in shop or roundhouse addresses. The home address of each subscriber ought to be used, because when that is done there is less likelihood of the paper going astray, and little or none of it being stolen. We wish our club raisers and friends all kinds of prosperity and a merry Christmas, and if they will look after these little matters for us it will help to give us a merry Christmas.

Demand for Our Correspondence School Course.

The indications are that our Correspondence School is going to be the most popular thing that railway men have made the acquaintance of for many a year. New subscriptions are flooding

our office and nearly everyone asks to commence with the November number, which contains the beginning of the educational course. We increased that issue by three thousand, but it looks as if the supply of that number will be exhausted before the December paper reaches our readers. If the issue should run out prematurely, we will print sheets of the first lesson and send them to those who fail to secure the November number.

Rapid Transit in New York City.

Manhattan Island, on which the main portion of the city of New York is built, is a narrow, rocky ridge, about 13 miles long and scarcely two miles wide. The island is bounded on the west by the Hudson river and on the east by the so-called East river, which in reality is no river at all, but an estuary of the sea, and divides Long Island from the mainland and from Manhattan. The shape of the island, a long, narrow strip, in plan not unlike a banana, makes urban transportation difficult, for a long distance has to be traversed to serve a limited area. The business portion of the city, with the multitude of high buildings, some of which during the day contain people enough to fill a small town, is crowded in the two lower miles of the island, forming a dense population, which has to be moved to and fro every day. Probably 900,000 people have to be transported from the lower three miles of the island every working day and most of the carrying has to be done in three hours, morning and evening. In an ordinary city, the business people are moved radially to and from a center, but in New York City the greater part of them have to be carried along a narrow strip. This distributes the traffic over such a long line that the city has nearly always been behind the demand in facilities of transportation.

As early as 1830 a line of stages was started to run from the Battery to Bleeker street, a distance of about two miles, traversing the town which was then fairly compact. Two years later, in 1832, the first street car line in the world was opened and the appearance of the tiny cars, built by John Stephenson, excited wild enthusiasm among the people—when they first began to run. Street cars had a monopoly of urban transportation until 1867, when the Greenwich Street Elevated Railroad was opened. It was first operated by cable which was soon abandoned for small locomotives.

The Greenwich Street Elevated Railroad was a very ugly and fragile structure, but it carried the passengers much faster than they were moved on the horse cars. The enterprise, however, was the subject of no end of abuse and ridicule, but in spite of that it kept moving its trains with fair regularity and

gave to the people of New York an object lesson of possibilities that might be worked into practice for rapid transit.

The captious critics never ceased to regard the Greenwich Elevated as anything better than an object of mirth and flip-pant jest, but people who had to move faster than the "bob-tail" car, rode on the elevated when possible, and so the common people of New York came to demand that elevated railroads be extended. The people of that city to greatly desire a thing means that it must soon be supplied. The construction of elevated railroads on a large scale went gradually on until the island was traversed part of its length by four lines and part by three, making an aggregate of about 37 miles.

The elevated railroads of New York were admirably operated for long years by small steam locomotives, and latterly by electricity; but they seemed always to be behind the requirements during rush hours. The trains were so timed that one train was entering a station as the preceding one was leaving, which is performing the maximum service; but they never of late years carried the passengers without excessive crowding. The people in no city in the world are so exacting with public services as the people of New York, and there was always abuse of the management of the elevated railroads, just as it had been with the poor Greenwich line. While these railways continued year after year carrying in absolute safety and with fair expedition, the largest number of passengers per mile in the world, the newspapers and people of the city never ceased their denunciations of how badly the work was done.

After all the elevated railways were in operation increased urban and suburban facilities were still really urgently needed, for besides the increase of people annually added to the population, there was found to be a growing increase in the car rides taken per individual. This may be accounted for in several ways—the increase in the number of people who can afford to ride, in the cultivation of the taste for riding in cars, in the growing distaste for walking, and in homes being pushed further away from the places of business. Be the cause what it may, the number of rides taken by each person is steadily increasing. Statisticians say that while in 1860 the average number of rides per capita, in what is the Borough of Manhattan, was only 47, in 1880 it had risen to 182, in 1900 to 388, and in 1903 to 418. This would indicate the growing need of much greater facilities for urban transportation than what would be naturally called for by the increase of population.

About fifteen years ago an active agitation began to take form in favor of construction of a system of underground

railways for Manhattan. After five years' discussion of some impracticable moves, the scheme took shape in 1894 by the creation of a Rapid Transit Commission, the members of which were authorized to sell a franchise to a private corporation, or to engage in construction by the city as the people might decide. They decided for city construction and contracts were awarded to the famous contractor, Mr. John B. McDonald, to build and equip the lines which have popularly become known as the "Subway." The main line, as planned, will be seven miles long, with two branches each of seven miles. This involves the excavating of 1,700,228 cubic yards of earth and 773,093 to be filled back, 921,128 of rock to be excavated, and 368,606 yards to be tunneled. The steel to be used in the construction was reckoned at 65,044 tons, the cast iron at 7,901 tons, concrete 489,122 cubic yards, brick 18,519 cubic yards. These seem to be abstract figures, difficult for the imagination to grasp, but they represent stupendous operations, an important part of which has been carried out with surprising expedition. A great part of the excavation and all the tunneling completed was done through tough gneiss rock, and the operations were complicated by sewers, water mains, gas and steam pipes, and a labyrinth of other obstructions that had to be maintained intact. It was necessary at times to depress the tunnels from 60 to 70 ft. below the surface, and long stretches of the finished roadway are run along that depth.

To the ordinary reader a yard of material is a very vague quantity. It may appeal better to many of our readers when we say that every cubic yard of the rock material excavated weighed over 5,000 lbs. Between excavating and tunneling the contract calls for the movement of 1,289,734 cubic yards of rock, which would weigh over 3,225,000 tons. That would make a load of 3,000 tons each for 1,612 trains.

The first nine miles of the Subway were opened for business last month and began at once to carry immense loads of passengers. There are four tracks, all operated by electrically driven trains, equipped with every approved device for promoting safety and comfort of patrons. The signal system by which trains are protected is the most perfect arrangement that human ingenuity has yet devised for that purpose. Two of the tracks are used for local service trains and the other two for express trains. The speed maintained by the latter is about 40 miles an hour, so the city has been provided with rapid transit such as no other city in the world enjoys.

The opening of this system of rapid

transportation was for months awaited with the most pleasing anticipations, but no sooner was it realized that the beneficiaries proceeded to find causes for discontent. Within a short week after the opening, the Subway monopolized the attention of all the cranks and fault-finders in the metropolis as an object of splenetic scolding. The first discovery alleged to be made was that the atmosphere of the Subway was deficient in oxygen. Then the noise was magnified into something destructive of all human nerves. Others predicted the production of a grievous optic malady, called the "Subway eye," which would be brought about by the flutter of light on the numerous steel posts which carried the roof of the tunnel and which were painted white, and, finally, the microbe crank has found the lines a fertile breeding place for death dealing germs. If some of the writers on the Subway were taken seriously it would mean that this hole in the ground is the most dangerous channel to destruction that a confiding public was ever invited to enter. In reading over the reverberations concerning the shortcomings of the Subway, we have wished that the writers, along with the microbe fiends, could be condemned to spend an entire week riding in the stifling atmosphere of the steam operated London Underground railways.

The Modern Fireman.

A subject discussed at the recent convention of the Traveling Engineers' Association, and one which has already assumed considerable importance, is that of selection of men for locomotive firemen. The conditions environing this subject have so changed during the past several years that it is necessary to have an entirely different consideration of the problem. Then there were small engines, and a man of ordinary physique was able to shovel the amount of coal required by the engine in the performance of its work. Now, the engines of the "hog" and "battleship" classes are much heavier and consume much more coal than did the lighter eight-wheel "American" type engines, requiring a man of much sturdier physique than formerly.

The chief disconcerting feature of the problem is to procure a man who will be sufficiently muscled to withstand the heavy manual labor at present imposed upon the fireman of the modern mastodontic locomotive, and who at the same time possesses the mental caliber for locomotive engineer duty when his time comes for promotion. This ideal specimen of modern fireman must be a man to whom nature has been unusually kind in her endowment of both physical and mental strength. This

particular combination is distressingly rare; hence, this troublesome feature of the problem.

It has been said, and with much reason, too, that the ideal modern fireman is a man who is "strong in the back and weak in the head." This combination might do where the man intends only to be and always remain an automaton, merely transferring coal from the tender to the fire box during his period of firing. In this, no intelligence and physical strength only, is required. But this man, possessing only the physical qualification, could never become an intelligent engineer. We must consider that the fireman must some day become the engineer and that he must then have the intelligence required of an engineer. If it were possible to have a man liberally muscular during his period as fireman and then, when we wished, to suddenly transform his muscular developments into mental, we could have the ideal man; but unfortunately, we cannot do this.

At this stage a thoughtful consideration of the mechanical stoker seems to be the most favorable direction in which to seek a solution of the problem. The mechanical stoker looks reasonable for locomotive service. It is operated successfully and economically on stationary plants, and it seems that only mechanical development is needed to fit it to locomotive service. If the mechanical stoker can be made to perform the hard labor of shoveling coal from the tender to the fire box, then the operator can be a man of ordinary physique and intellectual attainments, such as will permit him to operate his machine and also to perform an engineer's duty when promoted to the right side. The problem can be solved, but to do it we may have to bring in an iron back-boned machine from the outside to complete the combination demanded in the modern fireman.

The Voice of a Sensational Eye Doctor.

There was a very sensational paper, prepared by Dr. Nelson M. Black, of Milwaukee, read at a recent meeting of the Western Railway Club, which may exercise a very embarrassing effect upon the prospects of many persons now in the employment of railroads, unless the officials concerned regard the paper at its real value, as a hysterical attempt of an amateur to pose as an authority on questions that experienced railroad men handle with diffidence, the old story of fools rush in where angels fear to tread. The subject was, "Vision of Enginemen and Firemen in Railway Service: Some Facts Affecting the Same."

Three paragraphs from the introduction to the paper will give our readers

an idea of the tone that follows. Dr. Black began:

"But few of the thousands who daily travel over the railroads of the United States in the easy riding Pullmans of our limited trains, have any idea upon what their safety depends in maintaining such a rate of speed. If the traveling public were aroused from their state of blissful ignorance by a knowledge of the existing conditions, a higher standard would be required and absolute uniformity in every department of railroading be demanded by a thoroughly incensed people and enforced by legislative means. Thus, greater protection would be secured and the danger to life and property decidedly diminished.

The frightful railroad wrecks of this year and the appalling number of killed and injured, as reported by the Interstate Commerce Committee, will, if compared with the reports from other countries (England and Germany especially), lead the most fair-minded to the conclusion that something is radically wrong with our railroad systems—their management, equipment, maintenance, employees or discipline.

"It is impossible for one person to analyze the many causes for such a number of injured and the awful loss of life and property, but when it is remembered that to protect space and control the trains of a railroad system, various methods of signaling are used, *the visual requirements of employees actively engaged in operating trains, or giving and taking signals, is of no small importance.*"

Dr. Black is evidently an ophthalmist or specialist on eyesight, and he obtained permission to ride on locomotives so that he might have the opportunity of studying directly the exertions imposed upon the vision of enginemen during the arduous work to guiding fast trains over a railway in all conditions of service and weather. The opening of his paper leads the reader to suppose that he intends discussing particulars of all the causes that lead to "frightful railroad wrecks," but he confines himself exclusively to the necessity for enginemen possessing very good vision and his limited experience magnified the difficulties which trainmen labor under in identifying signals.

A novice to the locomotive cab is not a fit judge of the real difficulties encountered by the men in charge of the engine especially at night; nor is he in a position to judge of the mental control which trained men have over every detail by which their work is regulated. What to a novice seems a series of exciting episodes, is to the trained man events of regularly controlled matter of fact duties. A trip which a stranger finds full of terrors is to the enginemen commonplace experience. The fitful glare from the fire box door, the shriek

of passing trains, the confusing flashes from stationary signals and switch lamps are bewildering to people who have not received the training that brings confidence and mastery; yet the novice, who seems to have been appalled by his experience under such conditions, sets himself as a judge of what ought to be done to reduce dangers of train operating.

There are many improvements which might be carried out that would promote the safety of train operating on some railroads. Proper block signals are badly needed on many railroads, and many of those in use are badly located for being easily seen. Train dispatching in many quarters is far from being perfect, and much carelessness prevails concerning the protection of trains. The open switch is a mighty menace that has slain its thousands and protection from washouts and accidental obstructions is painfully defective. Yet this Dr. Black, who rushes before railroad men as a mentor on prevention of accidents, ignores all these things and urges increase of the inquisitorial system on the vision of enginemen, although there is no evidence that any of the "frightful railroad wrecks" was due to the defective vision of any railroad man. That is his whole panacea for preventing railway accidents. He conceived an elephant and brought forth a mouse.

The evident purpose of Dr. Black's paper is to magnify the services of the ophthalmist or eye specialist, and to throw more work into his hands by requiring railroad men to have their vision inspected much more frequently than has been the custom on railroads that are the most exacting for good eyesight. It is highly important that enginemen should have good eyesight, but the agitation for vision inspection and supervision has been greatly overdone and Dr. Black is merely bestirring himself to attach his exaggerated notions upon an already overloaded kite. He may safely leave supervision of the eyesight of their employees to railway officials.

Our Collection of Railway Antiquities.

We understand that the splendid collection of railway historical antiquities, which Major Pangborn has collected, is going begging for a home. The collection was made originally for the Baltimore & Ohio Railroad exhibit at the World's Fair in Chicago, and it has received important additions for installation at the St. Louis exhibition. The collection was stored since 1893 in the Field Museum in Chicago, but it seems that the management of that institution do not want the railway antiquities any longer, although they were the most popular and attractive feature of the Field Museum. The Field Museum people have become so attached to pure science and its refined manifestations that they

no longer care to supply housing for articles connected with applied mechanics.

Major Pangborn has been striving to find a home for the exhibit where its historical value would be appreciated, and the city authorities of Philadelphia have agreed to furnish storage space in a public building. That is a good beginning, but it is necessary to raise funds for maintaining the exhibit in good order and for purchasing additions. We understand that certain railway companies have agreed to contribute to such a fund, but it is a matter which ought to be cared for by the United States Government. It is the best collection of railway antiquities in the world and the value of the articles will increase as years roll by. The British Government maintains a splendid collection of mechanical antiquities in South Kensington Museum, London, and we have no doubt that they would make a high bid for the collection that Major Pangborn has charge of, but this country ought to have too much pride in the possession to let them go.

Harvest from Seeds of Kindness.

In Egypt the husbandmen sow seed upon the flooded water of the Nile as it stands over their land. The grain sinks into the wet soil and germinates in due season. That practice gave origin to the saying, "Cast thy bread upon the waters and thou shalt find it after many days." The modern application of the idea is, "Scatter seeds of kindness."

At the Presidential election Eugene V. Debs received some 600,000 votes for President, representing the Socialist party. We have been informed that a very considerable part of Mr. Debs' support came from railway men, being a harvest of votes rising from long-sown seed. Years ago when the Brotherhood of Locomotive Firemen was in such a struggling condition that its days seemed numbered, Eugene V. Debs became secretary, and in his efforts to keep life in the organization, he prevailed upon his father to mortgage his farm to raise money needed for urgent current expenses of the Brotherhood. By untiring energy Mr. Debs put new life into the organization, and in co-operation with Frank P. Sargent and other kindred spirits, made it one of the best and most powerful labor unions in the world. The personal magnetism of Mr. Debs contributed greatly to combining the members and to drawing in new adherents. While he remained a leader of the Firemen's Brotherhood his voice and counsel always favored moderation and fair dealing, which brought the organization into popularity with railroad officials.

The progressive and radical tendencies of Mr. Debs' mind carried him away be-

yond his fellows and landed him into the Socialist camp, where he was lately the standard bearer. We do not think that he has carried many railroad men along with him, but thousands were ready to give him their vote as a compliment to his genial personality and in remembrance of what he did for the Firemen's Brotherhood.

Socialism represents the idea of all efforts being devoted to benefiting the masses instead of furthering the individual interests. The late Mark Hanna believed, and many other far-seeing people believe, that in the near future the Socialist party will take the place of the Democratic party and that future political contests will have the Republican party representing capital on the one hand, and the Socialist party representing the interests of the masses on the other. Should that come true, Eugene V. Debs may yet be one of the most important personages in this nation.

Term Locomotive Engineer.

There is an idiotic species of writers on railroad subjects, some of them editors of railway journals, who express themselves as if they had never heard of a locomotive engineer. Their pens move with contempt and anger when the suggestion is made that men who manage locomotives have the right to be called engineers. The snob writers mention enginemen, runners and engine drivers, but never locomotive engineers. They shudder to call anyone an engineer who does not carry a college graduate's diploma in his pocket. Moved by this snobbish sentiment, some railroad companies call their engineers "enginemen," but it does not appeal to the public taste. The American public has decided that the title of the man running is engineer and nothing that envy or petty jealousy can do will ever take that appellation away from the popular tongue.

Book Review.

Mechanical Appliances, Mechanical Movements and Novelties of Construction. By Gardner D. Hiscox, M.E. Publishers, the Norman W. Henley Publishing Company, New York. 1904. Price, \$3.00.

This book is a supplementary volume to the author's work entitled "Mechanical Movements, Powers and Devices," which has already passed through ten editions. The present book is practically an encyclopedia of mechanical movements and mechanical appliances, including many novelties of construction used in the practical operation of the arts, manufactures and in engineering.

The machines incorporated cover a large field and have been carefully selected so as to supply the needs of the

student seeking general information. They will be found representative of the power devices used in old and modern industries.

Although the author has not the slightest desire to encourage the hopeless pursuit of perpetual motion, he has, nevertheless, thought it advisable to dwell at some length on the exceedingly ingenious means devised by misguided inventors in their endeavors to solve an unsolvable problem. The pages in which perpetual motion machines are described may induce those who still believe in this will-o'-the-wisp to bend their energies to ends more worthy of their zeal. It may be that some of the mechanical movements which have been evolved by the perpetual motion inventor, although they did not attain the end sought by him, may still be applied with profit to his instruction in true mechanical principles.

The book is designed for engineers, draughtsmen, inventors and, indeed, all who are in any way interested in the study of mechanical movements.

Locomotive Operation. By G. R. Henderson. Publishers, *The Railway Age*, Chicago. 1904. Price, \$3.50.

This book, of 528 pages, has been written as the preface tells us, with the object of giving a complete and systematic discussion of the theory and practice of locomotive operation. It is divided into nine chapters and is well illustrated throughout with numerous exceedingly clear line cuts, tables and reproductions of carefully plotted curves and diagrams.

It is the purpose of the book to make the points brought out equally available for the university, draughting room or the superintendent or maintenance of way official's office. This book will be found useful to those who have a working knowledge of higher mathematics.

The printing is excellent and nothing is left to be desired about the arrangement of the subject matter of the book.

Proceedings for 1903 of the M. C. B. Association.

The thirty-eighth volume of the proceedings of the Master Car Builders' Association has come from the press. It, of course, contains the proceedings for 1904, and is a standard size book of 584 pages. There were, counting the report of the secretary and of the treasurer, about twenty-five reports in all, presented at the last meeting in Saratoga, and the discussion following is given in each case.

At the back of the book are printed a list of the standards and recommended practice of the Association, also general questions regarding the use of the air brake and train air signal. The rules for loading long material on open cars is given, and the safety appliance acts

are printed for reference. A series of line engravings, to scale, giving figured details of standard parts, and recommended practice is appended.

The proceedings in book form are printed so as to conform in size and appearance with that of the Master Mechanics' Association. It can be had from the secretary of the Association, Mr. Joseph W. Taylor, 658 Rookery Building, Chicago, Ill.

The American Railway Association, which is composed principally of the higher railway officials, has adopted a rule requiring that all applicants for positions in train or station service be required to pass a rigid physical examination. Quite a number of railway companies already have that practice in force and in some cases the men are subjected to periodical examinations, which is done for the purpose of detecting any disease which might prove dangerous.

An informal test of the electric locomotive to be used in terminal service by the New York Central was made recently at Schenectady in presence of the officials of the railroad and of the builders. Everything turned out very satisfactorily, the locomotive attaining a speed of sixty miles an hour over the four miles of track which had been selected for the test. A crowd gathered at the sub-station to witness the trial and loudly cheered those on the flying electric machine. The locomotive was built by the American Locomotive Company and the electric equipment was furnished by the General Electric Company.

There is a popular belief among the few people who have paid any attention to railway history that in the days when our people began to build locomotives that Stephenson's Rocket was the most popular engine for imitation. Yet in the year 1832, when Mathias Baldwin built his first engine, the *Railroad Journal* was started and the publishers put an engraving of Ericsson's "Novelty" on top of the front page.

A correspondent writing from Peru to order some of our books on engineering subjects, gives some information about his surroundings; he says: "I am working on the greatest road in the world. We get up to an elevation of nearly 16,000 ft.; there are 58 tunnels and 8 switchbacks on the line. The road is 222 kilometers long (about 138 miles). We have Baldwin and Rogers engines of about 90 tons. There are several Americans running here."

Such as everyone is inwardly, so he judges outwardly.—*Thomas à Kempis.*

Elbow Grease Saved.

An ingenious adaptation of air to save muscular exertion has been made in the McKees Rocks shops of the Pittsburgh & Lake Erie Railroad. In one corner of the tool room, which is really an area

predicted from the use of grease has not materialized. There is also an entire absence of pounds of any description about the engine, which fact speaks volumes for the crews in charge. Although the engine is doubled crewed, no failure of any kind has been recorded against either crew since the engine was assigned to them on this run.

is brought on the scene and it can be kept in use as long or as short a time as is necessary. By its use the metal is always hot and there is no running backward and forward between the shop and the foundry, as the hot metal is right on the ground all the time.

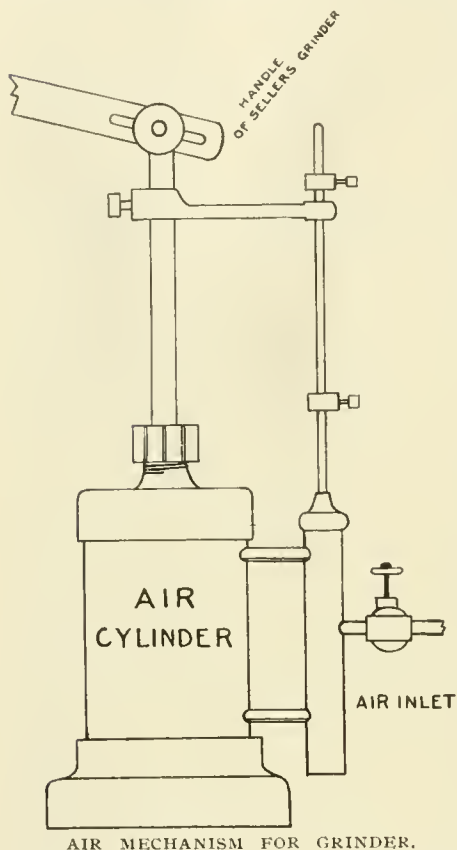

AIR MECHANISM FOR GRINDER.

partitioned off, they have a Seller's tool grinder, and, to the handle, which the operator uses to turn the tool on the emery wheel, there has been attached a modest upright air cylinder with piston valves and tapet valve gear.

When this little air machine is set in motion it moves the handle up and down with more regularity than a man would do it, and with far more solemnity, but it accomplishes its purpose and turns out a good job. It is appreciated in the shop for its readiness to lend a helping hand when tools have to be ground.

The idea is not new by any means, though this particular machine is shop-made and the idea is all right. Many church organs have their bellows blown by similarly designed hydraulic motors.

Enviably Record.

Engine 366, pulling the Knickerbocker Special, one of the limited trains on the Big Four, between Indianapolis and St. Louis, has a remarkable record. Since the grease cellars were applied six months ago, this engine, doubling the road every day, has made over 50,000 miles without any attention to the cellars, and the unusual wear to the brasses

Portable Bronze Furnace.

Our illustration shows the outlines of a portable furnace which is used in the Allegheny shops of the Pennsylvania Lines West of Pittsburgh. It is intended to hold a crucible for melting babbitt metal or bronze for use in the shop, and it is much more convenient and safe than the old way of carrying the heated crucible full of molten metal through the shop.

The furnace is made of $\frac{3}{8}$ in. sheet iron and is 30 ins. in diameter outside; it is lined with 4 in. firebrick, which leaves a circular space 22 ins. in diameter for the crucible. The furnace is carried in a frame mounted upon a pair of broad tread wheels and a suitable handle is provided wherewith to draw it from place to place. The top of the furnace is cone shaped and is lined with firebrick. The cone shaped top is surrounded top and bottom with two substantial wrought iron bands; these bands are secured to a shouldered upright post which acts as a pivot as well. By means of a lever the post may be made to slide up a short distance and so lift the conical top off the furnace body. When lifted clear the whole top can be swung round with the post as a center, and this en-

Responsibility of Deadheads.

Many railroad companies have been in the habit of requiring people who accepted free passes to sign a contract relieving the company from responsibility for damages in case of accident. This was done, although the courts had repeatedly decided that such a contract was not binding on the grounds that no person had the right to contract with a company to permit it to kill or injure him or her without penalty.

Railroad companies accepted that decision of the lower courts for many years without appeal, but lately they have pushed a test case to the Supreme Court and won. The highest tribunal of the land has decided in favor of the railroads, on the ground that a man can contract any hazardous risk if he so desires, and that if he is killed he has only himself to blame for running the risk.

A prominent railroad official, who was interviewed about the decision, said:

"Dozens of people will risk their lives every day on a railroad pass if they can only secure one. These people are the ones who pay for their tickets out of their own pockets.

"But commercial travelers, theatrical advance agents and other people who are sent on the road by big firms, don't want passes now. Some big shipping firms can secure transportation for their employees, but they cannot force the employees to use the passes. The employees argue that in case they are injured they would not be able to recover damages from their own firms, and to use the pass relieves the railroad from responsibility.

"Theatrical advance agents who travel ahead of large companies have always heretofore received passes from the railroads. But they will not use them now, because they have the privilege of buying tickets at regular rates and charging the items in their expense accounts. Many other classes of travelers now refuse to use passes when they can secure them for the asking.

"The decision of the Supreme Court not only will save the railroads immense sums that otherwise would have been paid out in damage suits, but will be the means of increasing the revenues of the companies considerably because of these timid people who would rather pay full fare than ride on a pass."

Those who bring sunshine to the lives of others cannot keep it from themselves. —J. M. Barrie.

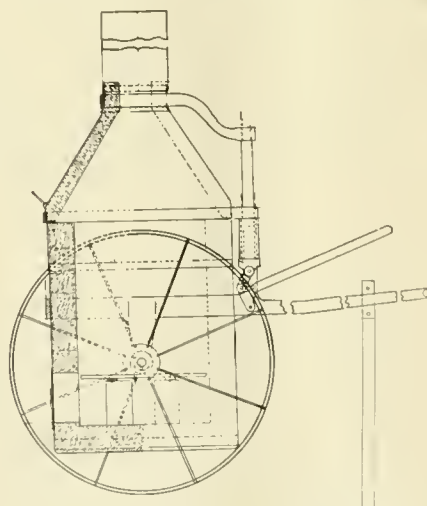

PORTABLE FURNACE FOR BRONZE OR BABBITT.

ables the crucible to be placed in or removed as occasion requires.

The officials of the shop speak in high terms of praise of this shop appliance as a time saver and as the safest way to do the work. When hub liners have to be cast on a pair of wheels, the furnace

Our Correspondence School.

In this department we propose giving the information that will enable trainmen to pass the examinations they are subjected to before being promoted. If any of our students fail to understand any part of the instructions, we will gladly try to make them plainer if they write to us. When a student wishes to receive a private answer, he is reminded that it is usual to send a stamped envelope for the return letter. We will be glad to answer any question relating to railway matters, but prefer that they be suitable for our question and answer department. All letters intended for Our Correspondence School ought to be addressed to Department E.

Making the Best of Our Lessons.

One of the commonest complaints made in the past by people who have conducted correspondence schools, has been that there is great difficulty in prevailing upon those who have paid for a course to study their lessons. In this regard all we can say is that the men who neglect to give the lessons careful study stand in their own light. Railway companies are insisting on their employees possessing a certain grade of knowledge relating to the details of their business, and those who fail to acquire this knowledge are certain to fall behind in the race for good positions.

As a preliminary to studying the lessons, a student would do well to read carefully one or more of the good treatises on the locomotive that can be bought cheaply. That done he should take the questions and study one at a time until it is thoroughly understood, and write out what he supposes to be the correct answer. That he can then compare with the answers given in our course.

In studying the lessons the learner ought not to attempt to memorize the answers. He should merely use the answers as a key to check the answers which he might make up for himself. In studying the questions the student would often find it an advantage to be on or about a locomotive, carefully examining the parts under consideration. If it is not convenient to be about a locomotive, our educational chart No. 7 and valve motion model will be a great help.

Following a system of this kind will instruct a student more thoroughly than attempting to memorize our answers.

If any part of the answers is not understood we will gladly answer letters asking for more information, and the writers need not be afraid that their names will be revealed.

When the course is sufficiently advanced we will arrange to hold examinations in leading cities, with a view to helping our students. Since we announced these lessons, we have received particulars of several cases where men were called up quite lately to be examined for promotion, and the greater part failed. This resulted in the unfortunates having their examination put back six months. Men who test themselves by attending our examina-

tions will have their deficiencies shown at once, and if they are not likely to pass the official examination, they can get to work immediately to learn the things they are weak on without waiting six months.

Questions Continued.

38. Why is it necessary to keep the cylinders free from water?

39. Where is piston rod packing located? Cylinder packing?

40. How are the metallic packing rings on valve stems and piston rods usually held in place? And what provision is made for the uneven movement of the rods?

41. What is the cause of tank sweating? And what will prevent it?

42. What is friction?

43. Upon what does the amount of friction depend?

44. What is the effect of the introduction of oil or other lubricants between frictional parts?

45. Explain the principle on which grease cups operate. What is the objection is using water on a hot pin where grease is used, or a hot pin with babitted brasses?

46. Explain the construction and operation of the blow-off cock?

47. Describe a bell ringer; and how may it be adjusted?

48. How should the blower be used when an engine is on the cinder pit?

49. In case the locomotive in your care became disabled on the road what should you do?

50. Suppose a wash-out plug blew out, or a blow-off cock broke off or would not close, what should be done?

51. What should be done, should the grates be burned out, or broken while on the road?

52. What precaution should be taken to prevent locomotives throwing fire?

53. What should be done with a badly leaking, or bursted tube?

54. Suppose that, immediately after closing the throttle, the water disappeared from the water gauge glass, what should be done?

55. What should be done in case a throttle stem becomes disconnected while the throttle valve is closed; and if it becomes disconnected while the throttle valve is open?

56. In the event of a slide valve yoke or stem becoming broken inside of the

steam chest, how can the breakage be located?

57. After locating a breakage of this kind how should one proceed to put the engine in safe running order?

58. If a slide valve is broken what can be done to run the engine on one side?

59. What should be done in case of link saddle pin breaking?

60. With one link blocked up, what must be guarded against?

61. How can it be known if the eccentric has slipped?

62. Having determined which eccentric has slipped, how should be reset?

63. What should be done in case of a broken eccentric strap or rod?

64. How should the engine be disconnected if a lower rocker arm becomes broken? If a link block pin?

Answers Continued.

BY JOSEPH A. BAKER.

38. To prevent rupture of cylinder and head which would necessarily occur should much water remain after the valve had closed all communication and the piston been forced to the end of its stroke.

39. The piston rod packing is located in the back cylinder head.

Cylinder packing is to be found in the grooved receptacles provided for that purpose in the circular surface of the piston.

40. Metallic packing rings are held in place by stiffened spiral springs pressing against a ring and forcing the packing into a bell-shaped cone.

Suitable provision is made for the uneven movement of the rods in that the cone holding the metallic packing has a ground and steam tight joint, which permits the cone to have a lateral motion against the face of the packing gland, and thereby prevents the escape of any steam.

41. Variations of atmospheric conditions. The temperature of the water in tank being of either a lower or higher degree than that of the surrounding atmosphere, condensation from the moisture in the air takes place on the exterior of the tank.

It can be prevented by bringing the water in the tank to the same temperature as the surrounding atmosphere.

42. Friction is the resistance between two bodies in contact, which resists the sliding of one upon the other.

43. The amount of friction between two bodies in contact depends on pres-

sure, temperature, speed, kind of material and quantity and quality of lubricant.

44. It reduces friction in proportion to the quantity and quality of lubricant used.

45. The principle on which grease cups operate is that of compression and expansion. As grease reduces friction less rapidly than oil, a certain amount of heat is generated, and as grease expands more rapidly than metal, it is forced through the aperture in the cup down upon the pin.

As one of the ingredients of "rod grease" is lye, and as lye will freely dissolve in water, the application of water to a pin will remove the "grease" and destroy lubrication.

The intermittent use of water on hot pins provided with babbitted brasses where oil is used as a lubricant has a tendency to clog the feeder with babbitt metal, thereby preventing the flow of oil to the pin. It also produces unequal contraction of the pin, often with disastrous results. There can be no bad effect from the continuous use of water, if used before the brass becomes overheated and the babbitt starts to melt.

46. A blow-off cock may be either a globe valve operated by a screw, a taper plug valve operated by a lever, a sliding disk valve operated by a lever, or a plunger valve upon whose upper end either steam or air may be forced to unseat it.

The object of any of these valves when open is to permit the escape of sediment and impurities from the boiler, and for that reason they are located at the bottom of the boiler.

47. The automatic bell ringer is a device whose mechanism consists of a valve having either a sliding or rotary movement and provided with a suitable admission and exhaust port, a piston operated in a cylinder, and a piston rod connected to the bell crank so as to impart a swinging movement. The motive power is air taken from the main reservoir.

Some types are provided with a threaded stem and a jam nut by which adjustment can be made, while others have a piston rod operating like a telescope and requiring no adjustment.

48. The blower should be used with just enough force while cleaning the fire to prevent the escape of gases from the fire door and possible injury to the fire cleaner.

49. First, protect the train front and rear by flags the prescribed distance. Make such temporary repairs as are necessary to get the train to the next siding, in order to prevent blockading of the main line. When on the siding make all the repairs practicable with the tools at hand. If the breakdown is of such a nature as to prevent the possibility of making even temporary repairs, so as to clear the main lines, arrange to notify

the nearest telegraph office of your location and ask for assistance.

50. Draw the fire at once to prevent burning of fire box sheets. In addition to this, in cold, freezing weather, the pet cocks on all connections where there is any liability of water collecting should be opened to drain the pipes, and in the absence of cocks the couplings should be slacked off. The tender hose couplings should be disconnected and special care should be given to the air pump drain cocks to prevent the rupture of the steam cylinder of pump.

51. Block up the broken or burnt grates with fishplates, brick, or anything conveniently at hand, and disconnect the good grate immediately ahead and back of the burnt section in order to prevent disturbing the other grates when shacking down fire.

52. In order to prevent engines from throwing fire the netting in the smoke arch must be carefully looked after, and the cinder slide and hand-hole plates must be in their proper places and securely fastened. Equally important is the knowledge that the ash pan is clean, otherwise live coals, more dangerous than cinders, will roll out of the pan and start fires on bridges and along the company's property.

53. Where time and conditions permit, burst flues can be put in condition to bring in train. First, fill the boiler as full of water as it will hold, to compensate for loss. Then blow off steam through the whistle or remove release valve from chest, open the throttle, and blow off steam and deaden the fire so that the flue can be plugged. If the flue is burst, it must be plugged at both ends. If it is simply a case of leaky flue at flue sheet, the above method is not necessary. Simply plug the flue. Bran or any starchy substance admitted through the heater cock on injector after injector has been started will aid in stopping a bad leak.

54. Disappearance of water from water glass may be caused in various ways. The water may be bad and foamy, or the engine may have insufficient steam space, thus causing the water to prime, or the engineman may have taken too many chances on low water. As soon as the water disappears from the glass no time should be lost before banking or deadening the fire. Injectors should be kept at work until the water reappears in the glass before fire is rekindled.

55. With a disconnected throttle closed—where the company requires the engineman to make repairs—steam must first be blown off and the dome cap raised to reach the disconnected rod. Not enough power can be had from the oil pipes to move the modern engine. If she is equipped with a drifting valve, she can be made to move herself without train.

If the throttle is disconnected and open, reduce pressure to a point where engine will not slip, and control the train by air brake.

What is often mistaken for a disconnected throttle is merely a stuck throttle due to excessive lost motion of parts and occurs when giving full throttle. Tapping the throttle rod often releases it from sticking.

56. After satisfying myself that the eccentrics and visible parts of the valve motion were intact, I should consider the type of valve on the engine. With a broken valve stem or yoke, the valve is always forced to the forward end of chest. With an outside admission piston valve or a slide valve, place the lever in the forward gear and watch the steam leaving the cylinder cocks. Reverse the lever, and if the steam issues from both cocks on one side and from only the back one on the other, the latter has the disabled valve.

With the inside admission, steam would issue from the front and not from the back cylinder cock. Where relief valves are used I would remove them first and watch movement of valve.

57. If the engine had relief valves on front end of chest, disconnect valve rod; and, after forcing valve to central position to cover ports, clamp stem from one end and block with a plug driven into relief valve of sufficient length to hold valve in place, leave up main rod and proceed. If relief valve were on back end, the chest cover would not have to be taken up, but back end of main rod would have to be disconnected and crosshead blocked ahead. The disconnected valve rod would hold the valve against forward end of chest.

58. If it is a balanced valve and broken so that the steam ports cannot be successfully covered, slip a heavy piece of sheet iron between valve and valve seat, and block valve front and aft. The balance plate will then come down solid on valve and prevent leakage to cylinder.

With the ordinary slide valve and similar conditions, remove valve entirely and block with hard wood having the grain of the wood crosswise of the seat. With the sheet iron over the seat and the chest filled with blocking so that the cover will close down on it firmly and make a steam-tight joint, proceed on one side without disturbing anything except the valve rod.

59. Put the lever in a notch forward where one would be safe in starting a train. Then raise the link on the disabled side to the same level as the good one and block between top of link block and link. Have another block ready of sufficient length to raise the link enough, should it be necessary to back up the engine.

60. Reversing the engine, unless the

disabled side has been changed by raising or lowering to correspond with the good side.

61. By a lame exhaust, or with a bad slip, one of the exhausts disappearing entirely, and by watching the crosshead to note when the exhaust takes place.

62. Having located the eccentric, if it is a go-ahead, move the engine so that crosshead will come very near to the end of its travel ahead. Then move the eccentric around pointing in the opposite direction to the back-up, leaning either toward or from the pin—which would depend entirely on the style of valve and whether direct or indirect motion. As soon as steam appears at front cylinder cock, tighten set screws.

For back-up eccentric, lever and crosshead will have to be placed in the opposite direction. The best way is to mark eccentrics before starting, by placing the lever in forward notch and having crosshead at front end of travel. Then make a mark on crosshead and guide, doing the same with eccentrics and straps. If from any cause an eccentric slips and engine is placed so that mark on crosshead corresponds with that on guide, the marks on three of the eccentrics will correspond with those on straps, while the fourth or slipped eccentric's mark will be some distance away from mark on its strap. By this method an eccentric can be set as true as any machinist can set it, and there is no guesswork.

63. Take down the other strap and rod, cover ports and leave main rod intact.

64. Unless the link interferes, all that is necessary is to remove broken part of the arm, cover ports by placing valve in central position and leaving main rod up; otherwise the eccentric straps and rods would have to come down. With a broken link block pin, there is more or less danger of interference between link and rocker arm. Take down eccentric straps and rods only, and cover port.

GENERAL

Questions Answered

MENTAL QUALITIES OF FIREMEN.

(77) D. G., Dayton, Ohio, asks:

1. What is a fireman's most necessary mental quality? A.—We would say that "willingness" is a good quality to display, because it implies energy, and preparedness to learn. It makes a man do more than just what the law calls for.

2. What is the second mental qualification of a satisfactory fireman? A.—"Coolness" is also a most desirable quality, as it implies good temper and ability to do the right thing in the right way and at the right time.

PARTLY CLOSED THROTTLE.

3. Name four advantages exclusive of economy of steam which results from using high pressure steam with short cut-off, as compared with throttled steam and late cut-off. A.—In answering this question we quote from "Locomotive Running and Management," by Angus Sinclair, twenty-first edition, page 303. The author says: "Locomotives that are run with the throttle partly closed, when, by notching, the links back, it could be used open, are throwing away part of the fuel saving advantages that high pressure offers." He further says "—many locomotives are constructed with valve motion so imperfectly designed that the engines will not run freely when they are linked close up." One of the principal troubles with steam distribution for high speeds is not so much the getting steam into the cylinders, but

fer you to the November, 1904, issue of RAILWAY AND LOCOMOTIVE ENGINEERING, page 500, for an answer to this question.

HORSE POWER OF FALLING WATER.

(79) Inquirer, Pittsburgh, Pa., writes:

There is a small waterfall, about 25 ft. high, on a creek near my home, and I have often wondered how much power could be got from it to generate electricity. Could you give me a rule for figuring the probable power? A.—The weight of water falling and the height multiplied together will give the foot pounds. The quotient divided by 33,000 will give the horse power per minute. Suppose the stream sends down over 25 ft. of fall 600 gallons per minute. We have $600 \times 8.34 = 5,024$ pounds $\times 25$ ft. = 125,000 foot pounds, or close to 4 h.p.

In this connection we may say that there is a tendency among farmers and others, who have flowing brooks, to over-



A WESTERN STOCK TRAIN—30 CARS SHOWN AND MORE FOLLOWING.

Photo by F. Jukes, Rawlins, Wyo.

it is getting it out quickly. The kind of work the engine is doing and the efficiency of the valve gear have to be taken into account.

STAYING CROWN SHEETS.

(78) M. S., Biwabik, Minn., asks:

1. How many methods of staying crown sheets in locomotive boilers are there? A.—There is the direct radially placed stay, which ties crown sheet to roof sheet. There is the crown bar method, where the ends of the crown bars are supported on the edges of the fire box side sheets, and there is the crown bar method, where the ends of the bar are not so supported. In either of the crown bar methods sling stays from the roof sheet are used to support the bars.

2. How can one tell direct from indirect valve motion? A.—We would re-

estimate the power to be obtained from the water.

ANGULAR ADVANCE OF ECCENTRICS.

(80) J. W. S., Davenport, Ia., asks if there is a rule or formula for finding the angular advance of eccentrics when the lap and lead are known? A.—One way of finding it is as follows: You know the lap and lead. Suppose that both added together equal one inch. Now, it is also necessary for you to know if the arms of the rocker in either direct or indirect motion are the same length. In this case suppose they are. Place the driving wheels where there is a good plank floor below the axle; get the right crank pin on forward quarter and drop a string over the axle; this string to have a pointed plumb bob on each end. By moving the string along the axle you will get points enough on

the floor to lay off a representation of the axle on the planks. Suppose you are setting the "go ahead" eccentric on the right side and the motion is indirect. This eccentric will follow the crank pin. Place it temporarily with the bulge standing upwards; you can get this exactly by using the string with the plumb bobs over the eccentric. Now, on the floor, you have the diagram of the axle and the eccentric with no angular advance. To find the angular advance equivalent to one inch lineal advance, move the eccentric toward the crank pin such a distance that the point of the plumb bob nearest the crank pin shall have moved one inch from the line marking the eccentric in its vertical position, tighten up the set screw and you have the eccentric with the requisite angular advance. We propose publishing an illustrated article soon dealing with this subject.

FINDING WEIGHT OF STEAM.

(81) R. H. E., Santa Rosa, asks:

1. Rule for getting weight of steam under different pressures? A.—Any good table of the properties of saturated steam will give you this. Such a table is given in mechanical engineers' pocket-books or similar works, such as "Twentieth Century Locomotives."

TO FIND MEAN EFFECTIVE PRESSURE.

2. Rule for getting mean effective pressure of steam at different points of cut-off in cylinder. A.—Multiply the boiler pressure by the decimal fraction corresponding to the cut-off. For $\frac{1}{4}$ cut-off, multiply by .597; for $\frac{1}{3}$, by .670; for $\frac{1}{2}$, by .743; for $\frac{2}{3}$, by .847; for $\frac{3}{4}$, by .917; for $\frac{4}{5}$, by .937; for $\frac{5}{6}$, by .966, and for $\frac{7}{8}$, by .992.

TO FIND POWER OF COMPOUNDS.

3. Rule for getting the power of a compound engine of cut-off? A.—The formula for calculating the tractive power of a compound engine is similar to that of a simple engine except that the mean effective pressure at the given cut-off must be used. This can only be approximated, but to be reliable it should be obtained from an indicator diagram.

SIZE OF SMOKE STACK AND CYLINDER.

(82) J. W. S., Live Oak, Fla., asks:

1. What is the proper size for a straight stack for a locomotive with reference to the size of the cylinder? A.—There is no hard and fast rule on this matter and there is no settled ratio existing between the diameters of the stack and the cylinders. Some roads make the area of a cross section of the stack about 75 or 80 per cent. of the area of a cross section of cylinder; the question is largely a matter of quality of fuel and local conditions.

2. How high should the exhaust nozzle be, and what size should the nozzle tip be according to size of cylinder?

A.—There is no hard and fast rule in this matter. The top of the exhaust nozzle is often put at or near the horizontal center line of the boiler and the nozzle tip should be as large as can be used. The quality of fuel, the smoke box arrangements and the kind of work the engine is doing have to be taken into account in getting the size of tip best suited to the particular engine.

TO PAINT SMOKE BOXES.

(83) Fireman, Indianapolis, Ind., writes:

I wish to get a recipe for making a boiler head and smoke stack dope that will make a good shine without too much work. Will you answer this question in the columns where you tell things to readers of LOCOMOTIVE ENGINEERING? A.—We know of nothing better than Dixon's Silica Graphite Paint, which is ready for use. Apply to Joseph Dixon Crucible Co., Jersey City, N. J., and say that we advised you to do so.

STRENGTH OF HOLLOW COLUMNS.

(84) W. I. P., New York, asks:

Is a hollow pillar stronger than a solid one of the same size? A.—No, it is not, the difference in strength may be explained this way: If you had just 100 lbs. of material out of which to make a pillar you could dispose of the metal better and make a column of greater diameter if you made it hollow and the enlarged hollow 100-lb. pillar would be stronger than the small solid 100-lb. pillar. For equal sizes the solid column is the stronger of the two.

AIR BRAKE CORRESPONDENCE

BRAKE CYLINDER PRESSURES.

(85) R. L. C., San Francisco, Cal., asks:

If the pressure in the auxiliary reservoir and brake cylinder, in both Westinghouse and New York brake, have equalized after an emergency application, in which make of brake will the pressure on the piston head be greater? A.—The Westinghouse would have about 60 lbs. and the New York about 53 lbs.

EMERGENCY APPLICATION PRESSURES.

(84) R. L. C., San Francisco, Cal., writes:

In an emergency application of the Westinghouse brake, train pipe pressure is allowed to flash to the brake cylinder. In an emergency application of the New York brake, train pipe pressure is allowed to flash to the atmosphere. Which make of triple valve takes more air from the train pipe in one emergency application? A.—If the standard size of auxiliary reservoir be used for both triples, and be charged to 70 lbs., then an emergency application be made, the Westinghouse triple would give about 60 lbs. in the brake cylinder, auxiliary reservoir and train pipe, while

the New York triple would give about 53 lbs. in brake cylinder, auxiliary reservoir and train pipe; hence, more air would have been taken from the New York train pipe.

BEST USE OF TRAIN LINE PRESSURE.

(85) L. R. C., San Francisco, Cal., writes:

The air flashes from the train pipe to the atmosphere, with the New York triple, to set the brake in emergency, and gives a quicker equalization of auxiliary and brake cylinder pressures than the Westinghouse does, which flashes quickly train line pressure to brake cylinder and a slower equalization of auxiliary reservoir and brake cylinder pressure takes place. Which brake uses this train line pressure to best advantage, the New York to get the brake on quickly at a lower pressure, or the Westinghouse brake to get a high pressure in the brake cylinder and equalizing more slowly? A.—In actual tests made to determine this point, the pressure on the piston head with the Westinghouse brake was greater and the length of stop was shorter; hence, the train line pressure vented to the brake cylinder must have been used to better advantage than if quickly vented to the atmosphere to get the brake on at a lower pressure as quickly as possible.

PARTIAL SERVICE, THEN EMERGENCY.

(86) L. W. K., Truro, N. S., writes:

After making a 10 lb. reduction in service application of the brake, then an emergency application is required, what pressure can be obtained in brake cylinder with standard piston travel? Train line pressure is 70 lbs. Do the emergency valves operate in this case? A.—To obtain the highest possible cylinder pressure, an emergency application should be made with full train line and auxiliary reservoir pressures, and empty brake cylinder. After the train pipe and auxiliary reservoir pressures have been somewhat reduced, and the brake cylinder pressures have been partly built up, due to a light service application, it is still possible to get a part of the quick action application; that is, it is still possible to get a part of the train line pressure into the brake cylinder by making the quick reduction of train line pressure, but the brake cylinder pressure will not be as high as if an emergency application were made at the start, with full train line and auxiliary reservoir pressure and empty brake cylinder. When a service reduction of 10 lbs. has been made, perhaps 2 to 5 lbs. higher brake cylinder pressure may be obtained than if a full service application were made. In getting train line pressure into the brake cylinder in quick action application, the emergency valves must operate, no matter whether the application be full or partial.

Air Brake Department.

CONDUCTED BY F. M. NELLIS.

New Air Brake Book.

The Proceedings of the Eleventh Annual Convention of the Air Brake Association, held in Buffalo, N. Y., May 10, 11 and 12, comes to us fresh from the press. This book teems with useful information and interesting reading. One of the most instructive features is the paper on brake shoe friction, and is undoubtedly the best information on this subject extant. Another valuable feature is the paper on "Electric Car and Train Brakes," being the first one of this kind handled by the Air Brake Association. Further valuable information in this book is the Master Car Builders' standard foundation brake gear for passenger cars of all weights, this being a very full and complete description of the findings of the committee appointed by the Master Car Builders' Association to investigate this subject. Those wishing information on this subject will find all about it in these proceedings. Besides these features there are others, among which are "Higher Train Pipe Pressure" and "Better Method of Basing Braking Power for Cars of All Weights." The subject of stenciling cylinders, auxiliary reservoirs, triple valves, high speed reducing valves, etc., is neatly handled and well illustrated in this book. The subject of brake beams comes in for its share of discussion and should be read by all those who wish to be up to date in the air brake art. The subject of back-up-hose and its use on trains is also well handled. Much information is contained in the paper and the discussion which followed. Throughout, the whole discussion is exceptionally interesting and instructive. The book contains 284 pages and is furnished in two bindings, handsome paper cover for 75 cents and leather bound for \$1.00.

CORRESPONDENCE.

Triple Valve Testing Machine.

The accompanying photograph shows the installation of a valve testing machine, at the Renova shops of the Pennsylvania R. R. Co.

As will be seen, this machine is quite compact in its arrangement. It is also equipped to test high speed reducing valves and other parts of the air brake, besides the triple valves.

The controlling valve and other parts of the machine are placed conveniently above the table, where they are acces-

sible for inspection and repairs, instead of underneath, as is the general practice.

Renova, Pa.

R. N. MARTIN.

A Remarkable Runaway.

Here is an odd case of an "air brake failure" with a light engine and tender.

An engineer having only a light engine and tender, tipped over the summit of a two per cent. grade and took the side track, four miles below, to permit an

replaced the liners, tightened up the bolt, and crawled from under the engine. As the passenger train had just gone up on the main track, he called to the fireman to open the switch below; the engineer kicked the blocks from under the wheels, and the fireman ran down to the switch and opened it.

The engine, after the blocks had been kicked from under the driving wheels, began to move forward. The engineer realized that his brakes had leaked off through the leather packing in the driver

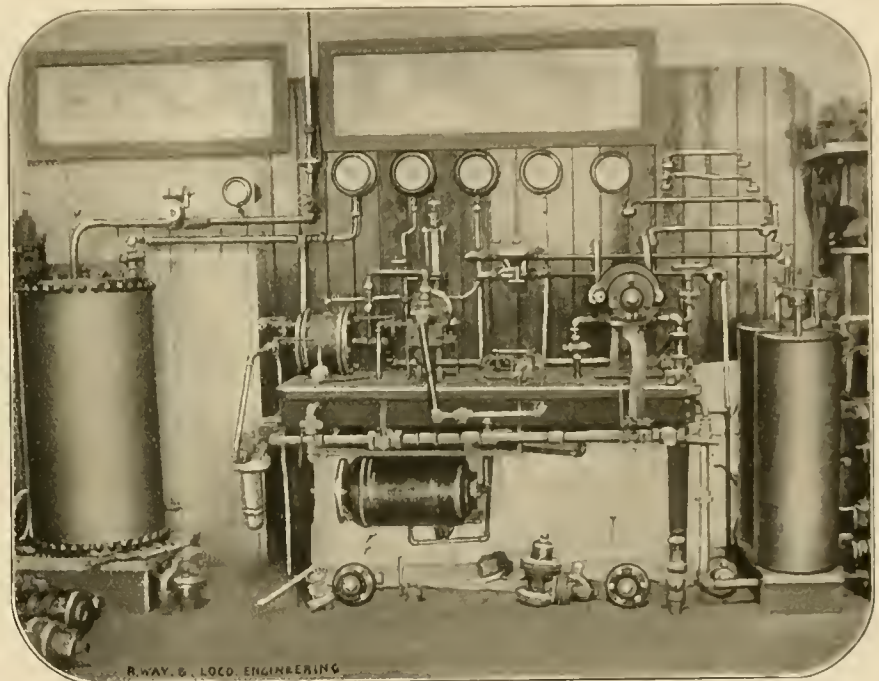

TRIPLE VALVE TESTING PLANT AT P. R. R. SHOPS, RENOVA, PA.

up-bound passenger train to pass on the main track.

In going on to the side track, the engineer made his stop with the air brake, left the air set, and pulled back his reverse lever to oil around. He was surprised to find that the lever would not pass back of the center notch. He left the air set, blocked the driving wheels, and, taking his hammer and monkey wrench, crawled under the engine to find the trouble in the valve gear that prevented the lever from being moved back of the center notch.

The first thing he found was a loose eccentric strap bolt, permitting two of the eccentric strap liners to slip out of their places, and these projected and rubbed against the other eccentric strap.

Assuming this to be the trouble, he

brake and tender brake cylinders. He leaped on the engine, threw the brake valve handle to full release and pulled back the reverse lever. To his consternation the lever would not pull any further back than the center notch. The replacement of the eccentric liners had not removed the trouble.

He immediately threw the brake valve handle into emergency position, but as the auxiliary reservoirs on the engine and tender had not yet recharged, the brake would not hold with sufficient force to keep the engine from going forward down the side track. He tried to reverse the engine but the lever obstinately refused to pass back of the center notch. He released his brake to give it a better hold (as he thought), and again threw

it into emergency position, but it failed to hold.

By this time the engine was moving down through the side track and passed over the switch too fast for the fireman to get on, and the runaway was on. Realizing that he could not reverse his engine, and becoming "rattled" because his uncharged brake would not hold, the engineer began to whistle, and continued to whistle until the foot of the grade, eight miles away, was reached.

During the runaway trip, the engineer applied and released his brakes more than a dozen times. It doubtless dawned on him that he had not given the reservoir time enough to charge, but he was so "rattled" that he applied and released the brake indiscriminately.

At the foot of the grade he made a fine stop, having left his handle in full release, where he forgot it. A yard engineer stepped up on the engine, applied the brake and it held so tightly that steam would not budge the engine. This is a case of "rattles" and runaway with a light engine. With the help of the yard engineer, the real trouble of the reverse lever not coming back of the center notch was found to be a loose link block pin striking on the link saddle. Moral: Subscribe for RAILWAY AND LOCOMOTIVE ENGINEERING, and keep posted upon air brakes and engine breakdowns.

AMOS JUDD.

Boston, Mass.

The No. 5 New York Duplex Air Pump.

The monster locomotive and the 100-car train have made it necessary to bring

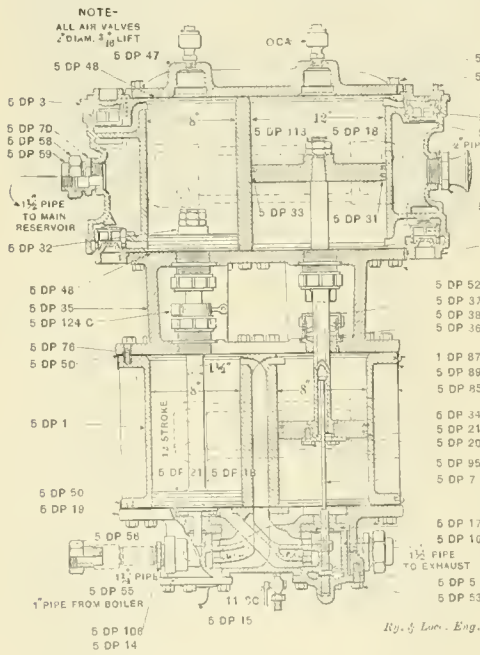

FIG. 1. NEW YORK DUPLEX AIR PUMP, No. 5.

out a large new air compressor of sufficient capacity to supply the quantity of air required to operate the brakes properly and also to provide a sufficient sup-

ply of air for the needs of the compressed air attachments with which the locomotive may be equipped, such as the bell ringer, the sand blower, the ash pan dumping devices, the automatic stoker, etc.

Many air brake men have been opposed

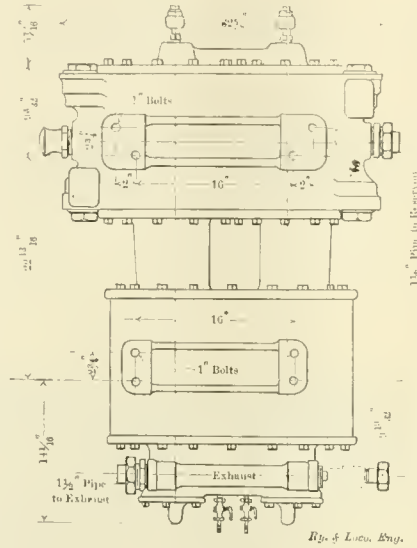

FIG. 3. NEW YORK DUPLEX AIR PUMP, No. 5.

to the introduction of the large air pump for the reason that a large pump seemed to them to invite still greater neglect of train pipe leakage than is now experienced.

This stand was probably well taken when trains consisted of not more than 50 or 60 cars, all eight-inch equipments; for then the present air pump had ample capacity to supply the train with the required quantity of air, provided, of course, no excessive leakage was allowed to obtain in the brake mechanism. But since the locomotive is gradually growing larger in size, and so with the train in proportion, it is easily seen that a large air pump applied to this class of locomotives may hold the same relation to it, and the train it is capable of hauling, that the smaller pumps formerly did to the locomotive to which they were applied and the 50 or 60 car train which they could haul.

Realizing that the locomotives and trains are getting larger and that locomotives will be equipped with numerous compressed air attachments, the New York Air Brake Company are now making a pump

large enough to supply air in ample quantity for the longest freight train which it is possible for a modern locomotive to haul, and also, in addi-

tion, for the compressed air attachments with which this locomotive may be equipped.

The pump is known as the No. 5 Duplex air pump, and it is illustrated by the figures which accompany this description. Very little need be said in the way of description of the pump, since the illustrations give nearly all the information that is required.

It might be said, however, that the principle of operation of this pump is just the same as the No. 2 duplex which has already been described in RAILWAY AND LOCOMOTIVE ENGINEERING.

The points of improvement in the large pump over the older styles, aside from its size, will be found in the matter of design, special attention being given to the facility in removing air valves and in getting at the different parts of the pump to make repairs. An extra pair of air inlet valves for the high pressure cylinder are provided in order to supply ample opening for the entrance of free air.

Referring to the illustrations, Fig. 1 is a vertical section through the pump showing the arrangement of cylinders, the design of the air and the steam pistons, the steam chests, the valves, the bushings, the caps, etc. From this figure it will be seen that all air valves are alike, are 2 ins. in diameter, have a lift of $\frac{3}{16}$ of an inch, and are easily accessible. Each valve is in a cage by itself.

The steam chest caps, 5 D.P. 15, are attached to the pump by means of tap bolts instead of being screwed in, as in the No. 1 and No. 2 pump. This makes their removal easy when repairs to the slide valve or tappet rods are

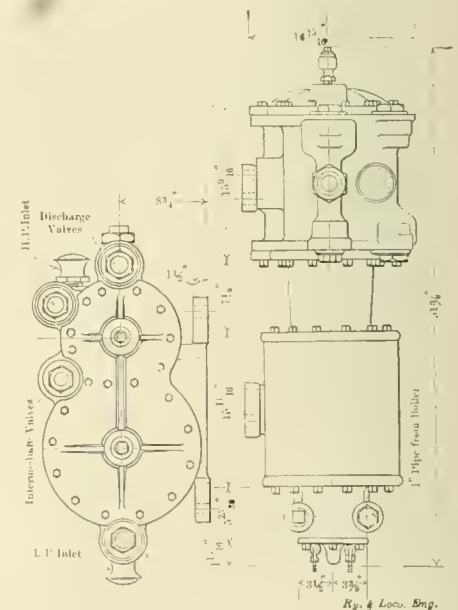

FIG. 2. NEW YORK DUPLEX AIR PUMP, No. 5.

necessary. The sizes of the various pipe connections, etc., are also shown in Fig. 1.

Fig. 2 is a plan view of the pump

looking down upon the top of the air cylinders. In this view the position of both the low pressure and the high pressure inlet valves is indicated, and it may also be seen that there are 4 air valves for each end of the pump, and that the high pressure air cylinder has an independent air inlet. At the lower end of the air cylinders there are 4 air valves corresponding to the upper 4 valves.

Fig. 3 is a view of the rear elevation

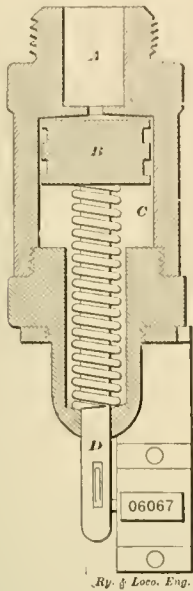

AIR PUMP STROKE COUNTER.

of the pump and shows the dimensions over all, also the brackets for bolting the pump to the locomotive, the number of bolts required, and their size. This view shows two drip cocks in the steam head—something a little different from the usual practice. One is tapped into the exhaust passage, the other into the live steam passage; this is done so that it will be unnecessary to apply drip cocks in the exhaust pipe.

Fig. 4 is a side elevation giving the dimension which shows that the pump may be placed on either side of the boiler, either right or left, without change in method of piping the steam head.

The pump is, as may readily be seen from the dimensions of the air cylinders, of very large capacity, its efficiency is correspondingly high, and it will furnish air in ample quantity for the modern long trains, even when they are made up largely of cars equipped with 10 in. brake cylinders.

J. P. KELLY.

Watertown, N. Y.

Stroke Counter for Air Pump.

The illustrations, Fig. 1 and Fig. 2, show a neat little device for mounting and recording the strokes of an air pump, for testing and other purposes requiring a knowledge of the number of strokes made in a given time.

Fig. 1 is an exterior view of the de-

vice, which is made up of a body, screwing into the pump head of the air cylinder, after the plug has been removed. The lower portion attached to the body is the ordinary revolution, or stroke, counter, used on bicycles for registering the revolution of the wheel, and also on engines and other machines.

Fig. 2 is a sectional view of this device. Air pressure enters at A, passes to the top of the piston, B, and forces the piston downward against the resistance of the spring, C. The piston rod, D, is slotted in its lower end to receive the lever, E, of the recorder. At each downward motion of the piston, B, and its rod, D, the lever, E, is forced down, notching up a revolution. When piston, B, and the rod ascend, due to the escape of air from the top of piston, B, and the spring, C, the piston, B, upward, lever, E, is raised to its uppermost position, making the recorder ready for another notch and count. Thus the down stroke of the pump forces the piston, B, downward, and the up stroke, when air is drawn into the air piston, causes the piston, B, to ascend. In this way the counter is made to notch up one figure for each double stroke.

The illustration should show packing rings in the piston, B, although they are omitted in the cut.

FRANK F. COGGIN.

Portland, Me.

under on each of the two trucks? This arrangement, of course, would mean a flexible connection, such as a rubber hose, between the main train pipe and triple valve; but if such a connection were placed near to the center bearing of the truck and car, where the movement is very slight when the truck curves, little strain and wear would be had on this flexible coupling.

With the proposed arrangement of a single cylinder for each truck, a drawing is presented herewith which will

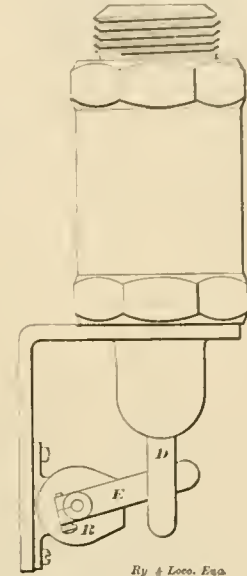

AIR PUMP STROKE COUNTER.

A Brake Cylinder on Each Truck.

The question of larger cylinders for heavy six wheel truck cars is becoming more serious each year, especially as the weights of the modern car is increasing each year. A few years ago it was an unusual thing to find a six wheel truck under cars other than a Pullman car. To-day, nearly all passenger equipment cars built are of such heavy weight as require and are best adapted to six wheel trucks. So great has the weight of modern cars become that even the 16 in. cylinder is too small to brake to

doubtless be interesting to readers. It will be seen that a very substantial brake gear can be installed by this plan. The total leverage can be made as low as 7 to 1, with a 12 in. or 14 in. brake cylinder. Why would not such a brake be preferable to one large cylinder in the middle of the car?

D. R. JONES.

Kingston, N. Y.

Slack Adjuster's Good Performance.

Mr. Davidson's article on the slack adjuster in November issue gives some very valuable information.

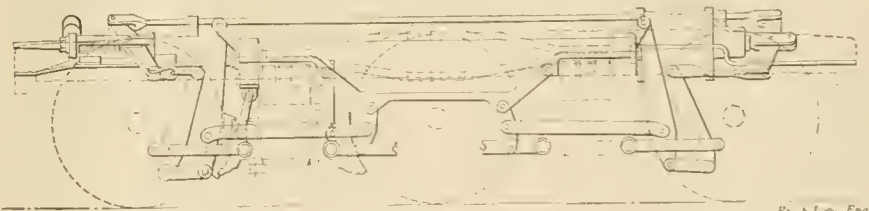

BRAKE CYLINDER ON EACH TRUCK.

90 per cent. of the weight of the car, and give sufficient shoe clearance. Still greater is the undersize of the 16 in. cylinder, if the unbraked weight plan is employed in the heavy modern car.

Instead of increasing to the 18 in. cylinder for the heavy modern six wheel cars, above 120,000 lbs. in weight, would it not be better to install a smaller cyl-

A great deal has been said about the light applications made to steady trains around curves, etc., and there has been considerable room for doubt that the adjuster would operate a sufficient number of times to compensate for these light reductions.

J. B. HOWE.

Covington, Ky.

Tank Cars and Safety Valves.

The tank car committee of the Master Car Builders' Association made a test not long ago on a Union Tank Line car for the purpose of ascertaining whether or not all tank cars of 6,000 gallons capacity or less should be equipped with one or two 5 in. safety valves.

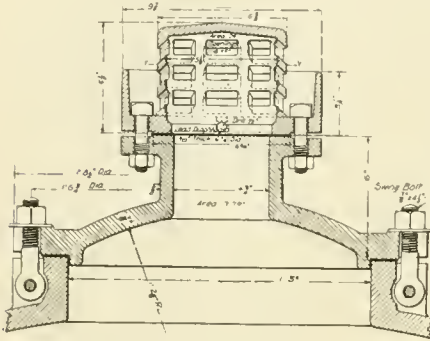

SAFETY VALVE FOR TANK CARS.

The car experimented on had a steel tank with a capacity of 6,491 gallons, measured to the base of the dome, but at the test it actually contained 6,509 gallons of stove gasoline. The inside diameter of the tank was 76½ ins. and the length 26 feet. It was composed of five barrel sheets 3/16 in. thick, with bottom sheet made of ¼ in. plate; the dome was 3/16 in. plate, with a diameter of 36 ins. and ¼ in. dome cap. The longitudinal seams of the bottom sheet were double riveted, all others were single riveted. The end heads of the tank were dished 7½ ins.

This tank was placed in a field and stood on three brick piers 12 ins. thick and 16 ft. from center to center. The center pier was 24x24 ins. in section and was placed directly under the ordinary tank nozzle for the purpose of protecting it. A pipe 1 in. in diameter was run from the tank to a point 700 ft. away for the purpose of recording pressures.

The actual test was made by lighting a series of burners placed below the tank in such a way as to produce a uniform blaze. The contained liquid was evaporated to dryness. At the start the tank was full and the 66½ per cent. naphtha extended about 4 ins. up into the dome, containing 6,509 gallons at 76° F., which equals, when corrected, about 60° F. and 6,437 gallons. The temperature at the top was found to be 89°, at the center 71° and at the bottom 68°.

The report continues: "The conditions, so far as the safety valve was concerned, were just such as would be met with in service when tank cars carrying naphtha become suddenly surrounded by fire. The safety valve operated perfectly, opening promptly at the desired pressure at which it was set, namely, eight pounds, and the pressure never exceeded 13½ lbs.

It was especially noticeable that the safety valve, which was in accordance

with the design recommended to the M. C. B. Association, not only relieved the pressure but also discharged the flame upward in a compact column, the only flame coming down from the safety valve being that through the small vents which are placed around the seat in order to entrain and carry away water accumulating from rain."

The valve, as will be seen by the engraving, is really a cap having a 4¾ in. aperture covered by a diaphragm of lead. The area of this aperture is 17.7 sq. ins. and the lead was ruptured at a pressure of 8 lbs., allowing the escape of the liquid contained in the tank. The conclusion of the committee is that one such valve is all that is required on tank cars of 6,500 gallons capacity and under.

Handy Wheel Hoist.

Our illustration shows a very simple but effective wheel hoist in use in the Erie Railroad shops for lifting car wheels to and from the boring mill bed.

The device, as seen from the half

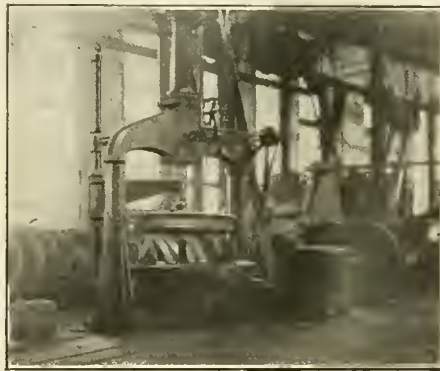

HANDY WHEEL HOIST.

tone, is nothing more than a 3 in. rod secured to a piston which operates in a cylinder whose diameter is 10 by 24 ins.

A guide post secured to the press guides this rod in its upward or downward movement and the projecting arm on the rod permits of a horizontal movement. The arm is provided with three hooks, which are inserted into the core holes of the wheel.

Air is admitted and exhausted from the cylinder through a ¾ in. gas pipe, and an exhaust opening is provided in the cylinder near its upper end to guard against a too great or sudden admission of air. Not only does it save time and labor to the operator, but it has reduced the demand for profanity as well.

The Southern Railway Company are making several important improvements on their track which will increase the popularity of travel on that great system. Rock ballast has been put under a great mileage and the work on that method of securing a solid track is pro-

gressing vigorously. Double track has been laid between Washington and Orange, Va., 85 miles, where the heaviest traffic is carried and the intention is to extend the double track as rapidly as the finances of the company will permit.

Perfect Accuracy.

An Irishman fresh from the famous Emerald Isle, who had little acquaintance with railroads, either in his own country or in the United States was shown by an enthusiastic friend the portal of a tunnel on one of our far western lines. Pat was delighted by the mountain scenery which was spread out like a panorama before him, and he enjoyed it hugely.

By and by an express train came along at a high rate of speed on the carefully block signaled, single-track road. Pat saw the engine and the cars as they raced along and was struck dumb with astonishment and delight. On they came, and as the mouth of the tunnel was neared the engine emitted a loud, warning shriek for the benefit of some track laborers, who got out of the way in that exasperatingly deliberate way which section gangs exhibit on the approach of a "rusher." The train dashed into the tunnel and was gone, and the track men came back to work even more slowly than they had quitted it.

After the rumble of the train had died away in the bowels of the earth, and the section hands were at it again in the regulation fashion, Pat was heard to remark in an awe-struck whisper, "It's great—but wouldn't it have been h—if she hadn't struck the hole?"

New Sanding Device.

A sander has recently been invented by Mr. J. H. Watters, assistant master mechanic of the Georgia Railroad, Augusta, Ga.

It is specially designed to work sand

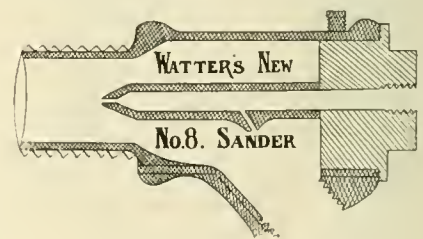

WATTERS' SAND VALVE

containing loam or which becomes caked in the sand box. One of the air jets discharges directly into the sand, agitating it, and the other jet creating a partial vacuum in the discharge pipe draws the sand out. They do not interfere with the old hand lever valves, and can be applied to any kind of a sand

box by simply screwing them into side wall above the floor. They will work either forward or backward.

The sander is composed of two parts and these can be taken apart without disconnecting the pipes. The parts cannot be put together wrongly. The sander will work with water as well as with air. A patent has been applied for on this device. Any information concerning it will be cheerfully given by the inventor.

Balanced Baldwin Compound for the N. Y., N. H. & H.

The New York, New Haven & Hartford Railroad have been getting some balanced ten-wheel compounds from the Baldwin Locomotive Works. One of these engines is here illustrated.

The cylinders are 15x25x26 ins., and the driving wheels are 72 ins. in diameter. Both high and low pressure pistons drive on the leading axle, while the eccentrics are placed on the second

318 in number and are 15 ft. 1 in. long. They contain 2,497.5 sq. ft. of heating surface and with the 168.5 sq. ft. of the fire box gives a total heat absorbing surface of 2,666 sq. ft. The crown sheet staying is radial and the crown sheet is level. The grate area is 34.69 sq. ft.

The smoke box is of the extension type but most of the space is between the smoke stack and the round head or front flue sheet. The cylinders are placed further forward than is usual in order to get room for the connecting rods which, as shown in our illustration, are necessarily short. The weight of the engine is 160,600 lbs., the drivers carrying 123,100 lbs., and the truck 37,500 lbs. The engine and tender together weight about 270,000 lbs. The tank has a water capacity of 5,000 U. S. gallons. Some of the principal dimensions are as follows:

Boiler—Thickness of sheets, $\frac{7}{16}$, $\frac{1}{4}$ and $\frac{5}{16}$ ins.;
working pressure 200 lbs.
Firebox—Length, 120 $\frac{3}{8}$ ins.; width, 41 $\frac{1}{2}$ ins.; depth,

relief except that which a lifting of the valve from its seat might afford, bursted the forward head, because it required less pressure to burst the head than to force the valve from its seat.

T. P. WHELAN.

Permanent Railway Museum.

When the present exhibit of the Baltimore and Ohio Railroad at St. Louis was being collected, it occurred to Major J. G. Pangborn, to whom is due the credit for its completeness and attractive installation, that it should form the nucleus of a great permanent railroad museum. During the summer he has been actively engaged in interesting railroad companies in the project and is meeting with a very fair success.

The incentive to making the showing of the evolution and development of the world's railway at Chicago in 1893, was, largely, in recognition of the fact that if historical originals were to be

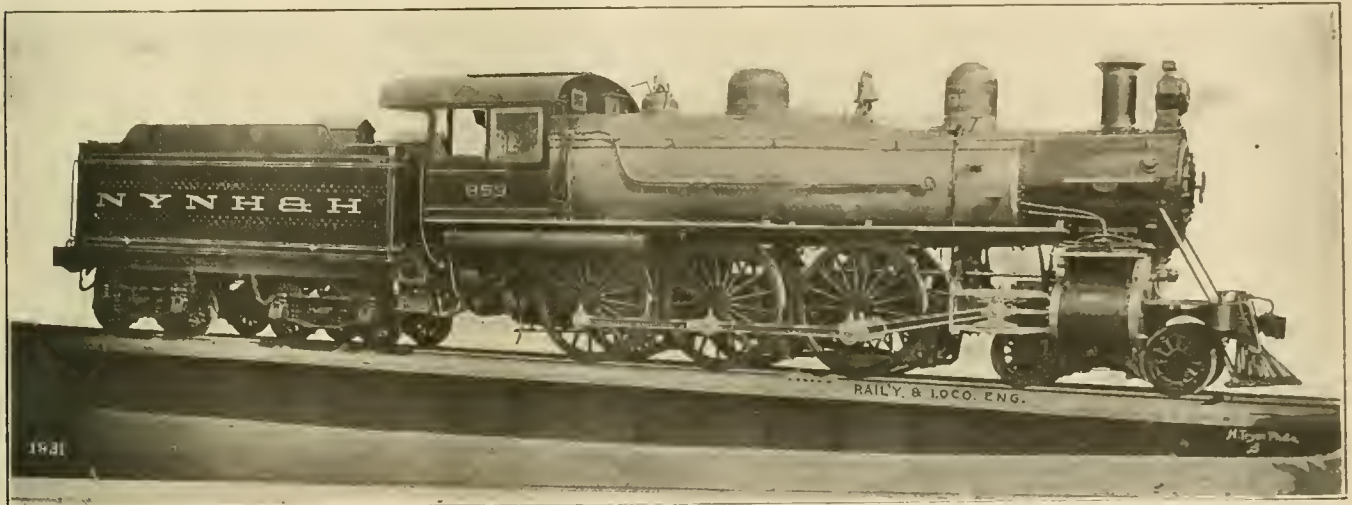

F. N. Hibblitts, Mech. Supt.

BALANCED COMPOUND FOR THE N. Y., N. H. & H.

Baldwin Loco. Works, Builders.

driving axle. The valve being of the balanced piston type and placed immediately above the frame, permits the valve stem and the rocker to be behind the leading driver. The driving wheels are evenly spaced and all are flanged.

The balancing is arranged in the manner usually employed by the builder where a crank axle is employed. When the crank pin of the right main driver is on the bottom quarter, as shown in the engraving, the right high pressure crank, in the axle, is on the top quarter; therefore, when the engine is running, both pistons move in opposite directions. The counterweight of the leading driver is not large and is placed close to the outside crank pin.

The boiler of this engine is of the wagon-top type with the taper course in front of the dome. The diameter at the smoke box end is 60 ins. The tubes are

front, 73 ins.; back, 62 ins.; water space, front, 4 ins.; sides, 3 ins.; back, 3 ins.

Wheel base—Driving, 13 ft. 6 ins.; total engine, 27 ft. 5 ins.; engine and tender, 56 ft. 8 ins.; engine truck journals, 5 $\frac{1}{4}$ x10 ins.; tender truck journals, 5x9 ins.

Neglecting the Stitch.

Mr. W. de Sanno, in the November number, says there is evidently a missing link in my article in the October issue, as he cannot see what connection the lameness of the 49 would have with the blowing out of a cylinder head. I hope the following will explain sufficiently.

When the 49 first commenced to limp it was caused by a partial slipping of a go-ahead eccentric. When we reached that point in the road where Dan widened on her the eccentric let go completely, leaving the valve in position to cover the forward admission port, and the piston coming forward compressing a full cylinder of steam with no possible

preserved, action to this end could not be longer deferred. Only at the South Kensington Museum in London had there been effort in such directions, being a general assembling of old-time relics of a mechanical nature. Fortunately the impulse was in time to save Hedley's "Puffing Billy" of 1813, Stephenson's "Rocket," Hackworth's "Sans Pareil" and Foster & Rastrick's "Angenoria" of 1829. The latter was constructed from the same drawings as the "Stourbridge Lion," which was shipped by sailing vessel to the United States and was the first locomotive seen in this country. The North Eastern Railway of England has the No. 1 of the Stockton & Darlington, and, in a Paris institution, is the original "Cugnot" of 1769, the first to move by head of steam on earth. Beyond these examples few, if any, are

accessible abroad as object lessons through which to trace beginnings, often of importance in later development.

It was regarded as fitting that the Baltimore and Ohio should assume the initiative looking to the eventual establishment of a world's institution wholly devoted to the railway and allied interests. It was the pioneer in American railway inception, and its own possessions are representative of the early days comprising an aggregation of inestimable worth.

The feasibility of combining material and means, and applying to all the ends indicated, is greatly strengthened through the tender by the city of Philadelphia of an existing structure most admirably adapted to meet the requirements. It offers a clear floor space approximating a hundred and twenty thousand square feet, with a general height of thirty feet. It is exceptionally well lighted from the sides and overhead, has track facilities and pow-

Congress at Washington in May next; a consummation that, through the opportunities presenting for personal inspection and explanation, would, unquestionably, greatly augment foreign concurrence in the general plans.

The Laurier Bridge.

The bridge here illustrated is on the line of the Chateaugay & Northern Railway. It crosses the Ottawa river at the north end of the island of Montreal. The bridge is called after Sir Wilfred Laurier, the Premier of Canada. It is built across two channels of the river, one from Bout de l'Île to Île Bourdon and the other from Île Bourdon to the mainland at Charlemagne. The Bout de l'Île section consists of 8 spans, each of 140 ft., and one span in the center 200 ft., with a 46 ft. span at either end. The Île Bourdon section is made up of 7 spans of 140 ft. each, with a 70 ft. span at each end.

er connections. The location is central, being on the sixteen-acre site skirting the Schuylkill the city has set apart for the grouping of institutions of a commercial and mechanical character. Ordinarily an edifice of the size demanded for the railway collection, its additions and accessories, would necessitate special construction and the expenditure of a large sum. This obviated, concerted action by leading railways and allied interests, to the extent of assuring maintenance pending the maturing of plans for endowment and permanent conduct, would make certain the preservation of the present accumulation intact, as, also the extensive and valuable accessions made and pledged. Meaning, in entirety, the complete occupation of the building offered, and installation perfected in time for the convening of the International Railway

the many types of pumps exhibited, but also air compressing and steam condensing apparatus, cooling towers, vacuum machines, water meters, etc., etc. The processes in which these machines are employed on the exposition grounds, such as timber preserving and refrigeration, are fully explained and diagrams and graphical charts are employed to illustrate the design and arrangement of apparatus. A striking view of the Grand Cascade is shown on the cover and the immense Worthington turbine pumps by which the water is supplied are described in the text. This publication is distributed gratis.

Locomotive Stoker Company.

A company called the Victor Stoker Company was formed last month in Cincinnati, with a capitalization of \$200,000, for the purpose of manufacturing automatic stokers for locomotives and ocean-going steamers.

The following stockholders are in the company: S. F. Dana, president of the Campbell's Creek Coal Company; William Christie Herron; M. E. Ingalls, president of the Big Four Railroad Company; L. A. Ault, Frank Wiborg, D. T. Williams, Harry M. Levy, Arthur Stem, D. A. Wallingford, Jr., J. H. Day, C. A. Kincaid, J. W. Kincaid, E. P. Harrison, Arthur Espy, L. F. Walters, J. C. McCarty, president of the McCarty Company, of New York City; George F. Dana, Dudley V. Sutphin, and George Hoadley.

The new company, says the *Cincinnati Enquirer*, takes over the entire business of the Day-Kincaid Stoker Company in this country and abroad, including the entire control of the patents covering 18 foreign countries.

The Day-Kincaid Stoker Company have placed these famous stokers on some eight or ten roads in this country, and to a limited extent in England, Sweden, Spain, India, South Africa and Japan, and are now completing an order for West Australia, and within the last thirty days have received applications for the exclusive rights in Italy and Great Britain.

There is in Cincinnati at the present time a small automatic stoker plant. The new company is the result of this small plant, which at the most only employs about 20 hands. The new concern will employ between 150 and 200 hands. Work on the buildings for the new concern will begin early next spring. The shops are to be modern in every detail and the exterior of the structures will be in keeping with the large factories now at Norwood.

It is not everyone can command success. But we'll do more, Sempronius, we'll deserve it.—*Addison*.



LAURIER BRIDGE ON THE CHATEAUGAY & NORTHERN, NEAR MONTREAL.

er connections. The location is central, being on the sixteen-acre site skirting the Schuylkill the city has set apart for the grouping of institutions of a commercial and mechanical character.

Ordinarily an edifice of the size demanded for the railway collection, its additions and accessories, would necessitate special construction and the expenditure of a large sum. This obviated, concerted action by leading railways and allied interests, to the extent of assuring maintenance pending the maturing of plans for endowment and permanent conduct, would make certain the preservation of the present accumulation intact, as, also the extensive and valuable accessions made and pledged. Meaning, in entirety, the complete occupation of the building offered, and installation perfected in time for the convening of the International Railway

The total length of the bridge is 2,532 ft. and the width is 40 ft., including a roadway 10 ft. wide on each side. The piers are built of concrete on pile foundations to within 2 ft. of the extreme low water mark and masonry from there up.

The Chateaugay & Northern is 36 miles long and runs from Montreal to Joliette, were it connects with the Great Northern Railway of Canada, which latter company operates the smaller road. We are indebted to Mr. F. A. Hibbard, chief engineer of the road, for the photograph and information concerning the bridge.

Forty types of pumping machinery at the St. Louis Exposition are described and illustrated in a handsome pamphlet, 8½x12 ins. in size, now being distributed by the International Steam Pump Co., of 114 Liberty street, New York City. Under this heading are included not only

The Richmond Compound.

BY H. C. ETINGER, AIR BRAKE INSTRUCTOR,
WABASH RAILWAY.

Before taking up the diseases of this type of locomotive, and remedies for same, the following description of its proposed functions may be given. Con-

work simple, as the open exhaust valve will permit the exhaust from the high pressure cylinder to escape direct to the atmosphere in which case there would be no accumulation of pressure in the receiver to force the intercepting valve and reducing sleeve into compound posi-

tion. However, if start is made with controlling valve in compound position (emergency exhaust valve closed), after one or two revolutions of the driving wheels the intercepting valve and re-

ducing sleeve will automatically change to compound position—this being due to the successive exhausts of the high pressure cylinder raising the receiver pressure to 30 per cent. of boiler pressure, in which event this pressure acting on the greater area at rear of intercepting

valve forces it ahead against the 40 per cent. boiler pressure, thus making direct communication between receiver and low pressure steam chest. As the intercepting valve is forced into compound position (open) a shoulder on its stem engages with the reducing sleeve carrying it forward, closing live steam admission port to low pressure side. It will thus be seen when working compound, the low pressure side gets all its steam from the high pressure exhaust through the receiver. Under the foregoing conditions, the pressure on the low pressure piston would be approximately 30 per cent. of boiler pressure, while on the high pressure piston there would be exerted the full boiler pressure minus 30 per cent. which, on this side, is back pressure. In case it is desired to convert the engine from compound to simple, it may be done at any time by simply changing the controlling valve from compound to simple position. When this change is made the admission of boiler pressure against the outer end of emergency exhaust valve piston, forces this valve open against the tension of its own spring, and the steam pressure in receiver acting on the inner end of the valve. The sudden exhaust of the receiver pressure from the small cavity at the rear of this intercepting valve in connection with boiler pressure acting on the small shoulder of the reducing sleeve, so unbalances the intercepting valve as to cause it to move back to its seat, thus

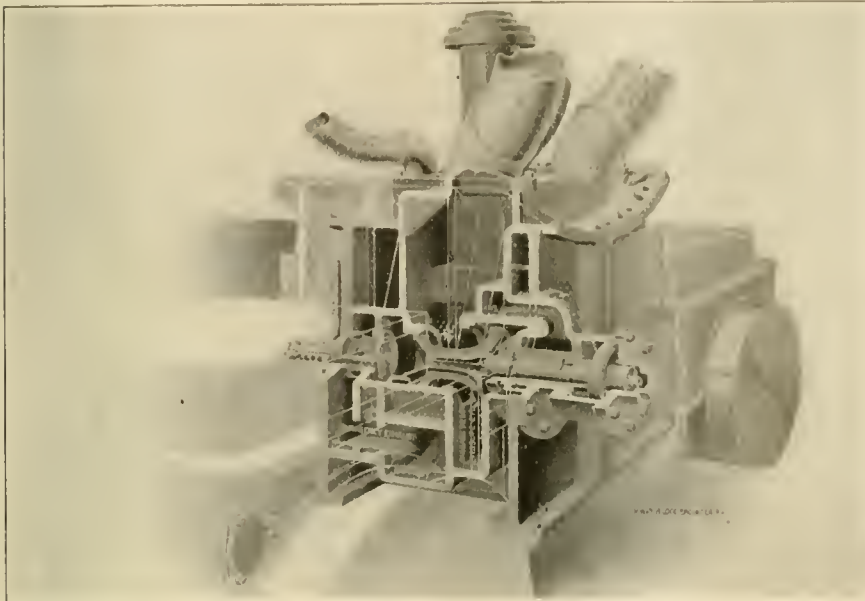

RICHMOND COMPOUND—INTERCEPTING VALVE IN COMPOUND POSITION.

nected to the nigger-head are the large and small steam pipes, the former leading to the high pressure steam chest, while the latter through the intercepting valve casing leads to the low pressure side.

When shutting off steam when working compound the reducing sleeve and intercepting valve which are in compound position, remain so until the throttle is again opened, at which time live steam engages with the small shoulder on reducing sleeve, forcing both sleeve and intercepting valve back into simple or starting position. The intercepting valve, which is now on its seat, closes communication between the main reservoir and low pressure steam chest, while the reducing sleeve, having opened the admission port, admits steam direct from boiler to the low pressure chest. When steam pressure in low pressure chest rises to 40 per cent. of boiler pressure, this pressure acting upon the greater area of the reducing valve at its back end, overcomes the resistance of the boiler pressure on the small shoulder, and forces the sleeve forward (toward the dash pot), and so closes the admission port. It will thus be seen no matter whether the controlling valve is in simple or compound position, the high pressure side is free from back pressure and the low pressure side gets its maximum pressure when start is made. If start is made with the controlling valve in simple position (emergency exhaust valve open), the engine will continue to

work simple, as the open exhaust valve will permit the exhaust from the high pressure cylinder to escape direct to the atmosphere in which case there would be no accumulation of pressure in the receiver to force the intercepting valve and reducing sleeve into compound posi-

tion. However, if start is made with controlling valve in compound position (emergency exhaust valve closed), after one or two revolutions of the driving wheels the intercepting valve and re-

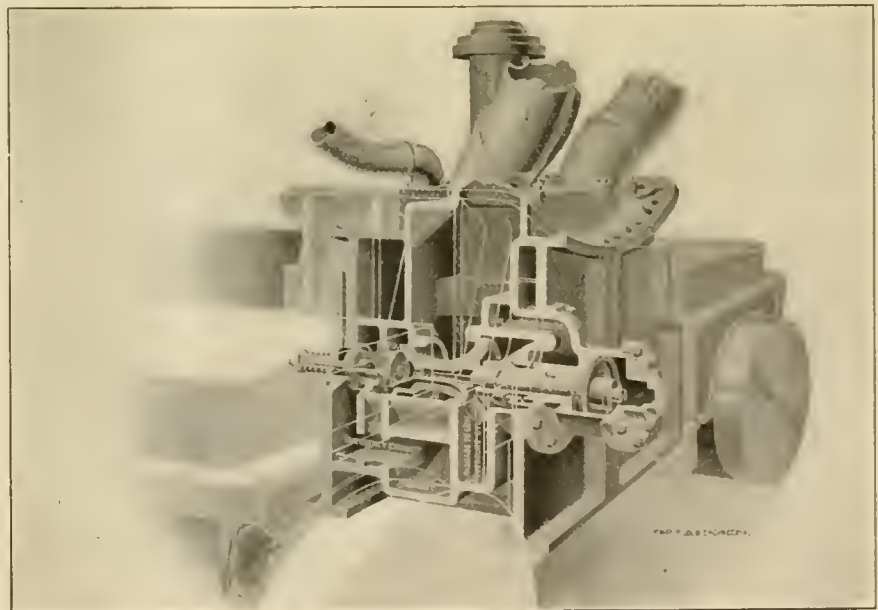

RICHMOND COMPOUND—INTERCEPTING VALVE IN SIMPLE POSITION

work simple, as the open exhaust valve will permit the exhaust from the high pressure cylinder to escape direct to the atmosphere in which case there would be no accumulation of pressure in the receiver to force the intercepting valve and reducing sleeve into compound posi-

tion. However, if start is made with controlling valve in compound position (emergency exhaust valve closed), after one or two revolutions of the driving wheels the intercepting valve and re-

ducing sleeve will automatically change to compound position—this being due to the successive exhausts of the high pressure cylinder raising the receiver pressure to 30 per cent. of boiler pressure, in which event this pressure acting on the greater area at rear of intercepting

valve forces it ahead against the 40 per cent. boiler pressure, thus making direct communication between receiver and low pressure steam chest, and at the same time opening the admission port admitting live steam to the low pressure side to the extent of 40 per cent. of the boiler pressure.

The increase of the pressure in low

pressure cylinder from 30 to 40 per cent. of boiler pressure, and at the same time relieving the back pressure on high pressure side, shows plainly why the power of the engine is increased from 20 to 25 per cent. by converting the engine from compound to simple. No matter

There is an ordinary lavatory at one end of the car and an operating room at the other end, this room can be completely shut off from the "ward," which is in the center of the car, when an ample sliding door has been drawn across. The operating room

various other appliances for setting fractured bones and for easing a pain-racked limb. A plain, strong wooden table stands in the center of the room and with its head and foot extensions, makes a good operating table. A hinged side shelf suspended from the car wall can be swung up and used for holding instruments, etc., when serious work is being done. Two enamel douches hang on the walls between windows, and when fitted by the necessary rubber tubing can be used to pour an antiseptic wash upon an open and often unclean wound.

The "ward" of this hospital car occupies perhaps about three-quarters of its entire length and is furnished with cots which are wooden frames with stretched wire mattress netting covered with canvas and, upon this, the "bed" can be made. Each cot stands upon two pairs of folding legs, and the whole thing can be used as a stretcher. Two side doors like those of a baggage car permit the easy lifting of patients in and out of the ward part of the hospital. It is possible to comfortably accommodate sixteen persons in the ward and three more might be taken into the operating room if need be. There is a canvas hammock stretcher which can be slung diagonally across the car, if the motion of traveling was deemed too trying for a badly injured patient.

The company have their road divided up into districts and have from 28 to 30 available surgeons distributed at



PATIENT'S WARD IN LONG ISLAND RAILROAD HOSPITAL CAR.

whether working compound or simple, the crosshead pull will be equal on both sides of the engine as the piston areas multiplied by their respective pressures are equal in both cases.

With reference to the irregularities of this type of compound, the points to be taken up in subsequent issues are not unfolded with a view of shaking the confidence of any one, but simply to show the importance of posting the men who are expected to produce good results with this type of engine.

(To be continued)

The Long Island Railroad Hospital Car.

The Long Island Railroad has what was probably the one, only and original hospital car at the time it was built. This car has the distinction of having been built from the trucks up as a hospital car, and was not an old out of date coach adapted and made over.

It is, however, built on the general lines of an old-time passenger car and has ventilating screens between every second window as well as the ordinary ventilating sashes in the clearstory, and good ventilation is an important thing in a hospital car. There are also plenty of windows, with shades, and the car is painted white inside so that plenty of light may be had or it may be tempered as occasion requires. The car is lighted with Pintsch gas at night. There is not a trace of ornamental work inside, and the mouldings are plain and smooth so that they can be easily cleaned.

is equipped with a sterilizing apparatus for surgical instruments, etc., the water for which is heated by consuming Pintsch gas in a Bunsen burner. On one side of the car a medicine and in-



VIEW FROM OPERATING ROOM—LONG ISLAND RAILROAD HOSPITAL CAR.

strument chest is placed, the top of which comes level with the bottom of the windows. A supply cupboard placed against the partition contains rubber sheets, surgical dressing, first-aid boxes, overclothes for the operating physician, which are called gowns by the profession, and

various points along the line. Dr. George K. Meynen, of Jamaica, N. Y., is regularly in charge. The car stands usually in the Long Island City station, and in winter is coupled to the station steam heating plant and kept warm and

(Continued on page 566)

Of Personal Interest.

Mr. C. D. Morris has been made traveling engineer on the Norfolk & Southern Railroad, with headquarters at Berkeley, Va.

Mr. J. A. McRae has been appointed mechanical engineer of the Boston & Albany Railroad, with headquarters at Boston, Mass.

Mr. L. L. Collier has been appointed master mechanic on the Newton & Northwestern Railroad, with headquarters at Boone, Ia.

Mr. T. H. Goodnow has been appointed general foreman at Air Line Junction, Ohio, on the Lake Shore & Michigan Southern Railway.

Mr. George Keegan has been appointed assistant to the general manager of the Interborough Rapid Transit Company, of New York.

Mr. C. W. Carey has been appointed assistant air brake instructor on the Canadian Pacific Railway, with headquarters in Montreal.

Mr. W. C. Curtis has been appointed road foreman of engines on the Meadville Division of the Erie, vice Mr. A. L. Carskadden, promoted.

Mr. T. F. Brynes has been appointed assistant to the president of the New York, New Haven & Hartford Railroad, with office at New Haven, Conn.

Mr. J. A. Riley has been appointed roundhouse foreman on the Chicago & Alton, with office at Bloomington, Ill., vice Mr. W. L. Brooks, resigned.

Mr. D. R. Smith has been appointed road foreman of locomotives for the first district, Western Division, Canadian Pacific, with headquarters at Calgary, Alta.

Mr. Joseph Donahue, one of the St. Louis district dispatchers, has been made night chief on the Baltimore & Ohio South-Western, vice Mr. C. G. Stevens, promoted.

Mr. Clement F. Street has been appointed commercial engineer of the Westinghouse Electric & Manufacturing Company to handle work in connection with steam railroads.

Mr. D. McLean has been appointed road foreman of locomotives and acting trainmaster of the second district, Western Division, Canadian Pacific, with office at Cranbrook, B. C.

Mr. F. M. Gilbert has been appointed mechanical engineer of the New York Central & Hudson River Railroad, vice Mr. F. M. Whyte, promoted. Mr. Gilbert's office is in New York.

Mr. W. G. Innes has been appointed assistant road foreman of engines on the River Division on the Buffalo & Allegheny Valley Division of the Pennsylvania, with office at Phillipston.

Mr. Harold E. Morill, formerly master mechanic of the Monson Railroad Company, has been appointed superintendent of the same road, with office at Monson, Me., vice W. L. Estabrooke, deceased.

Mr. F. F. Gaines, master mechanic on the Lehigh Valley Railroad, at Wilkesbarre, Pa., has been appointed mechanical engineer of the Philadelphia & Reading Railroad, with headquarters at Reading, Pa.

Mr. S. King, formerly M. C. B. on the Intercolonial Railway, has been appointed assistant master car builder on the Canadian Pacific Railway for lines east of Port Arthur, with office at Montreal.

Mr. George Thomson has been appointed general foreman on the Indiana, Illinois & Iowa Railroad, with headquarters at Kankakee, Ill. He has charge of all matters pertaining to car department.

Mr. A. L. Carskadden, who has been road foreman of engines on the Meadville Division of the Erie Railroad, has been appointed trainmaster of the Meadville Division, east, with office at Meadville, Pa.

Mr. C. G. Stevens, who has served as night chief in the dispatcher's office, on the Baltimore & Ohio South-Western Railroad, has been given the position of chief dispatcher, vice Mr. E. C. Owens, promoted.

Mr. Grant Hall, formerly assistant superintendent of motive power on the Canadian Pacific Railway has been made assistant superintendent of motive power for lines West, with headquarters at Winnipeg, Man.

Mr. W. H. V. Rosing, formerly assistant superintendent of machinery on the Illinois Central, at Chicago, has accepted the position of mechanical engineer of the Missouri Pacific, with office at St. Louis, Mo.

Mr. J. A. Middleton has been elected first vice-president of the Lehigh Valley Railroad, with office at No. 143 Liberty street, New York, N. Y. He is in general charge of the company's passenger and freight traffic.

Mr. D. H. Deeter, master mechanic, of the Philadelphia & Reading, at Philadelphia, Pa., has been transferred as master mechanic on the same road, in charge

of the shops at Reading, Pa., vice Mr. R. Atkinson, resigned.

Mr. Joseph Chidley has been appointed assistant master mechanic of the Michigan Southern Division of the Lake Shore & Michigan Southern Railway, with headquarters at Elkhart, Ind., vice Mr. Peter Maher, resigned.

Mr. H. J. Beck, traveling engineer on the Lebanon Valley Division of the Philadelphia & Reading, has had his jurisdiction extended over the Reading Division of the same road, vice Mr. H. S. Hunter, promoted.

Mr. Charles Wilson, formerly general foreman of the Wilkesbarre shops of the Lehigh Valley Railroad, has been promoted to the position of master mechanic of the Wyoming Division, vice Mr. F. F. Gaines, resigned.

Mr. H. S. Hunter, formerly road foreman of engines, on the Reading Division of the Philadelphia & Reading, has been appointed master mechanic on the same road with headquarters at Philadelphia, vice Mr. D. H. Deeter, transferred.

Mr. John Magarvey, formerly assistant superintendent of the Brooks shops of the American Locomotive Works, at Dunkirk, N. Y., has been promoted to the position of superintendent of the works, vice R. H. Gilmour, deceased.

Mr. O. C. Gayley has recently been elected second vice-president of the Pressed Steel Car Company, of Pittsburgh, Pa. He will have charge of all sales departments and sales managers will report to him instead of to the president as heretofore.

Mr. E. G. Owens, who has been chief dispatcher on the Indiana and Illinois Divisions of the Baltimore & Ohio South-Western Railroad, has been appointed to the position of trainmaster in charge of the Indiana Division, succeeding J. C. Haggerty, promoted.

Mr. J. S. Doyle, formerly master mechanic of the electrical department of the Manhattan division of the Interborough Rapid Transit Company, of New York, has been appointed superintendent of car equipment for the whole Interborough system.

Mr. G. A. Hancock, superintendent of motive power, of the first and second districts of the St. Louis & San Francisco, has had his jurisdiction extended over the third district, vice Mr. G. W. Smith, who now has charge of the Chicago & Eastern Illinois.

Mr. F. M. Whyte, formerly mechanical engineer of the New York Cen-

tral, has been appointed general mechanical engineer, having jurisdiction over the N. Y. C., the B. & A., the L. S. & M. S., the Lake Erie & Western and the Indiana, Illinois & Iowa railroads.

Mr. E. A. Murray, formerly gang foreman in the Chesapeake & Ohio Railway, at Clifton Forge, Va., has been appointed general foreman of the same company's shops at Covington, Ky. Many improvements will be made in the Covington shops in the near future.

Mr. I. S. Downing has been appointed master car builder of the Michigan Southern Division of the Lake Shore & Michigan Southern Railway, and also has jurisdiction over the Indiana, Illinois & Iowa Railroad, with headquarters at Englewood, Ill., vice Mr. L. G. Parish, promoted.

Mr. F. T. Hyndman, formerly superintendent of motive power of the Buffalo, Rochester & Pittsburgh, at Du Bois, Pa., has been appointed general master mechanic of the New York, New Haven & Hartford Railroad, with headquarters at New Haven, Conn., vice Mr. F. B. Smith, resigned.

Mr. J. T. Flavin has been appointed assistant master mechanic on the Indiana, Illinois & Iowa Railroad, with headquarters at Kankakee, Ill. He has charge of all matters pertaining to locomotive department, vice Mr. Peter Maher, resigned to accept service with another company.

Mr. F. W. Brazier, heretofore assistant superintendent of rolling stock on the New York Central, has had the scope of his duties enlarged and his title changed to that of superintendent of rolling stock of the New York Central & Hudson River Railroad with jurisdiction over the Boston & Albany.

Mr. J. W. Platten has been elected second vice-president of the Lehigh Valley Railroad, with office at No. 228 South Third street, Philadelphia, Pa., and No. 143 Liberty street, New York, N. Y. He has charge of the financial and accounting affairs of the company and of its purchasing department.

King Edward has recently conferred the honor of Knighthood on Prof. William J. Sinclair, of Victoria University, Manchester, England. This distinction has been given as a recognition of national services rendered in the advancement of medical science. Sir William Sinclair is a younger brother of our chief editor, Mr. Angus Sinclair.

Mr. Le Grand Parish, heretofore master car builder with the Lake Shore & Michigan Southern, at Englewood, Ill., has been appointed assistant superintendent of motive power, with headquarters at Cleveland, Ohio. His jurisdiction is over the Lake Erie & West-

ern, the Indiana, Illinois & Iowa and the Lake Erie, Alliance & Wheeling railroads.

Mr. J. C. Haggerty has been appointed superintendent of the Indiana Division of the Baltimore & Ohio Southwestern Railroad, with headquarters at Cincinnati, Ohio, succeeding Mr. W. B. Poland, who resigned to accept a position in Alaska. Mr. Haggerty has been with the old Ohio & Mississippi and its successor, the B. & O. S. W., for thirty-five years, and has risen from the position of section laborer to that of superintendent, having served as telegraph operator, dispatcher, chief dispatcher and trainmaster.

Mr. Peter Maher has been appointed superintendent of motive power of the Toledo, St. Louis & Western, with headquarters at Frankfort, Ind. Mr. Maher has been assistant master mechanic of the Lake Shore & Michigan Southern for some time, having been master mechanic of the Indiana, Illinois & Iowa before that road was absorbed by the Lake Shore. Mr. Maher was noted as a master mechanic for his success in carrying on work under the difficulties of meager facilities. On the Lake Shore he made his mark as an excellent shop manager.

Mr. John Howard, superintendent of motive power of the Boston & Albany, has, in addition to his duties on that road, been appointed superintendent of motive power of the New York Central & Hudson River Railroad. Mr. Howard began railroad work as an apprentice on the Pennsylvania, at Renovo. In 1883 he went to the West Shore road as machinist; shortly afterwards he was made engine inspector and subsequently became roundhouse foreman at Frankfort. Seven years later he was appointed general foreman, and in 1892 was promoted to the position of master mechanic at New Durham, N. J. In 1901 he was made division superintendent of motive power and rolling stock on the New York Central, at Corning, N. Y. In a short time he was transferred to Depew, as division superintendent of motive power and less than a year ago was appointed superintendent of motive power of the B. & A. Mr. Howard's office is now in New York.

Mr. John Mailer, formerly master mechanic of the Minnesota & Northern Wisconsin Railroad, has been appointed master mechanic of the Fort Smith & Western, with office at Fort Smith, Ark., vice Mr. K. P. Alexander resigned.

Obituary.

C. F. Thomas, widely known in the mechanical circles of this country, died in Albuquerque, New Mexico, last October. Mr. Thomas entered the Pennsylvania shops at Renova, Pa., as an apprentice in 1875. After serving his

apprenticeship, he accepted a position with the Mobile & Montgomery, and in 1880 entered the service of the L. & N. as general foreman at Nashville, Tenn. He was in the service of many of our principal roads, holding increasingly responsible positions as time went on. In September, 1902, he entered the service of the American Locomotive Co. as general inspector at their Richmond works. Pulmonary troubles having developed, he resigned January 1, 1904, and accepted an offer made him by the Baldwin Locomotive Works, for special work in California and New Mexico, in which he was engaged at the time of his death. Mr. Thomas was a member of the Master Mechanics' Association and the Master Car Builders' Association, and took an active part in these societies, having done efficient work on a number of committees. He possessed an extraordinary knowledge of mechanical matters, and being a great student kept fully abreast of the times, especially as to economical shop practices. His thorough knowledge of all trades connected with maintenance of railroad equipment made him a most valuable manager. He designed many improvements and invented many of the "shop kinks" now in common use. His sturdy honesty, unselfish character and loyal friendship, endeared him to those who knew him.

Elliptical Instead of Circular.

The latest Vanderbilt tank is elliptical in cross section and this form has some advantages over the circular type. In the first place it is about as easy to build and will hold more water for a given length than the tube tank. It also brings the manhole for filling lower than that on the circular tank, which is a decided advantage on many roads. The tube and the oval form of tank are not as expensive to construct as the forms commonly used.

R. D. Wood & Co., of Philadelphia, have issued two illustrated catalogues, one is concerned with high-grade centrifugal pumping machinery and the other with gas for power and fuel. They are editions which contain the description of this company's exhibits at the St. Louis exhibition. They comprise among other things a large centrifugal pump capable of delivering 50,000 gallons per minute, motor-driven centrifugal pumps, etc., glossary of terms and instructions for inquiries or orders, formulas and tables. The catalogue on gas making and using installations, shows gas holders, producers, gas-power plants and high-duty pumping engines. Either or both of these catalogues will be sent to any address on application to the company.

The Inside Admission Piston Valve.

Our illustrations are taken from the pages of the American Locomotive Company's catalogue. Fig. 1 shows at a glance how the piston valve can be placed most satisfactorily in the cylinder casting almost straight above the frame seat. The valve here shown is of the inside admission type, and such a valve has the advantage not only of being perfectly balanced, but the valve stem packing only encounters the comparatively low and intermittent pressure of exhaust steam. The piston valve enables designers readily to reduce clearance by making short direct steam ports and the inside admission valve aids very considerably in this direction.

Company's exhibits, or, one might say, as one of the object lessons on the construction of piston and by-pass valves.

Sound Sentiment.

The sound Christian truths that we are conscientiously as well as duty-bound to carry through the details of our everyday life is well illustrated in the well chosen moral quotations in RAILWAY AND LOCOMOTIVE ENGINEERING. The one on page 483 of the November issue, which says: "It is easy to be good when there is no temptation to be bad. Many a saintly life follows the path of righteousness because the entrance to the other path was never encountered," conveys a whole world of truth, and in no path is this more the truth than in

replacers are made with the intention of causing a wheel to grip when it comes on, and thus avoid the danger of pushing the replacer out of position or of slipping. If you want any information regarding the Buda replacers, write for this bulletin and the company will be happy to send you one or to give you information concerning their other railroad specialties.

The Baldwin Locomotive Works have received an order from the Atchison, Topeka & Santa Fe for eighteen Atlantic type locomotives with balanced compound cylinders. These engines are duplicates of those previously furnished.

The Delaware, Lackawanna & Western Railroad people do not find that the

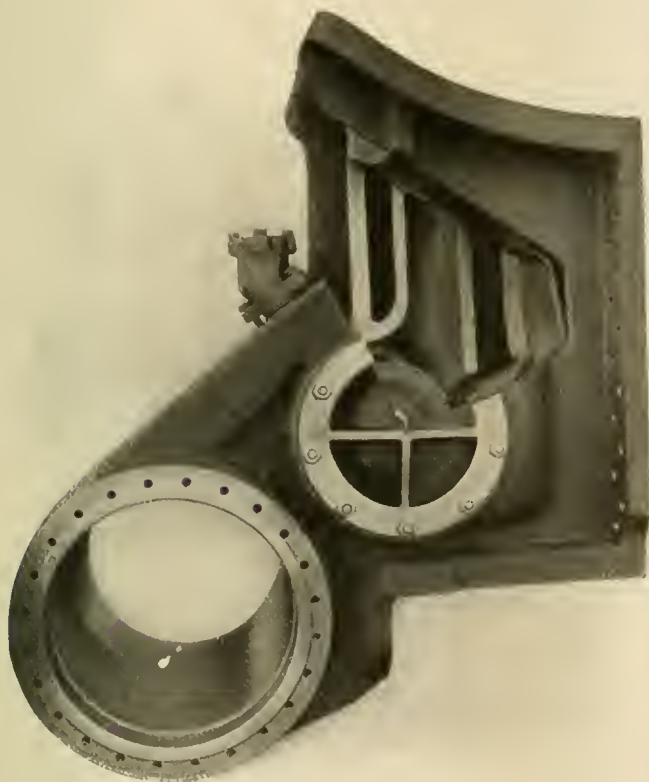

FIG. 1.—CYLINDER AND PISTON VALVE

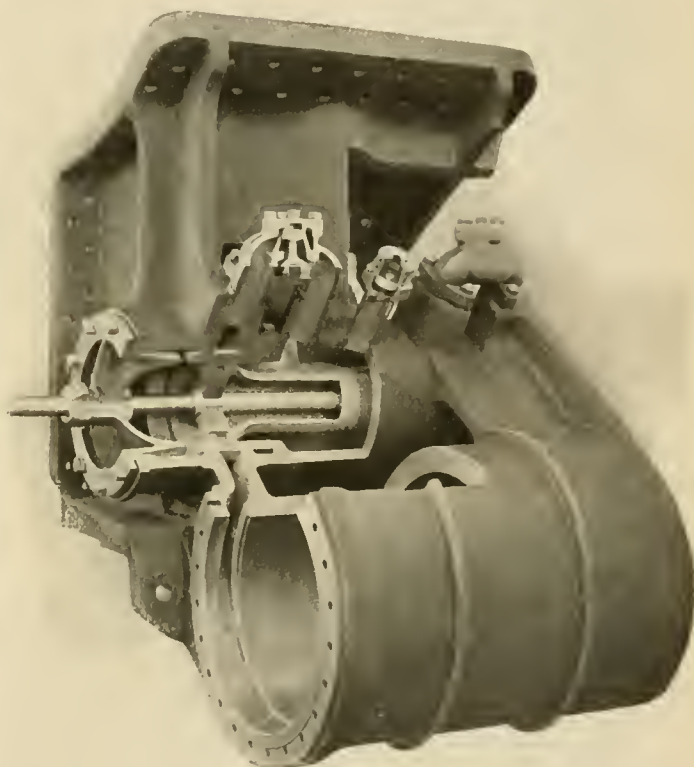

FIG. 2.—PISTON VALVE AND BY-PASS VALVES.

In Fig. 2 a section of the valve itself is shown and also a section of the by-pass valves. These relief valves perform the important functions of letting water in the cylinders escape to the atmosphere before doing damage, and when the engine is drifting these valves open an unbroken passage from one end of the cylinder to the other, through which air circulates. The by-pass valves are held up to their seats by live steam pressure, and when that is cut off they drop open by the action of gravity.

At the St. Louis Exposition a full-sized cylinder and saddle cut as shown in the two views here given was used as one of the American Locomotive

the temperance question, which evil, happily, is much abated of late years.

H. W. GRIGGS.

One of the bulletins of the Buda Foundry & Manufacturing Company, which we have lately seen, deals with the Buda Car and Engine Replacer, and we illustrate the device for the benefit of our readers. Both replacers have pointed caulks, but the inside one, which does all the pulling toward the track, can be spiked down if necessary, and if spiked, it can be readily and quickly drawn out from under the spikes when occasion demands. These are the kind of things which count for a great deal when one is in a hurry to get the line clear. These

piston valve improves the efficiency of their heavy engines. They are removing them and putting in balanced slide valves as the engines go into the shops for repairs.

The U. S. Government has just purchased from Rand Drill Co., 27 Imperial pneumatic hammers and drills. These are to be used in connection with the Manila Harbor improvements.

No work is worth doing badly, and he who puts his best into every task that comes to him will surely outstrip the man who waits for a great opportunity before he condescends to exert himself.
—J. Chamberlain.

Long Island Railroad Hospital Car.

(Continued from page 562.)

always ready for immediate use. Outside it is finished according to the railroad standard, and is designated by a letter of the alphabet, like other special cars. In this case the letter E stands for the hospital car, which, we may not be very far wrong in associating with the initial letter of the word "emergency," for it is certainly a very complete emergency car.

In thus providing very fully for serious contingencies, the Long Island Railroad has acted upon the motto, "In peace, prepared," which, of course, does not mean that war must follow such preparedness. In thus having an emergency outfit, the railroad does not look for, or expect disaster. In fact, such handling of detail and organizing and systematizing of relief methods may reasonably argue the existence of the same care and intelligent forethought in other departments more closely connected with railway operation. A properly equipped hospital car may not often be needed, but when it is required in earnest it is by far the most important feature of the wrecking train.

Again, it may be said that permanent surgical work or difficult operations would not as a rule be performed in the operating compartment on the car, and in ordinary cases first aid methods would be employed until regular hospital treatment could be had. While this is true, there is no denying that cases might arise where vigorous and prompt treatment would become imperative, and then the presence of a well lighted, comfortably warmed, convenient, fully equipped and clean hospital car would be a veritable god-send to sufferers on an inclement winter night, when otherwise well intentioned efforts must prove futile. The hospital car on railways is not a picturesque advertising "feature;" it is on land what a staunch and capably manned lifeboat is at sea.

Defending the Fireman.

In the course of discussions at the last Railway Master Mechanics' Convention Angus Sinclair, editor of *LOCOMOTIVE ENGINEERING* remarked:

When a modern fireman is required to handle as much coal as a laborer is required to throw out of a car per day's work, it is not surprising that the ordinary run of intelligent men should keep away from the employment of fireman, if possible. At the best nowadays, a fireman's work is exceedingly arduous. It is work which only selected men of great physical power can be expected to go through successfully. Under ordinary circumstances, a fireman has to shovel an immense quantity of coal when an engine

is working at its hardest, and he has to make several movements before he gets the coal in the place where it is to go. Everything ought to be done to help that man so that there should be no unnecessary increase of labor laid upon him. The coal should be moved forward at water stations, and the help of the men on the front of the train, perhaps the head brakeman, ought to be enlisted to help the fireman, but that practice is very much neglected, to say the least about it. It is theorized over as being a very desirable thing, and on some roads the practice is followed; but as a general thing it is very much neglected, and so long as the fireman can be kept on engines throwing the coal in the fire box—it does not matter very often how it is put in—the roads get along and let the fireman take the brunt of the work, and then they complain that firemen are not as efficient as they used to be. It cannot be expected that firemen will be efficient considering the amount of work they have to do.

In regard to the automatic stoker, that is coming; but there is about the same spirit in regard to it that there is about helping the fireman. There have been good automatic stokers produced, but there is no inclination on the part of the railway officials as a whole to make the best of them. If the fireman actually could not get along firing the engines any longer, our motive power men would find ways to develop the automatic stoker so that it would be as efficient as any other part of the mechanism of the engine. The reason the stoker is not properly developed is that the railroads are not very anxious for it, as it increases the first expense of running a locomotive.

I have devoted a great deal of attention to automatic stokers ever since an attempt was made to introduce them, and the only serious objection that I have heard raised against them is that the device is not properly developed. That is an objection which has been raised against every device that I know of that has been introduced in connection with locomotive mechanism. Those who can go as far back, and perhaps a little further back than I can, remember that when first introduced there were a great many difficulties with valve motion, and certain other inventions and appliances were considered failures, or very nearly so. I have heard men say on the floor of a convention of this association, that a balanced valve was naturally a failure and never would be a success. I have heard the meanest kind of talk about injectors—that they were never so good as a pump, that they would never be so reliable and never would be a success. When power brakes began to come in first we heard the same kind

of objections—the thing many people said will never be a success.

Now, in regard to these things, there had been difficulties at the start, but the difficulties were overcome by the ingenuity and good sense of the mechanics connected with railroad engineering mechanism. In my opinion, if the same earnestness were devoted to make the automatic stoker a success that has been devoted to the other mechanism that were considered failures originally, and then became very great successes, the same thing will apply in the case of the automatic stoker—it will eventually be made a very great success.

Steel Passenger Cars.

The Standard Steel Car Company are building some all-steel passenger cars. The first of the kind is an all-steel postal car which conforms in all needed particulars to M. C. B. standards. Baggage and express cars, which, like the post office cars, are likely to encounter rough treatment in derailment and wreck, are also to be made of steel.

Mr. J. J. Esch, a member of the House Committee on Interstate Commerce, introduced a bill at the last session of Congress to compel railroads to strengthen their passenger and baggage and mail construction. The Pullman is taken as the standard and its behavior in a wreck has been made the subject of statistical investigation.

In three years previous to September 30, of this year, the Pullman Company carried 32,693,341 passengers, and in that time only six were killed and sixty-four were slightly injured. During the year ending March 31, there were more rear than butting collisions, and from this it is argued that it is in the greater strength of the Pullman car that safety is to be found.

The only rational practice in railroad operation is to remove the cause of collisions whether front or rear, but there are other considerations which ought to bring the all-steel coach into favor on American roads. These cars can be made lighter and their maintenance should cost less than wooden cars, and as they come into more general use, and as more of them are built, their first cost should be reduced so that both in the matter of economy and long life and in removing the danger of fire in case of emergency, and with a reserve of strength, the all-steel passenger and mail and baggage car is a very desirable form of car construction.

When you hear a man bemoaning the interestedness of friendships, it is safe to assume that he has just tried, unsuccessfully, to get something from his friend.—*W. M. Blatt, in the National Magazine*

Signals and Signaling.

BY GEORGE SHERWOOD HODGINS.

(Continued from page 494.)

ELECTRIC TRAIN TABLET BLOCK SYSTEM FOR WORKING ON SINGLE LINE OF RAILWAY, AS USED ON THE HIGHLAND RAILWAY OF SCOTLAND.

The object of the system of electric train tablet signaling is to prevent more than one train being between any two tablet stations at the same time, and when no train is on the section between two tablet stations, to admit of a train being started at either end. This is accomplished by every train, having the right to be in the block, carrying a tablet, which tablet is obtained from the tablet instrument, and this is under the control of the station master, signalman or other responsible person. When the tablet

train tablet instruments are worked, and the mode of indicating descriptions of approaching trains are laid down in a number of regulations and in a code of signals applicable thereto. An apparatus is provided at stations, and also on the side of engines for exchanging tablets between signal man and engine driver. This apparatus consists of a fixed iron standard erected in a suitable position

to suit the locking mechanism of the tablet instrument and has the names of the two stations cast or engraved on the brass-faced side, as shown in our illustration. It also bears a heavy-type number, about $\frac{3}{4}$ of an inch deep, which indicates the particular block to which it belongs.

When this tablet or medal, as it may be called, is legitimately withdrawn from



STATION PILLAR SET READY FOR EXCHANGE.

is withdrawn from the instrument this electrically controls the whole of that section either up or down, as one tablet only can be obtained from the tablet instruments of the same section or block at the same time.

The tablet is a flat circular disk with the names of the tablet stations at either end of section engraved thereon, and with a hole cut in the center to suit the tablet instrument, which hole is of different formation for each section. The internal arrangement of train tablet instrument is such that a tablet, belonging to one section, cannot be placed in the instrument belonging to another section.

The system under which the electric

other. A somewhat similar arrangement is placed on the engine, the catcher being carried on a hinged arm fixed to side of the cab, but with the position of spring catcher and delivery spring reversed.

The tablet is a circular disk, $4\frac{1}{2}$ ins. in diameter, made of aluminum faced with brass on one side. It is perforated

edges. It is about 7 ins. wide by 8 ins. deep, and is again sewed at the bottom to conform with the curvature of the lower half of the tablet.

When the tablet is dropped into pouch a notch in the table helps to prevent it turning and holds the number opposite an appropriate slot cut in the leather



TABLET CATCHING EQUIPMENT APPLIED TO ENGINE.

on the left hand side of both up and down lines, and carrying a sliding top operated by a handle. To this slide is affixed a cross arm with a spring catcher at one end and a delivery spring at the

tablet instrument at the entrance to a block, it is put into a leather pouch, made as shown in Fig. 3. This pouch is made of tough leather flanged top and bottom and strongly sewed on the



IN THE ACT OF EXCHANGING TABLETS.

case, so that the number is always visible without removing the tablet from the pouch. The pocket cover or top of the pouch fits the upper curvature of the tablet and its pressure on the metallic disk also helps to prevent rotation and keeps the designating number opposite the slot

to become careless and thus defeat the object of the tablet system, which is absolute safety and unimpeachable right of track, but this cannot be the case, because the station master cannot get more than one tablet out of an instrument at a given time, and in doing so he locks

possibility of misunderstanding and there is no ambiguity in the system.

The exchange operation, with a train in motion, may briefly be described as follows: When a tablet has been obtained from the tablet instrument it is put into a leather pouch, with lid, then the pouch, with tablet, is placed in the delivery springs, attached to the arm which is screwed to the catcher, on the ground or station standard. The handle is drawn back in order to set the slide full forward to the stop. This sets the catcher to exact gauge, and ready for exchange, and must be so held in position until exchange takes place. A pouch with tablet is also placed in delivery springs on the engine catcher in a like manner to the station one, and the arm is lowered before the train approaches the fixed iron standard. The exchange then takes place instantly. Care has to be taken to see that the pouches with tablets in them hang plumb and are fully down, with lids on top. The whole system is worked most expeditiously and absolute safety in train operation is thus guaranteed alike to employees and to the patrons of the road.

(To be continued)

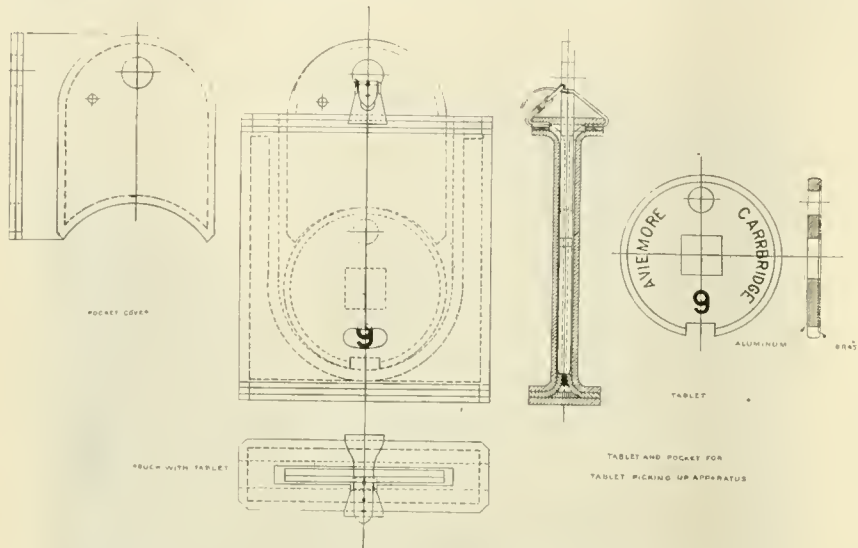

FIG. 3.—LEATHER POUCH AND TABLET USED ON THE HIGHLAND RAILWAY OF SCOTLAND.

in the pouch. This pouch-cover has a circular finger hole at the top through which a leather strap is passed and buckled so that it cannot come out. When all is ready it is placed on the station pillar and it is then ready to be caught by the train entitled to proceed.

the instrument at the other end of the block.

When a tablet is picked up by a moving train it must be taken out of the "pick up" clutch by the engine driver or fireman and placed in the "delivery clutch" while they are passing through

A remarkably handsome and artistic calendar has been published by the *Automobile Magazine* which adds a spot of joy to the room or office where it is put up. Two leading personages are in the picture, a young man catching a glass of water from a rustic rill and a handsome young woman waiting in

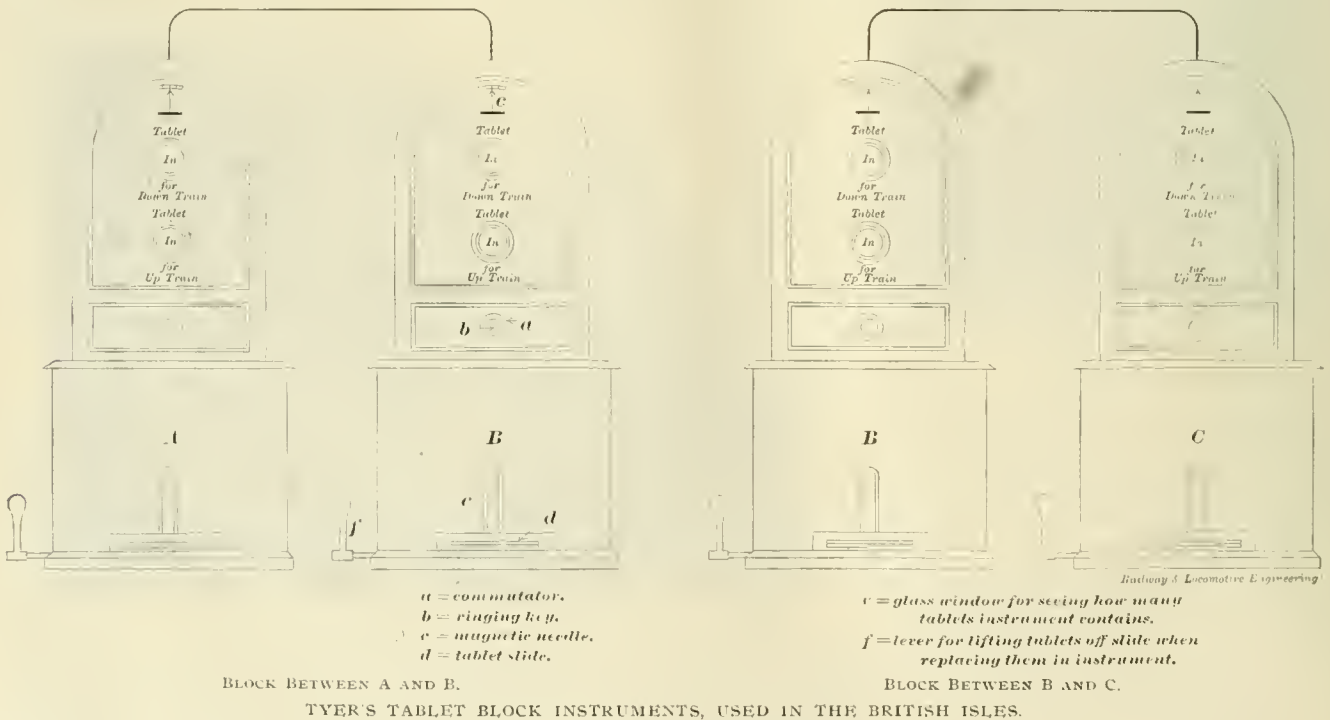

At first sight it might appear as if the catching and delivering of these tablets by automatic contrivances on a rapidly moving train might cause the men concerned in the safe movement of trains

the block, and this enables them to examine the number which shows through the slot in the pouch or take the tablet out and read the names of the stations at each end of the block. There can be no

an automobile to quaff the cooling draft. People wishing to have this pretty calendar can have it by sending ten cents to Frank A. Egan, 136 Liberty street, New York.

Pressed Steel Tank Car.

Our illustration shows a tank car built by the Pressed Steel Car Company, of Pittsburgh, for the Freedom Oil Works Company, of Freedom, Pa.

The tank itself is 79 $\frac{5}{8}$ ins. inside diameter at the center and is 26 ft. 6 ins. long, measured from center to center of outside rivets at heads. The tank contains 7,000 gallons and the rated capacity of the car is 60,000 lbs. The tank itself weighs 9,515 lbs. The underframe straps, bands, etc., weigh 12,660 lbs. and the dead weight of the trucks is 11,816 lbs. The total weight of the car is, therefore, 34,000 lbs. The cars are equipped with safety valves according to the Pennsylvania standard.

The car is held in place by four pressed steel brackets on each side and four bands, one from each bracket, pass over the body of the tank. These bands have adjustable turn buckles. There are two

low seams except here safety from an explosion of fire-damp gives the advantage to the air motor. The delays incident to charging are not so very serious, as even in the best managed establishments there is more or less time lost at terminals which may be utilized for charging. Any extra work between charging stations is liable to exhaust the supply of air in the tanks and necessitate a run to the charging station. These are some of the disadvantages of air operated locomotives.

On the other hand electricity has never been successfully applied to the gathering of cars from mine rooms or working places owing to the expense involved in wiring each place and also the difficulty of passing round short curves without displacing the trolley. A compressed air locomotive is very successful for this purpose. The small gathering locomotive has the same dimensions as the

one time, though at other times it may be run under light load. No such plant can be economically run in that way and to provide means to suddenly meet the maximum demand involves large first cost.

In the pneumatic system, the elasticity of the air provides for this excessive demand, and distributes the work over a considerable time. This permits the installation of a smaller plant, and allows of adjustment to an even rate of energy production, which is very conducive to economy of operation.

The Joseph Dixon Crucible Company, of Jersey City, have issued a neat little folder dealing with the protection of steel. They say the presence of sulphurous gases, cinders and steam, combined with exposure to the elements provide conditions favorable to the corrosion of



PRESSED STEEL TANK CAR. 7,000 U. S. GALLONS CAPACITY.

bands, one at each end which pass through the pressed steel end sockets, which latter prevent end motion of the tank on the deck of the car. Fox pressed steel trucks are used. The car framing is light and strong and the car presents what one might call a neat and workmanlike appearance.

Electric and Compressed Air Mine Locomotives.

A paper was read not long ago before the Institution of Mining Engineers, by Beverly S. Randolph, at a general meeting held in London, on the comparison of electric and compressed air locomotives in American mines. Some extracts may be of interest.

The writer believes that either form of locomotive is entirely a question of conditions. For example, the main hauling pneumatic locomotive is large and cumbersome and not well adapted to

mine cars and can run on any road that they can. The machinery of air-operated engines is like that used with steam, so that mechanics who are familiar with the one have little to learn in managing the other, and men who can handle air are easily obtainable.

In the matter of installation, the electric plant is usually the more expensive. The cost of the two kinds of locomotive does not leave much to choose from. Comparing pipe and transmission wire, the wire is cheaper for short distances, but its cost increases as the square of the distance, while the cost of the pipe line increases directly as the cost, and, therefore, beyond a certain distance the wire must become the dearer of the two.

The greatest difference is found in the cost of generation of power. In an electric installment, the plant must at all times be able to meet the greatest demand that can be brought upon it at any

steel work. A half-tone engraving of the Willis Avenue bridge over the tracks of the N. Y., N. H. & H., in New York, is given on one page of the folder which shows the excellent condition of the Dixon's Silica-Graphite paint on this structure after four years' exposure under the conditions mentioned above. It is an object lesson, as Jim Skeevers would say, on the resisting qualities of this paint. The Joseph Dixon people will be glad to send a copy of this folder to anyone who will apply to them for it.

Any person thinking of going fishing or hunting in the South during the winter ought to apply to W. H. Taylor, general passenger agent Southern Railway, Washington, D. C., for the pamphlet, *Hunting and Fishing in the South*. It is a perfect handbook on the subject.

Lodge & Shipley Projectile Lathe.

The lathe here illustrated is called by the makers a projectile turning lathe, but it will do any work which a strongly made first-class lathe will do in a railroad shop. It has the Lodge & Shipley patent head and is electrically driven.

The motor is a Ridgeway 15 h.p. with speeds of 350 to 1,750. The controller has 20 speeds, and is operated from the carriage, or at the headstock. The ratio of back gearing in the head is 1.02 to 1 and 2.62 to 1; the ratio of the motor shaft to the live spindle is 7.48 to 1 and 15.1 to 1. All gearing in the head, that is, the main driving gears, are cast iron centers, with machinery steel rims of extra width. The size of the spindle bearings are: Front, $7\frac{7}{8}$ ins. diameter by $8\frac{3}{4}$ ins.; back, $7\frac{1}{2}$ x $5\frac{5}{8}$ ins. The spindle is of crucible steel, .55 per cent.

eter gauges shown on the nose of the tailstock, which in practice are great economizers of time. This lathe is of 27 ins. swing; the length of bed can be varied to suit the customer; the one here shown has a 14 ft. bed.

The starting and stopping mechanism is very handy, there being two upright spindles with hand wheels on top, one on the carriage which moves as the carriage advances, and the other is stationary. The operator does not have to leave his work to start or stop the machine; an automatic stopping device on the carriage can be set to stop the lathe when desired. The Lodge & Shipley Machine Tool Company, of Cincinnati, Ohio, are the makers.

The Falls Hollow Staybolt Company, of Cuyahoga Falls, Ohio, have received

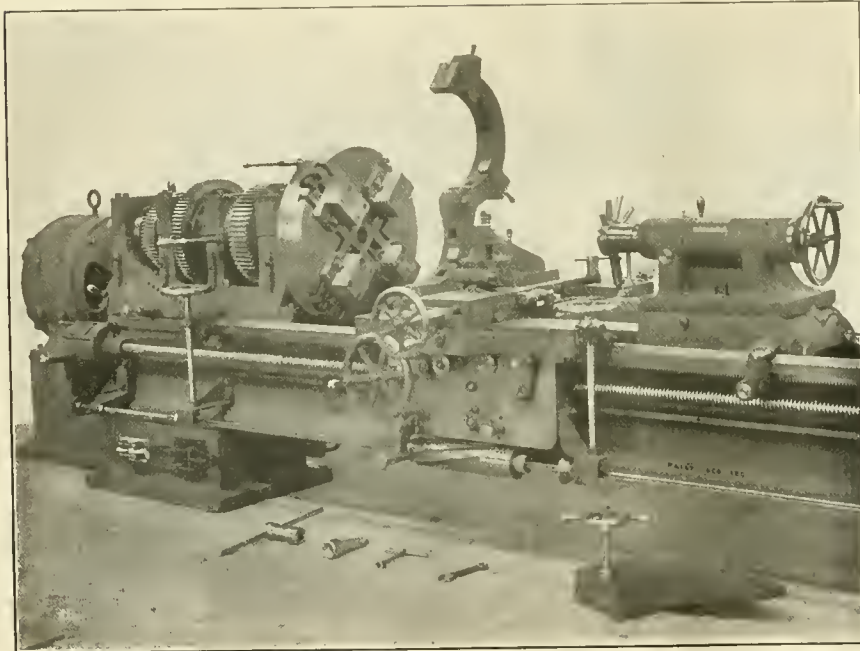

SIDE VIEW ELECTRICALLY DRIVEN LATHE, BUILT BY LODGE & SHIPLEY.

carbon; the hole through the spindle is $2\frac{3}{8}$ ins. diameter.

The lathe is designed, at minimum speed of motor, to have a cutting speed for roughing on the body of a shell of 30 ft. per minute and for finishing of 60 ft. per minute. The milled cylinder on the speed control shaft, immediately under the apron, provides an automatic mechanical and full electrical speed variation for differing diameters, so that the cutting speed may be continuous from 2 ins. diameter up to the largest diameter.

The tool post is of steel, and there is a special steady rest which is quickly applied or removed, also radial attachments for furnishing several desired curves. The chuck is of massive and substantial design. A notable feature is the diam-

an order from the Kiushiu Railway Company, of Japan, for 28,000 lbs. $1\frac{1}{8}$ in. outside diameter by $\frac{1}{8}$ in. inside diameter; 18,000 lbs. $1\frac{1}{4}$ in. outside diameter, by $\frac{1}{8}$ in. inside diameter; 1,200 lbs. $1\frac{3}{8}$ in. outside diameter, by $\frac{1}{8}$ in. inside diameter, Falls Hollow Round Bars, 10 ft. long, to be made of the same quality high grade double refined charcoal iron. The Kiushui Railway Company have made severe service tests of this staybolt iron, which have resulted satisfactorily and are now ordering in carload lots. Large quantities of hollow bars are being shipped to other railroads of Japan and to the Japanese Government. The Norwegian State Railway Company are using Falls Hollow iron exclusively for staying the fire boxes of their locomotives.

Yours for the asking



This interesting and instructive book covers the chief points of the theory of

Graphite Lubrication

and tells many of its practical benefits.

It is written to interest and instruct practical men, and to bring about a clearer understanding of the sound principles which underlie the use of

Lubricating Graphite

It is an advertisement, but it is more than that—

“Graphite as a Lubricant”

is the most complete and accurate text book on this important subject in English or any other language. It is an advertisement only in the fact that it recommends the use of

Dixon's Ticonderoga Flake Graphite

which all men know is the only graphite thoroughly fit for lubricating purposes.

Send for a free copy of this book and samples if you know what “friction trouble” means.

**JOSEPH DIXON
CRUCIBLE CO.
Jersey City, N. J.**

Vulcabeston

MOULDED

CONVEX and
CONCAVE RINGS



Pronounced by Superheat Experts
After Exhaustive Tests

The Only

RELIABLE

PACKING

for

SUPERHEATED STEAM

NOTE:—Fit stuffing box without up-
setting; hold tight without pinching

BEATS ALL OTHERS

FOR HIGH PRESSURE
STEAM, OIL, AIR, ACIDS

Send for Samples and Full Information

H. W. Johns=

Manville Co.

100 WILLIAM STREET
NEW YORK

Milwaukee	Cleveland	Boston
Chicago	Pittsburg	Philadelphia
St. Louis		London

"As You Like It."

A curious case of "improving upon Shakespeare" is credited to a zealous proofreader who, in going over galleys of an edition of the immortal bard's works, found this line in the first scene in the second act of "As You Like It": "And this our life, exempt from public haunt, find tongues in trees, books in the running brooks, sermons in stones, and good in everything." He let "tongues in trees" stand, but altered the next sentence to read "Stones in the running brooks, sermons in books and good in everything." It is easy to see that this very literal change destroyed the meaning of the whole passage. As Shakespeare wrote the lines, they refer to the instruction and pleasure which can be derived from the study of Nature, and to the satisfying variety which Nature presents to those who have the power to perceive aright.

We cannot help referring to the proofreader's humorously correct idea of finding sermons in books. The idea is all right as far as it goes, but it also seems to imply that those kind of books would be rather dry reading, and it is on that account that we desire to point to a certain list of books which are as fresh and clear as those which Shakespeare said could be read in the running brooks in the forest of Arden. They are not books of sermons but practical works on subjects that interest you.

The first on the list is, of course, RAILWAY AND LOCOMOTIVE ENGINEERING, a practical journal of railway motive power and rolling stock. It costs only \$2.00 a year, and is well worth the

money, and besides the paper is a welcome visitor in every household. Let your wife and children see it.

"Twentieth Century Locomotives," Angus Sinclair Co., deals comprehensively with the design, construction, repairing and operating of locomotives and railway machinery. First principles are explained. Steam and motive power is dealt with, workshop operations described, valve motion, care and management of locomotive boilers, operating locomotives, road repairs to engines, blows, pounds in simple and compound engines, how to calculate power, train resistance, resistances on grades, etc. Shop tools explained. Shop receipts, definitions of technical terms, tables, etc. Descriptions and dimensions of the various types of standard locomotives. The book is well and clearly illustrated and is thoroughly up to date in all particulars, fully indexed. Just off the press. Price, \$3.00.

"Locomotive Engine Running and Management," by Angus Sinclair, is an old and universal favorite. A well-known general manager remarked in a meeting of railroad men lately, "I attribute much of my success in life to the inspiration of that book. It was my pocket companion for years." We sell it for \$2.00.

"Practical Shop Talks," Colvin. This is a very helpful book, combining instruction with amusement. It is a particularly useful book to the young mechanic. It has a stimulating effect in inducing him to study his business. The price of it is 50 cents.

"Examination Questions for Promo-

THE LONG & ALLSTATTER CO.

Designers and Manufacturers of

HAMILTON, OHIO

Power Punching and Shearing Machinery

OF ALL KINDS AND SIZES

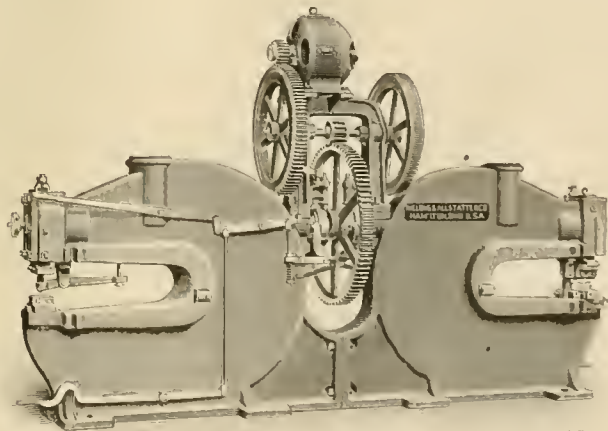

675

MOTOR DRIVEN, DOUBLE PUNCH AND SHEAR

- Riveting Machines
- Armature Disc
- Notching Machines
- Tire Welding
Machines
- Beam Coping
Machines
- Bending and
Straightening
Machines
- Drop and
Helve Hammers

Write If Interested
Correspondence Solicited

tion." Thompson. This book is used by many master mechanics and traveling engineers in the examination of firemen for promotion and of engineers likely to be hired. It contains in small compass a large amount of information about the locomotive. Convenient pocket size. We cordially recommend this book. The price is 75 cents.

The 1904 Air Brake Catechism. Conger. Convenient size, 202 pages, well illustrated. Up to date information concerning the whole air brake problem, in question and answer form. Instructs on the operation of the Westinghouse and the New York Air Brakes, and has a list of examination questions for engineers and trainmen. Bound only in cloth. Price, \$1.00.

"Compound Locomotives." Colvin. This book instructs a man so that he will understand the construction and operation of a compound locomotive as well as he now understands a simple engine. Tells all about running, break-downs and repairs. Convenient pocket size, bound in leather, \$1.00.

"Catechism of the Steam Plant." Hemenway. Contains information that will enable a man to take out a license to run a stationary engine. Tells about boilers, heating surface, horse power, condensers, feed water heaters, air pumps, engines, strength of boilers, testing boiler performances, etc., etc. This is only a partial list of its contents. It is in the question and answer style. 128 pages. Pocket size. 50 cents.

"Care and Management of Locomotive Boilers." Raps. This is a book that ought to be in the hands of every person who is in any way interested in keeping boilers in safe working order. Written by a foreman boilermaker. Also contains several chapters on oil burning locomotives. Price, 50 cents.

"Locomotive Link Motion." Halsey. Any person who gives a little study to this book ceases to find link motion a puzzle. Explains about valves and valve motion in plain language, easily understood. Price, \$1.00.

"Machine Shop Arithmetic." Colvin and Cheney. This is a book that no person engaged in mechanical occupations can afford to do without. Enables any workman to figure out all the shop and machine problems which are so puzzling for want of a little knowledge. We sell it for 50 cents.

"Firing Locomotives." Sinclair. Treats in an easy way the principles of combustion. While treating on the chemistry of heat and combustion, it is easily understood by every intelligent fireman. The price is 50 cents.

"Skeevers' Object Lessons." Hill. A collection of the famous object lesson stories which appeared in this paper several years ago. They are interesting,

laughable, and, best of all, they are of practical value to-day. \$1.00.

"Stories of the Railroad." Hill. Best railroad stories ever written. Those who have not read these stories have missed a great literary treat. \$1.50.

"Standard Train Rules." This is the code of train rules prepared by the American Railway Association, for the operating of all trains on single or double track. Used by nearly all railroads. Study of this book would prevent many collisions. Price, 50 cents.

"Mechanical Engineers' Pocket Book." Kent. This book contains 1,100 pages 6x3¼ inches of closely printed minion type, containing mechanical engineering matter. It ought to be in the bookcase of every engineer who takes an interest in engineering questions. We use it constantly as a reference for questions sent to us to be answered. Full of tables and illustrations. Morocco leather, \$5.00.

"Locomotives, Simple, Compound and Electric." Reagan. An excellent book for people interested in any kind of locomotive. It will be found particularly useful to men handling or repairing compound locomotives. It is the real locomotive up to date. \$2.50.

RAILWAY AND LOCOMOTIVE ENGINEERING. Bound volumes. \$3.00.

1904-5 Officers of the New York Railroad Club.

The officers elected at the last annual meeting of the New York Railroad Club are as follows: President of the Club, Mr. H. H. Vreeland, who is president of the New York City Railway Company. Mr. J. F. Deems was elected first vice-president of the Club. He is general superintendent of motive power of the New York Central Lines. The Club's second vice-president is Mr. W. L. Deer, the chief engineer of the Erie Railroad. The third vice-president is Mr. W. G. Besler, vice-president and general manager of the Central Railroad of New Jersey.

The executive committee is composed of Mr. Geo. W. West, superintendent of motive power of the New York, Ontario & Western, whose term is for three years; Mr. Frank Hedley, general manager of the Interborough Rapid Transit Company, who serves for two years; and Mr. William Mackintosh, superintendent of motive power of the C. R. R. of N. J., who remains on the committee for one year.

The finance committee is made up of Mr. R. L. Thomas, of B. M. Jones & Co., New York. He serves for three years. Mr. O. C. Gayley, vice-president of the Pressed Steel Car Co., of Pittsburgh. He remains for two years, and Mr. W. B. Albright, of the Sherwin-Williams Company, for one year. The Club's balance on hand is \$10,489 to begin the new year with.

Xmas Presents

Nothing is more acceptable to a friend than a good book.

Send us the money, your card and his address. We will do the rest.

Give Yourself a Xmas Present

Railway and Locomotive Engineering,	\$2.00
Twentieth Century Locomotives,	- - - 3.00
Locomotive Engine Running and Management,	- - - 2.00
Practical Shop Talks,	.50
Examination Questions for Promotion	- - .75
Locomotive Link Motion,	- - - 1.00
	<hr/> \$9.25

\$9.25 worth of books reduced to \$8.00 on Xmas orders.

Railway and Locomotive Engineering

136 LIBERTY ST., N. Y.

Artificial Limbs

WITH RUBBER HANDS AND FEET

Over fifty years of the most extensive experience with the most satisfactory results of any manufacturer in the world. The Rubber Hand and Foot possess the quality of yielding to every essential angle of the natural, without the use of complicated hinges, joints, and contrivances which annoy and render expensive their daily use.

The accompanying cuts represent a person who lost both legs by a railroad accident, one above the knee and the other two inches below. He is able to walk half a mile in eight minutes, without a cane or assistance, except his artificial limbs with rubber feet. He can perform a day's work without unusual fatigue; can go up and down stairs—in fact, can do any of the ordinary of life without exhibiting his loss.

Arms restore appearance and assist greatly in the performance of labor. From our **New Illustrated Measuring Sheet** Artificial Limbs can be made and shipped to all parts of the world, without the presence of the patient, with guaranteed success. Those who live at a distance and would be inconvenienced by the journey to New York can supply measurements and feel the assurance that they will receive our best attention.



Over 30,000 in use. Eminent surgeons commend the Rubber Foot and Hand. They are endorsed by the United States and many foreign Governments. Received the only Grand Prize awarded to Artificial Limbs at the Paris Exposition, also Highest Awards at the Buffalo Exposition, 1901, and Charleston Exposition, 1902. A treatise, containing 500 pages, with 800 illustrations, sent free; also measurement sheet.

A. A. MARKS, 701 Broadway
NEW YORK CITY

The Sturtevant Portable Forges.

The adaptability of the Sturtevant Portable Forges, to all light forge work, is well known. These forges have stood the test for years not only in this country, but abroad. The sheet metal work is of heavy steel plate, the running gear is heavy, strong and easy of operation. The tuyeres are made extra strong to resist the action of the fire and the fire pan is of a double metal plate with asbestos between to prevent the heat from cracking the main pan or affecting the running gear.

There are seven distinct types represented respectively by the letters A, B, C, D, E, F and G. Types A, B and C are alike except in the means of producing the blast. The blast for the type A forges is provided by an attached blower driven by hand power. The B forges are

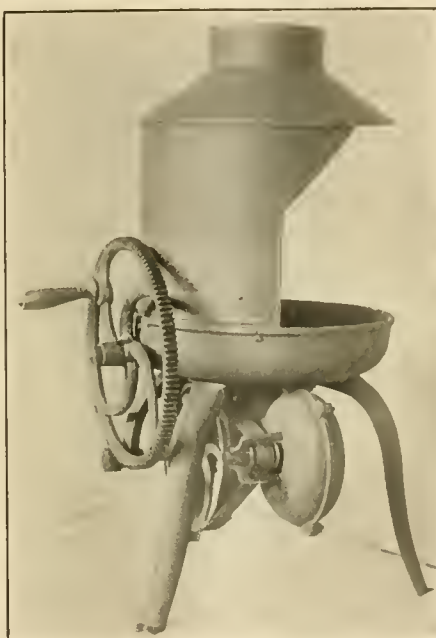

ONE OF THE STURTEVANT PORTABLE FORGES.

arranged for pipe connection and receive blast from an independent blower, which may also supply a number of forges. Forges of the C type are fitted with a blower driven by a pulley on the forge, belt connected to a line shaft or other drive. This one is shown in our illustration.

The A forge is built in five sizes adaptable to all light work, and is extensively used by toolmakers and blacksmiths.

The B type is made in eight sizes, particularly adaptable to mechanical laboratories of technical schools. As before stated, they are similar to the corresponding numbers of the A forges except in the manner of producing the blast.

The C forges are made in four sizes corresponding to forges in the A series. They are fitted with a tight and loose

pulley for belt connection; a continuous blast may be thus provided which can readily be regulated by means of a blast gate underneath the fire pan.

For the lightest forge work, forges D-1, D-2, D-3, E-1, E-2 and E-3 are peculiarly suitable. Sizes D-1, D-2 and D-3 are like A-1, A-2 and A-3, but have shorter legs for bench work, and are arranged for blast connection to an independent blower. The pan tuyere and blower of the E-1, E-2 and E-3 forges are exactly similar to but smaller than those on the A-1, A-2 and A-3 forges, but the hand power attachment is arranged for bench work. With these forges a strong wooden box is furnished sufficiently large to hold a complement of tools, together with the forge itself. This equipment is, therefore, extensively used by repair and set-up men on account of its ease and convenience of transportation. As in the A forges, the three sizes differ only in the hoods.

The F forge is made in three sizes, F-1, F-2 and F-3, exactly like the A-1, A-2 and A-3 forges, except that they have much shorter legs; in fact, they are short enough to give the correct height for operation when the forge is placed on the box.

The G forge is built in two types, with hand or stationary blast; it is extensively used for stationary work on account of its durability. The body is of heavy steel plate, is rigidly braced and provided with wind guard.

All these forges are manufactured by the B. F. Sturtevant Co., of Hyde Park, Mass., who furnish complete forge equipments, including portable and stationary forges, blowers and hand blowers, for producing the blast, exhaust fans for the removal of the smoke, blast and exhaust piping systems, hoods and blast gates.

A Ball Bearing Paper Weight.

An exceedingly neat little paper weight has been got out by the Standard Roller Bearing Company. It does not stand more than 1 3/4 ins. high, but weighs about half a pound, though you would not think it did. It consists in a small circular ball race, 1 5/8 ins. in diameter, made of nickel-plated steel and formed something like the center plate of a car. In this race are placed six steel balls about 5/16 in. diameter, and on top of these stand a ball 1 1/8 ins. in diameter. The top ball is tied to the "center plate" by a screw, which permits the large ball to be turned round on the small ones. This gives a very good practical example of how ball bearings lessen friction and distribute wear. You can put your finger on any one of the balls in the race and stop their movement and then turn, with a noticeable effort, the large one on top; or you can release the race and fairly spin the upper ball round. It

amounts to a sort of miniature object lesson, and you will never get your ideas on friction "balled up" by the use of this clever device. On the contrary, they will smoothly revolve round a pivotal truth. It is as "cute" a paperweight as you ever saw.

Forgot His Prayers.

There was a station master once at Coupar-Angus, on the Caledonian Railway, in Scotland, who was exceedingly devout, but sometimes slipped into profanity when excited. John was usually a sober man, but at the annual St. Andrew's dinner he generally got as mellow as the others.

One morning after the dinner John got home past the small hours and undressed with difficulty. Then he got down on his knees beside the bed and engaged in some incoherent mutterings.

"What's the matter, John," exclaimed his wife, "are ye ill?"

"Na," replied John, "am nae ill, only a canna mind a damned wurd o' ma prayers."

Is the Relief Valve a Failure?

BY J. A. E.

Notwithstanding the assertion made by a master mechanic in a paper read before the St. Louis Railway Club some months ago, that the relief valve was not only worthless in itself but also the great cause of so many ruptured cylinders, ruined valves and leaky steam pipes, it remains for him to produce better evidence to prove his assertion than the test he reports to have taken place on the Missouri & Louisiana Railroad. In all fairness to his audience and readers of his article in the printed proceedings of the club, he should have given a more detailed account of this road, so that those interested might have a better idea of the value of the test.

Official records in the Pocket and Travelers Guide credit this road with eight locomotives, while his statement would lead people to believe that engine 100 used in the test represented the actual number. The Travelers Guide, the official organ of the General Freight and Passenger Agents' Association and a monthly publication always up to date and correct, states plainly that the Missouri & Louisiana has but eighty-one miles of track, is not a continuous line, but is divided into a number of sections, of which the longest contains twenty miles and the shorter ones fifteen miles of road. These parcels can be found distributed throughout several States. The twenty mile section only can boast of a passenger train and that is a "mixed" affair hauling freight also. None of the sections have any regular

trains, and trains run only at such times as the traffic demands.

There is no denying the assertion that the relief valve does not give perfect results, but it must be added that at only very high speed does it fail. As to the resultant damage to the engine claimed from its use in the article referred to above, more convincing evidence than any so far produced will be required to support the charge.

The present writer's attention was called to a case on the Rutland Railroad when that line was operated by the Central of Vermont some years ago. The traveling engineer, Mr. John Donovan, discovered that at high rates of speed with engine drifting, the piston rods and valve stems invariably presented a dead, gummy appearance, and he came to the conclusion that the relief valve was too small, since at slow speeds the parts were always bright. In order to prove his theory he had engine 232 equipped with an additional valve, and the trouble at once disappeared without bad results to the engine in any particular. In view of Mr. Donovan's experience, it looks as if the Wabash master mechanic was as much after the oil record as the relief valve, and it would have been interesting had his paper made reference to a letter posted in one of his round-houses. This letter, which the writer has himself seen and read, is from one of the Wabash engineers, and in it the claim is made that the writer made a most phenomenal record on oil besides saving two gallons for emergencies in one month, since the relief valve had been removed. If the master mechanic had absolute faith in that letter, he should have placed it on record before the club. The object on that road is evidently to secure a better mileage and that much coveted bonus promised by the oil company. Unfortunately the railroads do not get a cash bonus, but receive it in oil. For illustration, if a 100 mile basis is established—and in some cases it is 150 miles—and one engine makes 75 miles and another 125 miles to the pint, the bonus from the latter goes to the former to even up matters; but, if both should make 75 miles only, then the oil company is the loser and makes up the deficit as per contract.

Oil economy has been so thoroughly impressed upon the men with various threats of punishment that the entire force has become demoralized. It has established two classes of men, the timid ones who go to the family butcher and buy tallow, and the dishonest ones who steal oil for a record and a nickel-plated oiler. Both types deceive the management, and the deception is not practiced by engineers only. A case comes to mind of an official who added a barrel of signal oil to the valve oil

H. S. PETERS'
BROTHERHOOD OVERALLS

have gone to almost every part of the World where Overalls are worn and are everywhere conceded to be the BEST. Every point of material, cut, construction and finish is carefully looked after; the only way that superiority can be attained. Every garment is absolutely guaranteed. The Patented, Fleece-lined, Safety Watch Pocket is alone worth a whole suit of any other make.

I'll send sample suits, charges paid, to any place in the World where mail or express goes, where I have no retail agency; sample materials and full particulars for the asking.

UNION MADE
OF COURSE —
B.L.E. 3—H.S. PETERS—B.L.E. 171
DOVER, NEW JERSEY, U. S. A.

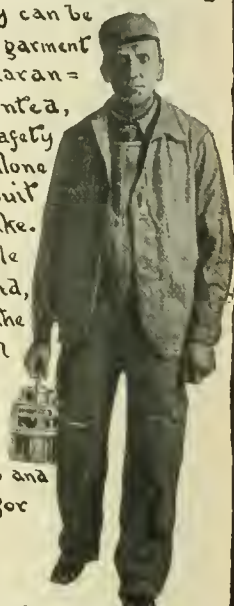

The Twentieth Century Master Mechanic

Won't use solid Mandrels. Cost too much, take up too much room and don't give satisfaction.

Nicholson Expanding Mandrels

Take everything from 1 to 7 inch holes. Take up little room—always ready and you can buy four sets for the cost of one of the solid kind.

Are You Using Them?

Catalogue tells you more about them.

W. H. Nicholson & Co.
Wilkesbarre, Pa.

Besides **ASHTON LOCOMOTIVE STEAM GAGES**



WE MAKE
 Duplex Air Gages
 Gage Testers
 Blow-off Valves
 Chime Steam Whistles
 Pop Valves

ALL OF A SUPERIOR QUALITY

Catalogue L on Application

The Ashton Valve Company, 271 Franklin Street, Boston, Mass.

**Keep
 Your
 Mind
 On
 It**



CRANDALL'S HELIOS AIR PUMP and THROTTLE VALVE

PACKING

Put Up in Sets
 Exact Fit to Rod and Box
 Send Trial Order

The Crandall Pkg. Co.
 123 Liberty Street
 N. Y. CITY
 Chicago Office, 30 La Salle St.

American Locomotive Sander Company

13th & Willow Sts., Philadelphia, Pa.
 Proprietors and Manufacturers,

LEACH, SHERRBURNE, DEAN, HOUSTON, "SHE" and CURTIS **SANDERS**

in order to make a record for his division.

In order to convey a correct idea of the amount of work expected from lubrication; take an 18x24-in. engine with 56-in. drivers, making a mile a minute. In that time at that speed the drivers make 360 revolutions, the piston travels 1,440 feet, and comes in contact with 977,184 sq. ins. of cylinder surface. Six drops per minute—an amount considered amply sufficient by those in authority who preach economy, but never themselves attempt to practically demonstrate what they preach, six drops of oil are supposed to take care of this as well as the valve, which has not been taken into our calculations.

Now here comes a master mechanic who says too much oil is being used and too many engines failing. "Take off the relief valve," he says, "and save oil and engine failures." He might add, "If you doubt

continually designing new and better power have not willfully neglected so important a matter as the relief valve.

Vestibule Door Trap.

The illustrations of this ingenious trap door for vestibule cars are practically self explanatory. When the door is shut the space over the car steps is covered by two steel plates coated with rubber matting. The plates are divided diagonally in the middle and hinged along this line. When the vestibule door is opened the two triangular plates fold together and lie close against the vestibule wall. The device is patented by a resident of Kern City, Cal., and the information and photographs were sent to us by Mr. D. P. Kellogg, master mechanic on the San Joaquin division of the Southern Pacific Company.



VESTIBULE WITH TRAP DOOR DOWN.



VESTIBULE DOOR WITH SELF OPENING TRAP DOOR.

my word, ask the Missouri & Louisiana and my engineer." Since this writer has run regularly assigned engines equipped with relief valves over long and steep mountain grades on the Southern Pacific, Santa Fe and Colorado Midland, in all kinds of weather successfully without any failures occasioned by the relief valve, he is inclined to doubt and discredit charges against the relief valve unless supported by better proof than any so far produced.

If more care and attention were bestowed upon rod cups, lubricators, chokes and oil pipe connections, and there were less hounding of the engineer, the results would be more gratifying. There would be no difficulty in convincing the man "higher up"—unless he had an interest in a coal mine—that insufficient lubrication meant less tonnage and greater coal consumption. Surely our great mechanical minds that are con-

Must Go to the Grave Intact.

The Scotch Highlanders have some peculiar notions about going intact to the grave. In Glasgow some years ago a Highland shunter lost a finger while coupling cars and he caused quite a commotion among other railway men by having a funeral of his finger and burying it in a distant graveyard where his forefathers reposed.

When someone remonstrated with Donald about going to so much trouble for a finger, he replied, "Do you men think that I am coming to Glasgow hunting among the bones of you unregenerate Lowlanders for my finger on the day of judgment?"

The difference between a good man and a good woman is that the former is so odd he's continually lauded, while the latter is merely a matter of course.

Procius, the Engineer.

BY O. L. SHEPARD.

"Lickety-out!" cried the storekeeper from the front door, where he was watching the fast mail whoop through the village.

"Right on the dot," said Wilson, the whittler, consulting a corpulent nickel-plated watch.

"Yas," drawled old Procius, sneeringly, "Right on the dot." And he made great show of noting the exact position of a square of sunlight on the counter.

"Looky here, whiskers," said Wilson, laying aside knife and shingle, "what do you mean?"

"I mean," said Procius, likewise bristling, "that your turnip is just about as reliable as them scales."

The storekeeper chuckled good-naturedly, and the drummer decided that he was honest.

"Leave it to the traveling man," said a lounge. "He has to ketch trains, so his must be standard."

"It is just ten forty-five," declared the drummer, judicially. "But speaking of time and trains suggests modern railroad schedules. It is the improved locomotive which makes them possible. Did you ever stop to think how much engines have changed in the last fifteen or twenty years? They used to be pretty toys, all brasswork and nickel, and with elk-horns on the headlight. Now, they are built on scientific lines—not a sign of lace or frills, but they will pick up fifteen vested cars and reel off sixty an hour as long as the coal and water holds out.

"But," he continued, lighting a cigar, "you don't know anything about engines here in the East. The mammoths reach full maturity only in the Rockies. Why, one day out there, I saw a cyclone blown to pieces by the exhaust from the smoke-stack of one of those hill-climbing juggernauts.

"By the way, there was a curious circumstance in connection with that affair. The engine had a train of empty flats behind her. It seems that the cyclone had passed over the dump of a rich mine a few miles away and had picked up everything but the hole. Well, when the engine burst the cloud-funnel, the gold ore began to rain down, and in five seconds that engine had a trainload of dirt behind her that would assay a hundred dollars to the ton. The engineer pulled it right into the terminal yards and delivered it to the company. He was made superintendent of motive power for that little job."

There was silence in the store. Outside, a rooster crowed, and over at the sawmill they were ripping lazily through endless lengths of hemlock.

"Well," said the aged Procius, "I

don't know. These here new-fangled engines is big all right, and ugly. They run on pretty fast time, with almighty big loads, but—in extraordinary emergency, they can't compare with the old wood-burning machines of my day.

"Years afore you fellers was born, I used to run an old rattletrap over on what is now the Continental. One night, just as I was running her into the round house, the superintendent run up and said to me: 'Peleg, I've got to get over to the Junction in time to ketch the eleven o'clock on the Punk Holler Line. Kin you make it?'

"I looked at my watch, and I had twelve minutes in which to do fifteen miles. 'Climb aboard,' I said.

"It was a wild night—rainy, windy, and dark as sin. I let her out, and we were soon pounding along over the rough track at terrific speed. Just two miles out there was a culvert that I knowed was always dangerous in a heavy rain. It was washed out on an average, three or four times a year. So, when we neared the spot I put an extra spin on her so she would jump the break if there was one. There was a crashing jolt, by which we lost our headlight, and then we were roaring along on the other side.

"'Peleg,' said the superintendent, pulling his head inside, 'It's along here that Benson's gas well ought to show up; and I'm going to discharge that feller at Polk for not keeping them switch-lights burning.'

"'Rain put em out, mebbe,' I said, and signaled the fireman to heave in more wood.

"Well, I thought we were doing some pretty fast time, but it took us eighteen minutes to get to the Junction, and if the eleven o'clock hadn't been late we would have missed it."

The old man paused while he filled and lit his pipe.

"What of it?" asked the drummer, disgusted at the tame ending. "Just you wait, young man, till I'm through. Some subjects will not let a man approach them too hastily. He has to compose himself.

"I was ordered to wait at the Junction till morning. I slept late, and along about 9 A. M. I heard a racket outside my room. A feller peeked over the transom, and heads began to appear at the window. 'That's him,' one said. 'He's waking up, and not a scratch on him,' said another. Well, when I got outside, there was a crowd waiting for me. 'Three cheers for the brave engineer' a galoot shouted, and they gave them.

"To make a long story short, the fellers said that the old machine, instead of taking the track after jumping the

THIS



BOOK

on pumping, air-compressing and condensing machinery is

Given Away

by each of the following companies:

Henry R. Worthington
Laidlaw-Du-n-Gordon-Co.
Blake-Knowles Steam Pump Works
Deane Steam Pump Works
Clayton Air Compressor Works

114-118 Liberty Street, New York

Patents.

GEO. P. WHITTLESEY
MCGILL BUILDING WASHINGTON, D. C.
Terms Reasonable. Pamphlet Sent

The Union Switch & Signal Co.

Consulting and Manufacturing
Signal Engineers.

GENERAL OFFICES AND WORKS AT
SWISSVALE, PA.

DISTRICT OFFICES:

New York: Central Building, 143
Liberty Street.

Chicago: 1536 Monadnock Building.
St. Louis: Terminal Station.

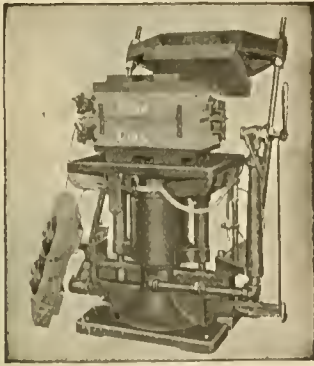

All Kinds of Molding Machines

- Machines that ram
- Machines that draw patterns
- Machines that do both
- Machines that strip patterns
- Machines that vibrate patterns
- Machines that do both
- Machines for jar ramming deep molds
- Power squeezers which do the work when you press a pop valve
- Machines which use compressed air and machines which don't

THE TABOR MFG. CO.

18th and Hamilton Sts.
PHILA., PA.
30-32 South Canal Street
CHICAGO, ILL.
84 Mason Building
BOSTON, MASS.
49 Deansgate
MANCHESTER, ENG.
Fenwick Freres
PARIS
Schuchardt & Schutte
BERLIN

culvert, had struck out across lots, through fields and woods about eight miles, and had taken the rails again just before we reached the Junction.

"Well, I wouldn't believe it till I went out to see for myself. Sure enough, there was a clean swath cut right through the territory. Trees, fences, barns—whatever lay in our path, was tossed aside, and along the ground lay the nicest, smoothest dirt track you ever saw. It was scraped level by our ash pan."

"But," said the drummer, "I know that territory. How did you cross the river?"

"The river? Why we crossed on a chain cable that has been stretched across in war times to keep the Rebel gun-boats from coming up to the town."

"Enough!" sighed the drummer, ris-

Pond 36-Inch Lathe.

The annexed engraving illustrates the 36 in. lathe, made in the Pond Shops of the Niles Bement Pond Company. It swings 37 ins. over the bed and 30½ ins. over the carriage. With 12 ft. bed, will turn 5 ft. between centers. The spindles are of hammered steel. The live spindle is mounted in bronze bearings. The cone has five wide belt steps of large diameter. It is mounted on the face-plate spindle, is back geared and geared into an internal gear on the face plate, giving fifteen changes of speed. The sliding head has a set-over for taper turning and is easily moved by gearing engaging the steel feed rack. The bed is sufficiently wide to support the tool slide without the latter overhanging its front when turning the largest diameters. The carriage has

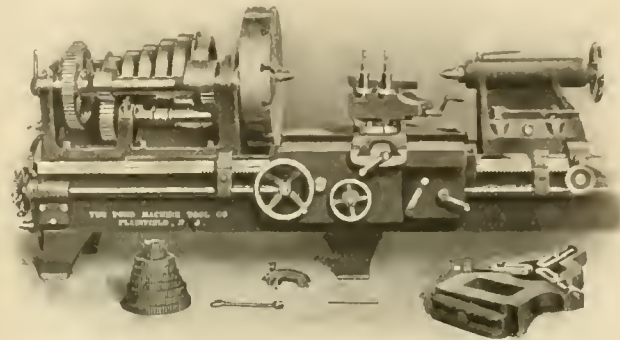

36-INCH LATHE. NILES-BEMENT-POND CO.

ing and brushing the cigar ashes from his vest.

"Nope," said Precious, "There's more. That engine cut through on a line over which the company had been trying to get the right of way for years. There was a freak law in that state then which meant, in effect, that a railroad company should hold right of way, options, and everything, wherever it could run an engine without interference. I got \$10,000 for that night's work."

"Anything more?" asked the drummer, wearily.

"Yes. A feller owned a haunted house down on the sand road which he couldn't give away. We knocked it to smithereens that night, and he got \$3,000 damages and sent me \$500 out of gratitude. In fact, I've been getting checks, off and on, ever since from people who got damages for some worthless thing being killed, maimed, or smashed. Why, one feller sent me fifty cents for killing his mother-in-law."

"The cider on me!" murmured the drummer, waving weakly to the chubby storekeeper.

long bearings upon wide tracks, is gibbed to outside edges of the bed, and can be clamped when cross-feeding. It is provided with a tool slide having compound and swiveling movements; also with screw-cutting attachment and automatic friction, longitudinal and cross feeds. If either of the feeds or screw-cutting attachment is in use it locks out all others. The direction of the feeds can be changed at the carriage. Screw cutting attachment and feeds are connected to the live spindle by three gears and a sliding key, giving three changes without changing gears. The carriage gearing is driven by a spline in the steel lead screw. The thread of the steel lead screw is used only for screw cutting. The gear engaging feed rack can be disengaged when cutting screws, thus preventing uneven motion caused by revolution of the feed gearing.

The highest type of philanthropy is that which springs from the feeling of brotherhood, and which, therefore, rests on the self-respecting, healthy basis of mutual obligations and common effort.—*Theo. Roosevelt.*

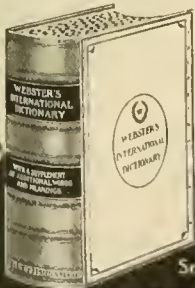

It is Up to Date and Reliable

WEBSTER'S INTERNATIONAL DICTIONARY

Includes in the New Edition
25,000 NEW WORDS, Etc.
New Gazetteer of the World
New Biographical Dictionary
Edited by W. T. HARRIS, Ph.D., LL.D.,
U. S. Commissioner of Education.
2380 Quarto Pages. 5000 Illustrations.
New Plates. Rich Bindings.

Also Webster's Collegiate Dictionary with 1100 pages, 1100 Illustrations. Size: 7x10x2½ in.

A Special Thin Paper Edition De Luxe. Printed from same plates as regular edition. It has limp covers and round corners. Size: 5¼x8 x1½.

FREE, "A Test in Pronunciation," instructive and entertaining. Also illustrated pamphlets.

G. & C. MERRIAM CO.
Publishers, Springfield, Mass.

A New Style Floorer.

The new machine here shown has all the advantages and conveniences which have made the older ones so useful and satisfactory in the past, and over these there is an array of still newer features fully covered by letters patent, that enable the machine now to be one of the finest ever built, and one possessing to the fullest possible extent the three requisites that make a machine strictly first class and up to date in every respect. These are: Economy of time, labor and attention in making the various adjustments; efficiency in the high-class of work it will turn out, and these two giving a large output, thus endowing the machine with the trinity of points which every lumberman and woodworker looks for in a modern machine. It is designed to enable its user to hold the pace in face of the most strenuous competition.

The machine was patented March 20, 1900; November 12, 1901, and May 27, 1902, and is especially recommended to large makers of flooring, ceiling, casing, siding and other work of that char-

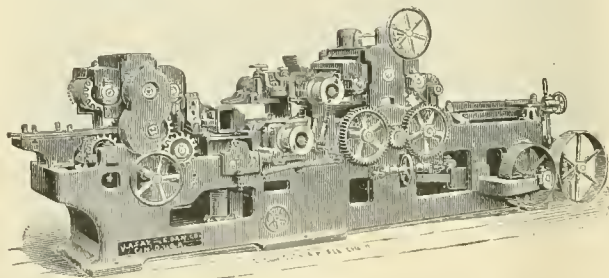

No. 106. DOUBLE CYLINDER "LIGHTNING" FLOORER.

acter. Its capacity for turning out much work will be better understood by the word "Lightning," which means that the output depends more on the ability of the operators, and is only limited by their quickness. It will work the four sides of material 15 ins. wide and 6 ins. thick, matching as narrow as $1\frac{1}{2}$ ins.

Every working part of the machine is interchangeable, and all so compactly and strongly built together as to make the machine very powerful and substantial, and capable of standing up to full pressure without strain or vibration. It will work twisted or warped lumber with facility. The machine is also made with the lower cylinder cutting first, being then called No. 107, or with a third cylinder placed below the upper, it is called No. 108. In this last the upper cylinder is placed between the two lower ones, and the stock is worked face down, and is given an extra fine finish at a very high speed. This is an advantage readily appreciated by makers of hardwood flooring.

This machine has too many points to be adequately enlarged upon here, and

to cite some would be to leave out others equally important, and yet it is necessary to know all, to thoroughly understand its merits. We would advise any of our readers who would like further information about this tool to drop a postal card to the makers for full particulars. Also ask for their new illustrated catalogue of woodworking machinery, which shows many other first class tools they build for lumbermen.

Address J. A. Fay & Egan Co., No. 445 W. Front street, Cincinnati, Ohio.

Master Blacksmiths' Association Proceedings.

The report of the proceedings of the twelfth annual convention of the National Railroad Master Blacksmiths' Association has just been issued. It is a neatly printed book of standard railroad size, and contains 230 pages. There were about ten reports and papers presented and they were most practical in character. Some of them were entitled Best Material and Method of Forging Motion Work, Rocker Shafts, Valve Yokes, Eccentric Jaws, etc.; Method of Test-

ing Material and Selecting Same for Use Intended; Frame Making. Best Material and Method of Preparing Same for Scrap; Repairing Locomotive Frame; Ideal Blacksmith Shop; Spring Making, Repairing, Tempering, etc., and Tool Steel Forging and Tempering, including the High Speed Variety. The president of the association is Mr. T. F. Keane, Hilburn, N. Y., and Mr. A. L. Woodworth, of Lima, Ohio, is the secretary. The proceedings can be had by applying to either of these gentlemen.

Many of our readers will be glad to learn that the railway, steamship and mill supply business carried on for a quarter of a century by the late H. A. Rogers, at 19 John street, New York, will be continued at the old stand by the H. A. Rogers Company. We bespeak for the new concern the same liberal patronage that the painstaking efforts and conscientious fulfilment of obligations, which characterized the transactions of the late Mr. Rogers secured for him and which he so fully merited.



Hurry Up with the
GILMAN BROWN
EMERGENCY KNUCKLE
 The Trainman's Friend



RAILWAY APPLIANCES COMPANY
 Succeeding Q & C Co.
 General Offices: Old Colony Bldg.
 New York Office: 114 Liberty St.

THE ROBERT W. HUNT & CO.
 Bureau of Inspection, Tests and Consultation,
 1137 THE ROOKERY, CHICAGO.
 66 Broadway, New York. Park Building, Pittsburgh.
 31 Norfolk House, London, Eng.
 Inspection of Steel Rails, Splice Bars, Railroad Cars,
 Wheels, Axles, etc. CHEMICAL LABORATORY Analysis
 of Ores, Iron, Steel, Oils, Water, etc. PHYSICAL LABO-
 RATORY—Test of Metals, Drop and Pulling Test of Com-
 pressors, Draw Bars, etc.
 Efficiency Tests of Rollers, Engines and Locomotives.

JUST PUBLISHED — THE — LOCOMOTIVE UP TO DATE

The greatest accumulation of new and practical matter ever published treating upon the construction and management of modern locomotives, both

SIMPLE AND COMPOUND

By CHAS. McSHANE
 Author of "One Thousand Pointers for Machinists and Engineers."
 Special Exhaustive Articles were prepared for this new book by the
Baldwin Locomotive Works
Rogers Locomotive Company
Schenectady Locomotive Works
Pittsburg Loco. and Car Works
Brooks Locomotive Works
Dickson Locomotive Works
Cooke Loco. and Machine Co.
Richmond Loco. and Machine Co.
 With contributions from more than one hundred prominent railway officials and inventors of special railway appliances.
 736 Pages. 6x9 inches 380 Illustrations
 An Absolute Authority on All Subjects relating to the Locomotive
Bound in Fine Cloth, \$2.50

ONE THOUSAND POINTERS — FOR — MACHINISTS and ENGINEERS

By CHAS. McSHANE
 (Practical Machinist)
 Assisted by CLINTON B. CONGER, Air Brake Expert; J. P. HINE, Mem. Div. 37, B. of L. E.; J. G. A. MEYER, Mechanical Engineer; W. M. F. GOSS, Mechanical Engineer; JNO. C. WHITE, Indicator Expert. The only complete work on the locomotive combining both theory and practice. 342 pages, 187 illustrations.
BOUND IN FINE CLOTH, \$1.50
 The only book ever endorsed by the International Association of Machinists. Agents wanted everywhere; write for terms commissions and club rates. Will be sent prepaid to any address upon receipt of price.
GRIFFIN & WINTERS, Pub.
 171 La Salle St., CHICAGO, ILL., U. S. A.

The BARRETT GEARED RATCHET CAR JACKS



No. 29, 25 Tons Capacity.
No. 30, 35 Tons Capacity.
**IMPROVED QUICK
ACTING JACKS**

for the rapid handling of Empty or Loaded Cars and Coaches and for Locomotives.
Easy to Operate, and they have no intricate parts or complicated features. Have all the simplicity of the ordinary Lever Jack, and are more reliable and better adapted to car work than either Hydraulic or Screw Jacks.

Send for Special Bulletin "L"

MADE ONLY BY

THE DUFF MANUFACTURING CO.

Works: Allegheny, Pa. PITTSBURG, PA.
FAIRBANKS, MORSE & Co., Chicago,
Agents for Railroad Dept.

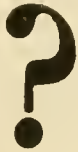

Did it ever occur to you that the reason for the vast passenger business done by the Lake Shore is due to the excellent accommodations which it furnishes?

Unexcelled for travel between Chicago, Toledo, Cleveland, Buffalo, New York, Boston and all points east and west.

Insist on the agent furnishing you a ticket reading over Lake Shore.

You will be pleased with your journey.

Ask for copy of "Book of Trains."

A. J. SMITH, G. P. and T. A., Cleveland, O.

Flexible Spout

Vertically in straight line. Also laterally. The latest Improvement to

Poage Water Columns

American Valve and Meter Company

CINCINNATI, OHIO.

SEND FOR CATALOGUE

Otto Gas Engine Catalogue.

The Otto gas engine works, of Chicago, have issued a pamphlet on the water stations of the Chicago & Alton. This road, "with its 908 miles," so says the article, "probably has a larger number of gasoline-engine pumping plants in operation than any other road in the country." There is one gasoline station to each 33.6 miles. A very material saving is shown in 1903 as against 1900, when there were only two small gasoline stations on the road. The statement shows a saving of 2.3 cents per thousand gallons of water pumped. In November of 1903 there was very much more water pumped than in November, 1900; in fact, the former month shows over 20,000,000 gallons in excess, but the saving effected without reference to the amount pumped was \$527 for the month. All the Alton pumping stations are of the Otto type. The pump is placed in a frost-proof pit in a circular house of 14 ft. diameter. Everything is neatly and compactly arranged. If any further information on this subject is required it can be had direct from the Otto Gas Engine Works, 360 Dearborn street, Chicago.

Fire Test of Westinghouse Generators.

Three Westinghouse 62½ kilowatt engine type generators, which have been in service in the basement of the New England Building, Cleveland, Ohio, have recently been subjected to a test which shows up Westinghouse construction in a very good light. A fire occurred in the basement where the generators were installed, and completely burned away the insulation on the outside of the field coils; the fire department played upon these machines with six lines of hose for one hour. Within one hour from the time the water was turned off the machines, one of them was in operation and carrying its full rated load. The second machine was put in operation later, and carried its full rate load, and at the present time two of these machines are operating under the load normally carried by all three of them.

The fireproof insulation of the field coils withstood the fire perfectly even, though the outer protecting coverings were entirely consumed, and the heat was so intense as to burn and blister the finish on the frames. Electrical machinery as usually constructed is scarcely expected to stand a fire and water test, but it appears that such a guarantee might have been made on these generators.

The J. A. Fay & Egan Company, of Cincinnati, the great manufacturers of wood working machinery, have made many important improvements in wood working machines; for instance, they have been allowed 200 new patents in the last three years alone. It is re-



Brass, 1½ in., \$6.00 net

HOMESTEAD

STRAIGHTWAY
LOCOMOTIVE

Blow-off Cocks

IRON BODY. BRASS PLUG
Turns easily, but when closed
valve is forced tightly to seat

OFFICE

PITTSBURGH, PA., U.S.A.

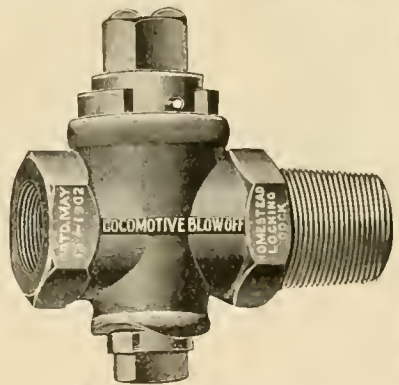

Iron Body, Brass Plug, 1½ in., \$4.00 net

ported that they have found several firms infringing their new patents, particularly on band rip saws, band resaws, gang dovetail machines, planers, etc., and are now getting evidence and preparing papers for a few law suits, which will soon be launched.

We have received catalogue F, of the Reed Manufacturing Company, of Erie, Pa. It is well illustrated and shows the fine line of small tools made by the company, such as stocks with solid dies and with adjustable dies, pipe vises, combination vises, pipe cutters, pipe cutter wheels, pipe taps, pipe reamers, combination drill and tap, combination pliers,

Why Should I?

Ask yourself the question, "Why should I read the SCIENTIFIC AMERICAN?" Because you cannot keep abreast with the world's progress without it. To keep in touch with the great, throbbing life of to-day—industrial and commercial—you must be familiar with the things that are published *only* in the SCIENTIFIC AMERICAN. The world's progress in science, mechanics, engineering, industry, the latest inventions and discoveries; wireless telegraphy, automobiles, naval progress—in fact everything new to the world appears from week to week in the

Scientific American

Its sharp, accurate, popular articles open the mysteries of science; show how men have made dreams realities; mirror the ingenuity and inventive genius of the American workman; give an outlook on the world of the unknown; and bring the reader in touch with the great inventors of the age. The subscription price is \$3.00 a year. In addition we offer to *new* subscribers, for a short time only

Scientific American Reference Book FREE With One Year's Subscription.

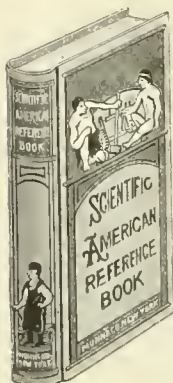

This Reference Book contains 50,000 facts—accurate, down-to-date, complete. Condensed from great encyclopedias and over a ton of government reports, it is the most reliable and exhaustive book ever published. Anything you want to know, on any subject in any part of the world, can be referred to instantly. Handsomely bound, it will not be sold for less than \$1.50 a copy. Subscribe now to the SCIENTIFIC AMERICAN and get the Reference Book free, and in addition 52 numbers of the brightest, most interesting paper published. Sample sheets of the Reference Book and a copy of the SCIENTIFIC AMERICAN sent on request to any address. *Write to-day.* Address Subscription Departments. Remit \$3.00.

MUNN & CO., Publishers,
355 Broadway, N. Y.

CONTENTS.

	PAGE.
Air Brake Department.....	555
*Bridge, the Laurier.....	560
Cars:—	
*Hospital, on the Long Island Railroad.....	562
*Parlor Cars for Boston & Albany.....	537
Safety Valves for Tank.....	558
*Used for Coaling Canal Boats.....	543
Ventilation of Passenger.....	549
Correspondence, General.....	541
Correspondence, School.....	451
*Compound, the Richmond.....	561
Editorial:—	
Eye Doctor, Sensational Voice of.....	547
Fireman, the Modern.....	547
Railway Antiquities, Our Collection of.....	548
Rapid Transit in New York City.....	562
Locomotive:—	
*Electric for N. Y. C.....	531
*4-6-2 for Central So. African.....	535
*2-8-0 for Canadian Pacific Railway.....	545
*2-6-0 for N. Y., N. H. & H. (Bal. Com.).....	559
Handling Leaky.....	543
Petrol.....	536
*M. C. B. Drop Testing Machine.....	539
Shoes and Wedges, Laying Off.....	543
Shop Appliances:—	
*Paint Shop Scaffolding.....	540

etc., etc. At the back of the catalogue there are four pages of useful information such as mensuration rules, weights and measures, hydrostatic tables and the melting point of various metals. Write to the makers of Reed tools for a copy and they will be happy to send you the catalogue.

"Lest You Forget," is the title of a neat little catalogue on power punching and shearing machinery got out by the Long & Allstatter Company, of Hamilton, Ohio. The half-tones used in this little publication are exceedingly clear, and under or beside each is a description of the machine. Many of the tools shown are electrically driven, and with motor placed conveniently and so disposed as not to take up much room. All the tools are of the latest design and are made to stand up to the exacting requirements of modern railroad shop practice. Write to the company for one of these catalogues if you are interested, and do it soon, "lest you forget."

A day or two after the speed tests of the New York Central electric locomotive were made by the General Electric Company, reports were widely circulated that the Delaware, Lackawanna & Western people were about to introduce electric operation for their whole suburban passenger business, which is the greatest in the United States. When President Truesdale was interviewed on the subject he said they had no intention whatever of changing their motive power.

The Derry-Collard Company, of New York, have published what they call an "encyclopedic X-Ray engraving of a modern battleship," which is similar to our transparencies of locomotives. The engraving is splendidly done and shows over 450 parts very distinctly, giving all their names. The chart is in itself an excellent school course of marine engineering and will be of great value to people who are any way connected with steamships. It is sold at the ridiculously low price of 50 cents a copy.

The Chicago Great Western has built a very large round house at Oelwein, where the principal repair shop of the company is located. The new engine house is built of brick and stone, and is thoroughly modern in its appointments. Ample store rooms for material and oil have been provided. The round house is regarded as the biggest of its kind to be found anywhere in the Middle West.

- *Bronze Furnace, Portable.....550
- *Shop, Modernizing an Ancient.....541
- *Ideal Blacksmith's.....534
- *Signals and Signaling, by Geo. S. Hodgins...567
- *Valve Inside Admission Piston.....565
- *Valve Motion, Walschaert.....534

GREATEST AIR BRAKE BOOK EVER PUBLISHED

Modern Air Brake Practice

ITS USE AND ABUSE

By FRANK H. DUKESMITH

Patentee of the Dukesmith Air-Brake Release Signal.

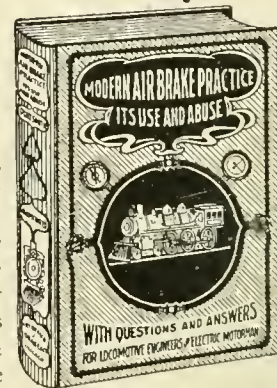

With Questions and Answers for Locomotive Engineers and Electric Motor-men.

300 pages, fully illustrated, fully indexed and cross indexed.

Price, \$1.50

TESTIMONIALS—PRESS REVIEWS

THE WESTINGHOUSE AIR BRAKE CO.

Pittsburg, Pa., Jan. 22, 1904.

F. H. Dukesmith,

Dear Sir: I desire to congratulate you on the thorough manner in which you have described the Westinghouse Air Brake in your new book of instruction, "Modern Air Brake Practice, Its Use and Abuse," as your style of writing is so remarkably clear that any railroad man can easily comprehend it. Yours very truly,

WALTER V. TURNER.

"Modern Air Brake Practice, Its Use and Abuse," by F. H. Dukesmith. We consider it the simplest and most comprehensive document ever published on this subject, and believe it will be recognized as a standard authority on this question.—Switchmen's Journal, June, '04.

Bellevue, O., Nov. 1, '04.

Mr. F. H. Dukesmith,

Dear Sir: After having read your book, "Modern Air Brake Practice," I take pleasure in recommending it as the most complete I have ever read, taking the subject as you do in three sections—Section 1, explaining the different parts of equipment and their duties; Section 2, explaining their various defects arising from the use and abuse of equipment, and their remedies; Section 3, devoted to the philosophy of air brake handling—in this way making the subject concise and in a manner in which even a beginner may receive a thorough knowledge. Yours very truly,

R. HILLHOUSE,
Foreman N. Y. C. & St. L. R. R.

We have no hesitation in recommending this valuable work to any of our readers who may be interested in this important branch.—Railway Carmen's Journal, June, '04.

A useful book for railway men and mechanics.—The Canadian Engineer, June, '04.

Sent prepaid to any address in the world on receipt of price, \$1.50. We guarantee to return your money if the book is not as represented. Catalogue free. Address

FREDERICK J. DRAKE & CO.

Publishers of Self-Educational Books for Mechanics

219 EAST MADISON ST., CHICAGO

Computers

Train Resistance Computer and Locomotive Tractive-Power Computer

Each Computer is in a neat folding, leather-covered case. One side gives formula and directions for use. The other side has a graduated circle upon which turns a graduated card disc.

Can be Adjusted in a Moment to Give Result Without Calculation

THIS OFFICE

Price, \$1.00 Each









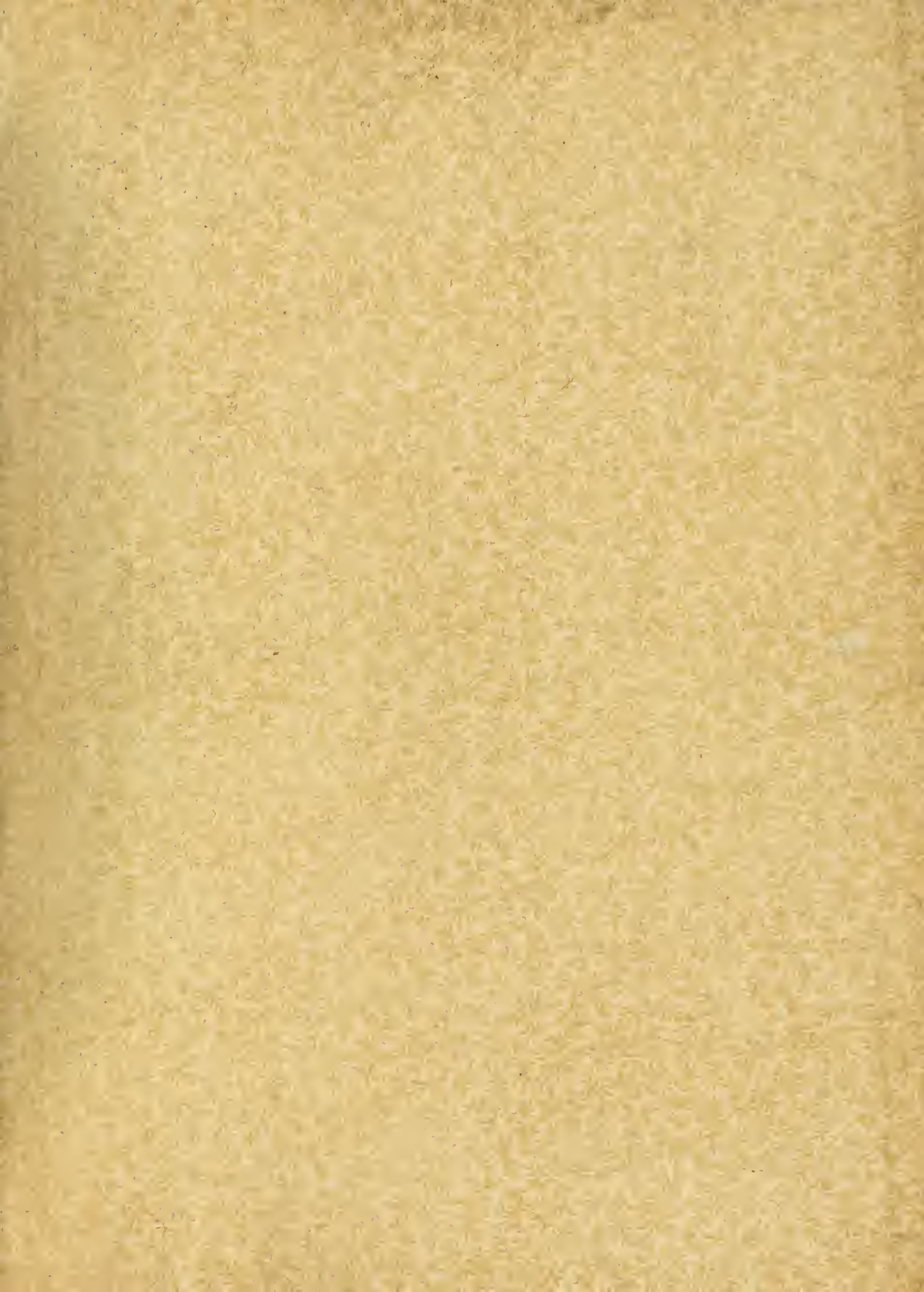

CARNEGIE LIBRARY OF PITTSBURGH



3 1812 04298 5490

